

SHOWER & TUB/SHOWER INSTALLATION

Clarion
EVERYDAY LUXURY

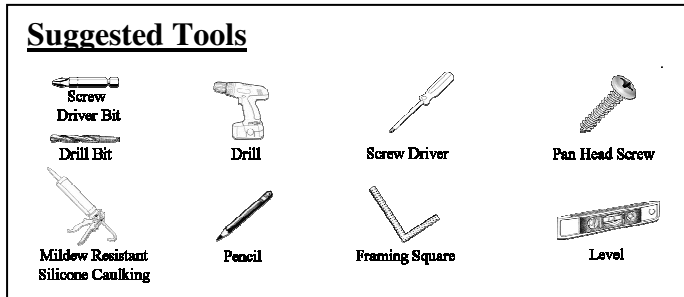

Please consult all local and state building codes and read the entire installation instructions prior to beginning the installation of this unit to ensure that the installation is performed correctly.

Clarion Bathware's tub/showers are to be stored in a dry area prior to installation to prevent moisture from attacking the reinforcement material which could cause warpage to the unit.

WARNING: FAILURE TO FOLLOW THESE INSTALLATION INSTRUCTIONS COULD VOID THIS PRODUCTS WARRANTY. A licensed plumber is required to install or supervise the installation of these units. These units are thoroughly tested in the plant to ensure their ability to drain water properly. Failure to follow these handling and installation instructions may cause improper drainage, thus voiding the unit's warranty.

Pocket dimensions and drain location can be obtained from your retailer or at www.clarionbathware.com/search (1) enter model number of the unit then click search, (2) select the product picture, (3) under downloads and maintenance select the product cut sheet (pdf).

Clarion Bathware's products are designed to be self-supporting. However, in cases where the occupant of the home has excessive weight, we recommend that the unit be installed on a bedding material of cement or casting plaster. Use of a bedding material is required if the unit is being installed in a high use facility. (ie: dormitory, locker room, nursing home, motel, hotel, etc.) The use of a bedding material however is optional and done at the discretion of the customer. If a bedding material is used, be sure to place a moisture barrier, such as plastic, between the bedding compound and the unit

Step #1

Figure 1 Framing the Pocket

Frame a square and plumb pocket to dimension of the unit. If the unit being installed has a whirlpool option installed, future access to the pump and parts should be considered when installing. It is advised, and is required by many local and state building codes that an access area be incorporated into the framing for a whirlpooled tub/shower

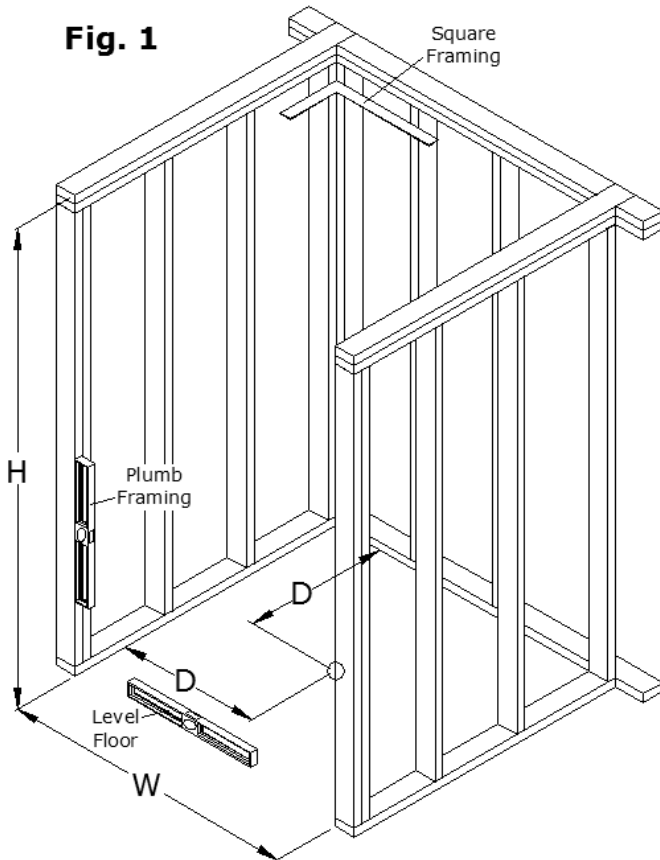

* H= Height of framing pocket should be at least the height of unit that is being installed.

* W= Width of framing pocket should be no wider than the width of the unit being installed. Shims may be required.

* D= Dimensions provided on the cutsheet of the unit which show the drain location.

NOTE: Accommodations should be made in the pocket dimensions for any accessories attached to the unit.

Step #2

Figure 2 Setting the Unit

Plumbing fixture can be installed prior to setting the unit into the framing pocket or after.

Install the drain and make sure that it is sealed properly and not leaking. Set the unit into the framed pocket. Check that the drain is not resting on anything which can force the unit floor upwards. Plumb and level the unit. The legs of the unit must contact the floor for proper support. Shims may be placed under the legs to maintain solid contact where needed.

Use appropriate size shims to fill any gaps between the flange and the framing members. Once the unit is plumb and level and any gaps are shimmed, secure the vertical flanges every 6" or as necessary and the horizontal flanges wherever they come into contact with the studding with galvanized nails or screws. Pre-drilling for the fasteners may be desired to reduce the risk of damaging the unit.

Fig. 2

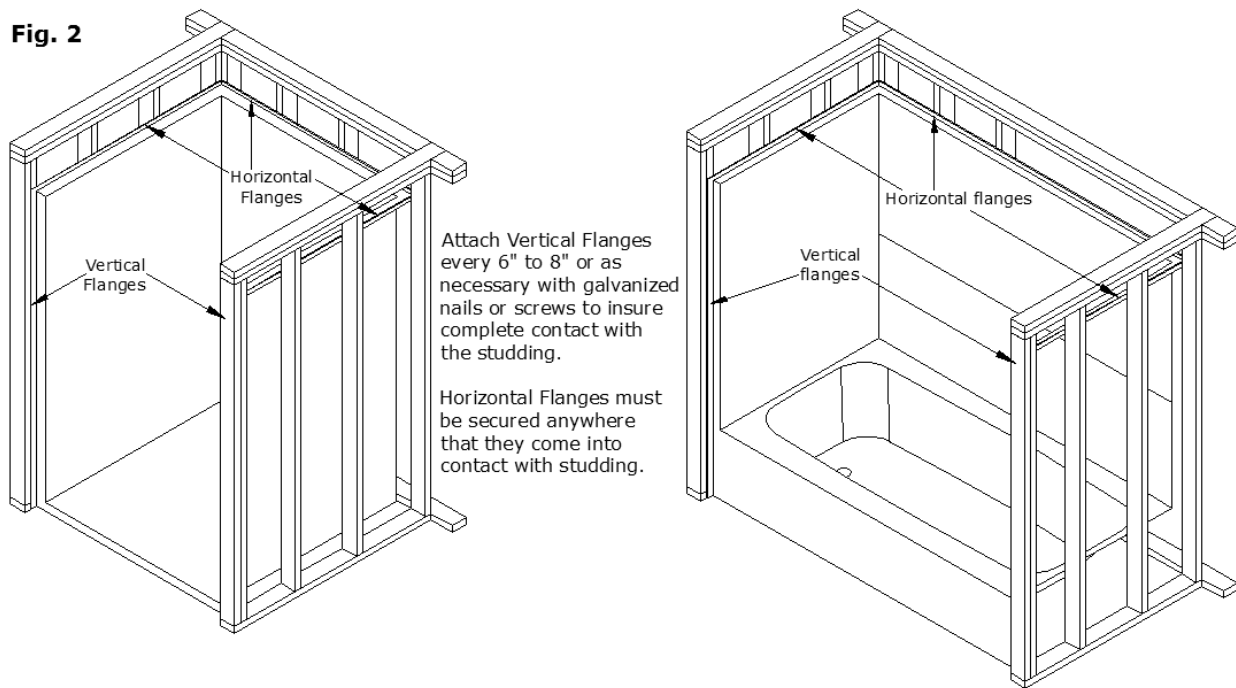

(In an application where the unit is installed over wall board, the Clarion Bathware E-Z Wall Trim Kit (Fig 3) will help you finish your installation quick and easy. For best results your fasteners will need to be flush with the nailing flange. Clarion Bathware recommends centering and counter sinking a corrosion resistance fastener on the nailing flange. Raised fasteners will result in a problematic finishing process of the trim kit.)

E-Z Wall Trim (Fig 3): Clarion Bathware's offers E-Z Wall Trim for a quick and easy installation to finish off the wall nailing flange when the unit is installed over wall board. E-Z Wall Trim is available in pieces or in pre-mitered kits. Contact your supplier or call (800) 576-9228 for more details.

E-Z Wall Trim Application

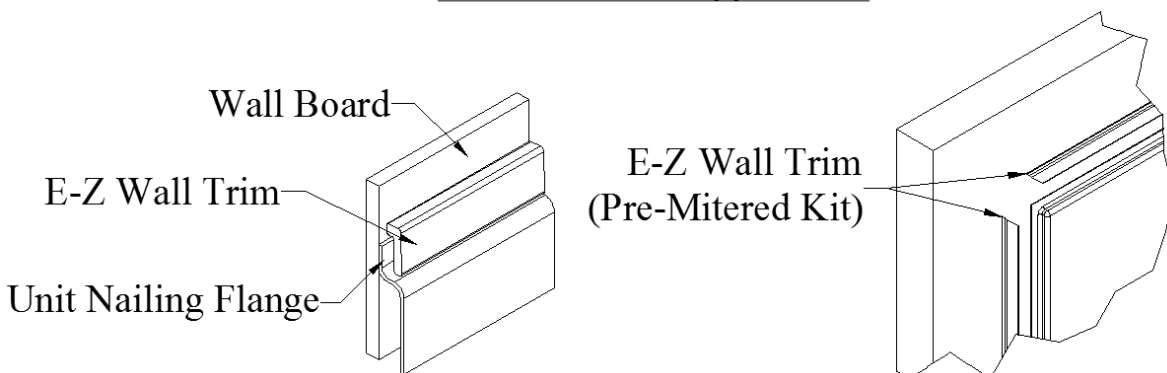

Fig 3

Final Notes:

You can finish off your new unit with a variety of materials which are accepted by local building codes. Some ideas are tile, drywall caulking, drywall mud, plaster, wood or plastic trim.

Clean your new tub with a liquid detergent and warm water.

Do not use any abrasive cleaners such as scouring powder or liquid abrasive cleaners.

IF A BEDDING MATERIAL IS USED UNDER A UNIT; CEMENT SLURRY, THIN MORTAR MIX, PLASTER OF PARIS, OR A COMPARABLE FLOOR FILLING COMPOUND THAT IS NOT WATER SOLUBLE ARE PROPER BEDDING COMPOUNDS. WATER SOLUBLE MATERIALS, FOAM AND OTHER EXPANDING MATERIALS ARE NEVER TO BE USED AS A BEDDING COMPOUND.

NOTE: ANY BATHING WELL CAN BE WHIRLPOOLED. IT IS IMPORTANT TO DETERMINE WHERE YOU WILL HAVE ACCESS TO THE PUMP IF IT NEEDS SERVICED IN THE FUTURE. ACCESS TO THE WHIRLPOOL PUMP AND PARTS SHOULD BE CONSIDERED PRIOR TO PURCHASING AND/OR INSTALLING A WHIRLPOOLED UNIT. AN ACCESS AREA ON WHIRLPOOLS IS REQUIRED BY MANY BUILDING CODES. ALL WHIRLPOOLS MUST BE WATER TESTED PRIOR TO BEING INSTALLED. FAILURE TO WATER TEST CAN VOID THE WARRANTY.

IF YOU HAVE ANY QUESTIONS REGARDING INSTALLATION OF YOUR CLARION BATHWARE PRODUCT, PLEASE CALL OUR CUSTOMER SERVICE DEPARTMENT AT 1 (800) 576-9228 EXT. #818 OR BY E-MAIL AT CUSTOMERSERVICE@CLARIONBATHWARE.COM

JOB SITE INSTALLATION OF OWNER SUPPLIED ACCESSORIES

All Clarion Bathware units purchased with supplied grab bars are custom reinforced at the factory to accommodate the mounting of said bars.

Any grab bars installed on a Clarion Bathware unit at the job site must have proper reinforcement (wood support and backing plates) at all mounting areas and should comply with ANSI A117.1, Uniform Federal Accessibility Standards (UFAS) and ASTM F446 specifications for grab bars in the bathing area.

Job-site installation of third party supplied grab bars is entirely at the risk and full responsibility of the owner. Any damage to Clarion Bathware units or the property during or after grab bar installation, or any injuries due to improper installation remain the sole responsibility of said owner and cannot be attributed to Clarion Bathware, Inc.

*****WE SUGGEST THAT THE CUSTOMER AVOIDS USING A BATH MAT IN THE UNIT, AS IT COULD CAUSE WATER STAINS OR BLISTERING TO THE FINISH SURFACE OF THE UNIT.**

CLARION BATHWARE PRODUCTS ARE CERTIFIED TO MEET NAHB STANDARDS, HUD/FHA, BOCA, HUD UM-73A, ANSI Z124.1 AND ANSI Z124.2. FOR DETAILS, REQUEST NAHB RESEARCH CENTER CONFIRMATION.

EVERYDAY LUXURY

44 Amsler Avenue Shippenville, PA 16254
(814) 226-5374 (800) 576-9228
Customer Service: Ext. #818
Fax: (814) 226-0730
www.clarionbathware.com

**PLEASE READ YOUR WARRANTY VERY CAREFULLY
WARRANTY EFFECTIVE MARCH 1, 2016**



Clarion Bathware offers the following limited warranties against defects in material and workmanship. These warranties apply only to the original owner/end-user and are non-transferrable.

Residential use: Merchandise is guaranteed for a period of six (6) years from the date of initial purchase against defects in material and workmanship.

Commercial use: Merchandise is guaranteed for a period of six (6) years from the date of initial purchase against defects in material and workmanship.

Component/Accessories: Merchandise supplied by Clarion Bathware is guaranteed for a period of one (1) year from the date of initial purchase against defects in material and workmanship.

All claims must include proof of purchase. If within the warranty period any such product shall prove **to be** defective of material defects, manufacturing defects, labor defects, it shall be repaired or replaced (with a product of equal value) excluding removal and installation at the manufacturer's option.

Shipping Damages: All units must be carefully inspected upon delivery. Any damage must be reported on the receipt or freight slip at that time.

When applying the warranty, adequate time must be permitted to schedule and complete the work. Inspections and work will be scheduled and completed by an authorized representative of Clarion Bathware.

Clarion Bathware will not be responsible for any claims related to failures, damages, delays or excessive costs incurred that could have been discovered, avoided or repaired with proper inspection and testing prior to or during installation.

EXCLUSIONS:

1. This warranty shall not apply to incorrect operating procedures, breakage or damages caused by normal wear and tear, improper storage, fault, carelessness, negligence, abuse, misuse, use other than intended (non-bathing), misapplication, improper maintenance, alteration, or modification of the unit by or for the buyer, as well as chemical or natural corrosion, fire, act of god, or any other casualty.
2. The original owner/end-user covered by the present warranty is entirely responsible for its proper installation and for all plumbing and electrical connections. Clarion Bathware neither installs nor supervises or contracts for the installation and consequently cannot be held responsible for it.
3. This warranty does not apply to units or equipment not installed and connected in accordance with manufacturer's instructions and in conformity with all local, state, codes for such installations.
4. CLARION BATHWARE IS NOT LIABLE FOR PERSONAL INJURY OR DEATH TO ANY PERSON, INCIDENTAL OR CONSEQUENTIAL DAMAGE, LOSS OF TIME OR PROFITS, INCONVENIENCE, INCIDENTAL EXPENSES, LABOR OR MATERIAL CHARGES OR ANY OTHER COSTS RELATED TO THE APPLICATION OF THE PRESENT WARRANTY OR IN CONNECTION WITH ANY COSTS RELATED TO THE REMOVAL OR REPLACEMENT OF EQUIPMENT OR TUB. AT NO TIME WILL CLARION BATHWARE BE LIABLE FOR ANY AMOUNT IN EXCESS OF THE PURCHASE PRICE OF THE UNIT IN QUESTION.
5. This warranty does not apply to the staining or malfunction of the unit due to ferrous, hard or salty water. Nor does the warranty cover fading, blistering or cracking due to excessive wear, light exposure or cleaning methods.
6. The owner/end-user will be responsible for all expenses incurred to supply access for service of the unit and its components.
7. The warranty will be voided if the unit is moved from the original installation location.
8. Any Third-party alterations or installations will not be covered under this warranty.
9. All Clarion Bathware modules have slip-resistant textured floors. The use of "suction-cup" bathmats can cause surface damage **and will not be covered under warranty.**
10. Clarion Bathware makes no express warranty, No warranty of merchantability. No warranty of fitness for particular purposes, compliance with any code, neither any other warranty implied or statutory for its products other than specified above.
11. Any refusal to permit the repair or replacement (at Clarion Bathware's discretion) of the unit will terminate the warranty and any associated claims. Any repaired unit or replacement will remain under warranty for the duration of the original warranty period only.
12. **Any repair not authorized by Clarion Bathware will not be covered under the warranty.**

Clarion Bathware reserves the right to change the warranty at any time, with the understanding that any such change shall not supersede the terms of the warranty implied at the purchase date of the unit in question.

"Everyday Luxury!"