

PRODUCT SPECIFICATIONS

Bulletin No. KGA/KGB-024-090 (2/2017)

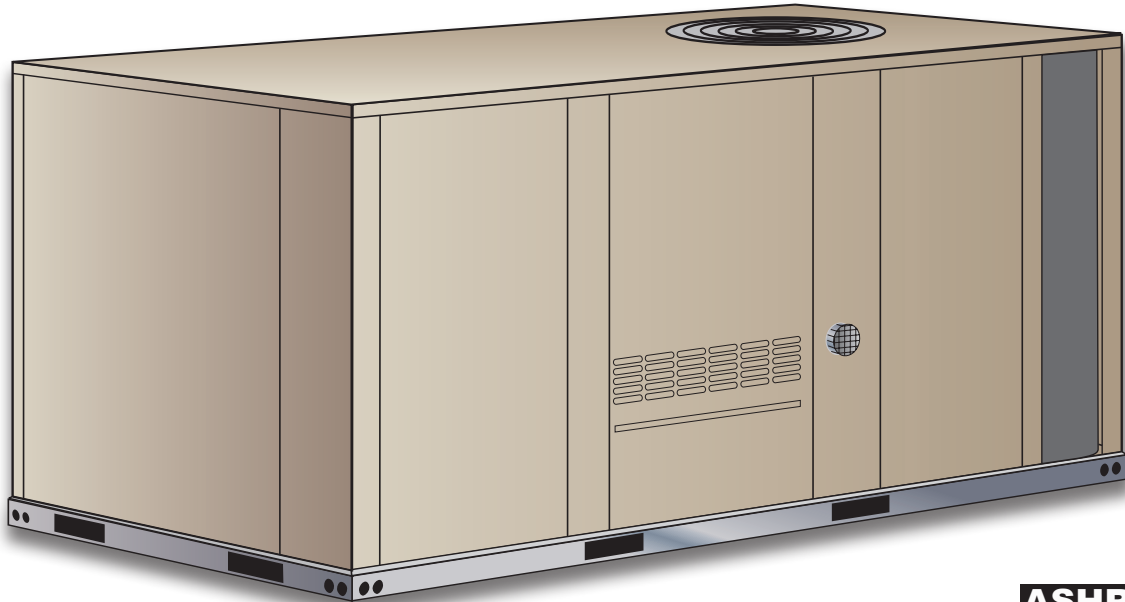

**ASHRAE 90.1
COMPLIANT**

3 to 7.5 Tons
Net Cooling Capacity – 36,000 to 90,000 Btuh
Gas Input Heat Capacity – 65,000 to 150,000 Btuh

MODEL NUMBER IDENTIFICATION

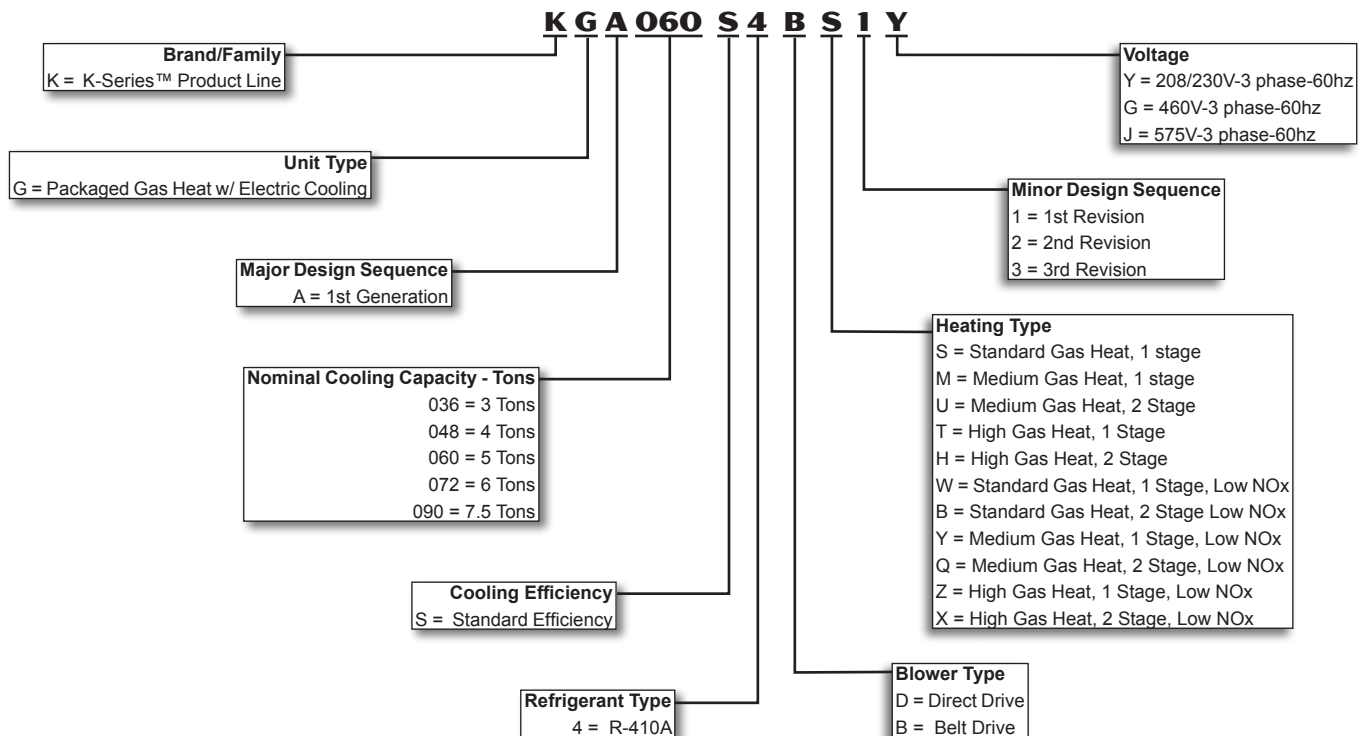

FEATURES AND BENEFITS

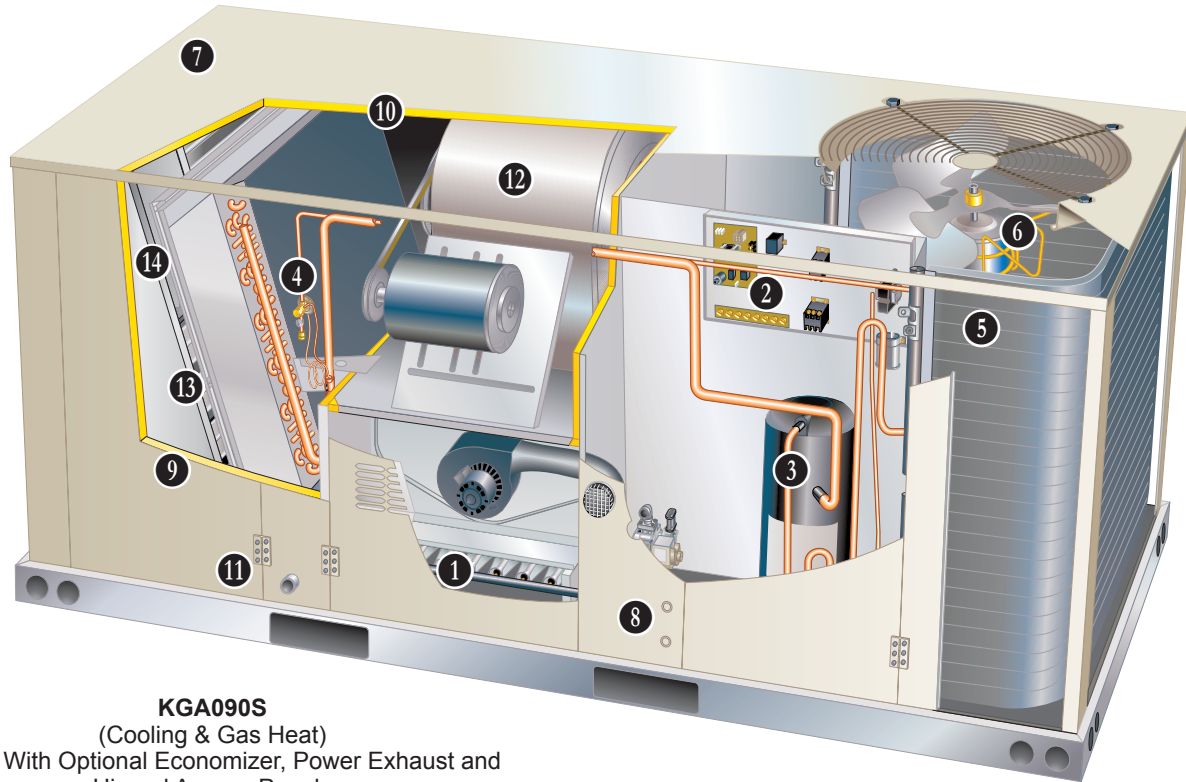

KGA090S
(Cooling & Gas Heat)
Shown With Optional Economizer, Power Exhaust and
Hinged Access Panels

K-Series™ rooftop units from Allied are the new standard for reliable, efficient rooftop units built for long-lasting performance that can significantly improve indoor environments. K-Series™ rooftop units feature:

- **R-410A Refrigerant** - Environmentally friendly.
- **Single Speed Scroll Compressor** - Furnished on all models.
- **Eco-Last™ Coil System** (KGA072 and 090 Models) - Smaller, lighter condenser coil with improved heat transfer.
- **High Pressure Switches** - Protect compressor.
- **Isolated Compressor Compartment** - Allows performance check during normal compressor operation without disrupting airflow.
- **Direct or Belt Drive Blower Motors** - Direct drive (036, 048 and 060 models). Belt drive motors (036, 048, 060, 072 and 090 models) to maximize air performance.
- **Independent Motor Mounts** - Allows for easy and efficient service access without removing the top panel.
- **Downflow or Horizontal Airflow** - Easy field conversion.
- **Two Fork Lift Slots on Three Sides** - Easy to pick up and transport units from almost any angle.
- **Corrosion-Resistant Removable, Reversible Drain Pan** - Provides application flexibility, durability and improved serviceability.
- **Common Components** - Many maintenance items are standard throughout the entire product line, reducing the need to carry different parts to the job or maintain in inventory.

FEATURES AND BENEFITS

CONTENTS

Blower Data - Belt Drive	20
Blower Data - Direct Drive	18
Dimensions - Accessories.	36
Dimensions - Unit	35
Electrical Data.	29
Features And Benefits	2
High Altitude Derate.	15
Model Number Identification	1
Options / Accessories	9
Outdoor Sound Data	28
Ratings	16
Specifications - Belt Drive Blower.	14
Specifications - Direct Drive Blower.	13
Specifications - Standard Gas Heat	15
Unit Clearances.	32
Weight Data.	34

APPROVALS

AHRI Certified to AHRI Standard 210/240-2008 (2 thru 5 ton models) and AHRI Standard 340/360-2007 (6 and 7.5 ton models).

ETL and CSA listed.

Units are Certified by CSA.

Components bonded for grounding to meet safety standards for servicing required by UL, ULC and National and Canadian Electrical Codes.

All models are ASHRAE 90.1 compliant.

ISO 9001 Registered Manufacturing Quality System.

Models equipped with low NOx gas heat meet the California Nitrogen Oxides (NOx) Standards that apply in the South Coast Air Quality Management District and the San Francisco Bay Area Air Quality Management District.

WARRANTY

Limited ten years aluminized heat exchanger, limited fifteen years optional stainless steel heat exchanger.

Limited five years on compressors.

Limited three years on the Eco-Last™ Coil System.

Limited five years Optional High Performance Economizers.

Limited one year all other covered components.

HEATING SYSTEM

- 1 Aluminized steel inshot burners, direct spark ignition, electronic flame sensor, combustion air inducer, redundant automatic single or dual stage gas valve with manual shut-off.

Heat Exchanger

Tubular construction, aluminized steel, life cycle tested.

Stainless Steel Heat Exchanger is required if mixed air temperature is below 45°F.

- 2 **Electronic Pilot Ignition**

Electronic spark igniter provides positive direct ignition of burners on each operating cycle. The system permits main gas valve to stay open only when the burners are proven to be lit. Should a loss of flame occur, the gas valve closes, shutting off the gas to the burners. Ignition module has LED to indicate status and aid in troubleshooting.

Watchguard circuit on module automatically resets ignition controls after one hour of continuous thermostat demand after unit lockout, eliminating nuisance service calls. Ignition control is factory installed in the controls section.

Limit Controls

Factory installed, redundant limit controls with fixed temperature setting.

Heat limit controls protect heat exchanger and other components from overheating.

Safety Switches

Flame roll-out switch, flame sensor and combustion air inducer proving switch protect system operation.

Low NOx Models

All single phase models are available in low NOx versions.

Required Selections

Gas Input Choice - Order one:

- Standard Gas Heat (1 Stage)
65,000 Btuh
(Not available for 090 models)
- Standard Gas Heat (2 Stage)
70,000/53,000 Btuh
(Not available for 090 models)
- Medium Gas Heat (1 Stage)
108,000 Btuh
- Medium Gas Heat (2 Stage)
81,000/108,000 Btuh
- High Gas Heat (1 Stage)
150,000 Btuh
- High Gas Heat (2 Stage)
113,000/150,000 Btuh

Standard or Low NOx

Specify standard gas heat or Low NOx option (three phase models only).

NOTE - Standard Gas Heat (2 Stage) is only available with Low NOx models.

Options/Accessories

Factory Installed

Stainless Steel Heat Exchanger

Required if mixed air temperature is below 45°F.

Field Installed

Combustion Air Intake Extensions

Recommended for use with existing flue extension kits in areas where high snow areas can block intake air.

FEATURES AND BENEFITS

HEATING SYSTEM **(continued)**

Low Temperature Vestibule Heater

Electric heater automatically controls minimum temperature in gas burner compartment when temperature is below -40°F. C.S.A. certified to allow operation of unit down to -60°F.

LPG/Propane Kits

Conversion kit to field change over units from Natural Gas to LPG/Propane.

Vertical Vent Extension Kit

Use to exhaust flue gases vertically above unit. Required when unit vent is too close to fresh air intakes per building codes. The vent kit also prevents ice formation on intake louvers.

COOLING SYSTEM

Designed to maximize sensible and latent cooling performance at design conditions.

System can operate from 30°F to 125°F without any additional controls.

R-410A Refrigerant

Non-chlorine, ozone friendly, R-410A.

Unit is factory pre-charged with refrigerant. See Specifications Tables.

3 Single Speed Scroll Compressor

Scroll compressors for high performance, reliability and quiet operation.

Resiliently mounted on rubber grommets for quiet operation.

Compressor Crankcase Heater (Furnished on all KGA072 and 090 Models)

Protects against refrigerant migration that can occur during low ambient operation.

4 Refrigerant Metering Orifice

Accurately meters refrigerant in system. Refrigerant control is accomplished by exact sizing of refrigerant metering orifice.

Filter/Drier

High capacity filter/drier protects the system from dirt and moisture.

High Pressure Switch

Protects the compressor from overload conditions such as dirty condenser coils, blocked refrigerant flow, or loss of outdoor fan operation.

Freezestat

Protects the evaporator coil from damaging ice build-up due to conditions such as low/no air flow, or low refrigerant charge.

5 Eco-Last™ Coil System (All KGA072 and 090 Models)

Condenser coil features lightweight, all aluminum brazed fin construction.

Constructed of three components: a flat extrusion tube, fins in-between the flat extrusion tubes and two refrigerant manifolds.

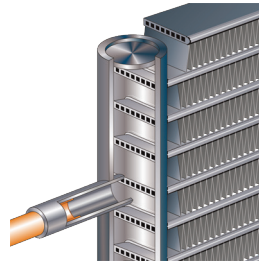

Eco-Last™ Coil System Features:

- Improved heat transfer performance due to high primary surface area (flat tubes) versus secondary surface (fins).
- Smaller internal volume (reduced refrigerant charge).
- High durability (all aluminum construction).
- Fewer brazed joints.
- Compact design (reduces unit weight).
- Easy maintenance/cleaning.

Mounting brackets with rubber inserts secure coil to unit providing vibration dampening and corrosion protection.

Conventional Fin/Tube Coil (Condenser Coil for KGA036 thru 060 Models) and Evaporator Coil (all models)

Copper tube construction, enhanced rippled-edge aluminum fins, flared shoulder tubing connections, silver soldered construction for improved heat transfer. Factory leak tested

Evaporator coil cross row circuiting with rifled tubing optimizes both sensible and latent cooling capacity.

Condensate Drain Pan

Plastic pan, sloped to meet drainage requirements of ASHRAE 62.1.

Side or bottom drain connections. Reversible to allow connection at back of unit.

6 Outdoor Coil Fan Motor

Thermal overload protected, totally enclosed, permanently lubricated sleeve (036 and 048 models) or ball bearings (060, 072, 074 and 090 models), shaft up, wire basket mount.

Outdoor Coil Fan

PVC coated fan guard furnished.

Required Selections

Cooling Capacity

Specify nominal cooling capacity of the unit.

Options/Accessories

Field Installed

Condensate Drain Trap

Field installed only.

Available in copper or PVC.

Compressor Crankcase Heater (Optional for KGA036 thru 060 Models Only)

Protects against refrigerant migration that can occur during low ambient operation.

Drain Pan Overflow Switch

Monitors condensate level in drain pan, shuts down unit if drain becomes clogged.

FEATURES AND BENEFITS

COOLING SYSTEM **(continued)**

Options/Accessories (continued)

Low Ambient Kit

Cycles the outdoor fan while allowing compressor operation in the cooling cycle. This intermittent fan operation allows the system to operate without icing the evaporator coil and losing capacity. Designed for use in ambient temperatures no lower than 0°F. A crankcase heater must be installed on the compressor.

CABINET

7 Construction

Heavy-gauge steel panels and full perimeter heavy-gauge galvanized steel base rail provides structural integrity for transportation, handling, and installation. Base rails have rigging holes. Three sides of the base rail have fork slots.

Raised edges around duct and power entry openings in the bottom of the unit provide additional protection against water entering the building.

Airflow Choice

Units are shipped in downflow (vertical) configuration, can be field converted to horizontal air flow configuration without the need of a kit.

8 Power/Gas Entry

Electrical and gas lines can be brought through the unit base or through horizontal access knock-outs.

Optional Bottom Gas Entry Kit is available.

9 Exterior Panels

Constructed of heavy-gauge, galvanized steel with a two-layer enamel paint finish.

10 Insulation

All panels adjacent to conditioned air are fully insulated with non-hygroscopic fiberglass insulation. Unit base is fully insulated. The insulation also serves as an air seal to the roof curb, eliminating the need to add a seal during installation.

Access Panels

Access panels are provided for the economizer/filter section, heating/blower section, and the compressor/controls section.

NOTE - KGA072/090 models include a filler panel for proper cabinet fit for optional accessories (Economizers, Power Exhaust, Outdoor Air Dampers and Barometric Relief Dampers).

Options/Accessories

Factory Installed

Corrosion Protection

A completely flexible immersed coating with an electro-deposited dry film process (AST ElectroFin E-Coat). Meets Mil Spec MIL-P-53084, ASTM B117 Standard Method Salt Spray Testing.

Indoor Corrosion Protection:

- Coated coil
- Painted blower housing
- Painted base

Outdoor Corrosion Protection:

- Coated coil
- Painted base

11 Hinged Access Panels

Large access panels are hinged and have quarter-turn latches for quick and easy access to maintenance areas (economizer / filter, compressor / controls, heating / blower).

Field Installed

Combination Coil/Hail Guards

Heavy gauge steel frame painted to match cabinet with expanded metal mesh to protect the outdoor coil from damage.

Bottom Gas Entry Kit

Field installed piping kit to facilitate bottom gas entry.

CONTROLS

Unit Control

All control voltage is provided via a 24V (secondary) transformer with built-in circuit breaker protection.

Heat/Cool Staging - Capable of up to 2 heat / 2 cool staging with a third party DDC control system or thermostat.

Low Voltage Terminal Block

Provides screw terminal connections for thermostat or controller wiring.

Night Setback Mode

- Saves energy by closing outdoor air dampers and operating supply fan on thermostat demand only.

Options / Accessories

Field Installed

Smoke Detector

Photoelectric type, installed in supply air section, return air section or both sections. Available with power board and single sensor (supply or return) or power board and two sensors (supply and return). Power board located in unit control compartment.

FEATURES AND BENEFITS

12 BLOWER

A wide selection of supply air blower options are available to meet a variety of air flow requirements.

Motor

Overload protected, equipped with ball bearings (belt drive) or sleeve bearings (direct drive).

Direct drive motors are offered on 036, 048 and 060 models.

Single Speed belt drive motors are offered on 036, 048, 060, 072 and 090 models and are available in several different sizes to maximize air performance.

Supply Air Blower

Forward curved blades, blower wheel is statically and dynamically balanced.

All belt drive motors have adjustable pulley for speed change.

Ordering Information

Specify direct drive or belt drive motor.

For belt drive, specify motor horsepower and drive kit number when base unit is ordered.

Required Selections

Supply Air Blower

Order one, belt drive or direct drive (See Blower Data Table for specifications).

Order one drive kit, belt drive only, see Drive Kit Specifications Table.

INDOOR AIR QUALITY

Air Filters

Disposable 2 inch filters furnished as standard.

Options/Accessories

Field Installed

High Performance Air Filters

Disposable MERV 8 or MERV 13 (Minimum Efficiency Reporting Value based on ASHRAE 52.2) efficiency 2 inch pleated filters.

UVC Germicidal Lamps

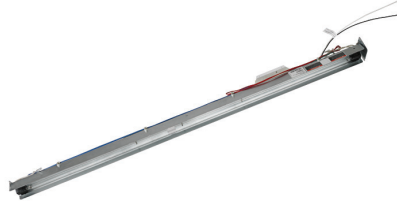

Helps eliminate mold and bacterial growth on the evaporator and drain pans. Improves indoor air quality and maintains efficiency of system by reducing fouling of evaporator coil.

Indoor Air Quality (CO₂) Sensor

Monitors CO₂ levels adjusts economizer dampers as needed for Demand Control Ventilation.

ELECTRICAL

Marked & Color-Coded Wiring

All electrical wiring is color-coded and marked to identify which components it is connecting.

Electrical Plugs

Positive connection electrical plugs are used to connect common accessories or maintenance parts for easy removal or installation.

Required Selections

Voltage Choice

Specify when ordering base unit.

Options/Accessories

Factory or Field Installed

Disconnect Switch (80 Amp)

Accessible from outside of unit, spring loaded weatherproof cover furnished. Main power to the unit is field connected to the disconnect which allows all power to be shut off for service. See Electrical Data tables for ordering information, .

GFI Service Outlets (2)

115V ground fault circuit interrupter (GFCI) type, non-powered, field-wired.

Field Installed

GFI Weatherproof Cover

Single-gang cover.

Heavy-duty UV-resistant polycarbonate case construction. Hinged base cover with gasket.

ECONOMIZER OPTIONS

Factory or Field Installed

13 Economizer (Standard and High Performance Common Features)

Outdoor Air Hood is furnished.

Factory installed Economizer can be ordered with two exhaust options:

- Barometric Relief Dampers and Exhaust Hood.
- No Exhaust.

Field installed Economizer includes Barometric Relief Dampers with Exhaust Hood.

Barometric Relief Dampers allow relief of excess air, aluminum blade dampers prevent blow back and outdoor air infiltration during off cycle, bird screen furnished.

Occupied/Unoccupied mode with field furnished setback thermostat.

Demand Control Ventilation (DCV) ready using optional CO₂ sensors.

Mixed Air Sensor is furnished for field installation in the rooftop unit. Sensor is factory installed when Economizers are factory installed.

Single sensible sensor is furnished with Economizer and enables economizer operation if the outdoor temperature is less than the setpoint of the control.

Horizontal Economizer Conversion kit is available for field installation.

Standard Economizer Features (Not for Title 24)

Gear-driven action, return air and outdoor air dampers, plug-in connections to unit, neoprene seals, 24-volt, fully-modulating spring return motor.

Standard Economizer Control Module

The Standard Economizer Control Module can be adjusted to operate based on outdoor air temperatures.



Economizer Controls:

- Damper Minimum Position - Can be set lower than traditional minimum air requirements resulting in cost savings.
- IAQ Sensor - Signals dampers to modulate and maintain 55°F when CO₂ is higher than the CO₂ setpoint.
- Demand Control Ventilation (DCV) LED - A steady green Demand Control Ventilation LED indicates the IAQ reading is higher than setpoint and requires more fresh air.
- Free Cool LED - A steady green LED indicates outdoor air is suitable for free cooling.

Free Cooling runs when outdoor air temperature is lower than the set temperature on the economizer control.

NOTE: The Free Cooling default setting for outdoor air temperature sensor is 55°F.

High Performance Economizer Features

Approved for California Title 24 building standards.

ASHRAE 90.1-2010 compliant.

Gear-driven action, high torque 24-volt fully-modulating spring return damper motor, return air and outdoor air dampers, plug-in connections to unit, nylon bearings, enhanced neoprene blade edge seals and flexible stainless steel jamb seals to minimize air leakage.

NOTE - High Performance Economizers are not approved for use with enthalpy controls in Title 24 applications.

High Performance Economizer Control Module

Module provides inputs and outputs to control economizer based on parameter settings.



Module automatically detects sensors by polling to determine which sensors are installed in system.

Module displays any alarm messages (fault detection and diagnostics) as an aid in troubleshooting.

Non-volatile memory retains parameter settings in case of power failure.

Keypad with four navigation buttons and LCD screen is furnished for setting economizer parameters.

- Menu Up/Exit (↑) button returns to the main menu.
- Arrow Up (▲) button moves to the previous or next parameter within the selected menu.
- Arrow Down (▼) button moves to the next parameter within the selected menu.
- Select (enter) (↵) button confirms parameter selection.

Main Menu Structure:

- STATUS (economizer and system operation status)
- SETPOINTS (settings for various setpoint parameters)
- SYSTEM SETUP (settings/information about the system)
- ADVANCED SETUP (freeze protection, CO₂ settings, stage 3 delay and additional calibration settings)
- CHECKOUT (damper positions)
- ALARMS (output signal that can be configured for remote alarm monitoring)

OPTIONS / ACCESSORIES

ECONOMIZER OPTIONS **(continued)**

NOTE - The Free Cooling setpoint for Title 24 applications must be set based on the Climate Zone where the system is installed. See Section 140.4 "Prescriptive Requirements for Space Conditioning Systems" of the California Energy Commission's 2013 Building Energy Efficiency Standards.

Refer to Installation Instructions for complete setup information and menu parameters available.

Factory or Field Installed

Single Enthalpy Temperature Control

(Not for Title 24)

Outdoor air enthalpy sensor enables Economizer if the outdoor enthalpy is less than the setpoint of the control.

Field Installed

Differential Enthalpy Control (Not for Title 24)

Order two Single Enthalpy Controls. One is field installed in the return air section, the other in the outdoor air section. Allows the economizer control board to select between outdoor air or return air, whichever has lower enthalpy.

Horizontal Economizer Conversion Kit

Insulated panel covers the bottom return air opening on the unit base to convert downflow Economizer to horizontal airflow.

EXHAUST OPTIONS

Field Installed

14 Power Exhaust Fan

Installs internal to unit for downflow applications only with Economizer option. Provides exhaust air pressure relief. Interlocked to run when supply air blower is operating, fan runs when outdoor air dampers are 50% open (adjustable), motor is overload protected.

Fan is 16 in. diameter with 4 fan blades and a 1/3 hp motor.

NOTE - If Power Exhaust is field installed with a factory installed Economizer, the Economizer must be ordered with the "No Exhaust" option and the Barometric Relief Dampers with Exhaust Hood must also be ordered separately for field installation.

OUTDOOR AIR OPTIONS

Factory or Field Installed

Outdoor Air Dampers - Downflow or Horizontal

Single blade damper, 0 to 25% (fixed) outdoor air adjustable, installs in unit.

Automatic model features fully modulating spring return damper motor with plug-in connection.

Manual model features a slide damper. Maximum mixed air temperature in cooling mode: 100°F.

Outdoor Air Hood is furnished.

ROOF CURBS

Nailer strip furnished, mates to unit, US National Roofing Contractors Approved, shipped knocked down.

Hybrid Roof Curbs, Downflow

Roof curb can be assembled using interlocking tabs to fasten corners together. No tools required.

Curb can also be fastened together with furnished hardware.

Available in 8, 14, 18, and 24 inch heights.

Full Perimeter Curbs, Downflow (090 Models Only)

Hybrid roof curbs can be assembled using interlocking tabs to fasten corners together. No tools required.

Hybrid roof curbs can also be fastened together with furnished hardware.

Available in 8, 14, 18, and 24 inch heights.

NOTE - 090 models can be used on smaller 79-3/4 in. Hybrid Roof Curbs (not full perimeter) with 15-3/4 in. overhang at condenser end of unit. See dimension drawing on page 40.

Adjustable Pitch Curb

Fully adjustable pitch curb provides a level platform for rooftop units allowing flexible installations on roofs with uneven or sloped angles.

Maximum slope is 3/4 in. per foot in any direction.

Uses interlocking tabs to fasten corners together. No tools required.

Hardware is furnished to connect upper curb with lower curb.

Available in 14 inch height.

Adaptor Curbs (not shown)

Curbs are regionally sourced. Dimensions will vary based upon the source. Contact your local sales representative for a detailed cut sheet with applicable dimensions.

CEILING DIFFUSERS

Ceiling Diffusers (Flush and Step-Down)

Diffuser face and grilles with white powder coat finish, insulated (UL listed duct liner), diffuser box with collars for duct connection, fixed blades (flush diffusers) and double deflection blades (step-down diffusers), provisions for suspending, internally sealed (prevents recirculation), removable return air grille, adapts to T-bar ceiling grids or plaster ceilings.

Transitions (Supply and Return)

Used with diffusers, installs in roof curb, galvanized steel construction, flanges furnished for duct connection to diffusers, fully insulated.

OPTIONS / ACCESSORIES

Item	Model No.	Catalog No.	Unit Model No.				
			KGA 036	KGA 048	KGA 060	KGA 072	KGA 090
COOLING SYSTEM							
Compressor Crankcase Heater	208/230V-3ph - K1CCHT02A-2P	14D86	X	X			
	208/230V-3ph - T1CCHT01AN2P	14D83			X		
	460V-3ph - K1CCHT012A-2G	14D87	X	X			
	460V-3ph - T1CCHT01AN2G	14D84			X		
	575V-3ph - K1CCHT02A-2J	14D88	X	X			
	575V-3ph - T1CCHT01AN2J	14D85			X		
Condensate Drain Trap	PVC - C1TRAP20AD2	76W26	X	X	X	X	X
	Copper - C1TRAP10AD2	76W27	X	X	X	X	X
Corrosion Protection			O	O	O	O	O
Drain Pan Overflow Switch	K1SNSR71AB1-	74W42	X	X	X	X	X
Low Ambient Kit	K1SNSR33AN2	14D89	X	X	X	X	X
Efficiency		Standard	O	O	O	O	O
Refrigerant Type		R-410A	O	O	O	O	O
HEATING SYSTEM							
Bottom Gas Piping Kit	T1GPKT01AN1	19W50	X	X	X	X	X
Low Temperature Vestibule Heater	208/230V-3 ph - T1CWKT01AN1Y	19W53	X	X	X	X	X
	460V-3ph - T1CWKT01AN1G	19W54	X	X	X	X	X
	575V-3ph - T1CWKT01AN1J	19W62	X	X	X	X	X
Combustion Air Intake Extensions	T1EXTN10AN1	19W51	X	X	X	X	X
Gas Heat Input	Standard One-Stage - 65 kBtuh input	Factory	O	O	O	O	
	Standard Two-Stage - 53/70 kBtuh input	Factory	¹ O	¹ O	¹ O	¹ O	¹ O
	Medium One-Stage - 108 kBtuh input	Factory	O	O	O	O	O
	Medium Two Stage - 81/108 kBtuh input	Factory	O	O	O	O	O
	High One-Stage - 150 kBtuh input	Factory		O	O	O	O
	High Two-Stage - 113/150 kBtuh input	Factory		O	O	O	O
LPG/Propane Conversion Kits	For one-stage models - C1PROP10AP2	14N20	X	X	X	X	X
	For two-stage models - C1PROP20AP2	14N21	X	X	X	X	X
Stainless Steel Heat Exchanger		Factory	O	O	O	O	O
Vertical Vent Extension	C1EXTN20FF1	31W62	X	X	X	X	X

¹ Standard Two-Stage Heat is only available with Low NOx Models.

NOTE - The catalog and model numbers that appear here are for ordering field installed accessories only.

OX - Field Installed or Configure to Order (factory installed)

O - Configure to Order (Factory Installed)

X - Field Installed.

OPTIONS / ACCESSORIES

Item	Model No.	Catalog No.	Unit Model No.				
			KGA 036	KGA 048	KGA 060	KGA 072	KGA 090
BLOWER - SUPPLY AIR							
Motors	Direct Drive - 0.5 hp (208/230V-3ph, 460V-3ph, 575V-3ph)	Factory	O	O			
	Direct Drive - 0.75 hp (208/230V-3ph, 460V-3ph, 575V-3ph)	Factory			O		
	Belt Drive - 1 hp (208/230V, 460V, 575V-3ph) Standard Efficiency	Factory	O	O	O	O	O
	Belt Drive - 2 hp (208/230V, 460V, 575V-3ph) Standard Efficiency	Factory	O	O	O	O	O
	Belt Drive - 3 hp (208/230V, 460V, 575V-3ph) Standard Efficiency	Factory					O
Drive Kits See Blower Data Tables for selection	Kit A01 - T1DRKT001-1 - 673-1010 rpm	Factory	O				
	Kit A02 - T1DRKT002-1 - 745-1117 rpm	Factory		O			
	Kit A03 - T1DRKT003-1 - 833-1250 rpm	Factory			O		
	Kit A04 - T1DRKT004-1 - 968-1340 rpm	Factory				O	
	Kit A05 - T1DRKT005-1 - 897-1346 rpm	Factory	O				
	Kit A06 - T1DRKT006-1 - 1071-1429 rpm	Factory		O			
	Kit A07 - T1DRKT007-1 - 1212-1548 rpm	Factory			O		
	Kit A08 - T1DRKT008-1 - 1193-1591 rpm	Factory				O	
	Kit AA01 - T1DRKT001AP1 - 522-784 rpm	Factory				O	O
	Kit AA02 - T1DRKT002AP1 - 632-875 rpm	Factory				O	O
	Kit AA03 - T1DRKT003AP1 - 798-1105 rpm	Factory				O	O
	Kit AA04 - T1DRKT004AP1 - 921-1228 rpm	Factory					O
CABINET							
Combination Coil/Hail Guards	C1GARD51A-1	13R98	X	X	X		
	C1GARD51AT1	13T03				X	
	K1GARD50AP1	13T17					X
Hinged Access Panels			O	O	O	O	O
CONTROLS							
Commercial Controls							
BACnet®	K0CTRL31A-1	96W14	OX	OX	OX		
	K0CTRL31AP1	12B99				OX	OX
BACnet® Thermostat with Display	K0SNSR01FF1	97W23	X	X	X	X	X
BACnet® Thermostat without Display	K0SNSR00FF1	97W24	X	X	X	X	X
Novar® 2051	K0CTRL30A-1	96W14	OX	OX	OX		
	K0CTRL30AP1	12B99				OX	OX
Plenum Cable (75 ft.)	K0MISC00FF1	97W25	X	X	X	X	X
Smoke Detector - Supply or Return (Power board and one sensor)	C1SNSR44AP1	53W78	X	X	X	X	X
Smoke Detector - Supply and Return (Power board and two sensors)	C1SNSR43AP1	53W79	X	X	X	X	X

NOTE - The catalog and model numbers that appear here are for ordering field installed accessories only.

OX - Field Installed or Configure to Order (factory installed)

O - Configure to Order (Factory Installed)

X - Field Installed.

OPTIONS / ACCESSORIES

Item	Model No.	Catalog No.	Unit Model No.				
			KGA 036	KGA 048	KGA 060	KGA 072	KGA 090
ECONOMIZER							
Standard Economizer With Outdoor Air Hood (Sensible Control) (Not for Title 24)							
Standard Economizer - Includes Barometric Relief Dampers and Exhaust Hood	K1ECON30A-3-	14D90	OX	OX	OX	OX	OX
Standard Economizer - No Exhaust		Factory	O	O	O	O	O
Standard Economizer Controls (Not for Title 24)							
Single Enthalpy Control	C1SNSR64FF1	53W64	OX	OX	OX	OX	OX
Differential Enthalpy Control (order 2)	C1SNSR64FF1	53W64	X	X	X	X	X
High Performance Economizer With Outdoor Air Hood (Sensible Control) (Approved for California Title 24 Building Standards)							
High Performance Economizer - Includes Barometric Relief Dampers and Exhaust Hood	K1ECON32A-2	14D91	OX	OX	OX	OX	OX
High Performance Economizer Controls (Not for Title 24)							
Single Enthalpy Control	C1SNSR60FF1	10Z75	OX	OX	OX	OX	OX
Differential Enthalpy Control (order 2)	C1SNSR60FF1	10Z75	X	X	X	X	X
Economizer Accessories							
Horizontal Economizer Conversion Kit	T1HECK00AN1	17W45	X	X	X	X	X
OUTDOOR AIR							
Outdoor Air Dampers With Outdoor Air Hood							
Motorized	C1DAMP21A-1	15D17	OX	OX	OX	OX	OX
Manual	C1DAMP11A-2	15D18	OX	OX	OX	OX	OX
POWER EXHAUST FAN							
Standard Static <i>NOTE - Order Barometric Relief Dampers with Exhaust Hood below if unit is ordered with factory installed Standard Economizer with "No Exhaust" option</i>	208/230V-1 or 3ph - C1PWRE10A-1P	79W87	X	X	X	X	X
	460V-3ph - C1PWRE10A-1G	79W88	X	X	X	X	X
	575V-3ph - C1PWRE10A-1J	79W89	X	X	X	X	X
¹ BAROMETRIC RELIEF							
Barometric Relief Dampers with Exhaust Hood	C1DAMP50A-1-	74W38	X	X	X	X	X
ELECTRICAL							
Voltage	208/230V - 1 phase	Factory	O	O	O		
60 hz	208/230V - 3 phase	Factory	O	O	O	O	O
	460V - 3 phase	Factory	O	O	O	O	O
	575V - 3 phase	Factory	O	O	O	O	O
Disconnect (See Electrical Data Tables for selection)			OX	OX	OX	OX	OX
GFI Service	15 amp non-powered, field-wired (208/230V, 460V only) LTAGFIK10/15	74M70	OX	OX	OX	OX	OX
Outlets	20 amp non-powered, field-wired (575V only) C1GFIC120FF1	67E01	X	X	X	X	X
Weatherproof Cover for GFI	C1GFIC199FF1	10C89	X	X	X	X	X

¹ Required when Economizer is factory installed (no exhaust option) with field installed Power Exhaust Fan option.

NOTE - The catalog and model numbers that appear here are for ordering field installed accessories only.

OX - Field Installed or Configure to Order (factory installed)

O - Configure to Order (Factory Installed)

X - Field Installed.

OPTIONS / ACCESSORIES

Item	Model No.	Catalog No.	Unit Model No.				
			KGA 036	KGA 048	KGA 060	KGA 072	KGA 090
INDOOR AIR QUALITY							
Air Filters							
High Efficiency Air Filters	MERV 8 (16 x 20 x 2) - C1FLTR15A-1-	54W20	X	X	X		
Order 4 per unit	MERV 13 (16 x 20 x 2) - T1FLTR40A-1-	52W37	X	X	X		
	MERV 8 (20 x 20 x 2) - C1FLTR15D-1-	54W21				X	
	MERV 13 (20 x 20 x 2) - C1FLTR40D-1-	52W39					X
Indoor Air Quality (Co₂) Sensors							
Sensor - Wall-mount, off-white plastic cover with LCD display	C0SNSR50AE1L	77N39	X	X	X	X	X
Sensor - Wall-mount, black plastic case, no display, rated for plenum mounting	C0SNSR53AE1L	87N54	X	X	X	X	X
CO ₂ Sensor Duct Mounting Kit - for downflow applications	C0MISC19AE1-	85L43	X	X	X	X	X
Aspiration Box - for duct mounting non-plenum rated CO ₂ sensor (77N39)	C0MISC16AE1-	90N43	X	X	X	X	X
UVC Germicidal Lamps							
¹ UVC Light Kit (208/230v-1ph)	E1UVCL10AN1-	50W90	X	X	X	X	X
CEILING DIFFUSERS							
Step-Down - Order one	RTD9-65S	13K60	X	X	X		
	RTD11-95S	13K61				X	X
Flush - Order one	FD9-65S	13K55	X	X	X		
	FD11-95S	13K56				X	X
Transitions (Supply and Return) - Order one	T1TRAN10AN1	17W53	X	X	X		
	T1TRAN20N-1	17W54				X	X
ROOF CURBS							
Hybrid Roof Curbs, Downflow							
8 in. height	C1CURB70A-1	11F50	X	X	X	X	² X
14 in. height	C1CURB71A-1	11F51	X	X	X	X	² X
18 in. height	C1CURB72A-1	11F52	X	X	X	X	² X
24 in. height	C1CURB73A-1	11F53	X	X	X	X	² X
Hybrid Roof Curbs, Full Perimeter, Downflow							
8 in. height	K1CURB70AP1	11S47					X
14 in. height	K1CURB71AP1	11S48					X
18 in. height	K1CURB72AP1	11T01					X
24 in. height	K1CURB73AP1	11T06					X
Adjustable Pitch Curb							
14 in. height	C1CURB55AT1	43W27	X	X	X	X	² X

¹ Lamps operate on 110-230V single-phase power supply. Step-down transformer may be ordered separately for 460V and 575V units. Alternately, 110V power supply may be used to directly power the UVC ballast(s).

² 090 models will fit smaller roof curbs with overhang. See dimension drawing.

NOTE - The catalog and model numbers that appear here are for ordering field installed accessories only.

OX - Field Installed or Configure to Order (factory installed)

O - Configure to Order (Factory Installed)

X - Field Installed.

SPECIFICATIONS - DIRECT DRIVE BLOWER
3 - 5 TON

General Data		Nominal Tonnage	3 Ton	4 Ton	5 Ton
		Model No.	KGA036S4D	KGA048S4D	KGA060S4D
		Efficiency Type	Standard	Standard	Standard
		Blower Type	Multi-Speed Direct Drive	Multi-Speed Direct Drive	Multi-Speed Direct Drive
Cooling Performance	Gross Cooling Capacity - Btuh		37,500	50,000	61,800
	¹ Net Cooling Capacity - Btuh		36,000	48,000	59,000
	AHRI Rated Air Flow - cfm		1200	1600	1800
	² Sound Rating Number (SRN)(dBA)		75	75	82
	Total Unit Power - kW		3.4	4.4	5.3
	¹ SEER (Btuh/Watt)		13.0	13.0	13.0
	¹ EER (Btuh/Watt)		10.7	11	11.2
Refrigerant	Type		R-410A	R-410A	R-410A
	Charge Furnished		7 lbs. 12 oz.	8 lbs. 12 oz.	12 lbs. 8 oz.
Gas Heating Options - See page 15			Standard (1 or 2 Stage) or Medium (1 or 2 Stage)	Standard (1 or 2 Stage), Medium (1 or 2 Stage) or High (1 or 2 Stage)	
Compressor Type (one per unit)			Scroll	Scroll	Scroll
Outdoor Coil	Net face area - sq. ft.		15.6	15.6	15.6
	Tube diameter - in.		3/8	3/8	3/8
	Number of rows		1	1.5	2
	Fins per inch		20	20	20
Outdoor Coil Fan	Motor - (No.) HP		(1) 1/4	(1) 1/4	(1) 1/3
	Motor rpm		825	825	1075
	Total Motor Input - watts		250	250	370
	Diameter - (No.) in. / No. of blades		(1) 24 - 3	(1) 24 - 3	(1) 24 - 3
	Total air volume - cfm		3700	3500	4300
Indoor Coil	Net face area - sq. ft.		7.8	7.8	7.8
	Tube diameter - in.		3/8	3/8	3/8
	Number of rows		3	3	4
	Fins per inch		14	14	14
	Drain Connection (no.) and size - in.		(1) 1 NPT	(1) 1 NPT	(1) 1 NPT
	Expansion device type		Refrigerant Metering Orifice (RFC)		
Indoor Blower	Nominal Motor HP		0.5 hp	0.5 hp	0.75 hp
	Wheel nominal diameter x width - in.		(1) 10 x 10	(1) 10 x 10	(1) 11 x 10
Filters	Type		Disposable		
	Number and size - in.		(4) 16 x 20 x 2		
Electrical Characteristics - 60 Hz			208/230V, 460V & 575V 3 phase	208/230V, 460V & 575V 3 phase	208/230V, 460V & 575V 3 phase

NOTE - Net capacity includes evaporator blower motor heat deduction. Gross capacity does not include evaporator blower motor heat deduction.

¹ AHRI Certified to AHRI Standard 210/240: 95°F outdoor air temperature and 80°F db/67°F wb entering evaporator air; minimum external duct static pressure.

² Sound Rating Number (SRN) rated in accordance with test conditions included in ARI Standard 270-95.

SPECIFICATIONS - BELT DRIVE BLOWER

3 - 7.5 TON

General Data		Nominal Tonnage	3 Ton	4 Ton	5 Ton	6 Ton	7.5 Ton	
	Model No.		KGA036S4B	KGA048S4B	KGA060S4B	KGA072S4B	KGA090S4B	
	Efficiency Type		Standard	Standard	Standard	Standard	Standard	
	Blower Type		Single Speed Belt Drive	Single Speed Belt Drive	Single Speed Belt Drive	Single Speed Belt Drive	Single Speed Belt Drive	
Cooling Performance	Gross Cooling Capacity - Btuh		37,500	50,000	61,800	72,500	92,000	
	Net Cooling Capacity - Btuh		¹ 36,000	¹ 48,000	¹ 59,000	² 69,000	² 90,000	
	AHRI Rated Air Flow - cfm		1200	1600	1800	2450	2430	
	³ Sound Rating Number (SRN) (dBA)		75	75	82	79	79	
	Total Unit Power - kW		3.4	4.4	5.3	6.1	8.2	
	SEER (Btuh/Watt)		¹ 13.0	¹ 13.0	¹ 13.0	---	---	
	IEER (Btuh/Watt)		---	---	---	² 12.3	² 11.2	
	EER (Btuh/Watt)		¹ 10.7	¹ 11.0	¹ 11.2	² 11.2	² 11.0	
Refrigerant	Type		R-410A	R-410A	R-410A	R-410A	R-410A	
	Charge Furnished		7 lbs. 12 oz.	8 lbs. 12 oz.	12 lbs. 8 oz.	7 lbs. 1 oz.	8 lbs. 8 oz.	
Gas Heating Options - See page 15			Standard (1 or 2 Stage) or Medium (1 or 2 Stage)	Standard (1 or 2 Stage), Medium (1 or 2 Stage) or High (1 or 2 Stage)			Medium (1 or 2 Stage) or High (1 or 2 Stage)	
Compressor Type (one per unit)			Scroll	Scroll	Scroll	Scroll	Scroll	
Outdoor Coil	Net face area - sq. ft.		15.6	15.6	15.6	17.8	24.2	
	Tube diameter - in.		3/8	3/8	3/8	---	---	
	Number of rows		1	1.5	2	1	1	
	Fins / inch		20	20	20	23	23	
Outdoor Coil Fan	Motor - (No.) HP		(1) 1/4	(1) 1/4	(1) 1/3	(1) 1/3	(1) 1/2	
	Motor rpm		825	825	1075	1075	1075	
	Total Motor Input - watts		250	250	370	370	520	
	Diameter - (No.) in. / No. of blades		(1) 24 - 3	(1) 24 - 3	(1) 24 - 3	(1) 24 - 3	(1) 24 - 4	
	Total air volume - cfm		3700	3500	4300	4700	5300	
Indoor Coil	Net face area - sq. ft.		7.8	7.8	7.8	9.7	9.7	
	Tube diameter - in.		3/8	3/8	3/8	3/8	3/8	
	Number of rows		3	3	4	4	4	
	Fins per inch		14	14	14	14	14	
	Drain Connection (no.) and size - in.		(1) 1 NPT	(1) 1 NPT	(1) 1 NPT	(1) 1 NPT	(1) 1 NPT	
	Expansion device type		Refrigerant Metering Orifice (RFC)					
⁴ Indoor Blower & Drive Selection	Nominal Motor HP		1 hp, 2 hp	1 hp, 2 hp	1 hp, 2 hp	1 hp, 2 hp	1 hp	
	Maximum Usable Motor HP		1.15 hp, 2.3 hp	1.15 hp, 2.3 hp	1.15 hp, 2.3 hp	1.15 hp, 2.3 hp	1.15 hp	
	Available Drive Kits	A01		A02		A03		A04
		673 - 1010 rpm		745 - 1117 rpm		833 - 1250 rpm		968 - 1340 rpm
		A05		A06		A07		A08
	897 - 1346 rpm		1071 - 1429 rpm		1212 - 1548 rpm		1193 - 1591 rpm	
	Nominal Motor HP		---	---	---	---	2 hp	
	Maximum Usable Motor HP		---	---	---	---	2.3 hp	
	Available Drive Kits	---		---		---		AA02
		---		---		---		632 - 875 rpm
---			---		---		AA03	
---			---		---		798 - 1105 rpm	
		---		---		3 hp		
		---		---		3.45 hp		
		---		---		AA04		
		---		---		921 - 1228 rpm		
Wheel nominal diameter x width - in.		(1) 10 x 10	(1) 10 x 10	(1) 10 x 10	(1) 10 x 10	(1) 15 x 9		
Filters	Type		Disposable			Disposable		
	Number and size - in.		(4) 16 x 20 x 2			(4) 20 x 20 x 2		
Electrical Characteristics - 60 Hz			208/230V, 460V & 575V 3 phase	208/230V, 460V & 575V 3 phase	208/230V, 460V & 575V 3 phase	208/230V, 460V & 575V 3 phase	208/230V, 460V & 575V 3 phase	

NOTE - Net capacity includes evaporator blower motor heat deduction. Gross capacity does not include evaporator blower motor heat deduction.

^{1,2} AHRI Certified to AHRI Standard ¹ 210/240 or ² 340/360: 95°F outdoor air temperature and 80°F db/67°F wb entering evaporator air; minimum external duct static pressure.

³ Sound Rating Number (SRN) rated in accordance with test conditions included in ARI Standard 270-95.

⁴ Using total air volume and system static pressure requirements determine from blower performance tables rpm and motor hp required. Maximum usable hp of motors furnished are shown. In Canada, nominal motor hp is also maximum usable motor hp output. If motors of comparable hp are used, be sure to keep within the service factor limitations outlined on the motor nameplate.

SPECIFICATIONS - STANDARD GAS HEAT

Model No.	036, 048, 060, 072	036, 048, 060, 072	036, 048, 060, 072	090	036, 048, 060, 072	090	048, 060, 072	090	048, 060, 072	090		
Heat Input Type	Standard (1 Stage)	Standard (2 Stage) Low NOx Only	Medium (1 Stage)		Medium (2 Stage)		High (1 Stage)		High (2 Stage)			
Input Btuh	65,000	53,000	108,000		81,000		150,000		113,000			
1st Stage	---	70,000	---		108,000		---		150,000			
2nd Stage	52,000	43,000	86,000		65,000		120,000		90,000			
Output Btuh	---	57,000	---		86,000		---		120,000			
1st Stage	15 - 45	5-35	5-35	30 - 70	15 - 45	25 - 55	10 - 40	45 - 75	25 - 55	30 - 60	15 - 45	
Rise Range - °F	2nd Stage	---	15-45	10-40	---	---	30 - 70	15 - 45	---	---	45 - 75	25 - 55
¹ Thermal Efficiency	Standard	80%	81%	81%	80%	80%	80%	80%	80%	80%	80%	80%
Gas Supply Connections	1/2 in. NPT											
Rec. Gas Supply Pressure - Nat./ LPG	7 in.w.g. / 11 in.w.g.											

¹ Thermal Efficiency at full input.

HIGH ALTITUDE DERATE

NOTE - Units may be installed at altitudes up to 2000 ft. above sea level without any modifications. At altitudes above 2000 ft. units must be derated to match information in the table shown. At altitudes above 4500 ft. unit must be derated 2% for each 1000 ft. above sea level. NOTE - This is the only permissible derate for these units.	Heat Input Type	Altitude Feet	Gas Manifold Pressure in. w.g.		Input Rate (Btuh)
			Natural Gas	LPG/ Propane	
			Standard (1 stage)	2001 - 4500	
Standard (2 stage)	2001 - 4500	3.0/1.7	9.0/5.1	65,000 / 49,000	
Medium (1 stage)	2001 - 4500	3.0	9.0	100,000	
Medium (2 stage)	2001 - 4500	3.0/1.7	9.0/5.1	100,000 / 75,000	
High (1 stage)	2001 - 4500	3.0	9.0	139,000	
High (2 stage)	2001 - 4500	3.0/1.7	9.0/5.1	139,000 / 104,000	

RATINGS

NOTE - For Temperatures and Capacities not shown in tables, see bulletin - Cooling Unit Rating Table Correction Factor Data in Miscellaneous Engineering Data section.

3 TON - KGA036S4

Entering Wet Bulb Temperature	Total Air Volume	Outdoor Air Temperature Entering Outdoor Coil																			
		85°F					95°F					105°F					115°F				
		Total Cool Cap.	Comp. Motor Input	Sensible To Total Ratio (S/T)			Total Cool Cap.	Comp. Motor Input	Sensible To Total Ratio (S/T)			Total Cool Cap.	Comp. Motor Input	Sensible To Total Ratio (S/T)			Total Cool Cap.	Comp. Motor Input	Sensible To Total Ratio (S/T)		
				Dry Bulb					Dry Bulb					Dry Bulb					Dry Bulb		
cfm	kBtuh	kW	75°F	80°F	85°F	kBtuh	kW	75°F	80°F	85°F	kBtuh	kW	75°F	80°F	85°F	kBtuh	kW	75°F	80°F	85°F	
63°F	960	35.6	2.35	0.75	0.87	0.98	33.4	2.67	0.75	0.89	1	31.1	3.04	0.77	0.91	1	28.5	3.48	0.79	0.93	1
	1200	37.7	2.36	0.8	0.93	1	35.3	2.68	0.81	0.95	1	32.9	3.06	0.82	0.98	1	30.2	3.49	0.84	1	1
	1440	39.3	2.37	0.84	0.98	1	36.8	2.69	0.85	1	1	34.5	3.07	0.87	1	1	32	3.5	0.9	1	1
67°F	960	37.6	2.36	0.59	0.72	0.84	35.4	2.68	0.59	0.73	0.86	33.1	3.05	0.59	0.74	0.88	30.4	3.5	0.59	0.76	0.9
	1200	39.8	2.38	0.62	0.78	0.91	37.5	2.7	0.62	0.79	0.92	34.9	3.07	0.63	0.8	0.94	32.1	3.5	0.64	0.82	0.97
	1440	41.4	2.39	0.65	0.82	0.96	38.9	2.71	0.66	0.84	0.98	36.2	3.08	0.66	0.86	1	33.3	3.51	0.68	0.88	1
71°F	960	39.9	2.38	0.45	0.58	0.7	37.5	2.7	0.44	0.58	0.71	34.9	3.07	0.42	0.58	0.72	32.2	3.5	0.43	0.58	0.74
	1200	42	2.39	0.45	0.61	0.75	39.5	2.71	0.46	0.61	0.77	36.9	3.09	0.45	0.62	0.79	34	3.52	0.45	0.63	0.81
	1440	43.6	2.41	0.47	0.65	0.8	41	2.73	0.46	0.65	0.82	38.2	3.1	0.47	0.66	0.83	35.2	3.53	0.47	0.68	0.87

4 TON - KGA048S4

Entering Wet Bulb Temperature	Total Air Volume	Outdoor Air Temperature Entering Outdoor Coil																			
		85°F					95°F					105°F					115°F				
		Total Cool Cap.	Comp. Motor Input	Sensible To Total Ratio (S/T)			Total Cool Cap.	Comp. Motor Input	Sensible To Total Ratio (S/T)			Total Cool Cap.	Comp. Motor Input	Sensible To Total Ratio (S/T)			Total Cool Cap.	Comp. Motor Input	Sensible To Total Ratio (S/T)		
				Dry Bulb					Dry Bulb					Dry Bulb					Dry Bulb		
cfm	kBtuh	kW	75°F	80°F	85°F	kBtuh	kW	75°F	80°F	85°F	kBtuh	kW	75°F	80°F	85°F	kBtuh	kW	75°F	80°F	85°F	
63°F	1280	47.6	3.02	0.74	0.87	0.98	44.5	3.44	0.74	0.88	1	41.2	3.89	0.75	0.9	1	37.8	4.41	0.77	0.93	1
	1600	50.4	3.04	0.79	0.93	1	47.1	3.46	0.8	0.95	1	43.7	3.91	0.81	0.97	1	40	4.42	0.83	1	1
	1920	52.6	3.05	0.83	0.99	1	49.1	3.47	0.85	1	1	45.7	3.93	0.87	1	1	42.3	4.45	0.89	1	1
67°F	1280	50.6	3.04	0.58	0.72	0.84	47.2	3.45	0.58	0.72	0.85	43.9	3.91	0.57	0.73	0.87	40.3	4.44	0.57	0.74	0.9
	1600	53.5	3.06	0.61	0.77	0.9	50	3.48	0.61	0.78	0.92	46.4	3.94	0.62	0.8	0.95	42.5	4.45	0.62	0.81	0.98
	1920	55.6	3.07	0.64	0.82	0.96	51.9	3.5	0.65	0.83	0.98	47.9	3.95	0.66	0.85	1	44	4.47	0.67	0.88	1
71°F	1280	53.7	3.06	0.43	0.57	0.69	50.2	3.48	0.43	0.57	0.7	46.6	3.93	0.42	0.57	0.71	42.8	4.46	0.41	0.57	0.72
	1600	56.4	3.07	0.45	0.6	0.75	52.6	3.5	0.45	0.6	0.76	49	3.96	0.44	0.61	0.78	45	4.48	0.43	0.62	0.8
	1920	58.6	3.08	0.47	0.64	0.8	54.8	3.52	0.47	0.64	0.81	50.8	3.98	0.46	0.65	0.83	46.7	4.5	0.45	0.66	0.86

5 TON - KGA060S4

Entering Wet Bulb Temperature	Total Air Volume	Outdoor Air Temperature Entering Outdoor Coil																			
		85°F					95°F					105°F					115°F				
		Total Cool Cap.	Comp. Motor Input	Sensible To Total Ratio (S/T)			Total Cool Cap.	Comp. Motor Input	Sensible To Total Ratio (S/T)			Total Cool Cap.	Comp. Motor Input	Sensible To Total Ratio (S/T)			Total Cool Cap.	Comp. Motor Input	Sensible To Total Ratio (S/T)		
				Dry Bulb					Dry Bulb					Dry Bulb					Dry Bulb		
cfm	kBtuh	kW	75°F	80°F	85°F	kBtuh	kW	75°F	80°F	85°F	kBtuh	kW	75°F	80°F	85°F	kBtuh	kW	75°F	80°F	85°F	
63°F	1600	60.1	3.48	0.68	0.84	1	57	3.93	0.69	0.86	1	53.5	4.44	0.71	0.89	1	50	5.04	0.73	0.93	1
	2000	63.1	3.51	0.74	0.94	1	59.8	3.96	0.76	0.97	1	56	4.47	0.78	1	1	52.6	5.06	0.81	1	1
	2400	65.6	3.54	0.8	1	1	62.3	3.99	0.83	1	1	59.1	4.51	0.86	1	1	55.6	5.1	0.91	1	1
67°F	1600	63.9	3.52	0.54	0.66	0.79	60.5	3.97	0.54	0.67	0.82	57.1	4.48	0.55	0.69	0.85	53.2	5.07	0.56	0.71	0.89
	2000	66.8	3.55	0.57	0.72	0.9	63.1	4	0.58	0.73	0.93	59.2	4.51	0.58	0.75	0.97	55.1	5.1	0.59	0.79	1
	2400	68.9	3.58	0.6	0.78	0.99	65	4.02	0.61	0.8	1	61.1	4.54	0.63	0.84	1	56.8	5.12	0.64	0.88	1
71°F	1600	67.7	3.56	0.4	0.52	0.64	64.2	4.01	0.41	0.53	0.65	60.4	4.53	0.4	0.54	0.67	56.4	5.12	0.4	0.54	0.69
	2000	70.7	3.6	0.42	0.56	0.7	67	4.05	0.42	0.57	0.71	62.8	4.56	0.42	0.57	0.73	58.5	5.15	0.42	0.59	0.76
	2400	72.7	3.62	0.43	0.59	0.75	68.7	4.07	0.43	0.6	0.78	64.6	4.58	0.44	0.62	0.81	60	5.17	0.44	0.64	0.85

6 TON - KGA072S4

Entering Wet Bulb Temperature	Total Air Volume	Outdoor Air Temperature Entering Outdoor Coil																			
		85°F					95°F					105°F					115°F				
		Total Cool Cap.	Comp. Motor Input	Sensible To Total Ratio (S/T)			Total Cool Cap.	Comp. Motor Input	Sensible To Total Ratio (S/T)			Total Cool Cap.	Comp. Motor Input	Sensible To Total Ratio (S/T)			Total Cool Cap.	Comp. Motor Input	Sensible To Total Ratio (S/T)		
				Dry Bulb					Dry Bulb					Dry Bulb					Dry Bulb		
cfm	kBtuh	kW	75°F	80°F	85°F	kBtuh	kW	75°F	80°F	85°F	kBtuh	kW	75°F	80°F	85°F	kBtuh	kW	75°F	80°F	85°F	
63°F	1920	69.7	4.27	0.74	0.89	1	64.1	4.8	0.75	0.92	1	58.7	5.43	0.77	0.95	1	53	6.14	0.79	0.99	1
	2400	73.5	4.32	0.8	0.98	1	67.7	4.84	0.82	1	1	62.6	5.47	0.85	1	1	57.5	6.2	0.88	1	1
	2880	77.2	4.37	0.86	1	1	71.8	4.9	0.89	1	1	66.4	5.52	0.92	1	1	60.8	6.24	0.97	1	1
67°F	1920	74.6	4.33	0.56	0.71	0.86	68.8	4.85	0.57	0.73	0.88	63.1	5.48	0.58	0.75	0.92	57.3	6.2	0.58	0.77	0.95
	2400	78.3	4.39	0.61	0.78	0.95	72.2	4.9	0.62	0.8	0.98	66	5.51	0.62	0.82	1	60	6.23	0.64	0.86	1
	2880	80.9	4.42	0.64	0.84	1	74.6	4.93	0.66	0.87	1	68	5.54	0.67	0.9	1	62	6.26	0.69	0.95	1
71°F	1920	79.5	4.4	0.42	0.55	0.69	73.6	4.91	0.42	0.56	0.71	67.5	5.53	0.4	0.57	0.73	61.4	6.25	0.4	0.57	0.75
	2400	83.3	4.45	0.45	0.6	0.76	76.9	4.96	0.44	0.61	0.78	70.5	5.57	0.43	0.62	0.8	64.3	6.29	0.41	0.63	0.84
	2880	85.8	4.5	0.46	0.64	0.82	79.4	5.01	0.45	0.66	0.86	72.5	5.6	0.45	0.67	0.88	66.1	6.32	0.45	0.68	0.93

RATINGS

NOTE - For Temperatures and Capacities not shown in tables, see bulletin - Cooling Unit Rating Table Correction Factor Data in Miscellaneous Engineering Data section.

7.5 TON - KGA090S4

Entering Wet Bulb Temperature	Total Air Volume	Outdoor Air Temperature Entering Outdoor Coil																			
		85°F					95°F					105°F					115°F				
		Total Cool Cap.	Comp. Motor Input	Sensible To Total Ratio (S/T)			Total Cool Cap.	Comp. Motor Input	Sensible To Total Ratio (S/T)			Total Cool Cap.	Comp. Motor Input	Sensible To Total Ratio (S/T)			Total Cool Cap.	Comp. Motor Input	Sensible To Total Ratio (S/T)		
				Dry Bulb					Dry Bulb					Dry Bulb					Dry Bulb		
		cfm	kBtuh	kW	75°F	80°F	85°F	kBtuh	kW	75°F	80°F	85°F	kBtuh	kW	75°F	80°F	85°F	kBtuh	kW	75°F	80°F
63°F	2400	92.4	5.97	0.69	0.84	0.98	85.3	6.6	0.7	0.86	1	77.8	7.32	0.7	0.88	1	69.9	8.15	0.71	0.91	1
	3000	97.7	6.04	0.75	0.92	1	90.2	6.68	0.76	0.95	1	82.5	7.4	0.78	0.98	1	74.5	8.23	0.81	1	1
	3600	101.9	6.11	0.81	1	1	94.6	6.75	0.83	1	1	87.2	7.48	0.85	1	1	79.5	8.33	0.89	1	1
67°F	2400	99.4	6.07	0.54	0.67	0.81	91.8	6.7	0.53	0.68	0.83	84.2	7.43	0.53	0.68	0.85	75.9	8.26	0.52	0.7	0.88
	3000	104.5	6.15	0.57	0.73	0.89	96.8	6.78	0.58	0.74	0.91	88.7	7.51	0.57	0.76	0.95	79.9	8.34	0.58	0.79	0.99
	3600	108.5	6.21	0.61	0.79	0.97	100.2	6.84	0.62	0.81	0.99	92	7.57	0.62	0.84	1	82.7	8.39	0.62	0.87	1
71°F	2400	106.2	6.17	0.4	0.53	0.65	98.5	6.81	0.38	0.52	0.66	90.6	7.54	0.37	0.52	0.67	82.2	8.38	0.36	0.52	0.68
	3000	111.7	6.26	0.41	0.57	0.71	103.8	6.9	0.4	0.57	0.72	95.1	7.63	0.4	0.57	0.74	86.3	8.46	0.38	0.58	0.77
	3600	115.6	6.33	0.44	0.6	0.77	107.2	6.96	0.43	0.61	0.79	98.6	7.69	0.42	0.62	0.82	89	8.51	0.41	0.63	0.85

BLOWER DATA - DIRECT DRIVE - KGA036, KGA048

BLOWER TABLE INCLUDES RESISTANCE FOR BASE UNIT ONLY WITH DRY INDOOR COIL AND AIR FILTERS IN PLACE.

FOR ALL UNITS ADD:

1 - Any factory installed options air resistance (larger gas heat section, economizer, wet coil, etc.) See page 27.

2 - Any field installed accessories air resistance (duct resistance, diffuser, etc.) See page 27.

External Static Pressure (in. w.g.)	Air Volume (cfm) at Various Blower Speeds								
	208 VOLTS			230 VOLTS			460/575 VOLTS		
	High	Medium	Low	High	Medium	Low	High	Medium	Low
3 and 4 Ton Standard Efficiency (Downflow)					KGA036S and KGA048S				
0.0	1873	1561	1123	2094	1783	1321	2064	1727	1216
0.1	1993	1601	1148	2168	1797	1338	2105	1744	1229
0.2	1913	1601	1137	2098	1803	1308	2050	1694	1198
0.3	1858	1527	1078	2036	1725	1261	1987	1638	1167
0.4	1801	1496	1046	1973	1679	1219	1905	1598	1148
0.5	1763	1467	987	1910	1647	1177	1862	1559	1108
0.6	1709	1414	897	1830	1560	1080	1781	1509	1057
0.7	1617	1368	806	1727	1519	986	1698	1449	982
0.8	1472	1269	730	1604	1419	918	1614	1389	920
0.9	1359	1162	487	1478	1363	706	1488	1346	792
1.0	961	922	370	1093	1083	590	1167	1099	703
3 and 4 Ton Standard Efficiency (Horizontal)					KGA036S and KGA048S				
0.0	1799	1530	1073	2012	1747	1263	2015	1756	1251
0.1	1868	1544	1088	2032	1733	1268	2071	1760	1279
0.2	1802	1494	1068	1976	1682	1228	2014	1700	1226
0.3	1735	1432	1014	1900	1618	1185	1937	1634	1187
0.4	1666	1397	980	1825	1568	1142	1878	1597	1174
0.5	1615	1350	904	1750	1516	1078	1801	1558	1124
0.6	1564	1305	842	1675	1440	1014	1743	1479	1060
0.7	1462	1228	758	1562	1364	928	1664	1415	982
0.8	1330	1151	670	1449	1287	842	1512	1335	865
0.9	1194	1011	464	1298	1185	671	1393	1297	733
1.0	878	878	355	998	1032	565	1060	1063	618

BLOWER DATA - DIRECT DRIVE - KGA060

BLOWER TABLE INCLUDES RESISTANCE FOR BASE UNIT ONLY WITH DRY INDOOR COIL AND AIR FILTERS IN PLACE.

FOR ALL UNITS ADD:

1 - Any factory installed options air resistance (larger gas heat section, economizer, wet coil, etc.) See page 27.

2 - Any field installed accessories air resistance (duct resistance, diffuser, etc.) See page 27.

External Static Pressure (in. w.g.)	Air Volume (cfm) at Various Blower Speeds					
	208 VOLTS		230 VOLTS		460/575 VOLTS	
	High	Low	High	Low	High	Low
5 Ton Standard Efficiency (Downflow)						KGA060S
0.0	2200	1649	2411	1957	2241	1755
0.1	2256	1669	2417	2002	2221	1742
0.2	2202	1739	2396	1985	2193	1747
0.3	2170	1705	2328	1972	2144	1725
0.4	2158	1689	2293	1959	2104	1695
0.5	2130	1676	2279	1930	2086	1678
0.6	2056	1662	2158	1900	2008	1652
0.7	2032	1657	2089	1857	1975	1610
0.8	1963	1591	2077	1796	1941	1586
0.9	1887	1597	1876	1746	1855	1555
1.0	1695	1400	1746	1601	1778	1486
5 Ton Standard Efficiency (Horizontal)						KGA060S
0.0	2114	1615	2305	1880	2308	1890
0.1	2115	1610	2290	1876	2334	1906
0.2	2074	1622	2249	1870	2292	1890
0.3	2025	1599	2188	1841	2230	1859
0.4	1996	1577	2148	1812	2210	1846
0.5	1952	1542	2087	1768	2148	1817
0.6	1882	1534	2026	1739	2108	1786
0.7	1838	1488	1966	1680	2094	1743
0.8	1773	1443	1905	1622	1988	1682
0.9	1657	1389	1784	1534	1915	1679
1.0	1548	1335	1672	1462	1853	1506

BLOWER DATA - BELT DRIVE - KGA036

BLOWER TABLE INCLUDES RESISTANCE FOR BASE UNIT ONLY WITH DRY INDOOR COIL AND AIR FILTERS IN PLACE.

FOR ALL UNITS ADD:

1 - Any factory installed options air resistance (heat section, economizer, wet coil, etc.).

2 - Any field installed accessories air resistance (duct resistance, diffuser, etc.).

See page 27 for blower motors and drives and wet coil and options/accessory air resistance data.

DOWNFLOW

Air Volume cfm	External Static - in. w.g.															
	0.10		0.20		0.30		0.40		0.50		0.60		0.70		0.80	
	RPM	BHP	RPM	BHP	RPM	BHP	RPM	BHP	RPM	BHP	RPM	BHP	RPM	BHP	RPM	BHP
900	493	0.11	564	0.15	637	0.19	711	0.22	783	0.24	851	0.26	910	0.29	961	0.32
1000	517	0.14	588	0.18	660	0.22	733	0.24	804	0.26	868	0.29	924	0.32	974	0.35
1100	544	0.17	614	0.21	685	0.25	757	0.27	826	0.29	887	0.32	940	0.36	987	0.38
1200	574	0.2	643	0.24	712	0.28	782	0.31	849	0.33	906	0.36	956	0.39	1001	0.42
1300	613	0.23	679	0.28	745	0.31	811	0.34	873	0.36	926	0.40	973	0.43	1016	0.46
1400	662	0.26	722	0.30	781	0.34	841	0.37	897	0.41	944	0.44	989	0.48	1032	0.51
1500	710	0.29	763	0.33	816	0.38	869	0.41	919	0.45	963	0.49	1006	0.53	1049	0.56

Air Volume cfm	External Static - in. w.g.															
	0.90		1.00		1.10		1.20		1.30		1.40		1.50		1.60	
	RPM	BHP	RPM	BHP	RPM	BHP	RPM	BHP	RPM	BHP	RPM	BHP	RPM	BHP	RPM	BHP
900	1008	0.34	1056	0.36	1104	0.39	1149	0.41	1190	0.44	1229	0.46	1267	0.49	1305	0.52
1000	1020	0.37	1067	0.40	1115	0.42	1159	0.45	1200	0.48	1239	0.51	1277	0.54	1314	0.57
1100	1032	0.41	1078	0.43	1124	0.46	1168	0.49	1210	0.52	1249	0.55	1286	0.58	1323	0.62
1200	1045	0.45	1090	0.47	1135	0.50	1178	0.53	1220	0.57	1259	0.60	1296	0.64	1332	0.67
1300	1060	0.49	1104	0.51	1148	0.55	1190	0.58	1230	0.62	1269	0.65	1306	0.69	1342	0.72
1400	1075	0.53	1119	0.56	1162	0.60	1203	0.63	1242	0.67	1280	0.71	1317	0.75	1352	0.78
1500	1093	0.58	1136	0.61	1177	0.65	1217	0.69	1255	0.73	1292	0.77	1328	0.80	1364	0.84

HORIZONTAL

Air Volume cfm	External Static - in. w.g.															
	0.10		0.20		0.30		0.40		0.50		0.60		0.70		0.80	
	RPM	BHP	RPM	BHP	RPM	BHP	RPM	BHP	RPM	BHP	RPM	BHP	RPM	BHP	RPM	BHP
900	465	0.09	531	0.14	600	0.17	670	0.20	740	0.22	808	0.24	869	0.27	925	0.30
1000	483	0.12	549	0.16	617	0.20	687	0.22	756	0.24	822	0.26	881	0.29	935	0.33
1100	504	0.14	570	0.19	637	0.22	706	0.25	773	0.27	837	0.29	894	0.32	946	0.36
1200	527	0.17	592	0.22	658	0.25	726	0.28	792	0.30	854	0.32	908	0.36	957	0.39
1300	552	0.20	617	0.25	682	0.29	748	0.31	812	0.33	871	0.36	923	0.40	970	0.43
1400	580	0.24	644	0.28	708	0.32	773	0.35	834	0.37	890	0.40	938	0.44	984	0.48
1500	611	0.28	674	0.32	736	0.35	799	0.38	857	0.41	908	0.44	954	0.49	998	0.52

Air Volume cfm	External Static - in. w.g.															
	0.90		1.00		1.10		1.20		1.30		1.40		1.50		1.60	
	RPM	BHP	RPM	BHP	RPM	BHP	RPM	BHP	RPM	BHP	RPM	BHP	RPM	BHP	RPM	BHP
900	977	0.33	1028	0.36	1079	0.39	1127	0.42	1169	0.45	1208	0.48	1246	0.51	1282	0.54
1000	985	0.36	1036	0.39	1087	0.42	1135	0.45	1177	0.48	1216	0.52	1253	0.55	1290	0.58
1100	995	0.39	1044	0.42	1093	0.45	1140	0.49	1183	0.52	1223	0.56	1261	0.59	1297	0.62
1200	1005	0.43	1053	0.46	1100	0.49	1146	0.53	1190	0.56	1230	0.60	1268	0.63	1304	0.67
1300	1016	0.47	1063	0.50	1109	0.53	1154	0.57	1197	0.61	1237	0.64	1275	0.68	1311	0.72
1400	1029	0.51	1074	0.54	1120	0.58	1164	0.61	1205	0.65	1245	0.69	1282	0.73	1318	0.77
1500	1042	0.56	1087	0.59	1132	0.62	1174	0.66	1215	0.71	1253	0.75	1290	0.78	1326	0.82

BLOWER DATA - BELT DRIVE - KGA048

BLOWER TABLE INCLUDES RESISTANCE FOR BASE UNIT ONLY WITH DRY INDOOR COIL AND AIR FILTERS IN PLACE.

FOR ALL UNITS ADD:

1 - Any factory installed options air resistance (heat section, economizer, wet coil, etc.).

2 - Any field installed accessories air resistance (duct resistance, diffuser, etc.).

See page 27 for blower motors and drives and wet coil and options/accessory air resistance data.

DOWNFLOW

Air Volume cfm	External Static - in. w.g.															
	0.10		0.20		0.30		0.40		0.50		0.60		0.70		0.80	
	RPM	BHP	RPM	BHP	RPM	BHP	RPM	BHP	RPM	BHP	RPM	BHP	RPM	BHP	RPM	BHP
1200	574	0.20	644	0.24	713	0.28	784	0.31	850	0.33	906	0.36	953	0.39	998	0.42
1300	608	0.24	677	0.28	744	0.31	813	0.34	874	0.37	925	0.40	969	0.43	1014	0.46
1400	645	0.28	712	0.31	778	0.35	842	0.38	898	0.41	944	0.44	986	0.48	1030	0.51
1500	684	0.31	749	0.35	811	0.38	871	0.42	921	0.45	963	0.49	1004	0.53	1048	0.56
1600	723	0.35	785	0.39	844	0.43	898	0.46	943	0.50	983	0.54	1024	0.58	1067	0.61
1700	761	0.40	819	0.44	875	0.48	924	0.52	965	0.56	1004	0.60	1045	0.63	1089	0.66
1800	798	0.45	853	0.49	905	0.54	950	0.58	990	0.62	1028	0.66	1069	0.69	1112	0.72
1900	834	0.51	885	0.55	934	0.60	977	0.64	1015	0.68	1054	0.72	1095	0.75	1137	0.79
2000	869	0.57	917	0.62	962	0.67	1004	0.71	1042	0.75	1081	0.78	1121	0.82	1162	0.86

Air Volume cfm	External Static - in. w.g.															
	0.90		1.00		1.10		1.20		1.30		1.40		1.50		1.60	
	RPM	BHP	RPM	BHP	RPM	BHP	RPM	BHP	RPM	BHP	RPM	BHP	RPM	BHP	RPM	BHP
1200	1043	0.44	1090	0.47	1135	0.50	1179	0.53	1220	0.57	1259	0.60	1297	0.64	1333	0.67
1300	1058	0.49	1104	0.51	1148	0.55	1190	0.58	1231	0.62	1269	0.65	1306	0.69	1342	0.72
1400	1074	0.53	1119	0.56	1162	0.59	1203	0.63	1242	0.67	1280	0.71	1317	0.74	1352	0.78
1500	1092	0.58	1136	0.61	1177	0.65	1217	0.69	1255	0.73	1292	0.76	1328	0.80	1364	0.84
1600	1112	0.63	1154	0.67	1193	0.71	1232	0.75	1269	0.79	1306	0.83	1341	0.87	1377	0.91
1700	1132	0.69	1173	0.73	1211	0.77	1248	0.81	1285	0.86	1321	0.90	1356	0.94	1391	0.98
1800	1154	0.76	1194	0.80	1230	0.85	1266	0.89	1302	0.93	1338	0.98	1373	1.02	1408	1.06
1900	1178	0.83	1215	0.88	1250	0.93	1286	0.98	1321	1.02	1356	1.06	1391	1.10	1426	1.14
2000	1201	0.91	1237	0.97	1271	1.02	1307	1.07	1342	1.11	1376	1.15	1411	1.19	1446	1.23

HORIZONTAL

Air Volume cfm	External Static - in. w.g.															
	0.10		0.20		0.30		0.40		0.50		0.60		0.70		0.80	
	RPM	BHP	RPM	BHP	RPM	BHP	RPM	BHP	RPM	BHP	RPM	BHP	RPM	BHP	RPM	BHP
1200	540	0.18	606	0.22	673	0.26	748	0.29	816	0.30	870	0.33	914	0.37	961	0.40
1300	568	0.21	634	0.26	699	0.29	771	0.32	835	0.34	886	0.37	929	0.41	975	0.44
1400	599	0.25	664	0.29	728	0.33	795	0.35	855	0.38	903	0.41	946	0.45	991	0.49
1500	632	0.29	696	0.33	758	0.36	821	0.39	877	0.42	922	0.46	963	0.50	1008	0.54
1600	667	0.33	729	0.36	789	0.40	848	0.43	898	0.46	941	0.51	982	0.55	1026	0.59
1700	702	0.36	761	0.40	819	0.44	873	0.48	920	0.52	960	0.56	1001	0.61	1044	0.64
1800	737	0.41	794	0.45	848	0.49	898	0.53	941	0.58	981	0.62	1021	0.66	1064	0.70
1900	771	0.46	825	0.50	877	0.54	923	0.59	964	0.64	1002	0.68	1043	0.72	1085	0.76
2000	805	0.51	857	0.56	905	0.61	948	0.66	987	0.71	1025	0.75	1065	0.79	1107	0.82

Air Volume cfm	External Static - in. w.g.															
	0.90		1.00		1.10		1.20		1.30		1.40		1.50		1.60	
	RPM	BHP	RPM	BHP	RPM	BHP	RPM	BHP	RPM	BHP	RPM	BHP	RPM	BHP	RPM	BHP
1200	1010	0.43	1061	0.46	1110	0.50	1156	0.53	1199	0.57	1239	0.61	1276	0.64	1312	0.68
1300	1024	0.47	1073	0.50	1120	0.54	1165	0.58	1207	0.62	1246	0.65	1284	0.69	1320	0.73
1400	1038	0.52	1086	0.55	1131	0.59	1175	0.62	1216	0.66	1255	0.70	1292	0.74	1328	0.78
1500	1054	0.57	1100	0.60	1144	0.64	1186	0.68	1226	0.72	1264	0.75	1301	0.79	1336	0.83
1600	1071	0.62	1116	0.65	1158	0.69	1198	0.73	1237	0.77	1274	0.81	1310	0.85	1345	0.89
1700	1089	0.67	1132	0.71	1172	0.75	1211	0.79	1249	0.83	1285	0.87	1321	0.91	1355	0.95
1800	1108	0.73	1149	0.77	1188	0.81	1225	0.85	1262	0.90	1298	0.94	1332	0.98	1366	1.01
1900	1128	0.79	1167	0.84	1204	0.88	1241	0.92	1276	0.97	1311	1.01	1345	1.05	1379	1.09
2000	1148	0.86	1186	0.91	1221	0.96	1257	1.00	1292	1.05	1326	1.09	1359	1.13	1393	1.17

BLOWER DATA - BELT DRIVE - KGA060

BLOWER TABLE INCLUDES RESISTANCE FOR BASE UNIT ONLY WITH DRY INDOOR COIL AND AIR FILTERS IN PLACE.

FOR ALL UNITS ADD:

1 - Any factory installed options air resistance (heat section, economizer, wet coil, etc.).

2 - Any field installed accessories air resistance (duct resistance, diffuser, etc.).

See page 27 for blower motors and drives and wet coil and options/accessory air resistance data.

DOWNFLOW

Air Volume cfm	External Static - in. w.g.															
	0.10		0.20		0.30		0.40		0.50		0.60		0.70		0.80	
	RPM	BHP	RPM	BHP	RPM	BHP	RPM	BHP	RPM	BHP	RPM	BHP	RPM	BHP	RPM	BHP
1600	745	0.36	805	0.40	862	0.44	913	0.48	956	0.52	996	0.55	1037	0.59	1081	0.62
1700	783	0.41	840	0.45	893	0.49	940	0.53	980	0.57	1019	0.61	1061	0.64	1104	0.67
1800	820	0.47	873	0.51	923	0.55	967	0.60	1006	0.63	1045	0.67	1086	0.70	1129	0.73
1900	856	0.52	906	0.57	953	0.62	994	0.66	1032	0.70	1071	0.73	1112	0.76	1154	0.80
2000	891	0.59	937	0.64	982	0.69	1022	0.73	1060	0.76	1099	0.80	1140	0.84	1180	0.88
2100	924	0.66	968	0.71	1011	0.75	1051	0.79	1089	0.83	1128	0.87	1167	0.92	1206	0.97
2200	956	0.74	999	0.78	1041	0.83	1080	0.87	1119	0.91	1157	0.96	1196	1.02	1233	1.08
2300	990	0.81	1032	0.86	1072	0.91	1111	0.95	1149	1.00	1187	1.06	1225	1.13	1261	1.19
2400	1025	0.90	1066	0.95	1105	1.00	1143	1.05	1181	1.11	1218	1.17	1255	1.24	1290	1.30

Air Volume cfm	External Static - in. w.g.															
	0.90		1.00		1.10		1.20		1.30		1.40		1.50		1.60	
	RPM	BHP	RPM	BHP	RPM	BHP	RPM	BHP	RPM	BHP	RPM	BHP	RPM	BHP	RPM	BHP
1600	1125	0.64	1167	0.68	1206	0.72	1244	0.76	1281	0.80	1317	0.84	1353	0.88	1388	0.92
1700	1147	0.70	1187	0.75	1224	0.79	1261	0.83	1298	0.87	1333	0.91	1369	0.95	1404	0.99
1800	1170	0.77	1208	0.82	1244	0.87	1280	0.91	1316	0.95	1351	0.99	1386	1.03	1422	1.07
1900	1194	0.85	1230	0.90	1265	0.95	1301	1.00	1336	1.04	1371	1.08	1406	1.12	1441	1.16
2000	1218	0.94	1253	1.00	1287	1.05	1323	1.09	1358	1.14	1392	1.17	1427	1.21	1463	1.25
2100	1243	1.03	1277	1.09	1311	1.15	1346	1.19	1381	1.23	1415	1.27	1450	1.31	1486	1.34
2200	1268	1.14	1302	1.20	1336	1.25	1371	1.29	1405	1.33	1439	1.37	1474	1.40	1511	1.44
2300	1295	1.25	1328	1.30	1362	1.35	1397	1.39	1431	1.43	1465	1.47	1500	1.50	1537	1.54
2400	1324	1.36	1356	1.41	1390	1.46	1424	1.50	1458	1.53	1492	1.57	1527	1.61	1563	1.64

HORIZONTAL

Air Volume cfm	External Static - in. w.g.															
	0.10		0.20		0.30		0.40		0.50		0.60		0.70		0.80	
	RPM	BHP	RPM	BHP	RPM	BHP	RPM	BHP	RPM	BHP	RPM	BHP	RPM	BHP	RPM	BHP
1600	690	0.33	751	0.37	810	0.40	865	0.44	912	0.48	955	0.52	997	0.56	1041	0.60
1700	725	0.38	784	0.41	839	0.45	891	0.49	935	0.53	975	0.58	1017	0.62	1060	0.65
1800	761	0.42	816	0.46	868	0.50	916	0.55	957	0.59	997	0.64	1038	0.68	1081	0.71
1900	795	0.48	848	0.52	897	0.56	942	0.61	981	0.66	1020	0.70	1060	0.74	1103	0.77
2000	830	0.53	879	0.58	926	0.63	968	0.68	1006	0.73	1044	0.77	1084	0.80	1126	0.84
2100	863	0.60	910	0.65	954	0.70	994	0.75	1032	0.80	1070	0.83	1110	0.87	1150	0.91
2200	895	0.67	939	0.73	982	0.78	1021	0.83	1058	0.87	1096	0.91	1135	0.95	1174	1.00
2300	926	0.75	969	0.81	1009	0.86	1048	0.90	1085	0.94	1122	0.99	1160	1.04	1197	1.09
2400	957	0.84	998	0.89	1038	0.94	1076	0.98	1112	1.03	1149	1.08	1185	1.14	1221	1.20

Air Volume cfm	External Static - in. w.g.															
	0.90		1.00		1.10		1.20		1.30		1.40		1.50		1.60	
	RPM	BHP	RPM	BHP	RPM	BHP	RPM	BHP	RPM	BHP	RPM	BHP	RPM	BHP	RPM	BHP
1600	1086	0.63	1129	0.66	1171	0.70	1211	0.74	1249	0.78	1286	0.82	1321	0.86	1356	0.90
1700	1104	0.68	1147	0.72	1186	0.76	1225	0.80	1262	0.84	1298	0.88	1333	0.92	1367	0.96
1800	1124	0.74	1165	0.79	1202	0.83	1240	0.87	1276	0.91	1311	0.95	1345	0.99	1380	1.03
1900	1145	0.81	1183	0.85	1220	0.90	1256	0.94	1291	0.99	1326	1.03	1360	1.07	1393	1.10
2000	1167	0.88	1203	0.93	1237	0.98	1273	1.03	1307	1.07	1341	1.11	1375	1.15	1408	1.18
2100	1188	0.96	1222	1.02	1256	1.07	1291	1.12	1324	1.16	1358	1.20	1391	1.23	1424	1.27
2200	1210	1.05	1243	1.11	1275	1.17	1309	1.21	1343	1.25	1376	1.29	1409	1.33	1442	1.36
2300	1232	1.16	1263	1.22	1295	1.27	1329	1.31	1362	1.35	1395	1.39	1428	1.42	1462	1.45
2400	1254	1.26	1284	1.32	1317	1.37	1350	1.41	1383	1.45	1415	1.48	1448	1.52	1483	1.55

BLOWER DATA - BELT DRIVE - KGA072 - DOWNFLOW

BLOWER TABLE INCLUDES RESISTANCE FOR BASE UNIT ONLY WITH DRY INDOOR COIL AND AIR FILTERS IN PLACE.

FOR ALL UNITS ADD:

1 - Any factory installed options air resistance (heat section, economizer, wet coil, etc.).

2 - Any field installed accessories air resistance (duct resistance, diffuser, etc.).

See page 27 for blower motors and drives and wet coil and options/accessory air resistance data.

Air Volume cfm	External Static - in. w.g.															
	0.10		0.20		0.30		0.40		0.50		0.60		0.70		0.80	
	RPM	BHP	RPM	BHP	RPM	BHP	RPM	BHP	RPM	BHP	RPM	BHP	RPM	BHP	RPM	BHP
1900	857	0.41	892	0.45	927	0.50	962	0.55	999	0.60	1036	0.65	1074	0.69	1112	0.73
2000	879	0.47	913	0.52	948	0.56	984	0.61	1020	0.67	1058	0.72	1096	0.76	1134	0.80
2100	900	0.53	935	0.58	970	0.63	1007	0.69	1044	0.74	1081	0.79	1119	0.84	1157	0.88
2200	922	0.60	958	0.65	994	0.71	1031	0.76	1068	0.82	1106	0.87	1143	0.91	1180	0.95
2300	947	0.67	983	0.73	1020	0.79	1057	0.85	1094	0.90	1131	0.95	1168	1.00	1205	1.03
2400	974	0.76	1010	0.82	1047	0.88	1084	0.94	1120	0.99	1157	1.04	1193	1.08	1230	1.12
2500	1002	0.85	1039	0.91	1075	0.97	1112	1.03	1148	1.08	1184	1.13	1220	1.17	1257	1.21
2600	1032	0.95	1068	1.01	1105	1.07	1141	1.13	1177	1.17	1213	1.22	1248	1.26	1284	1.31
2700	1062	1.05	1099	1.11	1136	1.17	1172	1.22	1207	1.27	1242	1.32	1277	1.37	1312	1.43
2800	1094	1.16	1131	1.22	1167	1.27	1202	1.32	1237	1.38	1271	1.43	1305	1.49	1339	1.56
2900	1127	1.26	1163	1.32	1198	1.38	1233	1.44	1267	1.50	1300	1.56	1334	1.64	1367	1.71

Air Volume cfm	External Static - in. w.g.															
	0.90		1.00		1.10		1.20		1.30		1.40		1.50		1.60	
	RPM	BHP	RPM	BHP	RPM	BHP	RPM	BHP	RPM	BHP	RPM	BHP	RPM	BHP	RPM	BHP
1900	1150	0.77	1188	0.81	1227	0.85	1267	0.88	1303	0.92	1333	0.97	1360	1.02	1392	1.06
2000	1172	0.84	1210	0.88	1248	0.92	1286	0.96	1321	1.00	1350	1.05	1377	1.10	1409	1.14
2100	1195	0.91	1233	0.95	1269	1.00	1306	1.04	1339	1.09	1367	1.14	1395	1.19	1426	1.23
2200	1218	0.99	1255	1.03	1290	1.09	1324	1.14	1356	1.19	1385	1.24	1413	1.28	1444	1.32
2300	1242	1.07	1277	1.13	1310	1.20	1343	1.26	1374	1.30	1403	1.34	1432	1.38	1464	1.42
2400	1267	1.16	1300	1.23	1332	1.31	1364	1.37	1394	1.41	1423	1.45	1453	1.48	1484	1.53
2500	1292	1.26	1324	1.34	1355	1.42	1387	1.48	1417	1.52	1445	1.56	1475	1.59	1506	1.64
2600	1318	1.38	1350	1.46	1380	1.55	1411	1.60	1440	1.64	1469	1.68	1498	1.71	1529	1.76
2700	1345	1.51	1376	1.60	1406	1.68	1436	1.73	1465	1.77	1493	1.80	1523	1.84	1553	1.88
2800	1372	1.65	1403	1.74	1433	1.82	1462	1.86	1490	1.90	1519	1.93	1548	1.97	1578	2.01
2900	1399	1.80	1430	1.89	1460	1.96	1489	2.00	1516	2.03	1544	2.06	1573	2.10	1603	2.14

BLOWER DATA - BELT DRIVE - KGA072 - HORIZONTAL

BLOWER TABLE INCLUDES RESISTANCE FOR BASE UNIT ONLY WITH DRY INDOOR COIL AND AIR FILTERS IN PLACE.

FOR ALL UNITS ADD:

1 - Any factory installed options air resistance (heat section, economizer, wet coil, etc.).

2 - Any field installed accessories air resistance (duct resistance, diffuser, etc.).

See page 27 for blower motors and drives and wet coil and options/accessory air resistance data.

Air Volume cfm	External Static - in. w.g.															
	0.10		0.20		0.30		0.40		0.50		0.60		0.70		0.80	
	RPM	BHP	RPM	BHP	RPM	BHP	RPM	BHP	RPM	BHP	RPM	BHP	RPM	BHP	RPM	BHP
1900	796	0.38	837	0.43	878	0.48	918	0.53	958	0.58	997	0.62	1036	0.67	1074	0.71
2000	833	0.43	870	0.48	907	0.54	943	0.59	980	0.64	1018	0.69	1055	0.73	1093	0.77
2100	864	0.50	897	0.55	931	0.60	966	0.65	1002	0.71	1038	0.76	1075	0.80	1113	0.83
2200	887	0.57	920	0.62	953	0.67	988	0.73	1024	0.78	1060	0.83	1097	0.87	1135	0.90
2300	909	0.64	942	0.70	976	0.75	1011	0.81	1046	0.86	1083	0.91	1120	0.95	1157	0.98
2400	931	0.72	965	0.78	999	0.83	1035	0.89	1071	0.94	1108	0.99	1144	1.03	1181	1.07
2500	955	0.80	989	0.86	1024	0.92	1061	0.98	1097	1.03	1133	1.08	1170	1.11	1205	1.15
2600	981	0.90	1016	0.96	1052	1.01	1088	1.07	1124	1.12	1160	1.16	1195	1.20	1230	1.25
2700	1009	0.99	1044	1.05	1080	1.11	1116	1.16	1152	1.21	1187	1.26	1221	1.30	1254	1.35
2800	1038	1.10	1073	1.16	1109	1.21	1145	1.26	1180	1.31	1214	1.36	1247	1.40	1279	1.46
2900	1068	1.20	1104	1.26	1139	1.31	1174	1.36	1208	1.41	1240	1.47	1273	1.52	1304	1.58

Air Volume cfm	External Static - in. w.g.															
	0.90		1.00		1.10		1.20		1.30		1.40		1.50		1.60	
	RPM	BHP	RPM	BHP	RPM	BHP	RPM	BHP	RPM	BHP	RPM	BHP	RPM	BHP	RPM	BHP
1900	1112	0.74	1151	0.77	1190	0.81	1228	0.84	1265	0.88	1301	0.92	1335	0.97	1367	1.01
2000	1131	0.80	1170	0.83	1208	0.87	1245	0.91	1281	0.96	1316	1.00	1349	1.04	1380	1.09
2100	1151	0.87	1189	0.90	1227	0.94	1263	0.99	1298	1.04	1331	1.08	1363	1.13	1394	1.17
2200	1173	0.94	1210	0.98	1246	1.02	1281	1.07	1315	1.12	1347	1.17	1379	1.22	1409	1.26
2300	1195	1.02	1231	1.06	1266	1.11	1300	1.16	1333	1.22	1364	1.27	1395	1.32	1424	1.36
2400	1217	1.10	1252	1.15	1286	1.20	1319	1.26	1351	1.32	1382	1.38	1411	1.43	1440	1.48
2500	1240	1.20	1274	1.25	1307	1.31	1339	1.37	1370	1.43	1400	1.49	1428	1.55	1457	1.59
2600	1264	1.30	1297	1.35	1329	1.42	1360	1.49	1389	1.55	1418	1.61	1446	1.67	1475	1.72
2700	1287	1.40	1319	1.47	1350	1.54	1380	1.61	1409	1.68	1437	1.74	1465	1.79	1493	1.84
2800	1311	1.52	1342	1.59	1373	1.66	1402	1.74	1430	1.8	1457	1.87	1485	1.92	1513	1.97
2900	1335	1.65	1366	1.72	1395	1.79	1424	1.87	1451	1.94	1478	2.00	1505	2.05	1533	2.09

BLOWER DATA - BELT DRIVE - KGA090 - DOWNFLOW

BLOWER TABLE INCLUDES RESISTANCE FOR BASE UNIT ONLY WITH DRY INDOOR COIL AND AIR FILTERS IN PLACE.

FOR ALL UNITS ADD:

1 - Any factory installed options air resistance (heat section, economizer, wet coil, etc.).

2 - Any field installed accessories air resistance (duct resistance, diffuser, etc.).

See page 27 for blower motors and drives and wet coil and options/accessory air resistance data.

Air Volume cfm	External Static - in. w.g.																			
	0.10		0.20		0.30		0.40		0.50		0.60		0.70		0.80		0.90		1.00	
	RPM	BHP	RPM	BHP	RPM	BHP	RPM	BHP	RPM	BHP	RPM	BHP	RPM	BHP	RPM	BHP	RPM	BHP	RPM	BHP
2400	621	0.71	652	0.76	684	0.81	716	0.86	746	0.92	776	0.97	805	1.02	830	1.08	855	1.14	879	1.19
2500	642	0.77	673	0.82	704	0.87	734	0.93	764	0.98	793	1.04	820	1.09	845	1.15	868	1.21	892	1.27
2600	665	0.82	694	0.88	724	0.93	753	0.99	782	1.05	810	1.11	835	1.17	859	1.23	883	1.29	907	1.34
2700	688	0.89	716	0.94	744	1.00	773	1.06	800	1.13	827	1.19	851	1.25	875	1.31	898	1.37	922	1.42
2800	710	0.95	738	1.02	765	1.08	792	1.15	818	1.21	844	1.28	868	1.34	891	1.40	914	1.45	938	1.51
2900	733	1.03	759	1.10	785	1.17	811	1.24	836	1.30	861	1.37	885	1.43	908	1.49	931	1.54	954	1.59
3000	754	1.12	779	1.19	805	1.26	830	1.33	855	1.40	879	1.46	902	1.52	925	1.58	948	1.63	970	1.69
3100	775	1.22	800	1.29	824	1.36	849	1.43	873	1.50	897	1.56	920	1.62	942	1.67	964	1.73	987	1.78
3200	796	1.32	820	1.39	844	1.47	868	1.53	892	1.60	915	1.66	937	1.72	959	1.77	981	1.83	1002	1.88
3300	816	1.43	840	1.50	863	1.57	887	1.64	910	1.70	933	1.76	955	1.82	976	1.88	997	1.93	1018	1.99
3400	837	1.54	860	1.61	883	1.68	906	1.75	929	1.81	951	1.87	972	1.93	993	1.98	1013	2.05	1033	2.11
3500	858	1.66	881	1.73	903	1.79	926	1.86	948	1.92	969	1.98	990	2.04	1009	2.10	1029	2.17	1048	2.24
3600	879	1.77	901	1.84	923	1.91	945	1.97	966	2.04	987	2.10	1006	2.16	1025	2.23	1044	2.30	1062	2.38

Air Volume cfm	External Static - in. w.g.																			
	0.90		1.00		1.30		1.40		1.50		1.60		1.70		1.80		1.90		2.00	
	RPM	BHP	RPM	BHP	RPM	BHP	RPM	BHP	RPM	BHP	RPM	BHP	RPM	BHP	RPM	BHP	RPM	BHP	RPM	BHP
2400	904	1.25	929	1.29	956	1.34	982	1.39	1008	1.43	1032	1.49	1056	1.55	1078	1.62	1099	1.68	1121	1.75
2500	917	1.32	942	1.37	968	1.41	994	1.46	1020	1.51	1044	1.57	1066	1.64	1088	1.70	1108	1.77	1130	1.84
2600	931	1.39	957	1.44	982	1.49	1008	1.54	1032	1.60	1055	1.66	1077	1.73	1098	1.80	1118	1.87	1139	1.94
2700	946	1.47	971	1.52	996	1.57	1021	1.63	1045	1.69	1067	1.76	1088	1.83	1108	1.91	1127	1.98	1148	2.05
2800	962	1.56	986	1.61	1011	1.66	1034	1.72	1057	1.79	1079	1.86	1099	1.94	1118	2.02	1137	2.09	1158	2.16
2900	978	1.65	1001	1.70	1025	1.75	1048	1.82	1069	1.89	1090	1.98	1109	2.06	1128	2.14	1147	2.22	1167	2.28
3000	993	1.74	1016	1.79	1039	1.86	1061	1.93	1081	2.01	1101	2.10	1120	2.18	1138	2.27	1157	2.34	1177	2.41
3100	1009	1.84	1031	1.90	1052	1.97	1073	2.05	1093	2.13	1112	2.22	1130	2.31	1148	2.40	1167	2.47	1187	2.53
3200	1024	1.94	1045	2.01	1065	2.09	1085	2.17	1104	2.26	1123	2.36	1141	2.45	1159	2.53	1178	2.60	1198	2.66
3300	1038	2.06	1058	2.13	1078	2.22	1097	2.31	1116	2.40	1134	2.49	1152	2.58	1170	2.66	1189	2.73	1209	2.79
3400	1053	2.19	1072	2.27	1091	2.35	1109	2.45	1127	2.54	1145	2.63	1163	2.72	1181	2.79	1200	2.86	1220	2.92
3500	1067	2.32	1085	2.41	1103	2.50	1121	2.59	1138	2.69	1156	2.78	1174	2.85	1192	2.93	1212	2.99	1231	3.05
3600	1081	2.46	1098	2.55	1116	2.64	1133	2.74	1151	2.83	1168	2.91	1186	2.99	1205	3.06	1224	3.12	1243	3.17

BLOWER DATA - BELT DRIVE - KGA090 - HORIZONTAL

BLOWER TABLE INCLUDES RESISTANCE FOR BASE UNIT ONLY WITH DRY INDOOR COIL AND AIR FILTERS IN PLACE.

FOR ALL UNITS ADD:

1 - Any factory installed options air resistance (heat section, economizer, wet coil, etc.).

2 - Any field installed accessories air resistance (duct resistance, diffuser, etc.).

See page 27 for blower motors and drives and wet coil and options/accessory air resistance data.

Air Volume cfm	External Static - in. w.g.																			
	0.10		0.20		0.30		0.40		0.50		0.60		0.70		0.80		0.90		1.00	
	RPM	BHP	RPM	BHP	RPM	BHP	RPM	BHP	RPM	BHP	RPM	BHP	RPM	BHP	RPM	BHP	RPM	BHP	RPM	BHP
2400	572	0.75	602	0.78	633	0.81	664	0.85	695	0.88	725	0.92	755	0.97	784	1.01	811	1.06	836	1.11
2500	591	0.80	620	0.83	650	0.87	680	0.90	711	0.94	740	0.98	769	1.03	797	1.08	823	1.13	847	1.18
2600	610	0.86	639	0.89	668	0.92	697	0.96	727	1.00	755	1.05	783	1.09	810	1.14	835	1.20	859	1.25
2700	630	0.91	658	0.95	686	0.98	715	1.02	743	1.07	771	1.11	798	1.16	824	1.22	848	1.27	872	1.32
2800	650	0.97	677	1.01	705	1.05	732	1.09	760	1.14	787	1.19	813	1.24	838	1.30	861	1.35	885	1.40
2900	670	1.03	697	1.07	724	1.11	750	1.16	777	1.21	803	1.27	828	1.32	852	1.38	876	1.44	898	1.49
3000	691	1.09	717	1.14	743	1.18	769	1.24	794	1.29	819	1.35	844	1.42	868	1.47	890	1.53	913	1.58
3100	712	1.16	737	1.21	762	1.27	787	1.32	812	1.39	836	1.45	860	1.51	883	1.57	906	1.63	928	1.68
3200	732	1.24	756	1.30	781	1.36	805	1.42	829	1.48	853	1.55	876	1.61	899	1.67	921	1.73	943	1.78
3300	752	1.33	776	1.39	799	1.46	823	1.52	847	1.59	870	1.65	893	1.71	916	1.77	937	1.83	959	1.88
3400	772	1.43	795	1.50	818	1.56	842	1.63	865	1.69	888	1.76	910	1.82	932	1.88	953	1.93	974	1.99
3500	792	1.54	815	1.61	838	1.67	861	1.74	883	1.80	906	1.87	928	1.93	949	1.98	970	2.04	990	2.10
3600	812	1.65	834	1.72	857	1.79	880	1.85	902	1.92	924	1.98	945	2.04	966	2.10	986	2.16	1005	2.22

Air Volume cfm	External Static - in. w.g.																			
	0.90		1.00		1.30		1.40		1.50		1.60		1.70		1.80		1.90		2.00	
	RPM	BHP	RPM	BHP	RPM	BHP	RPM	BHP	RPM	BHP	RPM	BHP	RPM	BHP	RPM	BHP	RPM	BHP	RPM	BHP
2400	861	1.16	886	1.21	911	1.26	937	1.30	963	1.35	988	1.41	1012	1.47	1034	1.53	1055	1.59	1076	1.65
2500	872	1.23	896	1.27	921	1.32	947	1.37	972	1.43	997	1.48	1019	1.55	1041	1.61	1061	1.68	1081	1.74
2600	883	1.30	908	1.35	933	1.40	958	1.45	982	1.50	1006	1.57	1027	1.63	1048	1.70	1068	1.77	1087	1.83
2700	895	1.37	920	1.42	944	1.47	969	1.53	992	1.59	1015	1.65	1036	1.72	1056	1.79	1075	1.86	1094	1.92
2800	908	1.45	932	1.50	956	1.56	980	1.62	1003	1.68	1025	1.75	1045	1.82	1064	1.89	1083	1.96	1102	2.02
2900	922	1.54	945	1.59	969	1.65	992	1.71	1014	1.78	1035	1.85	1055	1.92	1074	2.00	1092	2.07	1111	2.13
3000	936	1.63	959	1.68	982	1.74	1004	1.81	1026	1.88	1046	1.96	1065	2.03	1084	2.11	1102	2.18	1120	2.25
3100	950	1.73	973	1.78	995	1.85	1017	1.91	1037	1.99	1057	2.07	1076	2.15	1094	2.23	1112	2.31	1130	2.38
3200	965	1.83	987	1.89	1008	1.95	1029	2.03	1049	2.11	1068	2.19	1087	2.28	1105	2.36	1123	2.44	1141	2.51
3300	980	1.94	1001	2.00	1022	2.07	1042	2.15	1061	2.23	1080	2.32	1098	2.41	1116	2.50	1134	2.58	1152	2.65
3400	995	2.05	1015	2.12	1035	2.19	1054	2.28	1073	2.37	1092	2.46	1110	2.55	1128	2.64	1145	2.72	1163	2.79
3500	1010	2.17	1029	2.24	1048	2.32	1067	2.41	1086	2.51	1104	2.60	1122	2.70	1139	2.78	1157	2.86	1174	2.93
3600	1024	2.30	1043	2.38	1062	2.46	1080	2.55	1098	2.65	1116	2.75	1133	2.84	1151	2.93	1168	3.01	1186	3.08

BLOWER DATA

BELT DRIVE KIT SPECIFICATIONS - 036-072

Model No.	Motor HP		No. of Speeds	Drive Kits and RPM Range							
	Nominal	Maximum		A01	A02	A03	A04	A05	A06	A07	A08
036	0.75	0.86	1	673-1010	---	---	---	897-1346	---	---	---
	1	1.15	1	673-1010	---	---	---	897-1346	---	---	---
	1.5	1.7	1	673-1010	---	---	---	897-1346	---	---	---
	2	2.3	1	673-1010	---	---	---	897-1346	---	---	---
048	0.75	0.86	1	---	745-1117	---	---	---	1071-1429	---	---
	1	1.15	1	---	745-1117	---	---	---	1071-1429	---	---
	1.5	1.7	1	---	745-1117	---	---	---	1071-1429	---	---
	2	2.3	1	---	745-1117	---	---	---	1071-1429	---	---
060	0.75	0.86	1	---	---	833-1250	---	---	---	1212-1548	---
	1	1.15	1	---	---	833-1250	---	---	---	1212-1548	---
	1.5	1.7	1	---	---	833-1250	---	---	---	1212-1548	---
	2	2.3	1	---	---	833-1250	---	---	---	1212-1548	---
072	1	1.5	1	---	---	---	968-1340	---	---	---	1193-1591
	2	2.3	1	---	---	---	968-1340	---	---	---	1193-1591

BELT DRIVE KIT SPECIFICATIONS - 090

Model No.	Motor HP		No. of Speeds	Drive Kits and RPM Range			
	Nominal	Maximum		AA01	AA02	AA03	AA04
090	1	1.15	1	522-784	---	---	---
	2	2.3	1	---	632-875	798-1105	---
	3	3.45	1	---	---	---	921-1228

NOTE - Using total air volume and system static pressure requirements determine from blower performance tables rpm and motor hp required. Maximum usable hp of motors furnished are shown. In Canada, nominal motor hp is also maximum usable motor hp. If motors of comparable hp are used, be sure to keep within the service factor limitations outlined on the motor nameplate.

OPTIONS / ACCESSORIES AIR RESISTANCE FOR 036-072 MODELS - in. w.g.

Air Volume cfm	Wet Indoor Coil			Gas Heat		Economizer	Filters	
	036-048	060	072	Medium Input	High Input		MERV 8	MERV 13
800	0.01	0.01	0.01	0.02	0.02	0.04	0.04	0.05
1000	0.02	0.02	0.01	0.02	0.02	0.04	0.04	0.07
1200	0.03	0.04	0.02	0.02	0.02	0.04	0.04	0.07
1400	0.04	0.05	0.03	0.02	0.03	0.04	0.04	0.07
1600	0.05	0.06	0.04	0.03	0.04	0.04	0.04	0.07
1800	0.06	0.07	0.05	0.03	0.05	0.05	0.05	0.07
2000	0.08	0.09	0.06	0.04	0.06	0.05	0.05	0.08
2200	0.09	0.10	0.07	0.04	0.07	0.05	0.05	0.08
2400	0.10	0.12	0.08	0.05	0.08	0.05	0.05	0.08
2600	0.11	0.13	0.09	0.05	0.09	0.06	0.05	0.08
2800	0.13	0.15	0.10	0.06	0.10	0.06	0.05	0.08
3000	0.14	0.16	0.12	0.07	0.11	0.06	0.05	0.08

OPTIONS / ACCESSORIES AIR RESISTANCE FOR 090 MODELS - in. w.g.

Air Volume cfm	Wet Indoor Coil	Gas Heat High Input	Economizer	Filters	
				MERV 8	MERV 13
2400	0.08	0.03	0.05	0.05	0.08
2600	0.09	0.04	0.06	0.05	0.08
2800	0.10	0.04	0.06	0.05	0.08
3000	0.11	0.04	0.06	0.05	0.08
3200	0.12	0.04	0.06	0.06	0.09
3400	0.14	0.05	0.06	0.06	0.09
3600	0.15	0.05	0.06	0.06	0.10

BLOWER DATA

CEILING DIFFUSERS AIR RESISTANCE (in. w.g.)

Air Volume cfm	RTD9-65S Step-Down Diffuser			FD9-65S Flush Diffuser	RTD11-95S Step-Down Diffuser			FD11-95S Flush Diffuser
	2 Ends Open	1 Side & 2 Ends Open	All Ends & Sides Open		2 Ends Open	1 Side & 2 Ends Open	All Ends & Sides Open	
800	0.15	0.13	0.11	0.11	---	---	---	---
1000	0.19	0.16	0.14	0.14	---	---	---	---
1200	0.25	0.20	0.17	0.17	---	---	---	---
1400	0.33	0.26	0.20	0.20	---	---	---	---
1600	0.43	0.32	0.20	0.24	---	---	---	---
1800	0.56	0.40	0.30	0.30	0.13	0.11	0.09	0.09
2000	0.73	0.50	0.36	0.36	0.15	0.13	0.11	0.10
2200	0.95	0.63	0.44	0.44	0.18	0.15	0.12	0.12
2400	---	---	---	---	0.21	0.18	0.15	0.14
2600	---	---	---	---	0.24	0.21	0.18	0.17
2800	---	---	---	---	0.27	0.24	0.21	0.20
3000	---	---	---	---	0.32	0.29	0.25	0.25
3200	---	---	---	---	0.41	0.37	0.32	0.31
3400	---	---	---	---	0.50	0.45	0.39	0.37
3600	---	---	---	---	0.61	0.54	0.48	0.44

CEILING DIFFUSER AIR THROW DATA

Air Volume - cfm	¹ Effective Throw - ft.	
Model No.	RTD9-65S	FD9-65S
800	10 - 17	14 - 18
1000	10 - 17	15 - 20
1200	11 - 18	16 - 22
1400	12 - 19	17 - 24
1600	12 - 20	18 - 25
1800	13 - 21	20 - 28
2000	14 - 23	21 - 29
2200	16 - 25	22 - 30
Model No.	RTD11-95S	FD11-95S
2600	24 - 29	19 - 24
2800	25 - 30	20 - 28
3000	27 - 33	21 - 29
3200	28 - 35	22 - 29
3400	30 - 37	22 - 30
3600	25 - 33	22 - 24

¹ Effective throw based on terminal velocities of 75 ft. per minute.

ELECTRICAL DATA**3 TON****KGA036 - DIRECT AND BELT DRIVE**

¹ Voltage - 60hz		208/230V - 3 Ph			460V - 3 Ph			575V - 3 Ph		
Compressor	Rated Load Amps	8.7			4			3.6		
	Locked Rotor Amps	70			31			27		
Outdoor Fan Motor	Full Load Amps	1.7			1.1			0.7		
Power Exhaust (1) 0.33 HP	Full Load Amps	2.4			1.3			1		
Service Outlet 115V GFI (amps)		15			15			20		
Indoor Blower Motor	Horsepower	0.5	1	2	0.5	1	2	0.5	1	2
	Type	Direct	Belt	Belt	Direct	Belt	Belt	Direct	Belt	Belt
	Full Load Amps	3.9	4.6	7.5	2	2.1	3.4	2	1.7	2.7
² Maximum Overcurrent Protection	Unit Only	25	25	25	15	15	15	15	15	15
	with (1) 0.33 HP Power Exhaust	25	25	30	15	15	15	15	15	15
³ Minimum Circuit Ampacity	Unit Only	17	18	21	9	9	10	8	7	8
	with (1) 0.33 HP Power Exhaust	19	20	23	10	10	11	9	8	9

ELECTRICAL ACCESSORIES

Disconnect	Standard Access	20W17	20W17	20W17
	Hinged Access	20W23	20W23	20W23

NOTE - All units have a minimum Short Circuit Current Rating (SCCR) of 5000 amps.

¹ Extremes of operating range are plus and minus 10% of line voltage.² HACR type breaker or fuse.³ Refer to National or Canadian Electrical Code manual to determine wire, fuse and disconnect size requirements.**ELECTRICAL DATA****4 TON****KGA048 - DIRECT AND BELT DRIVE**

¹ Voltage - 60hz		208/230V - 3 Ph			460V - 3 Ph			575V - 3 Ph		
Compressor	Rated Load Amps	11			5.5			4.7		
	Locked Rotor Amps	86			37			34		
Outdoor Fan Motor	Full Load Amps	1.7			1.1			0.7		
Power Exhaust (1) 0.33 HP	Full Load Amps	2.4			1.3			1		
Service Outlet 115V GFI (amps)										
Indoor Blower Motor	Horsepower	0.5	1	2	0.5	1	2	0.5	1	2
	Type	Direct	Belt	Belt	Direct	Belt	Belt	Direct	Belt	Belt
	Full Load Amps	3.9	4.6	7.5	2	2.1	3.4	2	1.7	2.7
² Maximum Overcurrent Protection	Unit Only	30	30	30	15	15	15	15	15	15
	with (1) 0.33 HP Power Exhaust	30	30	35	15	15	15	15	15	15
³ Minimum Circuit Ampacity	Unit Only	20	21	23	10	11	13	12	9	10
	with (1) 0.33 HP Power Exhaust	22	23	26	12	12	13	10	10	11

ELECTRICAL ACCESSORIES

Disconnect	Standard Access	20W17	20W17	20W17
	Hinged Access	20W23	20W23	20W23

NOTE - All units have a minimum Short Circuit Current Rating (SCCR) of 5000 amps.

¹ Extremes of operating range are plus and minus 10% of line voltage.² HACR type breaker or fuse.³ Refer to National or Canadian Electrical Code manual to determine wire, fuse and disconnect size requirements.

ELECTRICAL DATA**5 TON****KGA060 - DIRECT AND BELT DRIVE**

¹ Voltage - 60hz		208/230V - 3 Ph			460V - 3 Ph			575V - 3 Ph		
Compressor	Rated Load Amps	13.5			8			5		
	Locked Rotor Amps	109			59			40		
Outdoor Fan Motor	Full Load Amps	2.4			1.3			1		
Power Exhaust (1) 0.33 HP	Full Load Amps	2.4			1.3			1		
Service Outlet 115V GFI (amps)		15			15			20		
Indoor Blower Motor	Horsepower Type	0.75	1	2	0.75	1	2	0.75	1	2
		Direct	Belt	Belt	Direct	Belt	Belt	Direct	Belt	Belt
	Full Load Amps	4.9	4.6	7.5	2.5	2.1	3.4	2.5	1.7	2.7
² Maximum Overcurrent Protection	Unit Only	35	35	40	20	20	20	15	15	15
	with (1) 0.33 HP Power Exhaust	40	35	40	20	20	20	15	15	15
³ Minimum Circuit Ampacity	Unit Only	25	24	27	14	14	15	10	9	10
	with (1) 0.33 HP Power Exhaust	27	27	30	16	15	16	11	10	11

ELECTRICAL ACCESSORIES

Disconnect	Standard Access	20W17			20W17			20W17		
	Hinged Access	20W23			20W23			20W23		

NOTE - All units have a minimum Short Circuit Current Rating (SCCR) of 5000 amps.

¹ Extremes of operating range are plus and minus 10% of line voltage.² HACR type breaker or fuse.³ Refer to National or Canadian Electrical Code manual to determine wire, fuse and disconnect size requirements.**ELECTRICAL DATA****6 TON****KGA072 - BELT DRIVE BLOWER**

¹ Voltage - 60hz		208/230V - 3 Ph		460V - 3 Ph		575V - 3 Ph	
Compressor	Rated Load Amps	19.6		8.2		6.6	
	Locked Rotor Amps	136		66.1		55.3	
Outdoor Fan Motor	Full Load Amps	2.4		1.3		1	
Power Exhaust (1) 0.33 HP	Full Load Amps	2.4		1.3		1	
Service Outlet 115V GFI (amps)		15		15		20	
Indoor Blower Motor	Horsepower Type	1	2	1	2	1	2
		Belt	Belt	Belt	Belt	Belt	Belt
	Full Load Amps	4.6	7.5	2.1	3.4	1.7	2.7
² Maximum Overcurrent Protection	Unit Only	50	50	20	20	15	15
	with (1) 0.33 HP Power Exhaust	50	50	20	20	15	15
³ Minimum Circuit Ampacity	Unit Only	32	35	14	15	11	12
	with (1) 0.33 HP Power Exhaust	34	37	15	17	12	13

ELECTRICAL ACCESSORIES

Disconnect Kit	Standard Access	20W20		20W20		20W20	
	Hinged Access	20W26		20W26		20W26	

NOTE - All units have a minimum Short Circuit Current Rating (SCCR) of 5000 amps.

¹ Extremes of operating range are plus and minus 10% of line voltage.² HACR type breaker or fuse.³ Refer to National or Canadian Electrical Code manual to determine wire, fuse and disconnect size requirements.

ELECTRICAL DATA**7.5 TON****KGA090 - BELT DRIVE BLOWER**

¹ Voltage - 60hz		208/230V - 3 Ph			460V - 3 Ph			575V - 3 Ph		
Compressor 1	Rated Load Amps	25			12.2			9		
	Locked Rotor Amps	164			100			78		
Outdoor Fan Motors (1)	Full Load Amps (total)	2.4			1.3			1		
Power Exhaust (1) 0.33 HP	Full Load Amps (total)	2.4			1.3			1		
Service Outlet 115V GFI		15			15			20		
Indoor Blower Motor	Horsepower	1	2	3	1	2	3	1	2	3
	Type	Belt	Belt	Belt	Belt	Belt	Belt	Belt	Belt	Belt
	Full Load Amps	4.6	7.5	10.6	2.1	3.4	4.8	1.7	2.7	3.9
² Maximum Overcurrent Protection	Unit Only	60	60	60	30	30	30	20	20	25
	with (1) 0.33 HP Power Exhaust	60	60	70	30	30	30	20	20	25
³ Minimum Circuit Ampacity	Unit Only	39	42	45	19	20	22	14	15	17
	with (1) 0.33 HP Power Exhaust	41	44	47	20	22	23	15	16	18

ELECTRICAL ACCESSORIES

Disconnect Kit	Standard Access	20W20	20W20	20W20
	Hinged Access	20W26	20W26	20W26

NOTE - All units have a minimum Short Circuit Current Rating (SCCR) of 5000 amps.

¹ Extremes of operating range are plus and minus 10% of line voltage.² HACR type breaker or fuse.³ Refer to National or Canadian Electrical Code manual to determine wire, fuse and disconnect size requirements.

UNIT CLEARANCES - INCHES (MM)

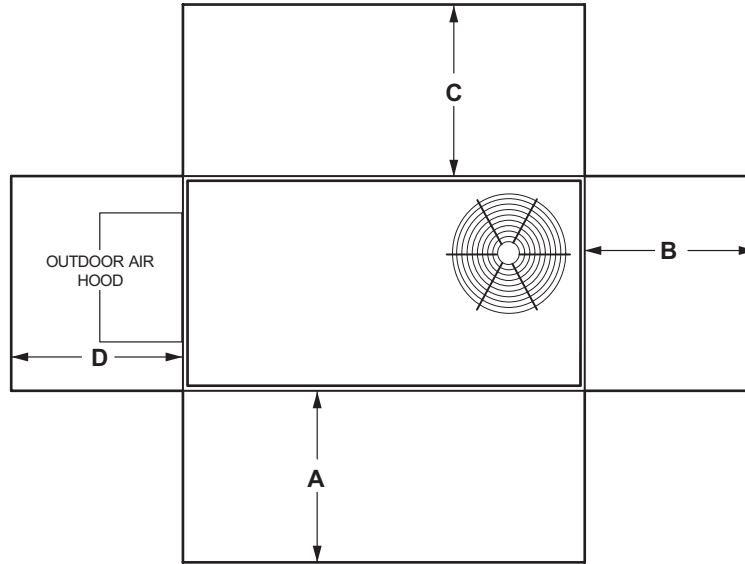

¹ Unit Clearance	A		B		C		D		Top Clearance
	in.	mm	in.	mm	in.	mm	in.	mm	
Service Clearance	48	1219	36	914	36	914	36	914	Unobstructed
Clearance to Combustibles	36	914	1	25	1	25	1	25	
Minimum Operation Clearance	36	914	36	914	36	914	36	914	

NOTE - Entire perimeter of unit base requires support when elevated above the mounting surface.

¹ **Service Clearance** - Required for removal of serviceable parts.

Clearance to Combustibles - Required clearance to combustible material.

Minimum Operation Clearance - Required clearance for proper unit operation.

OUTDOOR SOUND DATA

Unit Model No.	Octave Band Linear Sound Power Levels dBA, re 10 ⁻¹² Watts - Center Frequency - Hz							¹ Sound Rating Number (SRN) (dBA)
	125	250	500	1000	2000	4000	8000	
KGA036 and 048	63	66	70	71	68	62	53	75
KGA060	67	72	77	76	73	68	61	82
KGA072	66	71	74	73	70	65	57	79
KGA090	66	71	73	74	70	65	57	79

Note - The octave sound power data does not include tonal corrections.

¹ Sound Rating Number according to ARI Standard 270-95 (includes pure tone penalty). "SRN" is the overall A-Weighted Sound Power Level, (LWA), dBA (100 Hz to 10,000 Hz).

WEIGHT DATA

Model Number	Net				Shipping			
	Base		Max.		Base		Max.	
	lbs.	kg	lbs.	kg	lbs.	kg	lbs.	kg
KGA036	534	242	634	288	594	269	703	319
KGA048	571	258	682	309	631	286	751	341
KGA060	601	273	712	323	661	300	781	354
KGA072	649	294	813	369	690	313	854	387
KGA090	783	355	883	401	843	382	953	432

Base Unit - The unit with standard heat exchanger NO OPTIONS.

Max. Unit - The unit with ALL OPTIONS Installed. (High Input Heat Exchanger, Economizer, etc.)

OPTIONS / ACCESSORIES

	Shipping Weights		
	lbs.	kg	
ECONOMIZER / OUTDOOR AIR / EXHAUST			
Economizer			
Economizer - Includes Barometric Relief Dampers and Exhaust Hood	131	59	
Outdoor Air Dampers			
Motorized	40	18	
Manual	30	14	
Power Exhaust			
Standard Static	35	16	
GAS HEAT			
Medium Heat (adder over standard heat)	8	4	
High Heat (adder over standard heat)	19	9	
ROOF CURBS			
Hybrid Roof Curbs, Downflow			
8 in. height	50	23	
14 in. height	70	32	
18 in. height	80	36	
24 in. height	100	45	
Hybrid Curbs, Full Perimeter, Downflow			
8 in. height	57	26	
14 in. height	60	27	
18 in. height	91	41	
24 in. height	114	52	
Adjustable Pitch Curb, Downflow			
14 in. height	113	51	
CEILING DIFFUSERS			
Step-Down	RTD9-65S	80	36
	RTD11-95S	118	54
Flush	FD9-65S	80	36
	FD11-95S	118	54
Transitions (Supply and Return)	T1TRAN10AN1	22	10
	T1TRAN20N-1	21	10

DIMENSIONS - UNIT - INCHES (MM)

Model No.	CORNER WEIGHTS								CENTER OF GRAVITY															
	AA		BB		CC		DD		EE		FF		FF											
	Base	Max.	Base	Max.	Base	Max.	Base	Max.	Base	Max.	Base	Max.	Base	Max.										
	lbs.	kg	lbs.	kg	lbs.	kg	lbs.	kg	lbs.	kg	in.	mm	in.	mm	in.	mm								
036	92	42	114	52	112	51	129	59	181	82	208	94	149	68	184	83	38-1/2	978	40	1016	18	457	18	457
048	99	45	123	56	120	55	139	63	193	88	223	102	159	72	197	90	38-1/2	978	40	1016	18	457	18	457
060	104	47	128	58	126	57	145	66	203	92	233	106	167	76	206	94	38-1/2	978	40	1016	18	457	18	457
072	130	59	162	74	147	67	167	76	198	90	226	103	175	79	257	117	40	1016	44	1118	20	508	20	508
090	168	76	195	88	183	83	212	96	227	103	263	119	203	95	241	109	47	1194	47	1194	21	533	21	533

Base Unit - The unit with NO INTERNAL OPTIONS.

Max. Unit - The unit with ALL INTERNAL OPTIONS Installed. (Economizer, Standard Static Power Exhaust Fans, Controls, etc.). Does not include accessories external to unit or high static power exhaust.

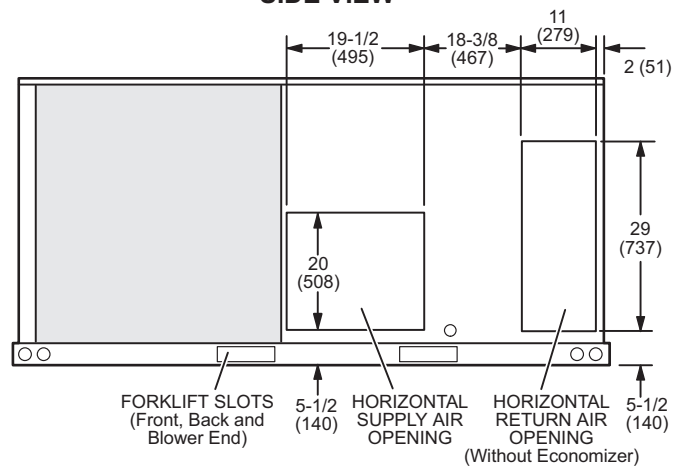
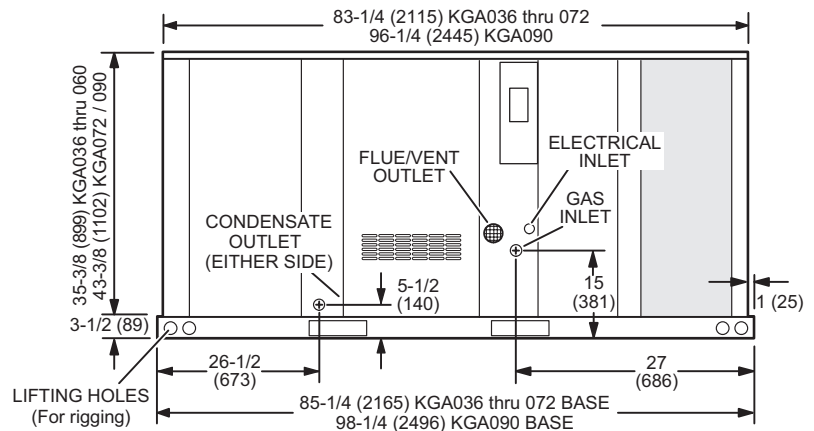
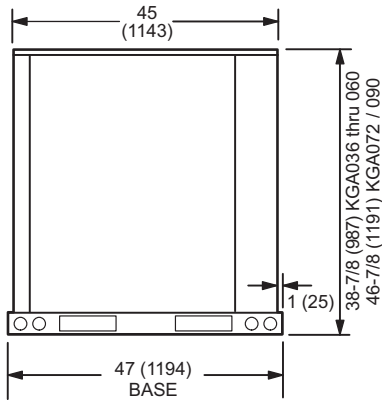
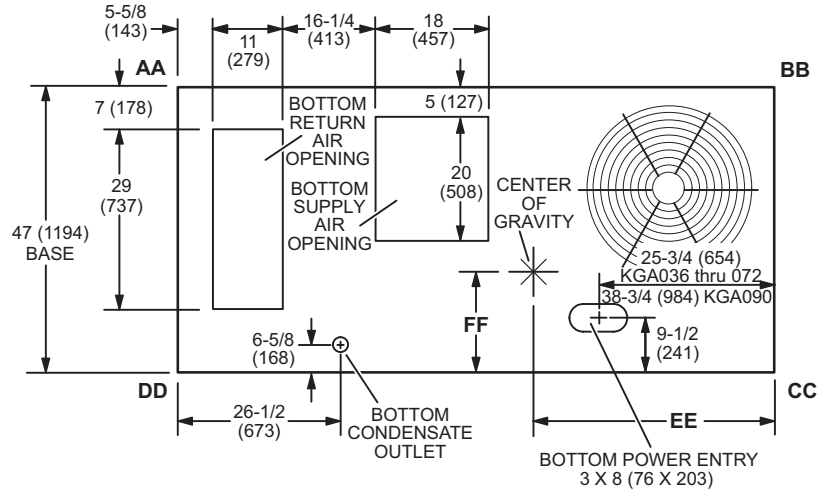

DIMENSIONS - ACCESSORIES - INCHES (MM)

OUTDOOR AIR HOOD DETAIL FOR OPTIONAL ECONOMIZER AND BAROMETRIC RELIEF DAMPERS (Downflow Applications)

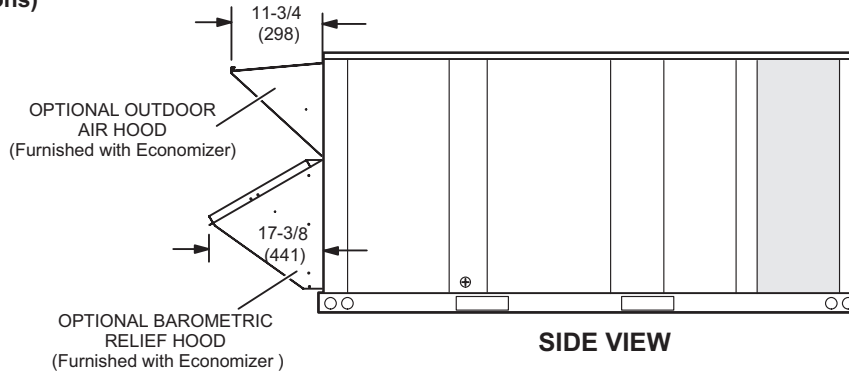

OUTDOOR AIR HOOD FOR ECONOMIZER (Furnished)

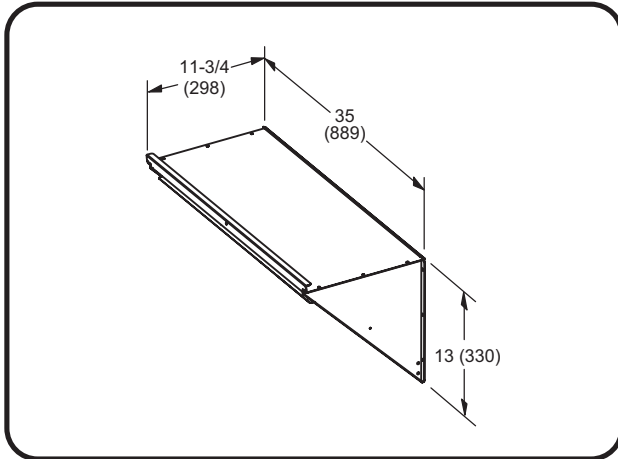

BAROMETRIC RELIEF HOOD FOR ECONOMIZER (Furnished)

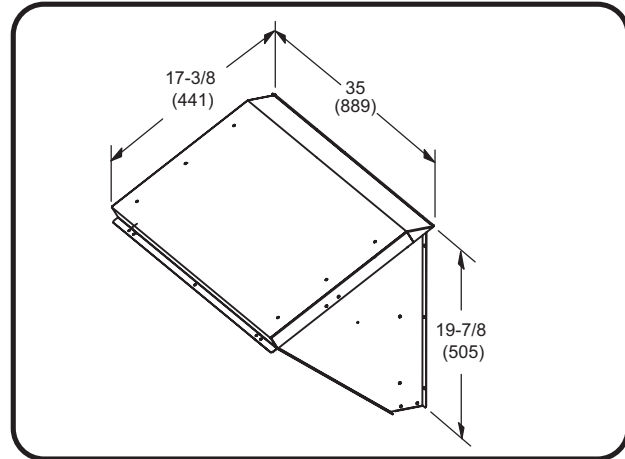

OUTDOOR AIR DAMPER HOOD DETAIL (Downflow or Horizontal Applications)

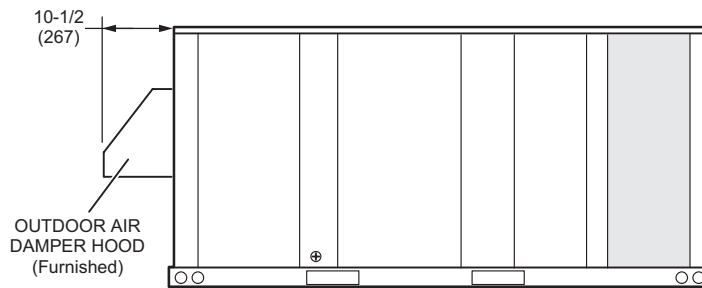

MANUAL OUTDOOR AIR HOOD

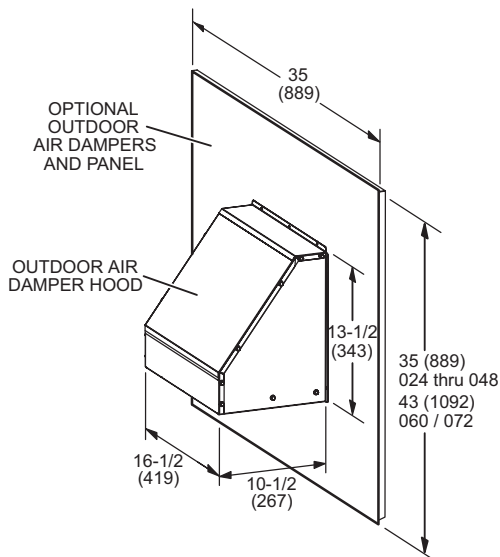

MOTORIZED OUTDOOR AIR HOOD

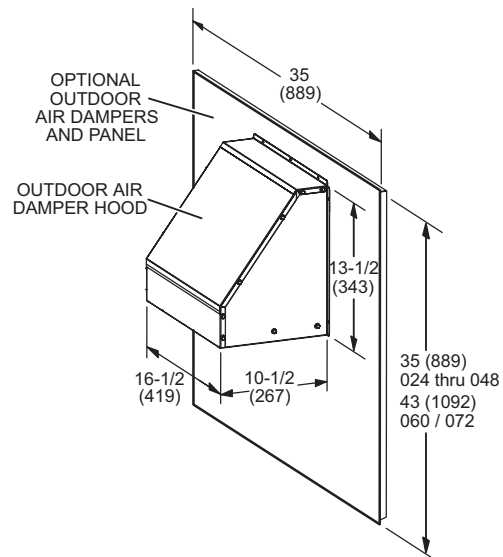

DIMENSIONS - ACCESSORIES - INCHES (MM)

OUTDOOR AIR HOOD DETAIL WITH OPTIONAL ECONOMIZER AND BAROMETRIC RELIEF DAMPERS (Horizontal Applications)

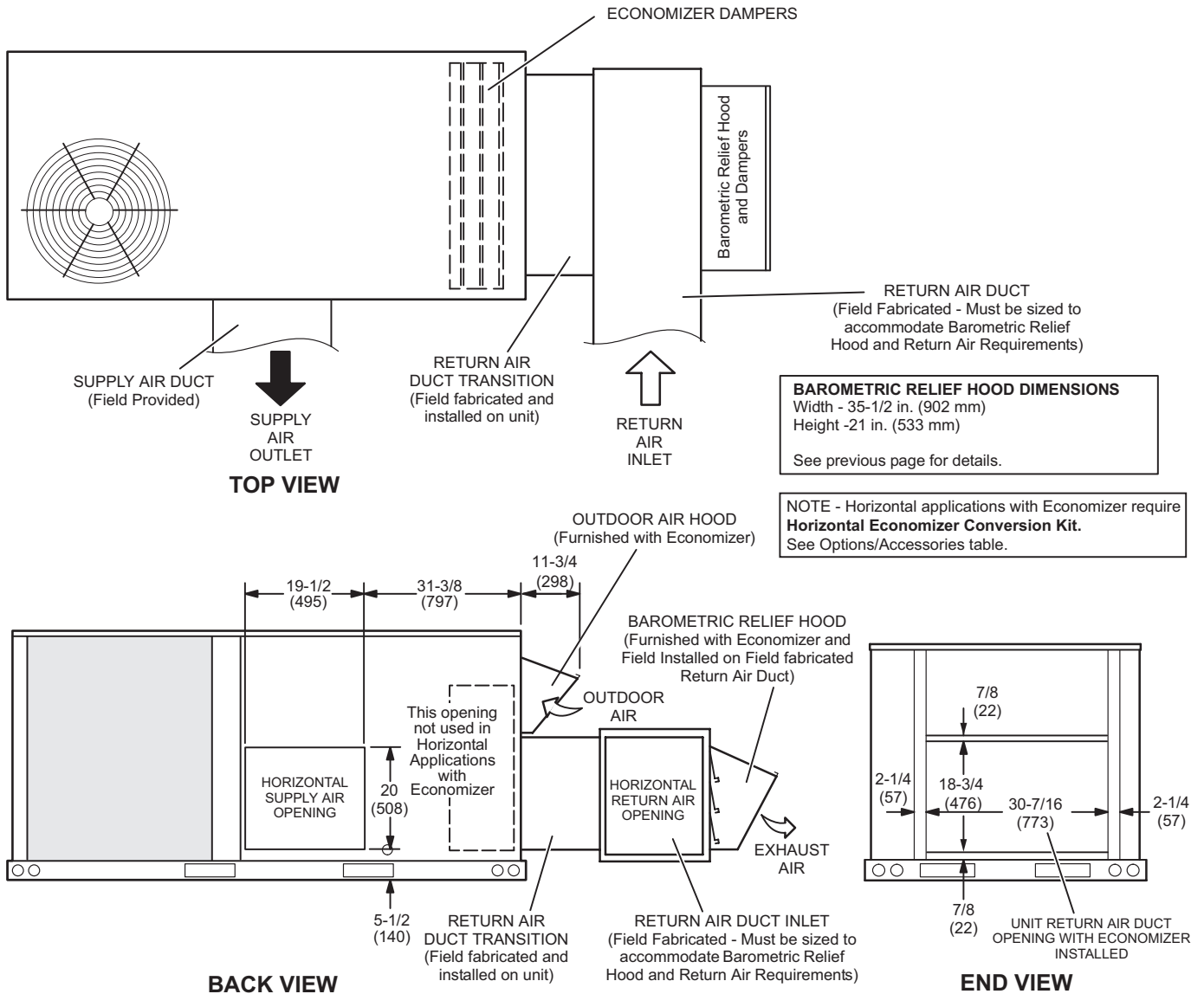

NOTE - Return Air Duct and Transition must be supported.

DIMENSIONS - ACCESSORIES - INCHES (MM)

HYBRID ROOF CURBS - DOUBLE DUCT OPENING - STANDARD AND FULL PERIMETER

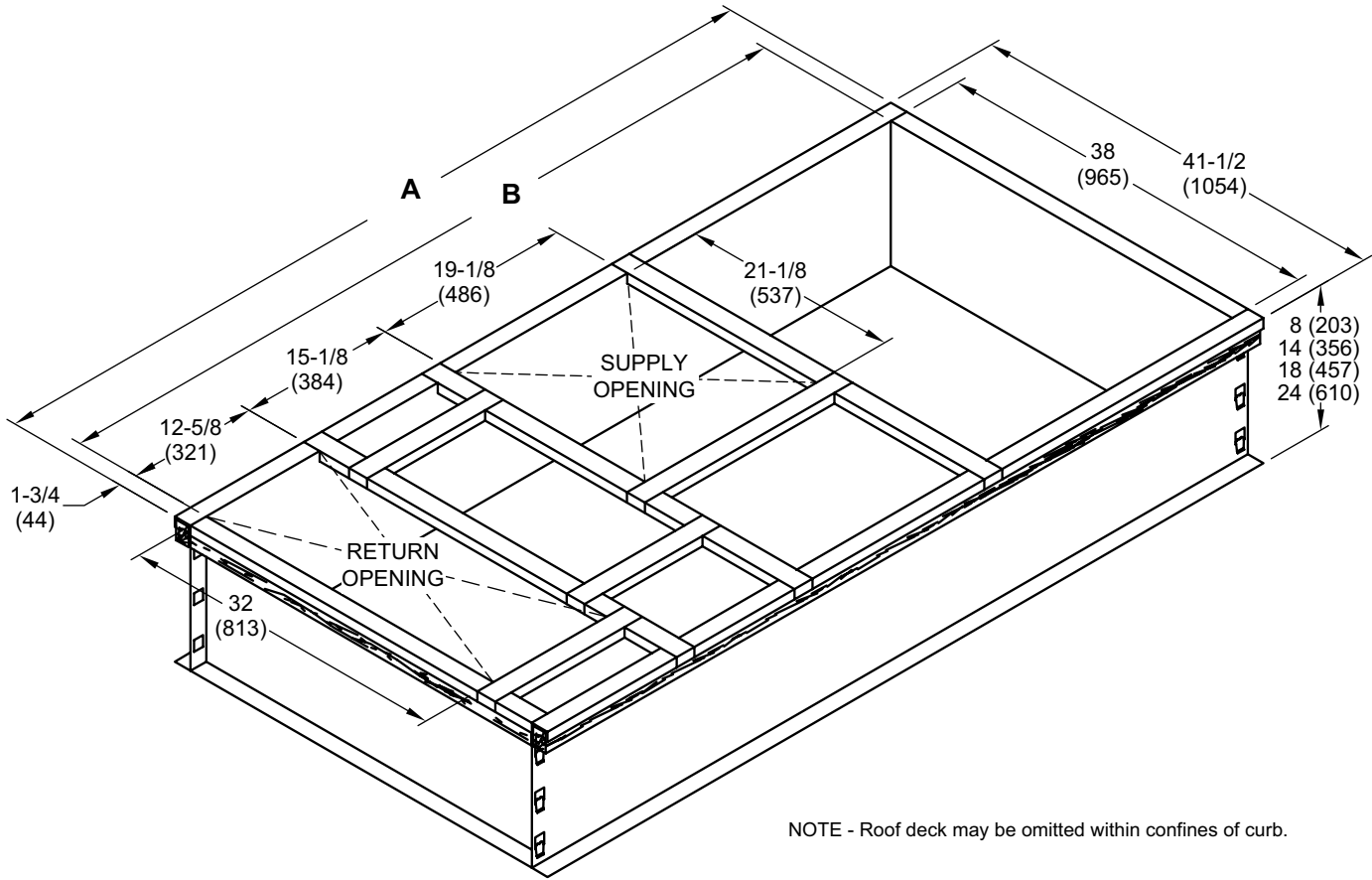

NOTE - Roof deck may be omitted within confines of curb.

TYPICAL FLASHING DETAIL FOR ROOF CURB

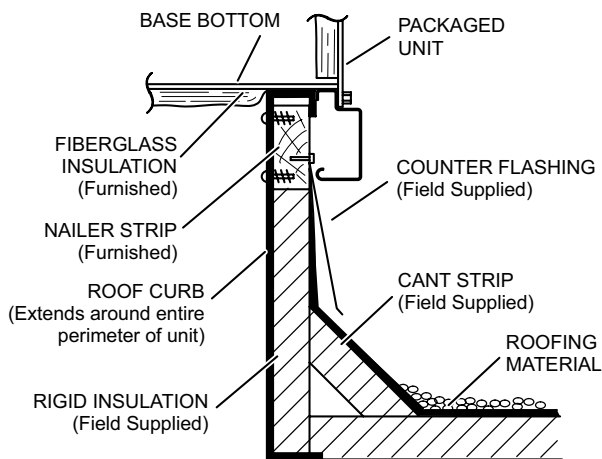

DETAIL ROOF CURB

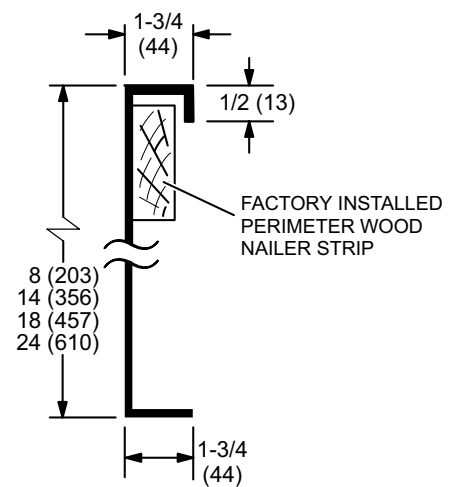

Model No.	A		B	
	in.	mm	in.	mm
Standard - 036, 048, 060, 072, ¹ 090	79-3/4	2026	76-1/4	1937
Full Perimeter - 090	92-3/4	2356	89-1/4	2267

¹ 090 models can be used on smaller 79-3/4 in. (2026 mm) roof curbs (not full perimeter) with 15-3/4 in. (400 mm) overhang at condenser end of unit. See dimension drawing on page 40

DIMENSIONS - ACCESSORIES - INCHES (MM)

ADJUSTABLE PITCH CURBS - DOUBLE DUCT OPENING

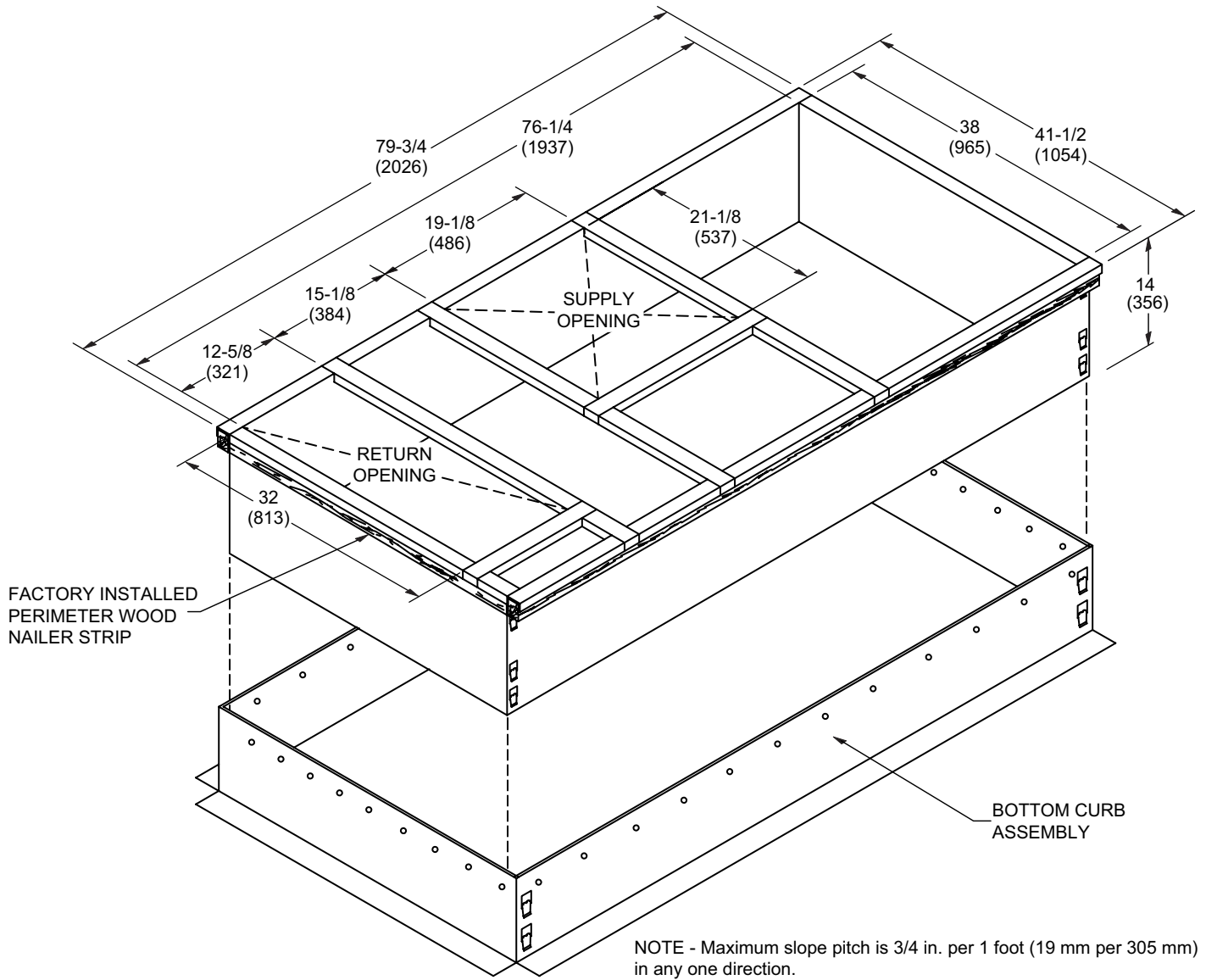

TYPICAL FLASHING DETAIL FOR ROOF CURB

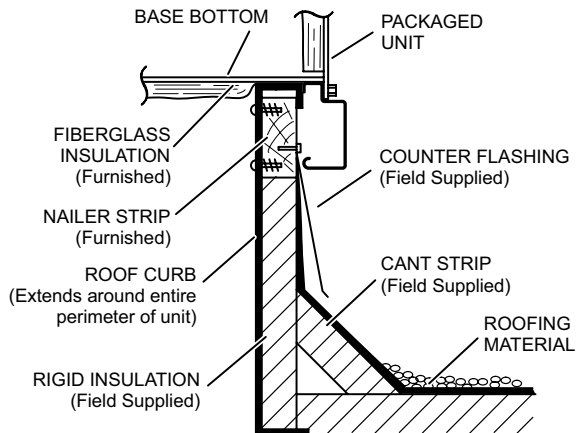

DETAIL ROOF CURB

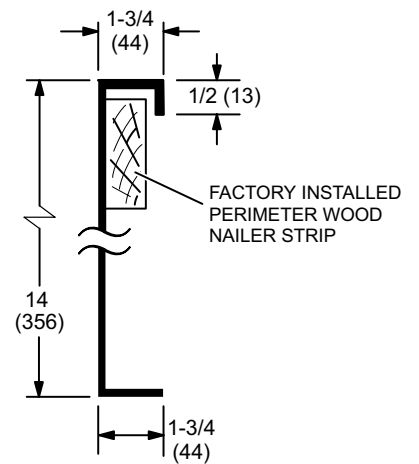

DIMENSIONS - ACCESSORIES - INCHES (MM)

090 MODELS - SHOWING OVERHANG ON SMALLER 79-3/4 INCH LENGTH ROOF CURBS
(Not Full Perimeter)

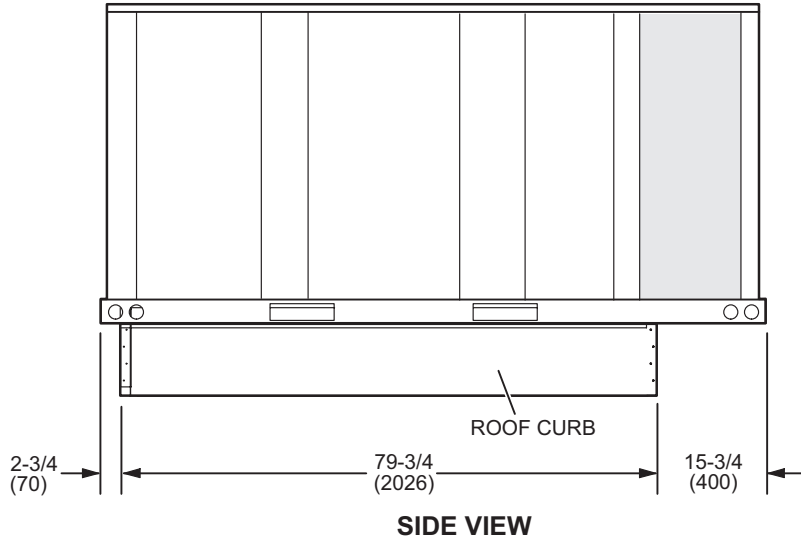

TRANSITIONS

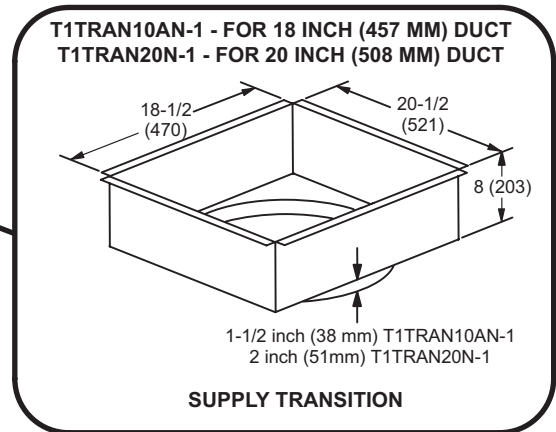
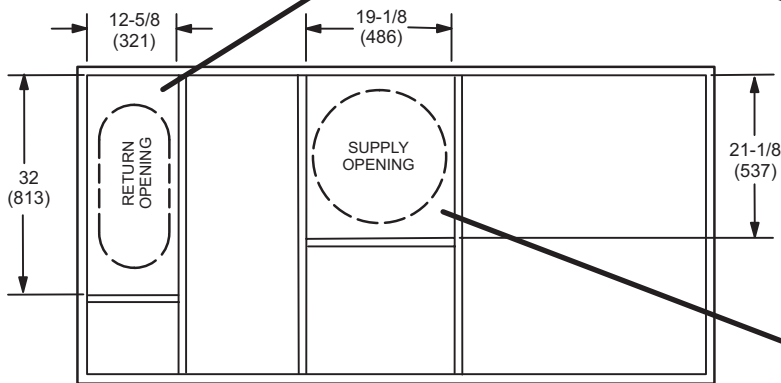
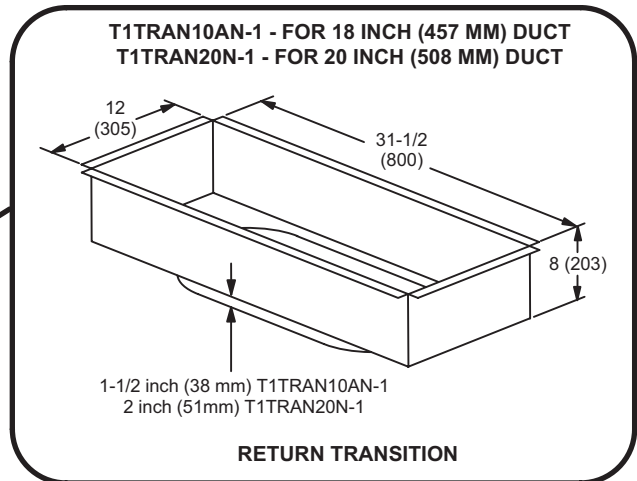

DIMENSIONS - ACCESSORIES - INCHES (MM)

COMBINATION CEILING SUPPLY AND RETURN DIFFUSERS

STEP-DOWN CEILING DIFFUSER

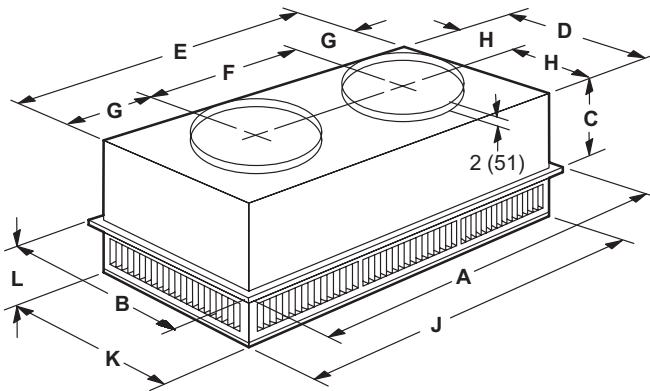

FLUSH CEILING DIFFUSER

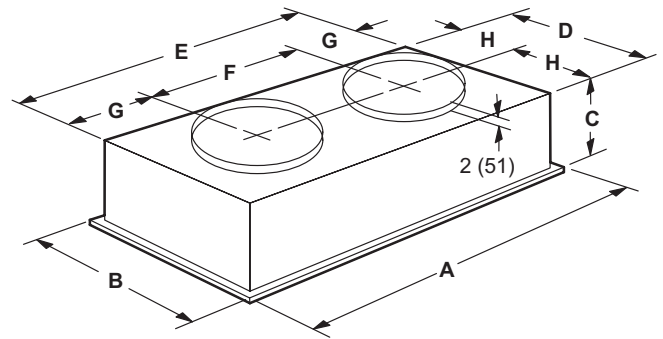

Model Number		RTD9-65S	RTD11-95S
A	in.	47-5/8	47-5/8
	mm	1159	1159
B	in.	23-5/8	29-5/8
	mm	600	752
C	in.	11-3/8	14-3/8
	mm	289	365
D	in.	21-1/2	27-1/2
	mm	546	699
E	in.	45-1/2	45-1/2
	mm	1156	1158
F	in.	22-1/2	22-1/2
	mm	572	572
G	in.	11-1/2	11-1/2
	mm	292	292
H	in.	10-3/4	13-3/4
	mm	273	349
J	in.	45-1/2	45-1/2
	mm	1156	1156
K	in.	21-1/2	27-1/2
	mm	546	699
L	in.	7-1/8	8-1/8
	mm	181	206
Duct Size	in.	18 round	20 round
	mm	457 round	508 round

Model Number		FD9-65S	FD11-95S
A	in.	47-5/8	47-5/8
	mm	1159	1159
B	in.	23-5/8	29-5/8
	mm	600	752
C	in.	13-1/2	16-5/8
	mm	343	422
D	in.	21	27
	mm	533	686
E	in.	45	45
	mm	1143	1143
F	in.	22-1/2	22-1/2
	mm	572	572
G	in.	11-1/4	11-1/4
	mm	286	286
H	in.	10-1/2	13-1/2
	mm	267	343
Duct Size	in.	18 round	20 round
	mm	457 round	508 round

REVISIONS

Sections	Description of Change
Optional Accessories	Updated model and catalog numbers for manual and motorized Outdoor Air Dampers with Outdoor Air Hood.
Dimensions	Added new Outdoor Air Damper Hood drawing for Motorized Dampers.



ALLIEDTM
Commercial

Visit us at www.allied-commercial.com

For the latest technical information, visit us at www.allied-commercial.com

Contact us at 1-800-448-5872

NOTE - Due to Allied Commercial ongoing commitment to quality, Specifications, Ratings and Dimensions subject to change without notice and without incurring liability. Improper installation, adjustment, alteration, service or maintenance can cause property damage or personal injury. Installation and service must be performed by a qualified installer and servicing agency.