

# INSTALLATION INSTRUCTIONS

## Low Global Warming Potential (GWP) Refrigerant Detection System (RDS) Non-Communicating Blower Control Board (24 Volts Only) Kit

This manual must be left with the homeowner for future reference.

### Contents

Certifications.....	2	Diagnostic Codes .....	11
Shipping and Packing List .....	2	<i>Red LED Diagnostic Codes</i> .....	11
Overview.....	3	Test Button Functionality .....	12
Operating Environment Specifications .....	3	<i>Test Button - Additional Functions</i> .....	13
Product Features .....	3	Thermostat Compatibility.....	13
Introduction.....	4	<i>Compatibility Verification</i> .....	14
RDS Non-Communicating Blower Control Board		Additional Applications.....	14
Dimensions.....	5	<i>Zone HVAC System</i> .....	14
Installation .....	6	<i>External Alarm</i> .....	14
<i>Sensor Part Number Verification</i> .....	6	Start Up Test Procedure .....	15
<i>Mounting Methods</i> .....	6	<i>Cooling Demand</i> .....	15
<i>Mounting Location</i> .....	6	<i>Heating Demand</i> .....	15
<i>Condensate Safety Switch (Float Switch)</i> ...	7	Wiring Diagrams .....	16
<i>Routing the Sensor Cable</i> .....	8	<i>Single Stage Air Conditioner with</i>	
<i>Making the Connection</i> .....	9	<i>Single Stage Indoor Unit</i> .....	16
DIP Switch Settings .....	10	<i>Single Stage Heat Pump with Air Handler</i> ...	17
Modes of Operation .....	10	<i>Two Stage Heat Pump with Two</i>	
<i>Initializing</i> .....	10	<i>Stage Furnace</i> .....	18
<i>Normal</i> .....	10	<i>Non-Communicating Zoning Control with Single</i>	
<i>Refrigerant Detected</i> .....	10	<i>Stage AC Unit</i> .....	19
<i>Fault</i> .....	11	Diagnostic Codes and Troubleshooting.....	20



(P) 508636-01

### **⚠WARNING**

Improper installation, adjustment, alteration, service or maintenance can cause property damage, personal injury or loss of life.

Installation and service must be performed by a licensed professional HVAC installer (or equivalent) or a service agency.

### **⚠WARNING**

All systems Charged with at least 4 lbs of low-GWP A2L-classified refrigerant are required to have a refrigerant detection system installed to prevent the build up of A2L refrigerant in enclosed spaces of the HVAC equipment. A refrigerant detection system may be required for systems that have less than 4 lbs of low-GWP refrigerant. For more information on this, contact Technical Support.

Installing a residential HVAC system with A2L-classified refrigerant without a refrigerant detection system may lead to a fire hazard within the home in the event of a refrigerant .

### **⚠WARNING**

The RDS Non-Communicating Blower Control Board has been tested with OEM matched coils only. Do not use a non-OEM refrigerant detection system controller or non-OEM refrigerant sensor with OEM coils. Do not use the RDS Non-Communicating Blower Control Board with non-OEM coils or air handlers.

### **⚠WARNING**

Improper installation of the RDS Non-Communicating Blower Control Board may lead to unreliable equipment operation and unreliable refrigerant detection.

In addition to installing the RDS Non-Communicating Blower Control Board, considerations must be made regarding sensor mounting location. Please refer to respective OEM air handler, coil, and/or sensor kit installation guides for further details.

### **⚠CAUTION**

Any service personnel installing, decommissioning, or performing maintenance on the unit. It is the responsibility of the licensed installer or service agency to obtain the appropriate training and/or certifications to work on A2L-classified HVAC systems with low GWP refrigerants.

### **⚠CAUTION**

Unit must remain powered except for service.

### **Certifications**

- CSA C22.2 No. 60335-2-40:22; Fourth ed.
- UL 60335-2-40; Fourth ed.

### **Shipping and Packing List**

Qty	Description	Cat. No.
1	OEM Low GWP Refrigerant Detection System	27A05
2	Mounting Hardware - #6-18 1" Phillips Drive pan head with dry wall anchor	N/A

**NOTE:** *This kit is sold separately from the refrigerant detection sensor. The refrigerant sensor is included as part of an OEM sensor kit, R454B-only coil, or R454B-only air handler.*

## Overview

Low GWP Refrigerant Detection System, Non-Communicating Blower Control Board, ensures nominal or proper operation of the OEM residential HVAC systems equipped with A2L-classified refrigerant. The RDS Non-Communicating Blower Control Board connects to the refrigerant detection sensor, the indoor unit, the outdoor unit and the thermostat to control the HVAC system in the event refrigerant is detected by the sensor. The RDS Non-Communicating Blower Control Board functions with standard 24VAC or OEM non-communicating control interfaces.

## Operating Environment Specifications

The Low GWP Refrigerant Detection Kit is designed to withstand the following conditions:

Condition	Temperature Range
Normal Operation	-40°F - 185°F (40°C - 85°C)
Shipping/Storage	
Functional Range	
Humidity	10% to 90% non-condensing at 104°F (40°C)

## Product Features

- Detects R-454B refrigerant and helps to prevent a concentration of refrigerant from reaching the lower flammability limit, in the event refrigerant is present outside of the coil itself.
- Multicolor LED (light-emitting diode) communicates RDS Non-Communicating Blower Control Board state
- Test/Reset button (to verify RDS Non-Communicating Blower Control Board functionality)
- Composite case with mounting hardware for drywall installations
- Supports up to two refrigerant detection sensors
- Supports standard 24VAC control for split systems HVAC equipment (Single-Stage, Two-Stage, Variable Speed, Heat Pump, AC, Gas Furnace, Air Handler) See “Thermostat Compatibility” on page 14.
- Compliant with UL-60355-2-40 & CSA
- Compatible with OEM approved sensor (see “Refrigerant Detection System Sensors” on page 7)
- Required when installing an OEM outdoor unit that use R454B refrigerant. Some indoor units may already feature refrigerant detection system control functionality and may not require this kit. Check indoor equipment installation guide to determine if the system comes with the refrigerant detection system already installed.

## Introduction

The Low GWP Refrigerant Detection System ensures safe operation of the residential HVAC systems equipped with low GWP A2L-classified refrigerant (R-454B).

The RDS Non-Communicating Blower Control Board activates the blower in the event the refrigerant concentration in the cabinet begins to rise. The control will activate the blower if the concentration reach 12% of the lower flammability limit (LFL) whereas the UL standard is 25% of the LFL. The Control board will also interrupt power to the ignition sources in the HVAC system when it detects refrigerant.

After refrigerant concentrations have been reduced to safe levels, the RDS Non-Communicating Blower Control Board allows the HVAC system to resume normal functionality. The HVAC system will operate normally if the RDS Non-Communicating Blower Control Board is functioning.

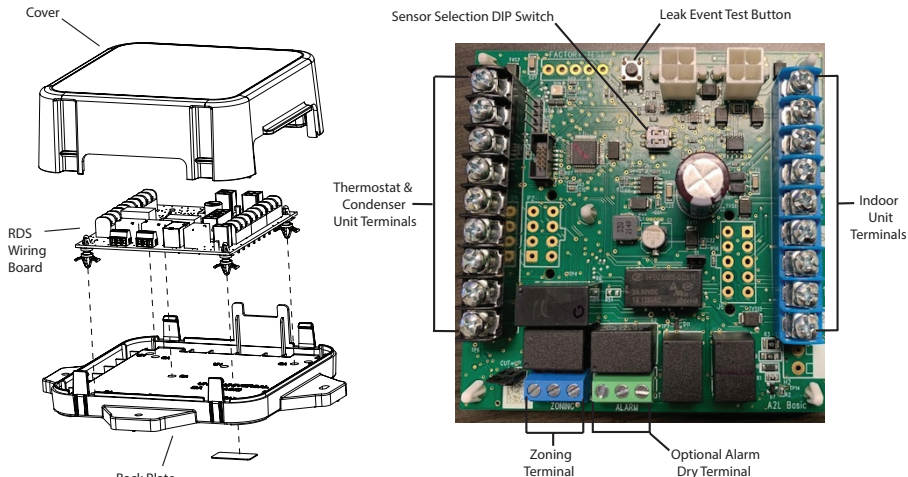

**Figure 1. RDS Non-Communicating Blower Control Board**

## RDS Non-Communicating Blower Control Board Dimensions

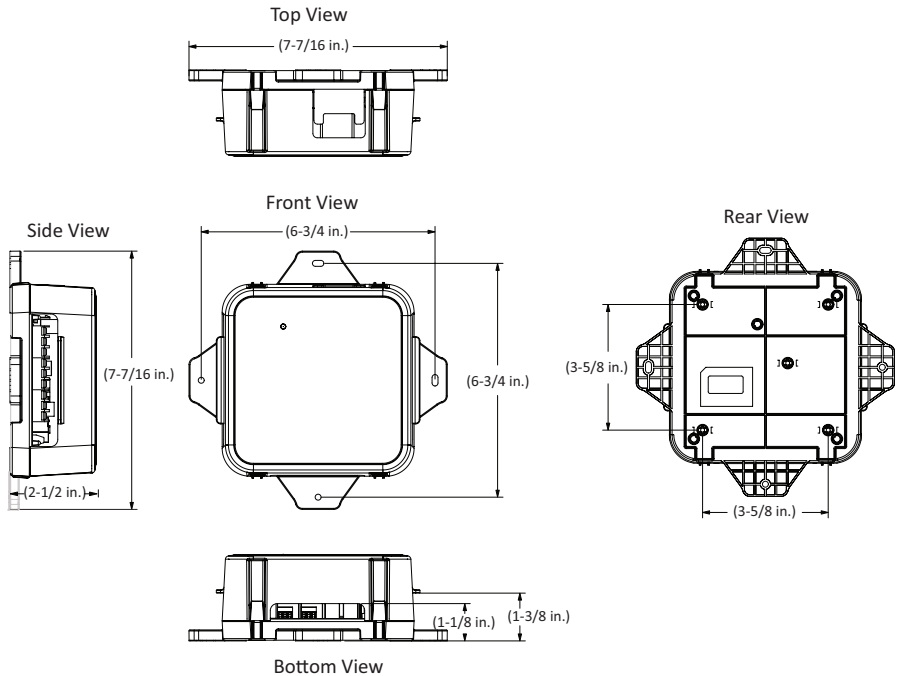

Figure 2. RDS Non-Communicating Blower Control Board Dimensions

## Installation

### Sensor Part Number Verification

Verify the refrigerant detection system sensor's part number, which is found on the sensor/cable, prior to installation. The part number is 107648-01.

**NOTE:** *All sensors paired to a single RDS Non-Communicating Blower Control Board **must share the same part number** (107648-01) to ensure the RDS Non-Communicating Blower Control Board will function properly.*

### Mounting Methods

Some mounting surfaces may be difficult to access after the RDS Non-Communicating Blower Control Board is installed. To avoid this or a similar situation wire the RDS Non-Communicating Blower Control Board unit *prior* to mounting in a confined space.

For drywall/closet installations, use the included drywall hardware. For attic/crawl-space/basement installations, use the included and field-provided hardware.

### Mounting Location

The RDS Non-Communicating Blower Control Board can be mounted to the indoor unit, plenum, a stud, or joist in an attic, crawlspace, or other unfinished area within 48 inches of the refrigerant sensor cable grommet on the coil or air handler. Drywall anchors and screws are provided for installation in finished areas,

such as closets. Mount the RDS Non-Communicating Blower Control Board in a clean, dry environment that is away from dust, water, and other contaminant accumulation.

**NOTE:** *Mounting the RDS Non-Communicating Blower Control Board farther than 48 inches away from the refrigerant sensor may prevent reliable operation due to cable strain and water seepage on cable connections.*

- **Do not** place the RDS Non-Communicating Blower Control Board in secondary drain pan
- Use the screws provided to mount the RDS Non-Communicating Blower Control Board
- Tighten the screws to a snug fit

**NOTE:** *Do not over-tighten the screws. Over-tightening the screws may strip the hardware and apply excessive stress on the enclosure.*

### Refrigerant Detection System Sensor

*(sold separately)*

The refrigerant detection system sensor must be mounted as specified in its accompanying manual. Mounting the sensor incorrectly or in an improper location may result in refrigerant detection failure.

## Condensate Safety Switch (Float Switch)

In applications that require a condensate safety switch (float switch) the float switch must be wired between the room thermostat and the Refrigerant Detection System. The float switch's normally closed contacts may be wired to interrupt the "R" wire or the "Y" wire between the thermostat and the RDS Non-Communicating Blower Control Board. See the RDS Non-Communicating Blower Control Board wiring diagrams. This ensures the RDS Non-Communicating Blower Control Board is powered continuously and operates normally. Do not wire the condensate safety switch or any other field installed safety switches between the indoor unit transformer and the RDS Non-Communicating Blower Control Board. The RDS Non-Communicating Blower Control Board must remain powered at all times.

## Refrigerant Detection System Sensors

The OEM Refrigerant Detection System requires an OEM RDS sensor located in the indoor coil. See table below.

Indoor Unit Model	RDS Sensor Catalog No.	Description
<ul style="list-style-type: none"><li>• 7EC/NCU/BC7 Upflow</li><li>• 7EH/NCH/BC7 Horizontal</li><li>• 7ED/NCD/BC7 Downflow "Revision 01" Coils</li></ul>	26Z69	Refrigerant Detection System (RDS) Coil Sensor Kit
<ul style="list-style-type: none"><li>• 7AH1AC/NAM/BHA/HMA</li><li>• 7AH1AE/NAM/BHA/HMA</li><li>• 7AH1AV /NAM/BHA/HMA</li><li>• 7AH2AE /NAM/BHA/HMA "Revision 01" Air Handlers</li></ul>	27J27	RDS Air Handler Sensor Kit
<ul style="list-style-type: none"><li>• 7EC/NCU/BC7 Upflow</li><li>• 7EH/NCH/BC7 Horizontal</li><li>• 7ED/NCD/BC7 Downflow "Revision 71" Coils</li></ul>	Factory Installed	RDS Sensor is Factory Installed in "Revision 71" Coils
All R-454B Coils & Air Handlers	27V53	Sensor Repair Kit (Replacement Sensor only, without mounting bracket & components provided in the Sensor Kit)

## Routing the Sensor Cable

Figure 3 illustrates how to best route the sensor cable from the RDS Non-Communicating Blower Control Board to the sensor within the indoor unit for the Upflow, Downflow, and Horizontal orientations. For details on mounting the sensor itself, refer to the respective sensor kit, air handler, or coil installation guide.

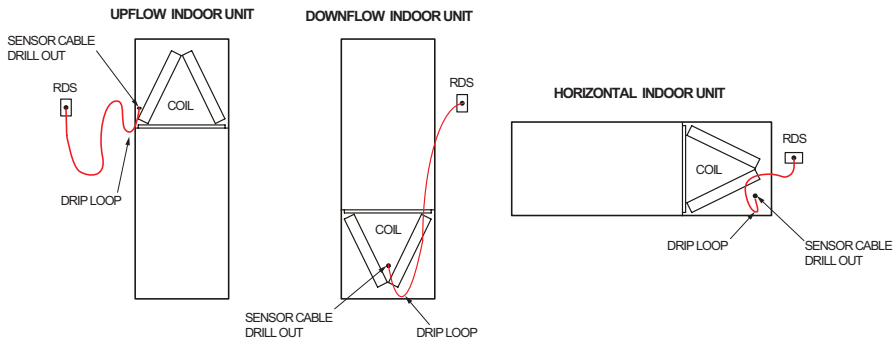

**Figure 3. Routing the Sensor Cable**

### **⚠WARNING**

Do not strap the RDS Non-Communicating Blower Control Board to existing tubing or other electrical cables” with the following “Do not strap the RDS Non-Communicating Blower Control Board to existing tubing or other electrical cables, since they are not designed to have equipment strapped to them and can cause them to become disconnected.



## Making the Connection

Ensure the cable is properly connected into the number one (1) sensor plug. The Molex plug clip should lock into the Molex connection point for a secured connection, as shown below in Figure 4. Verify the connection is free of dust, debris, and moisture.

Molex Plug Clip

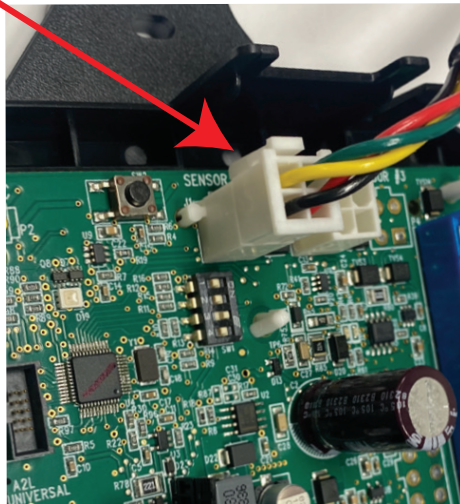

Figure 4. Connecting the RDS Sensor to RDS Non-Communicating Blower Control Board

## DIP Switch Settings

Adjust the DIP switch settings to the sensor configuration. Failure to do so will cause faults on power-up.

**Table 1. DIP Switch Settings**

Configuration	DIP1	DIP2
Two (2) sensors expected; in connector 1 and 2	OFF	OFF
One (1) sensor expected; in connector 1	OFF	ON

Configurations other than the ones shown above will cause a service fault.

Each DIP switch corresponds to a sensor position (i.e., DIP switch 1 to sensor 1; DIP switch 2 to sensor 2). The default factory switch positions are set to OFF. The RDS software reads the OFF position as an active sensor. A sensor should be present for the corresponding sensor connector. Setting the DIP switch to ON disables the sensor position.

**NOTE:** Refer to 508467-01 (*Installation Instructions for Refrigerant Detection Sensor Kit - Indoor Coils*) to determine whether more than one (1) Refrigerant Detector Sensor is required.

## Modes of Operation

The modes of operation for the RDS Non-Communicating Blower Control Board are Initializing, Normal, Refrigerant Detected, and Fault.

### Initializing

The RDS Non-Communicating Blower Control Board is establishing connection with the refrigerant detection sensor and is completing an initial five (5) minute purge sequence.

### Normal

The HVAC system is functioning normally. The RDS Non-Communicating Blower Control Board has not detected refrigerant.

### Refrigerant Detected

When the RDS Non-Communicating Blower Control Board detects refrigerant :

1. The RDS Non-Communicating Blower Control Board shuts off the (R) input (24VAC power) to the thermostat, which de-energizes the outdoor unit compressor and heat sources, such as gas and/or electric strip heat. No heating or cooling demands will be met.
2. The RDS Non-Communicating Blower Control Board activates the blower (high speed). The blower purges refrigerant from the cabinet, plenum, and ductwork.
3. After the RDS Non-Communicating Blower Control Board determines the refrigerant levels are below the safety

threshold, the blower will continue to function for an additional seven (7) minutes.

- After the blower sequence is complete, the HVAC system resumes normal operation.

**NOTE:** *The HVAC system may not maintain a cooling or heating setpoint if a significant refrigerant exists. Any refrigerant that remain unaddressed for an extended time may cause the HVAC system to shut down on a low refrigerant pressure limit condition.*

## Fault

When a fault is detected within the RDS Non-Communicating Blower Control Board, the indoor unit blower engages and remains engaged at a constant output until the fault is cleared.

## Diagnostic Codes

The RDS Non-Communicating Blower Control Board is equipped with a multicolor LED within its enclosure. The LED signals the state of the RDS Non-Communicating Blower Control Board.

See Table 2 to review the diagnostic codes.

**Table 2. LED Diagnostic Codes**

State	LED Diagnostic Code	Action
Initializing	Flashing green <sup>1</sup>	Not Applicable
Monitoring	Solid green with blue flash <sup>2</sup>	Not Applicable
Refrigerant Detected	Flashing blue	Check coil tubes for refrigerant Repair the issue and restart the equipment.
Fault/Service	Solid blue, interrupted by issue flash code	Refer to Table 7 for troubleshooting steps.

- A rapid flash indicates the RDS Non-Communicating Blower Control Board is in the process of sensor enumeration
- A blue flash indicates the sensor has previously detected refrigerant and ran its sequence of operation.

## Red LED Diagnostic Codes

Red diagnostic codes indicate a specific RDS Non-Communicating Blower Control Board issue. Yellow diagnostic codes indicate the sensor's position (if applicable).

**Table 3. Red LED Diagnostic Codes**

<b>Red Flash</b>	<b>Applies to Individual Sensor(s)</b>	<b>Issue</b>	<b>Action</b>
1	Yes	Sensor indicates fault	Replace the sensor (Cat. # 26Z69)
2	No	Spare Code - Unused	Not Applicable
3	Yes	Incompatible sensor type	Replace with a compatible sensor (Cat. # 26Z69)
4	Yes	Sensor communications issue	Check sensor connection. Ensure connection is clean and tight.
5	No	R-input not available	Check for 24VAC power connection to the R terminal inputs on the RDS Non-Communicating Blower Control Board. R-inputs must be energized for the RDS Non-Communicating Blower Control Board to function.

**Table 3. Red LED Diagnostic Codes**

<b>Red Flash</b>	<b>Applies to Individual Sensor(s)</b>	<b>Issue</b>	<b>Action</b>
6	No	Invalid configuration of sensor count	Verify the DIP switch setting is correct and matches the number of sensors being used.

## Test Button Functionality

The RDS Non-Communicating Blower Control Board is equipped with a Test/Reset button. The Test button can be used to complete several functions, depending on the mode of operation of the RDS Non-Communicating Blower Control Board, .

Table 4 lists the functions of the Test button during each mode of operation.

**Table 4. Test Button Function**

Mode of Operation	Press the Test Button to...
Normal	Trigger a Refrigerant detection response. Verify all equipment is wired correctly into the RDS Non-Communicating Blower Control Board (after installation).
Refrigerant Detected	Reset the RDS Non-Communicating Blower Control Board to a normal mode of operation after refrigerant has been detected and purged from the HVAC system.
Fault	Reset the RDS Non-Communicating Blower Control Board after troubleshooting and resolving a fault condition. If the fault is not resolved, the RDS Non-Communicating Blower Control Board will enter the Fault mode again.

## Test Button - Additional Functions

Table 5 lists the additional functions of the Test Button while the RDS Non-Communicating Blower Control Board, is functioning within the states of Initializing, Monitoring, Refrigerant Detection, Servicing and Fault. Refer to “Table 2. LED Diagnostic Codes” on page 11.

**Table 5. Additional Button Functions**

State	Press	Action
Initializing	Short	Skips remaining pre-purge after sensors are recognized by the RDS
Initializing	Long	Reset control
Monitoring	Short	Clear purge-counter if prior refrigerant detection response has occurred; Test refrigerant detection response
Monitoring	Long	Reset control
Refrigerant Detected	Short	If testing refrigerant detection cycle, end test
Servicing	Short	Reevaluate fault condition - if cleared return to monitoring, otherwise update indicator
Servicing	Long	Reset control
Fault	Short	Reevaluate fault condition - if cleared return to monitoring, otherwise update indicator
Fault	Long	Reset control

## Thermostat Compatibility

Thermostats that preserve memory settings are compatible with the RDS Non-Communicating Blower Control Board. Examples include:

- Battery-powered thermostats
- Analog thermostats
- Smart thermostats
- Late-model programmable thermostats

**NOTE:** *Early-generation digital and programmable thermostats may not retain the operation mode and temperature setpoints after a power outage.*

The following scenarios are likely to occur when home occupants are not available to adjust the thermostat setpoints as the system is recovering from refrigerant detection and resuming normal operation:

- Heating could be lost during a cold night
- Cooling could be lost during a hot day
- The thermostat could reset to an incorrect temperature setpoint

## Compatibility Verification

Complete the following process to determine whether the thermostat is compatible with the RDS Non-Communicating Blower Control Board.

1. Change the thermostat's current setpoint and operating mode.
2. Power cycle the breaker to the furnace or air handler.

**NOTE:** *Wait five (5) minutes before supplying power to the furnace or air handler breaker.*

3. Note whether the thermostat maintained its setpoints and operating mode.
  - a. If the thermostat maintained the settings, the thermostat is compatible with the RDS Non-Communicating Blower Control Board.
  - b. If the thermostat did not maintain its setpoint and/or operating mode, the thermostat is not compatible with the RDS Non-Communicating Blower Control Board. Recommend replacing with a compatible thermostat.

## Additional Applications

In zoned applications, all dampers will remain open when the RDS Non-Communicating Blower Control Board is in Fault or Refrigerant Detected mode. Normal heating and cooling demands are permissible, but the blower will remain engaged until the fault condition is addressed.

### Zone HVAC System

If the RDS Non-Communicating Blower Control Board is installed in a zone HVAC system, the RDS Non-Communicating Blower Control Board will open all zone dampers if refrigerant is detected.

**NOTE:** *Proper wiring of the zone panel to the RDS Non-Communicating Blower Control Board is required for all zone dampers to open.*

After the purge sequence is complete, the zone system will resume normal operation.

### External Alarm

*(For applications with external alarms wired directly to the RDS Non-Communicating Blower Control Board.)*

The RDS Non-Communicating Blower Control Board triggers the external alarm system when it enters Refrigerant Detected mode. For alarm notifications, the RDS Non-Communicating Blower Control Board provides a dry relay contact that is rated 3A at 30 VAC/DC.

## Start Up Test Procedure

The RDS Non-Communicating Blower Control Board is equipped with a Test/Reset button, see “Test Button Functionality” on page 13. After the RDS Non-Communicating Blower Control Board has been mounted and wired, restore power to the HVAC system. The system will then run through a purge sequence for five (5) minutes. After the purge sequence is complete, proceed to testing cooling demand and heating demand.

### Cooling Demand

1. Prompt a cooling demand at the thermostat.
2. Press the Test button on the RDS Non-Communicating Blower Control Board.  
The system then executes a refrigerant detection response.
3. Observe the following sequence:
  - a. The LED indicator flashes the sequence for refrigerant detection (flashing blue).
  - b. The blower powers up.
  - c. The outdoor compressor powers down.
4. Press the Test button to terminate the simulated Refrigerant Detected mode upon test completion.

## Wiring Diagrams

OEM provides wires designated for wiring the sensor cable. Wires required for the RDS installation is field supplied.

The RDS supports OEM and non-OEM split gas furnace installations. Wiring diagrams are provided for several common split furnace system configurations to identify exact wire types and terminal locations.

### Single Stage Air Conditioner with Single Stage Indoor Unit

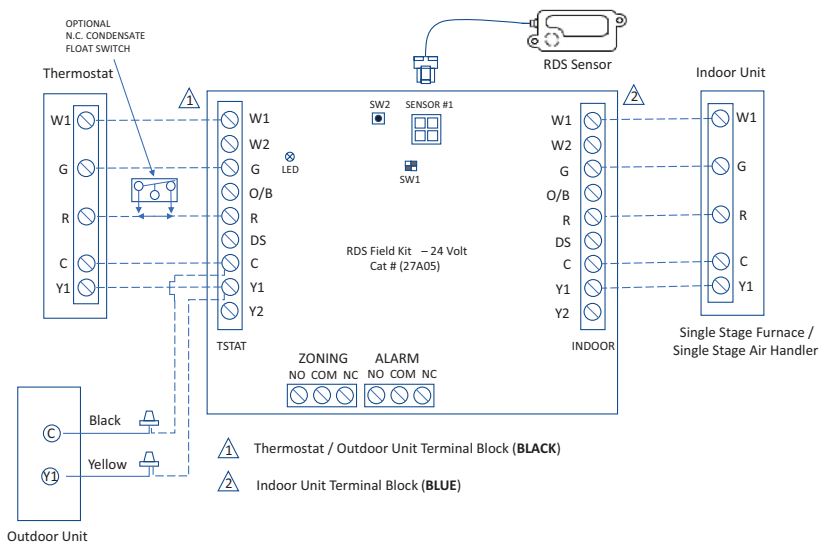



# Single Stage Heat Pump with Air Handler

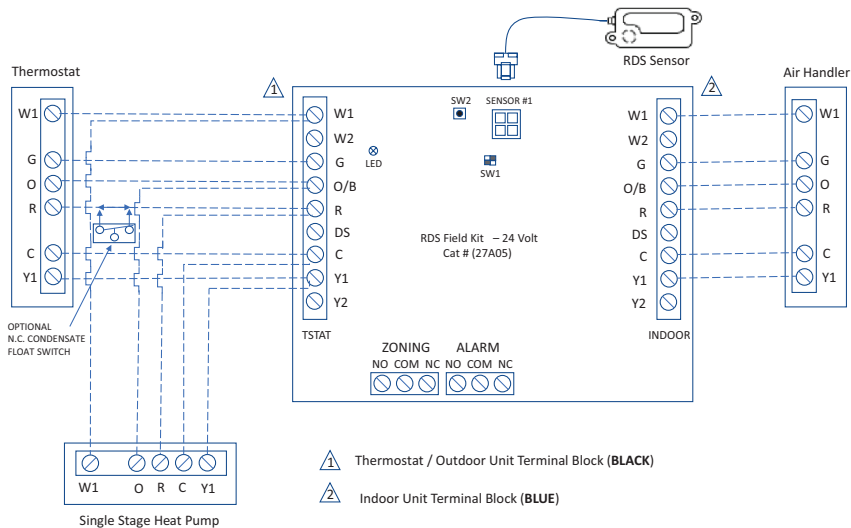

## Two Stage Heat Pump with Two Stage Furnace

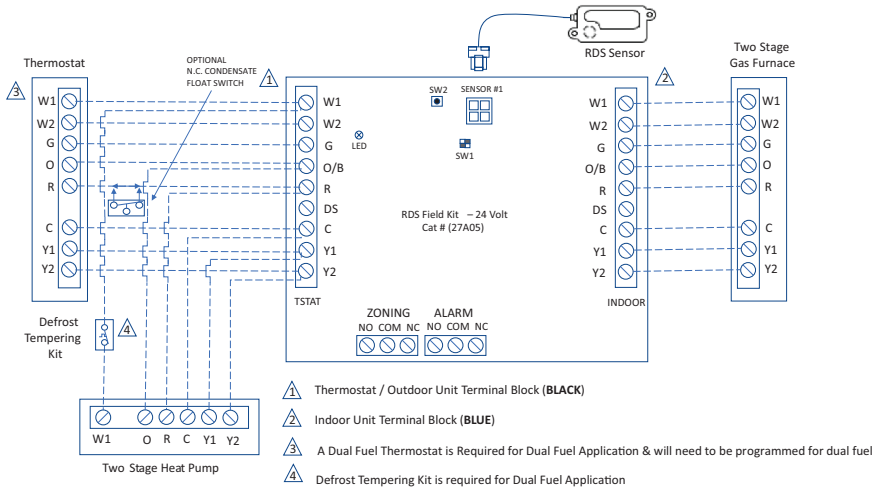

## Non-Communicating Zoning Control with Single Stage AC Unit, Indoor Unit, and Thermostat

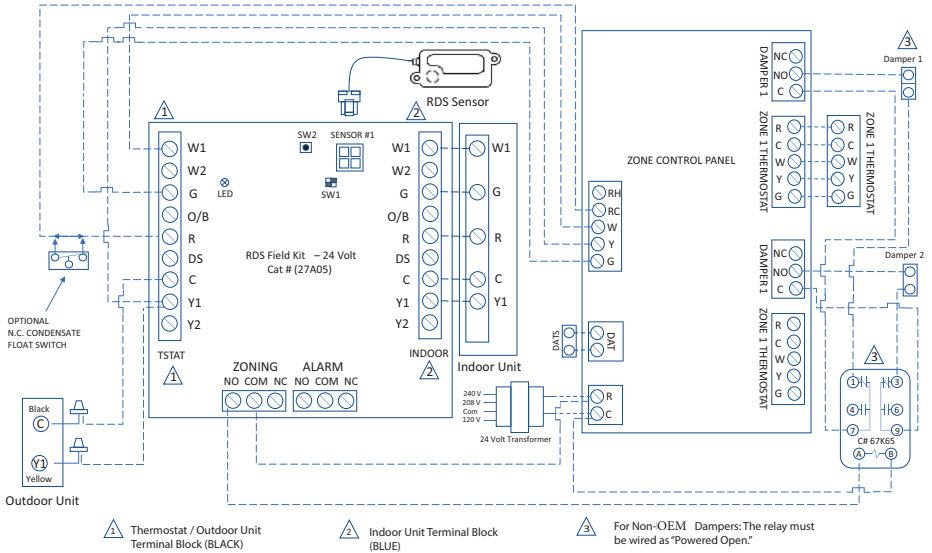

## Diagnostic Codes and Troubleshooting

Table 6. LED Diagnostic Codes

State	LED Diagnostic Code	Action Required
Initializing	Flashing green	None
Monitoring	Solid green. If refrigerant has been detected previously, a blue flash interrupts the solid green LED.	None
Refrigerant Detected	Flashing blue	Check coil tubes for refrigerant. Repair the issue and restart the equipment.
Fault/Service	Solid blue, interrupted by issue diagnostic code	Refer to Table 7 for troubleshooting steps.

Table 7. Red LED Diagnostic Codes / Troubleshooting

Red Flash	Applies to Individual Sensor(s)	Issue	Action Required
1	Yes	Sensor indicates fault	Replace the sensor (See "Refrigerant Detection System Sensors" on page 7.)
2	No	Spare Code - Unused	Not Applicable
3	Yes	Incompatible sensor type	Replace the sensor (See "Refrigerant Detection System Sensors" on page 7.)
4	Yes	Sensor communications issue	Check sensor connection. Ensure connection is clean and tight.
5	No	R-input not available	Check sensor connections. Ensure connection is clean and tight.
6	No	Invalid configuration of sensor count	Verify the DIP switch setting is correct and matches the number of sensors being used.