

## CYCLONE<sup>®</sup> Xi

### 96% THERMAL EFFICIENCY VERSATILE POWER DIRECT VENT

The Cyclone Xi is a light-duty, power direct vent, fully condensing commercial gas water heater with an internal helical heat exchanger. This helical heat exchanger helps Cyclone Xi achieve 96% thermal efficiency and deliver outstanding hot water output and is ENERGY STAR<sup>®</sup> Qualified.

#### HELICAL INTERNAL HEAT EXCHANGER

- Completely surrounded by water in tank, provides much greater heat transfer surface than standard straight flue tube
- Operates at 96% thermal efficiency, which saves money on operating costs, increases hot water output compared to standard efficiency water heaters
- Minimizes standby losses by trapping heat in the tank
- Spiral heat exchanger reduces the accumulation of lime scale, to help maintain higher efficiency performance over time.

#### VERSATILE POWER DIRECT VENT DESIGN

- Uses inexpensive PVC, CPVC or ABS pipe. Canadian installations require ULC S636 approved PVC or CPVC for venting. Can be vented vertically thru-the-roof or horizontally thru-the-wall
  - 2" pipe, vents up to 45 equivalent feet
  - 3" pipe, vents up to 128 equivalent feet
- Optional concentric vent and sidewall termination kits available

#### CONDENSING DESIGN

- 96% efficient condensing design
- Equipped with condensate drain tee

#### HIGH OUTPUT WITH SMALL FOOTPRINT

- 22" diameter, combined with 96% efficiency, 50-gallon tank and 100,000 BTU input means Cyclone Xi can be installed in less space than a larger 75-gallon unit, with equal or better performance
- Total height is 66-3/4" to top of unit

#### SIDE-MOUNTED HOT AND COLD RECIRCULATING TAPS

- Allows Cyclone Xi to be installed as part of combination space heating/water heating applications, or any system requiring a recirculating hot water loop
- Plugs for the recirculating taps are factory installed

#### ADVANCED ELECTRONIC CONTROL

- Large LCD display
- Precise temperature control
- Advanced diagnostics
- iCOMM™ Compatible and can be monitored from remote locations. Call 1.888.WATER02 for more information.



#### PERMAGLAS<sup>®</sup> ULTRA COAT™ GLASS LINING

- A. O. Smith exclusive process provides superior protection against corrosion
- Protects all interior tank surfaces including inside and outside of helical heat exchanger

#### TWO HEAVY-DUTY ANODE RODS

- Provides advanced protection against corrosion

#### AVAILABLE IN NATURAL GAS AND PROPANE

#### TOP-FIRED LOW NO<sub>x</sub> GAS BURNER

- Complies with California SCAQMD Rule 1146.2 and other Air Quality Management Districts with similar requirements for NO<sub>x</sub> emissions of 14ng/j or 20 ppm

#### CSA CERTIFIED AND ASME RATED T&P RELIEF VALVE

#### MAXIMUM HYDROSTATIC WORKING PRESSURE: 150 PSI

#### CODES AND STANDARDS

- Design-certified by Underwriters Laboratories (UL) according to ANSI Z21.10.3-CSA 4.3 standards governing storage-type water heaters
- These models meet or exceed the thermal efficiency and standby loss requirements of the U.S. Department of Energy and current edition of ASHRAE/IESNA 90.1

## BTX-100



## SERIES 124/125

GAS-FIRED



GAS-FIRED





**96% THERMAL EFFICIENCY  
VERSATILE POWER DIRECT VENT**

**THREE-YEAR LIMITED TANK WARRANTY**

■ For complete warranty details, consult written warranty shipped with heater or contact A. O. Smith

**SPECIFICATIONS**

MODEL NUMBER	BTU INPUT PER HOUR	GALLONS OR LITRES	TANK SIZE	RECOVERY - GALLONS OR LITRES PER HOUR AT DEGREE RISE			SHIPPING WEIGHT
				40°F	100°F	140°F	
				22°C	56°C	78°C	
BTX-100	100,000	Gallons	50	291	116	83	255 lbs
		Litres	189	1102	439	314	115.7 kg's

Maximum Supply Pressure: 14 inches W.C. (3.48kPa) ■ Minimum Supply Pressure for Natural Gas: 3.50" (.87kPa) ■ Minimum Supply Pressure for Propane Gas: 8.00" (1.99kPa)  
Minimum pressure must be maintained under both load and no load (dynamic and static) conditions. ■ Electrical Characteristics - 120V, 60Hz, Amperes <5  
Approved for installation up to 10,100 Ft. Consult factory for installation above 10,100 ft

Approved for Canada

**DIMENSIONS**

BTX-100	A	B	C	D	E	F
INCHES	66-3/4	49-1/4	22	15-3/4	3	8
CM	169.55	125.09	55.88	40	7.62	20.32

Top inlet and outlet: 3/4" male NPT ■ Side inlet and outlet: 3/4" female NPT ■ Gas inlet: 1/2" NPT ■ Available natural gas and propane

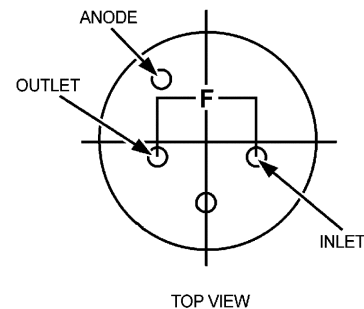
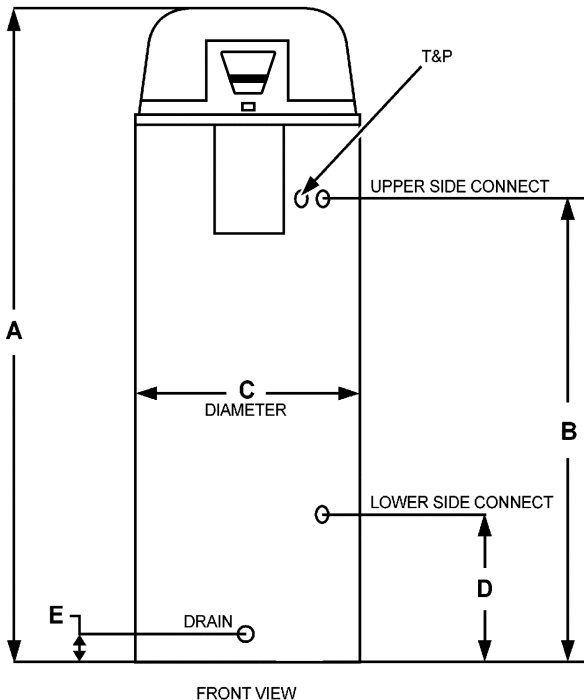

INSTALL IN ACCORDANCE WITH LOCAL CODES.

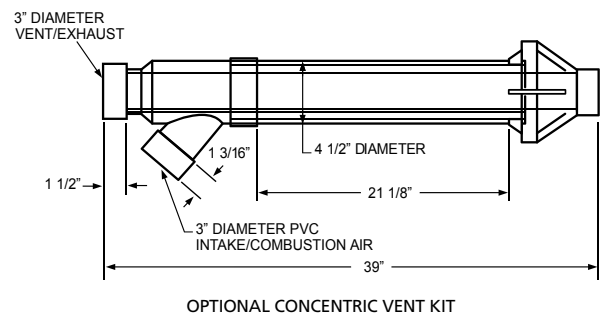

**SUGGESTED SPECIFICATION**

(Natural or Propane) gas water heater(s) shall be A. O. Smith Cyclone Xi model # BTX-100, with 96% thermal efficiency, a storage capacity of 50 gallons, an input rating of 100,000 BTUs per hour, a recovery rating of 116 gallons per hour at 100°F rise and a maximum hydrostatic working pressure of 150 psi. Water heater(s) shall be of power direct vent design, using 2" or 3" PVC pipe for horizontal and/or vertical vent runs. Water heater(s) shall have: 1: Seamless, glasslined steel tank construction and a spiral-shaped heat exchanger placed entirely inside the tank, which shall be glasslined on the flue gas side to protect against acidic condensate. 2: Advanced electronic control w/ LCD display and actual diagnostic. 3: A 3-year limited warranty against tank leaks. Water heater(s) shall meet the thermal efficiency and standby loss requirements of the U.S. Department of Energy and current edition of ASHRAE/IESNA 90.1 and be design-certified by UL (Underwriters Laboratories) according to ANSI Z21.10.3-CSA 4.3 standards governing storage tank water heaters.  
Water heater should incorporate the iCOMM™ system connection for remote monitoring, leak detection and fault alert.