



MODEL 53

Sump, Effluent or Dewatering Pumps



Model 53® Features:

- 3-year warranty
- 3/10 HP 115 V sump pump; 230 V also available
- Performance up to 19.25' (5.9 m)
- Flows up to 43 GPM (163 LPM)
- Cast iron case cover, base, motor and pump housing
- Engineered thermoplastic base
- Zoeller LED Plug that allows you to check for power at a quick glance
- Corrosion-resistant, powder coated epoxy paint

100% factory tested

PRODUCT SPECIFICATIONS

MOTOR	Horse Power	3/10
	Voltage	115 or 230
	Phase	1 Ph
	Hertz	60 Hz
	RPM	1550
	Type	Shaded pole
	Insulation	Class B
	Amps	4.8 - 9.7
PUMP	Operation	Automatic or nonautomatic
	Auto On/Off Points	7-1/4" (18.4 cm) / 3" (7.6 cm)
	Discharge Size	1-1/2" NPT
	Solids Handling	1/2" (12 mm) spherical solids
	Cord Length	9' (3 m) automatic, 15' (5 m) nonautomatic
	Cord Type	UL listed, 3-wire, grounded plug
	Max. Head	19.25' (5.9 m)
	Max. Flow Rate	43 GPM (163 LPM)
	Max. Operating Temp.	130 °F (54 °C)
	Cooling	Oil filled
	Motor Protection	Auto reset thermal overload
MATERIALS	Cap	Cast iron or bronze
	Motor Housing	Cast iron or bronze
	Pump Housing	Cast iron or bronze
	Base	Cast iron, bronze or engineered thermoplastic
	Upper Bearing	Sleeve bearing
	Lower Bearing	Sleeve bearing
	Mechanical Seals	Carbon and ceramic
	Impeller Type	Non-clogging vortex
	Impeller	Plastic, cast iron or bronze
	Hardware	Stainless steel
	Motor Shaft	AISI 1215 cold rolled steel
	Gasket	Neoprene

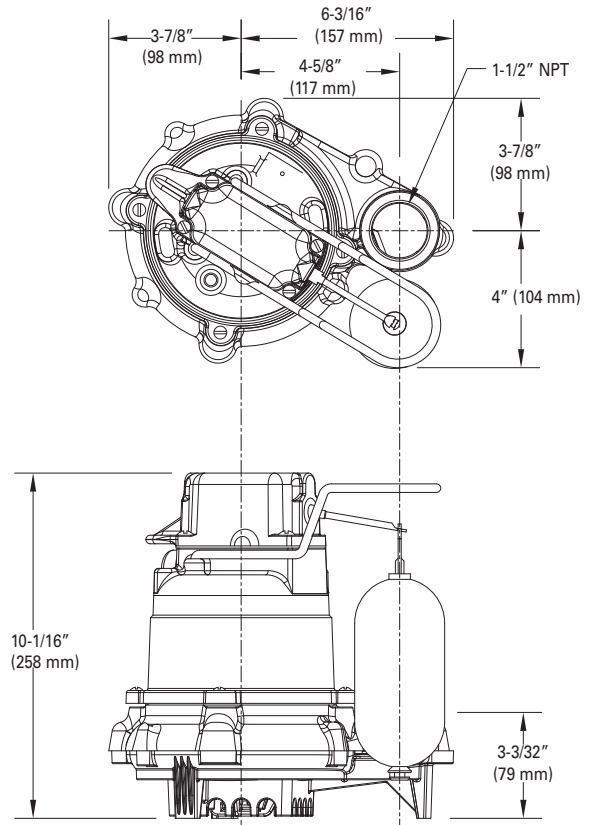

SK858

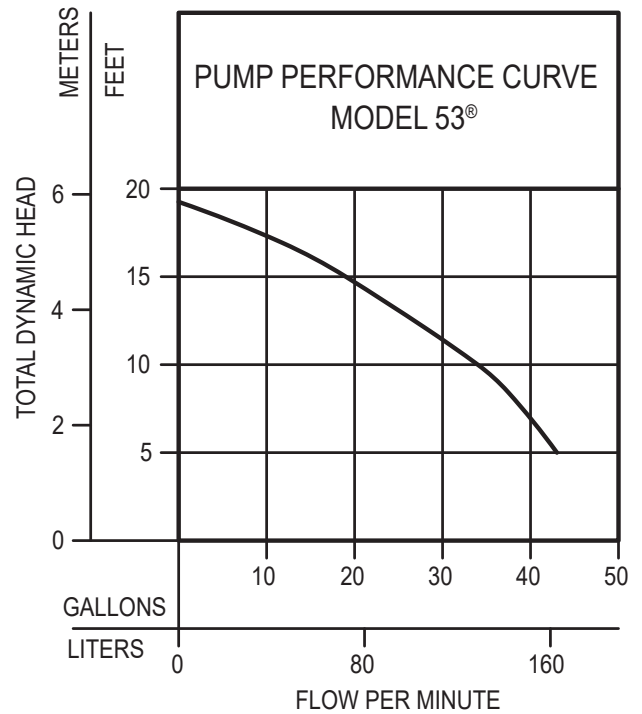

NOTE: See model comparison chart for specific details.



All installation of controls, protection devices and wiring should be done by a qualified licensed electrician. All electrical and safety codes should be followed including the most recent National Electrical Code (NEC) and the Occupational Safety and Health Act (OSHA).

