



TFTN085-110
High Efficiency Gas-Fired Condensing Boiler

SUBMITTAL SHEET
Section 1 – General Specifications
Section 2 – Product Dimensions
Section 3 – Field Wiring

Project Name: _____ Date: _____
Location: _____
Engineer: _____
Contractor: _____ Rep: _____

1 – GENERAL SPECIFICATIONS

Product Features:

- ✓ Certified to ANSI Z21.13 / CSA 4.9
- ✓ SA-240 S43932 Chromium SS Fire Tube Heat Exchanger
- ✓ ASME H-stamped as a heating boiler
- ✓ Maximum operating pressure 50 psi
- ✓ Wall mounted (floor mounting with optional kit)
- ✓ Zero clearance to combustibles (clearances required for service)
- ✓ Modulating burner, 10:1 turndown ratio
- ✓ Certified as Direct Vent or for use with indoor combustion air
- ✓ Sealed cabinet with integrated silencer and air-filter
- ✓ 7 in. touch screen display
- ✓ High energy ignition transformer (spark ignition)
- ✓ Integrated LWCO (UL353 certified)
- ✓ On/off power switch
- ✓ 120VAC convenience outlet
- ✓ WiFi remote connectivity embedded
- ✓ Integrated 3-Zone controller (3x CH inputs & outputs)
- ✓ DHW zone input (tank thermostat or sensor)
- ✓ Outdoor and 2x Auxiliary temperature sensor inputs
- ✓ 0-10V input for external temperature or burner power control
- ✓ Boiler, DHW and 2x Auxiliary pump outputs
- ✓ Variable speed pump output (0-10V / PWM)
- ✓ Boiler power output signal (0-10V)
- ✓ Alarm contact

Control Features:

- ✓ Integral microprocessor safety control – flame and temperature safeguard
- ✓ Fully adjustable burner test mode
- ✓ AUTO CH boiler temperature adjustment/reset (based on outdoor and/or indoor temperature or T-stat cycles)
- ✓ Adjustable reset curve (min-T/max-T/slope/offset)
- ✓ Adjustable reset temperature boost
- ✓ Summer/Winter changeover (WWSD)
- ✓ Integrated programmable T-stat x 3 (with optional NTI Room Sensors)
- ✓ Freeze protection (on/off settable)
- ✓ Settings backup & restore options
- ✓ Cascade up to 8 TFTN-series boilers
- ✓ Manual mode operation (pumps/fan/alarm)
- ✓ Boiler statistics
- ✓ Lockout, error and warning history
- ✓ Internet outdoor temperature via WiFi connection
- ✓ Adjustable delta-T control (w/ variable speed pump)
- ✓ Adjustable high limit (CSD-1 compliant)
- ✓ DHW recirculation with adjustable schedule
- ✓ Buffer tank charging function
- ✓ 3 independently adjustable CH zones
- ✓ Adjustable CH zone priority logic
- ✓ Adjustable DHW/CH priority switching logic
- ✓ Anti-legionella function
- ✓ Adjustable system pump activation logic
- ✓ Adjustable CH anti-cycle function
- ✓ Adjustable maintenance schedule/warning
- ✓ Optional NTI 3-Zone Pump/Valve Controller (expands zone control up to six – each independently adjustable)
- ✓ Optional NTI Room Sensor

Factory Supplied Items:

- ✓ Outdoor sensor
- ✓ 30 psi ASME pressure relief valve
- ✓ Pressure & temperature gauge
- ✓ LP conversion kit
- ✓ Vent screens

Model	Water Connections, NPT	Gas Connection, NPT	Vent/Air-Inlet Connection	Max. Vent/Air-Inlet Length	
				2" pipe	3" pipe
TFTN085-110	1-1/4" (Male)	3/4" (Male)	3 in. (PVC/CPVC/PP)	100 ft	150 ft

Performance Specifications

Model	Input Rating, MBH	Heating Capacity, MBH	Net AHRI Rating, Water MBH	AFUE %
TFTN085	8.5 - 85	79	69	96
TFTN110	11 - 110	101	88	95



NTI Boilers Inc.

NTI Boilers Inc. 30 Stonegate Drive, Saint John, NB E2H 0A4 Canada
Technical Services: 1-800-688-2575 Fax: 1-506-432-1135 Web: [http:// www.ntiboilers.com](http://www.ntiboilers.com)
NTI Boilers Inc. reserves the right to change these specifications without notice



TFTN085-110
High Efficiency Gas-Fired Condensing Boiler

SUBMITTAL SHEET
Section 1 – General Specifications
Section 2 – Product Dimensions
Section 3 – Field Wiring

2 – PRODUCT DIMENSIONS - in.

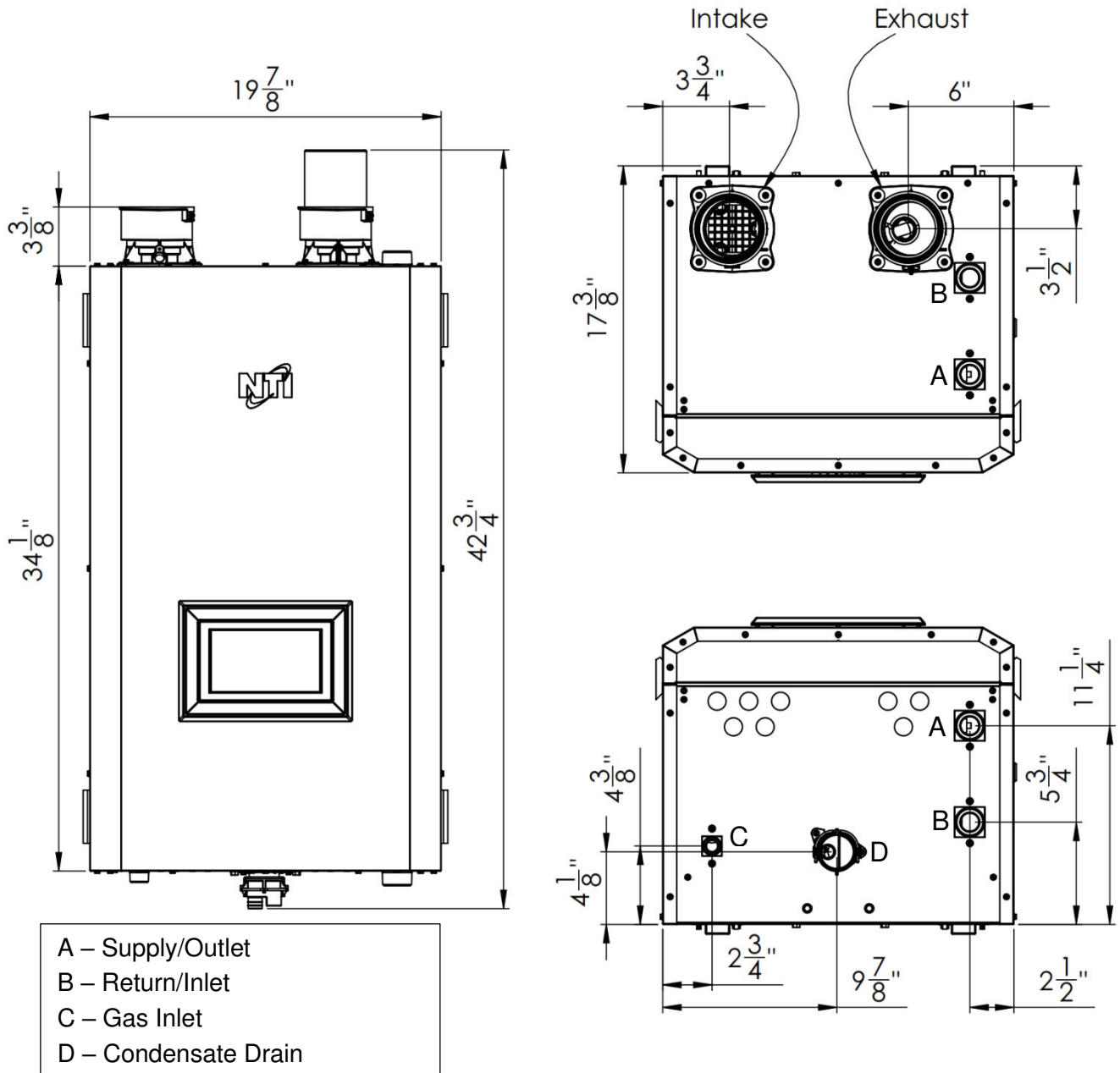

MINIMUM SERVICE CLEARANCES - in.

Front	Top	Sides	Back	Bottom	Flue Pipe
18	14	2	0	12	1



NTI Boilers Inc.

NTI Boilers Inc. 30 Stonegate Drive, Saint John, NB E2H 0A4 Canada
 Technical Services: 1-800-688-2575 Fax: 1-506-432-1135 Web: [http:// www.ntiboilers.com](http://www.ntiboilers.com)
 NTI Boilers Inc. reserves the right to change these specifications without notice



TFTN085-110 High Efficiency Gas-Fired Condensing Boiler

SUBMITTAL SHEET
Section 1 – General Specifications
Section 2 – Product Dimensions
Section 3 – Field Wiring

3 -- FIELD WIRING

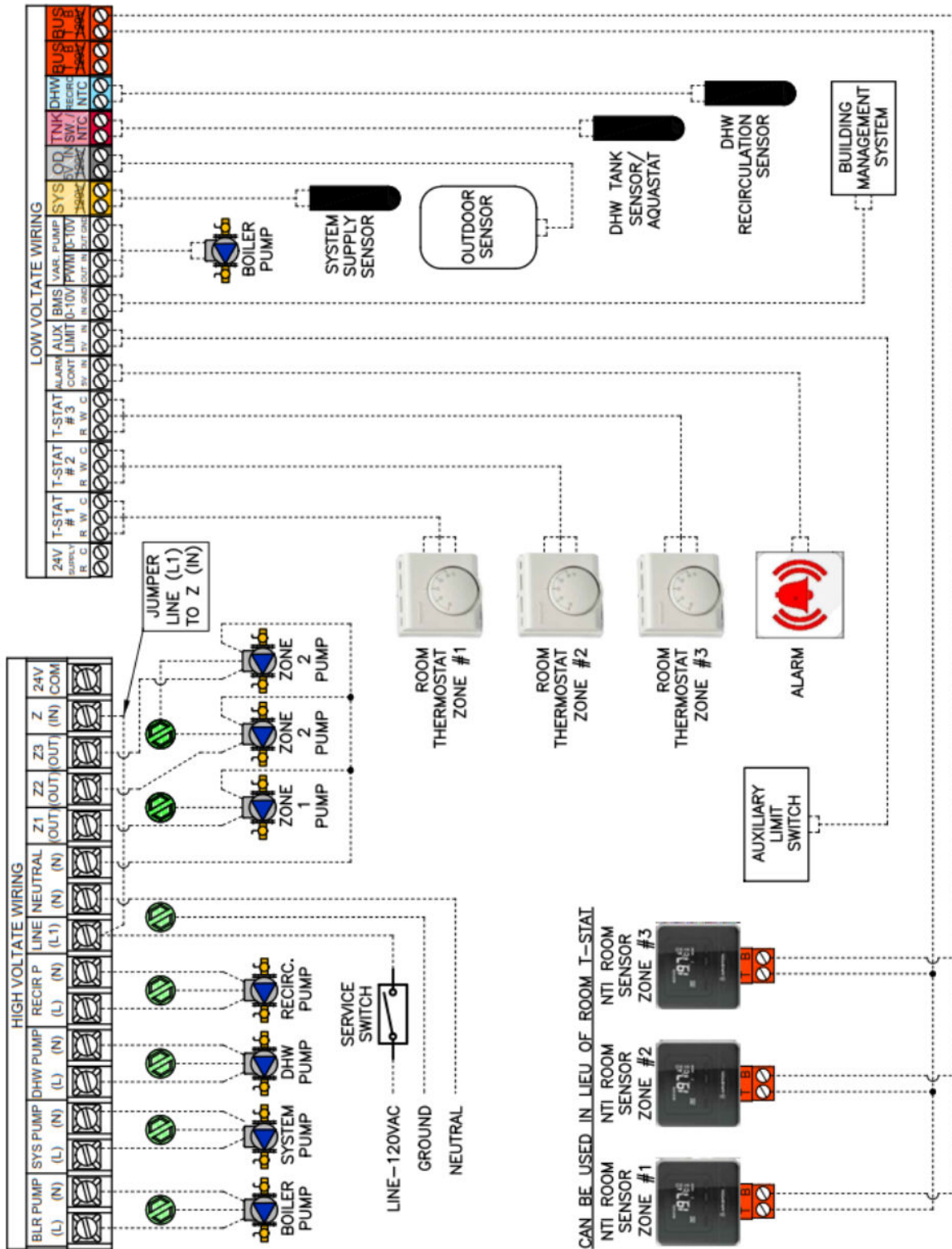

NTI Boilers Inc.

NTI Boilers Inc. 30 Stonegate Drive, Saint John, NB E2H 0A4 Canada
 Technical Services: 1-800-688-2575 Fax: 1-506-432-1135 Web: [http:// www.ntiboilers.com](http://www.ntiboilers.com)
 NTI Boilers Inc. reserves the right to change these specifications without notice