

13ACDL

PRODUCT SPECIFICATIONS

13 SEER NITROGEN CHARGED AIR CONDITIONER

FORM NO. 13ACDL-100 (09/2015)



- Nitrogen charged for replacement of R22 components only
- High-quality condenser coil with copper tubing and enhanced louvered fin for maximum heat transfer capacity
- Top discharge directs hot air away from living area and shrubbery
- All units factory run tested
- Available with louvered panel or wire guard coil protection
- Easy access to electrical panels
- Corner mounted service valves for easy hook-up and service
- All units UL and ULC approved

WARRANTY

5 year limited warranty on compressor, 5 year limited warranty on all parts

**Warranty provides for a total of 10 years of limited warranty coverage (Standard 5-year limited parts warranty plus an additional 5-year limited extended parts warranty). Warranty must be registered online within 60 days of installation to qualify for 10-year coverage. Unregistered equipment defaults to 5-year coverage. Lifetime limited heat exchanger warranty applies to registered equipment only (Standard 20 years with no online registration). See full warranty at www.alliedair.com for terms, conditions and exclusions.*



MODEL NUMBER GUIDE

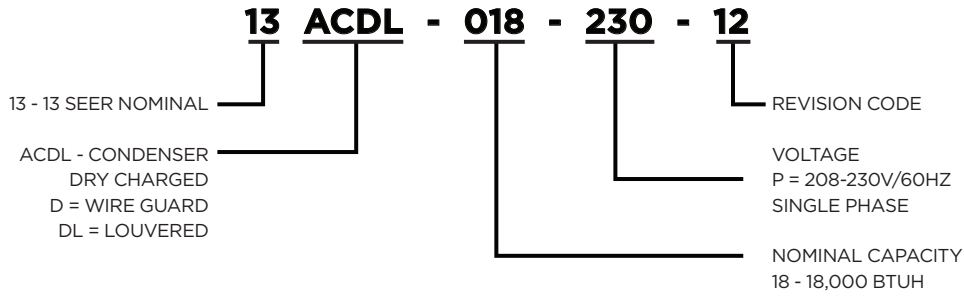

ELECTRICAL AND PHYSICAL DATA

Model	Voltage/ Hz/ Phase	Voltage Range	Min. Circuit (Amps)	Max. Fuse (Amps) [†]	Compressor		Outdoor Fan Motor			"Field Supplied R22 Charge (oz.)"	Shipping Weight (lbs.)	
					Rated Load (Amps)	Locked Rotor (Amps)	Full Load (Amps)	Rated HP	Nom. RPM		Wire Guard	Louvered
13ACDL018	208-230/60/1	197-253	10.4	15	7.7	40	0.7	1/10	1075	61	117	125
13ACDL024	208-230/60/1	197-253	13.7	20	10.4	54	0.7	1/10	1075	67	118	126
13ACDL030	208-230/60/1	197-253	18.8	30	14.1	67	1.1	1/5	1075	77	136	147
13ACDL036	208-230/60/1	197-253	19.1	35	14.4	77	1.1	1/5	1075	92	136	147
13ACDL042	208-230/60/1	197-253	25.7	40	19.2	104	1.7	1/4	825	102	165	177
13ACDL048	208-230/60/1	197-253	25.7	40	19.2	97	1.7	1/4	825	120	184	206
13ACDL060	208-230/60/1	197-253	33.3	60	26.1	141	1.7	1/4	825	160	206	213

[†] Overcurrent protection device
^{††} Factory charge adequate for 15 feet of line set. Adjust per Installation Instructions.

UNIT DIMENSIONS & SOUND RATINGS

Model	Dimensions			Sound Ratings (dBa)
	A - width (in.)	B - depth (in.)	C - height (in.)	
13ACDL018	24.25	24.25	25.25	76
13ACDL024	24.25	24.25	25.25	76
13ACDL030	24.25	24.25	33.25	76
13ACDL036	24.25	24.25	33.25	76
13ACDL042	28.25	28.25	29.25	79
13ACDL048	28.25	28.25	37.25	79
13ACDL060	28.25	28.25	33.25	79

Note: Dimensions listed are unit sizes w/o packaging

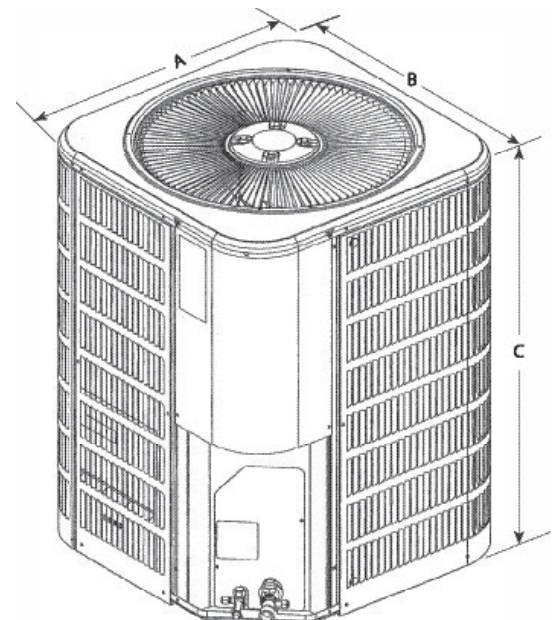

COOLING PERFORMANCE WITH EVAPORATOR COILS

Outdoor Model	Indoor Model	SEER	EER	Rated AHRI ¹ Capacity	Rated Sensible Capacity	CFM	Refrigerant Connection				Refrigerant Line Size		Indoor Metering Device	
	Evaporator Coil ³ or Air Handler ³						Outdoor		Indoor		Suction	Liquid	Piston ²	TXV
							Suction	Liquid	Suction	Liquid				
13ACDL018	E(U,C,M,H)1P18A,B+TDR	13.0	11.0	17,700	13,600	600	3/4	3/8	3/4	3/8	3/4	3/8	0.055	A2TXV01
13ACDL024	E(U,C,M,H)1P24A,B+TDR	13.0	11.0	23,400	18,700	800	3/4	3/8	3/4	3/8	3/4	3/8	0.062	A2TXV01
13ACDL030	E(U,C,M,H)1P24A,B+TDR	13.0	11.0	28,000	21,300	900	3/4	3/8	3/4	3/8	3/4	3/8	0.067	A2TXV01
13ACDL036	E(U,C,M,H)1P36B,C+TDR	13.0	11.0	35,000	27,700	1200	7/8	3/8	3/4	3/8	7/8	3/8	0.076	A2TXV01
13ACDL042	E(U,C,M,H)1P43B,C+TDR	13.0	11.0	41,500	32,400	1400	7/8	3/8	7/8	3/8	7/8	3/8	0.080	A2TXV02
13ACDL048	E(U,C,M,H)1P50C+TDR	13.0	11.0	45,500	35,500	1600	7/8	3/8	7/8	3/8	7/8	3/8	0.089	A2TXV02
13ACDL060	E(U,C,M,H)1P50C+TDR	13.0	11.0	58,000	44,100	1750	1-1/8	3/8	7/8	3/8	1-1/8**	3/8	0.099	H2TXV03

*Units are factory shipped with dry nitrogen holding charge.

**Suction valve size is 7/8"; field supplied 7/8" to 1-1/8" adapter required. Use of 7/8" Vapor line reduces performance.

Note:

EPA rules prohibit system installations (condensing unit coupled with an air handler or evaporator coil)

ACCESSORIES

CATALOG / KIT NUMBER	DESCRIPTION	WHERE USED
58M81	Blower Off Delay Kit	All 13ACDL's
69J03	Compressor Sound Covers	
45F08	Compressor Low Ambient Cut-Off	
93G35	Freezestats (3/8" tubing)	
50A93	Freezestats (5/8" tubing)	
94J46	High Pressure Switch Kit (AC only)	
84M23	Loss of Charge Kit (AC only)	
47J27	Compressor Time Off Control (AC only)	
24H77	Low Ambient (AC - R22)	
93M04	Crank Case Heater - CCH	
93M05		3-1/2, 4 & 5 Ton
10J42	Hard Start Kit	1-1/2, 2, 2-1/2, 3, 3-1/2 & 4 Ton
81J69	Hard Start Kit	5 Ton Only
H2TXV03	TXV Kit	
A2TXV01		
A2TXV02		3-1/2 & 4 Ton



1-800-448-5872

All specifications and illustrations subject to change without notice and without incurring obligations.