

# KEEP IT CLEAN!

Protects Environment & Equipment  
From The Dispersion Of Oils and/or Hydrocarbons

## Oil Guard<sup>®</sup> System

- Independently verified by OnSpeX, div. of CSA, when installed in accordance with our instructions
- Applications include elevator sumps, transformer vaults and manufacturing facilities
- Designed, Machined & Assembled in USA

100% factory tested



**ZOELLER**<sup>®</sup>   
PUMP COMPANY

Trusted. Tested. Tough.<sup>®</sup>

zoellerpumps.com 800-928-7867  
3649 Cane Run Road, Louisville, KY 40211 USA

FM3064  
0821  
Supersedes  
0420

## MODEL 57

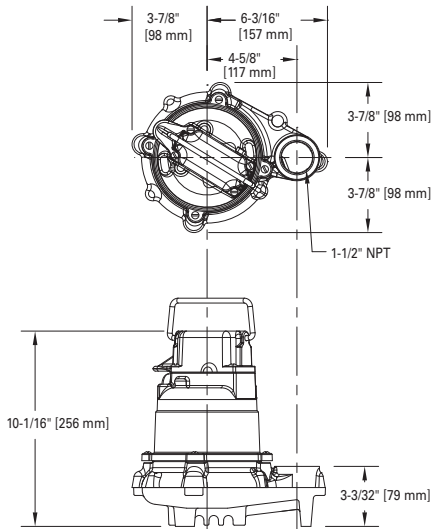

## MODEL 152/153

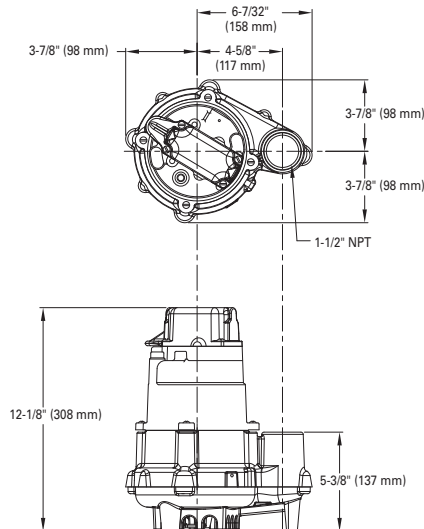

## MODEL 161

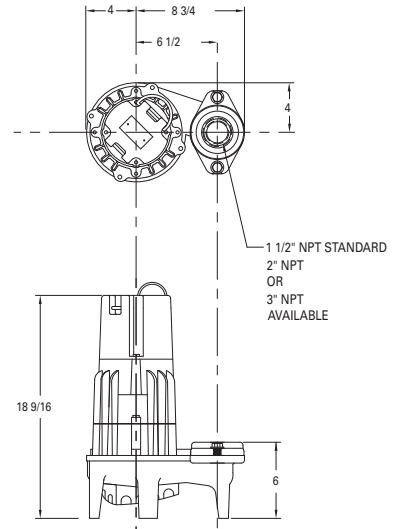

See FM2778 (Model 57,) FM2784 (Models 152/153), FM2785 (Model 161) for complete pump specifications

## CHOOSE A PREPACKAGED SYSTEM

Part Number	Description	Alarm Panel	Oil Smart® Pump Switch	Nonautomatic Pump	Pump Part Number	Volts	HP	Amps	Elevator System
940-005	Oil Guard® Pump Switch and Panel	10-1526	10-1528	N57	57-0002	115	3/10	9.7	N
940-006	Oil Guard® Pump Switch and Panel	10-1526	10-1528	N152	152-0002	115	4/10	8.5	N
940-007	Oil Guard® Pump Switch and Panel	10-1526	10-1528	N153	153-0002	115	1/2	10.5	N
940-008	Oil Guard® Pump Switch and Panel	10-1526	10-1528	N161	161-0002	115	1/2	15.0	N
940-0012	Oil Guard® Pump Switch and Panel	10-1526	10-1528	*N152	*152-0028	115	4/10	8.5	Y
940-0013	Oil Guard® Pump Switch and Panel	10-1526	10-1528	*N153	*153-0027	115	1/2	10.5	Y
940-0014	Oil Guard® Pump Switch and Panel	10-1526	10-1528	*N161	*161-0090	115	1/2	15.0	Y

\* 6' (1.8 m) SO jacketed cord for oil resistance.

## OR BUILD YOUR OWN SYSTEM

Part Number	Description	Alarm Panel	Oil Smart® Pump Switch	Oil Smart® High Liquid Alarm Switch	Oil Smart® High Liquid Switch
10-1526	Oil Smart® Alarm Panel	√	---	√	---
10-1528	Oil Smart® Pump Switch	---	√	---	---
10-1727	Oil Smart® Pump Switch w/o Plug	---	√	---	---
10-2149	Oil Smart® Simplex Panel	√	√	√	---
10-2150	Oil Smart® Duplex Panel	√	√	√	√
10-2516	Oil Smart® Simplex Panel w/ Mtr.	√	√	*	---

√ INCLUDED \* VARIABLE LEVEL FLOAT SWITCH

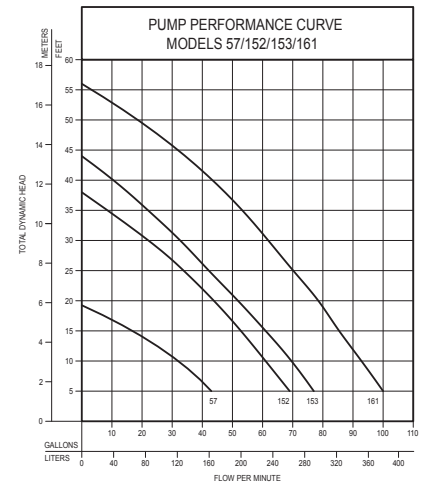

### SIMPLEX PANEL

- 115V, single phase
- NEMA 4X watertight enclosure w/ lockable latch
- 30 amp motor start relay
- Pump HOA switch
- Top-mounted red alarm beacon light
- 81 - 84 decibel rated alarm horn
- Horn silence and alarm test switches
- Alarm automatically resets
- Dry auxiliary alarm contacts
- Separate circuit protection for alarm
- Circuit breaker protection
- Pump "Run" indicator light



Model 10-2149

### DUPLEX ALTERNATING PANEL

- 115V, single phase
- NEMA 4X watertight enclosure w/ lockable latch
- (2) 30 amp motor start relays
- Pump HOA switches
- Top-mounted red alarm beacon light
- 81 - 84 decibel rated alarm horn
- Horn silence and alarm test switches
- Alarm automatically resets
- Dry auxiliary alarm contacts
- Separate circuit protection for alarm
- Pump "Run" indicator light



Model 10-2150

© Copyright 2021 Zoeller® Co. All rights reserved.

502-778-2731 | 800-928-7867 | 3649 Cane Run Road | Louisville, KY 40211-1961 | zoellerpumps.com