

AIR ADMITTANCE VALVE with ACCESS BOX

696 series

TurboVent™

SPECIFICATION

Sioux Chief 696 series TurboVent air admittance valves with access box shall be installed as vent terminal for secondary venting within the plumbing system. Valve shall connect to DWV system via Sch. 40 adapter which complies with ASTM D2665 (PVC) or D2661 (ABS), and be made accessible after finish wall is installed. Valve shall incorporate an actuating device which spins upon activation to keep the elastomeric sealing surface clean and free of debris. During drainage, actuating device shall raise a designed distance under negative line pressure to allow optimal air flow into the DWV system. Valve shall provide a positive seal at 0 psi and under any positive line pressure to prevent sewer gasses from entering the living space. Valve shall be made in USA, comply with IPC model code and be certified to ASSE 1050 and 1051 standards.

MATERIALS

- valve housing/thread body: ABS (white)
- actuating device: ABS
- sealing member: elastomer
- thread x hub adapter: ABS or PVC
- access box: ABS (white)
- box frame: ABS (white)
- louvered frame insert: ABS (white)

DFU RATING

- stack: 24 (drainage fixture units)
- branch: 160 (drainage fixture units)

DIMENSIONS

- A: overall valve width 2 1/16"
- B: overall valve height 2 1/8"
- C: thread size 2" NPT
- D: open grate area 1.134 in²
- E: adapter height 1 3/4"
- F: box rough-in width 4"
- G: box rough-in height 5 1/2"
- H: pipe access hole 2 3/8"
- I: frame width 5 3/4"
- J: frame height 7 1/4"

CODES & STANDARDS

- certified by ASSE to 1050 & 1051
- listed by IAPMO
- adapters conform to ASTM D2661/D2665/F409
- conforms to International Plumbing Code (IPC) 2009
- conforms to International Residential Code (IRC) 2009
- conforms to Uniform Plumbing Code (UPC) 2009 section 301.2

Item # Submitted _____
Job Name _____
Location _____
Engineer _____
Contractor _____
PO# _____ TAG _____

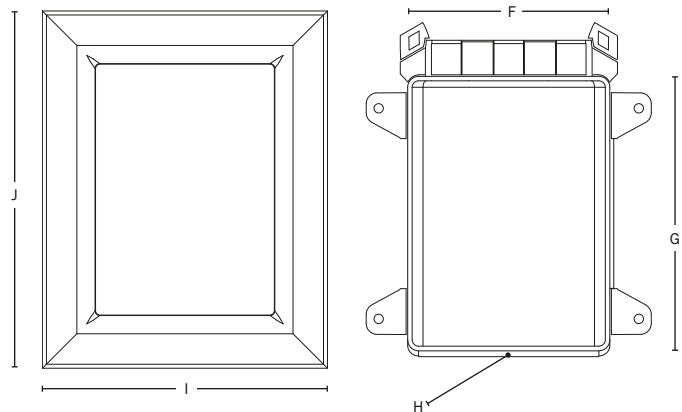
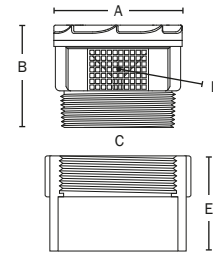

Create Item Number

696-A

e.g. 696-12P = TurboVent valve with access box, frame and louvered insert – 2" PVC thread x hub adapter

- A** CONNECTION TYPE
- 12A** 2" ABS thread x hub adapter
- 12P** 2" PVC thread x hub adapter