

SharkBite EvoPEX™

Reducing Tee

SharkBite™ EvoPEX fittings are designed for use with PEX and PE-RT tubing and are engineered as a more efficient alternative to tool-based pipe joining methods. Made in the USA, SharkBite EvoPEX fittings have a 25-year system warranty when used with SharkBite PEX tubing. SharkBite EvoPEX fittings are permanent connections, can be rotated after assembly and have a green indicator ring that confirms the proper tubing installation depth.

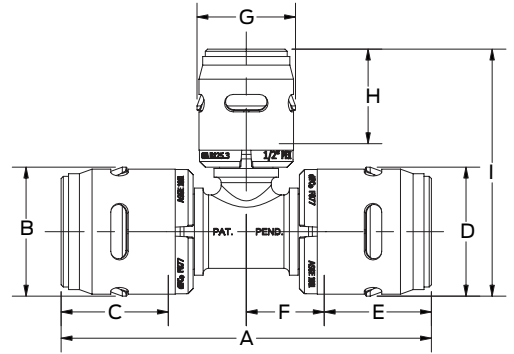

Approved Applications

Residential and commercial potable water, recirculation, hydronic heating/cooling (up to 100% glycol concentration) and direct burial.

Dimensions (inches)

Part Number	Size	A	B	C	D	E	F	G	H	I
K408	1/2" x 1/2" x 3/4"	3.29	0.89	0.83	0.89	0.83	0.81	1.16	0.94	2.19
K412	3/4" x 3/4" x 1/2"	3.34	1.16	0.94	1.16	0.94	0.72	0.89	0.83	2.23
K413	3/4" x 3/4" x 1"	3.83	1.16	0.94	1.16	0.94	0.97	1.46	1.10	2.67
K414	1" x 3/4" x 3/4"	3.84	1.46	1.10	1.16	0.94	0.86	1.16	0.94	2.65
K415	1" x 1" x 1/2"	3.85	1.46	1.10	1.46	1.10	0.81	0.89	0.83	2.52
K416	1" x 1" x 3/4"	4.05	1.46	1.10	1.46	1.10	0.92	1.16	0.94	2.65
K418	1" x 3/4" x 1"	4.06	1.46	1.10	1.16	0.94	0.98	1.46	1.10	2.86
K419	1" x 3/4" x 1/2"	3.74	1.46	1.10	1.16	0.94	0.87	0.89	0.83	2.52
K444	3/4" x 1/2" x 3/4"	3.46	1.16	0.94	0.89	0.83	0.85	1.16	0.94	2.35
K454	3/4" x 1/2" x 1/2"	3.25	1.16	0.94	0.89	0.83	0.75	0.89	0.83	2.23

Specification Data

Materials

Body	Modified PPSU
Collet	Glass Reinforced Nylon
Grab Ring	SST 316
Spacer Ring	Acetal Copolymer
Collet Retainer	SST 304
Protection Ring	Glass Reinforced Nylon
Radial Seal	EPDM

Pipe Insertion Depth

Fitting Size	Insertion Depth
1/2 in.	0.83 in.
3/4 in.	0.94 in.
1 in.	1.10 in.

Performance

Max Working Pressure		
80 psi	at	200°F
100 psi	at	180°F
160 psi	at	73.4°F

Fitting Type	Wrap Required	
	Direct Burial	Embedded in Concrete
EvoPEX Fitting with Brass Bodies	Yes	Yes
EvoPEX Fitting without Brass Bodies	No	Yes

For more information about EvoPEX fittings, including application of wrap, please visit SharkBite.com

Certifications & Listings

ASSE 1061, CSA B137.5, ASTM F877, NSF/ANSI 14, NSF/ANSI/CAN 61, NSF/ANSI/CAN 372, ASTM E84, CAN/ULC S102.2, ASTM E119, CAN/ULC S101



Flame Spread Rating ≤ 25, Smoke Developed Rating ≤ 50 (FSI ≤ 25 / SDI ≤ 50)

US 1 877 700 4242 | sales@sharkbite.com | sharkbite.com
 Canada 1 888 820 0120 | canadasales@rwc.com

Product Submittal	
Name	
Date	
Architect/Owner	
Contractor	
Tag	
Notes	

