

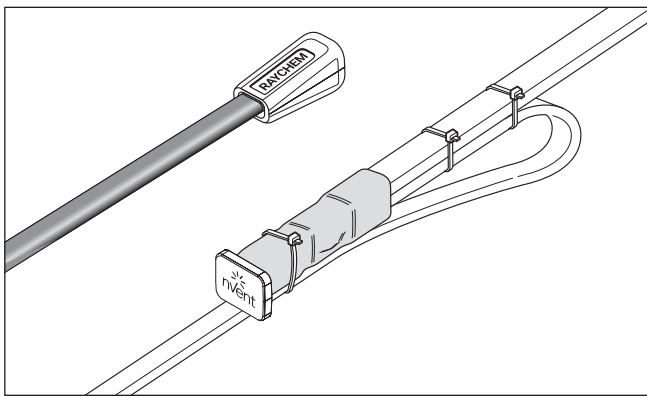

RAYCHEM

H910

WinterGard Splice and Tee Kit with End Seal Installation Instructions



DESCRIPTION

The nVent RAYCHEM WinterGard H910 Splice and Tee Kit is for use with WinterGard self-regulating heating cables to make splice, tee, and end seal connections. The kit contains materials for one splice and one end seal, or one tee connection and one end seal. This kit does not provide a power connection; use an nVent RAYCHEM H900 or H908 power connection kit for a complete installation.

APPLICATIONS

Use the H910 kit with the following nVent RAYCHEM WinterGard heating cables: H311, H611, H612, H621, and H622. All are designed for pipe freeze protection in dry locations, but H612 and H622 cables are designed for both wet and dry areas, as well as for roof and gutter de-icing. The cable type is printed on the outer jacket of the cable.

APPROVALS



TOOLS REQUIRED

- Diagonal cutters
- Utility knife
- Crimp tools (Ideal 30-429 and T&B WT112M or WT2000)
- Hammer and nail (for gutter/downspout applications only)
- Needle nose pliers
- Heat gun or torch

INSTALLATION AND SUPPORT

The minimum installation temperature for this kit is 0°F (-18°C). See the WinterGard Application and Design Guide (H53585), H900, or H908 installation instructions for design information. For additional technical support call nVent at (800) 545-6258.

KIT CONTENTS

Item	Qty	Description
A	2	Insulated bus wire crimps
B	1	Uninsulated braid crimp
C	3	Cable ties
D	8	Mastic strips
E	1	End plug
F	1	Heat-shrinkable tube (5 inch long, 1.5 inch diameter)
G	2	Black cloth tapes (6 inch long)
H	1	Clamp tie
I	1	End seal

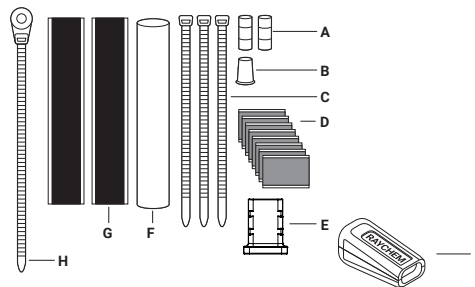

WARNING:

This component is an electrical device that must be installed correctly to ensure proper operation and to prevent shock or fire. Read these important warnings and carefully follow all the installation instructions.

- To minimize the danger of fire from sustained electrical arcing if the heating cable is damaged or improperly installed, and to comply with the requirements of nVent, agency certifications, and national electrical codes, ground-fault equipment protection must be used. Arcing may not be stopped by conventional circuit breakers.

- Bus wires will short if they contact each other. Keep bus wires separated.
- Keep components and heating cable ends dry before and during installation.
- The black heating cable core is conductive and can short. It must be properly insulated and kept dry.
- Component approvals and performance are based on the use of nVent-specified parts only. Do not use substitute parts or vinyl electrical tape.
- Leave these instructions with end user for reference and future use.

CAUTION:

HEALTH HAZARD: Overheating heat-shrinkable tubes will produce fumes that may cause irritation. Use adequate ventilation and avoid charring or burning. Consult SDS at nVent.com for further information.

CHEMTREC 24-hour emergency telephone:
(800) 424-9300

Non-emergency health and safety information:
(800) 545-6258.



RAY3122



ITCSN

Splice or Tee Connections

The instructions are shown for a tee connection. Splice connections are done the same way, without the third heating cable section.

HEATING CABLE CONSTRUCTION

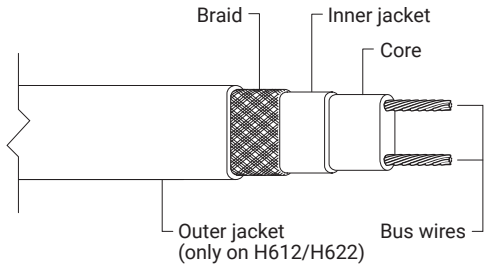

WinterGard Heating Cables

1

- Allow 12 in of extra heating cable as shown. If necessary trim cables evenly.

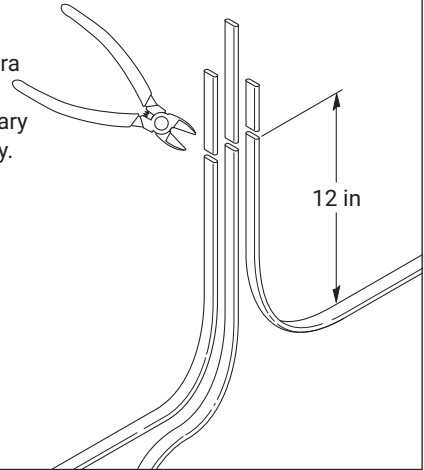

2

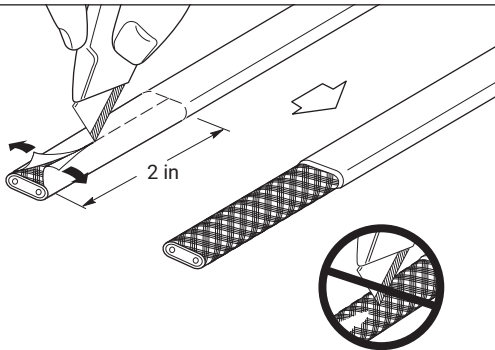

- H311, H611 and H621 do not have an outer jacket. Proceed to Step #3.
- Lightly score completely around and then down outer jacket.
- Bend heating cable to break jacket at score then peel off outer jacket.

Do not cut braid or inner jacket.

3

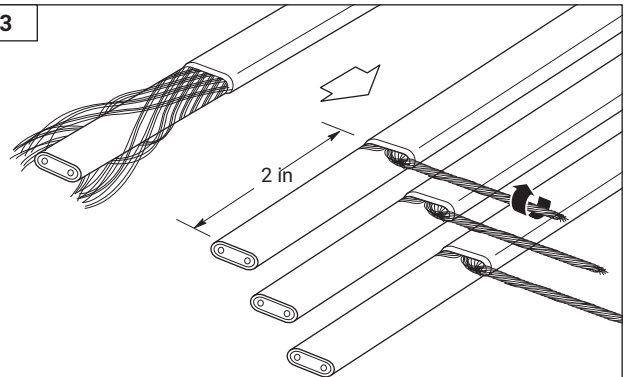

- For H612 and H622, unravel the braid back to the outer jacket. For H311, H611 and H621, unravel the braid back 2 inches.
- Position braid on same side of each heating cable section.
- Straighten the braid and twist into a "pigtail".

4

- At the end of each heating-cable section lightly score completely around and down inner jacket.

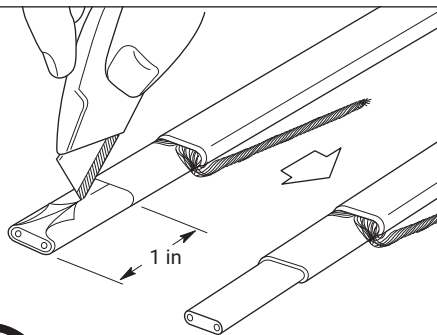

Do not cut bus wires.

- Bend heating cable to break jacket at score, then peel off inner jacket.

5

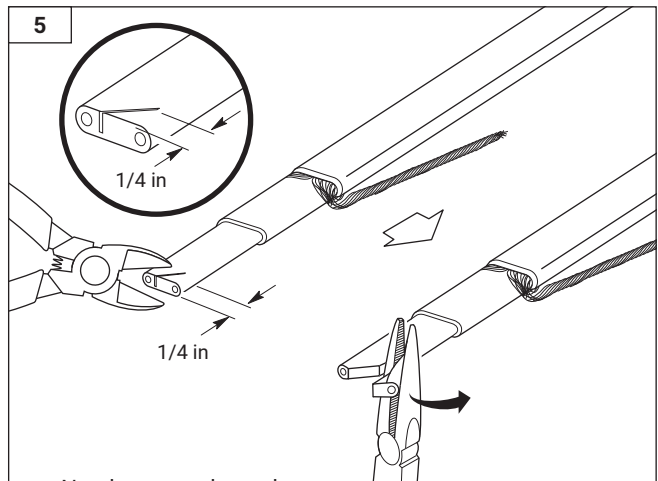

- Notch core at the end.
- Twist back and peel bus wires from core.

6

- Score between bus wires at base jacket.
- Bend core to break free at base jacket.



Do not cut bus wires.

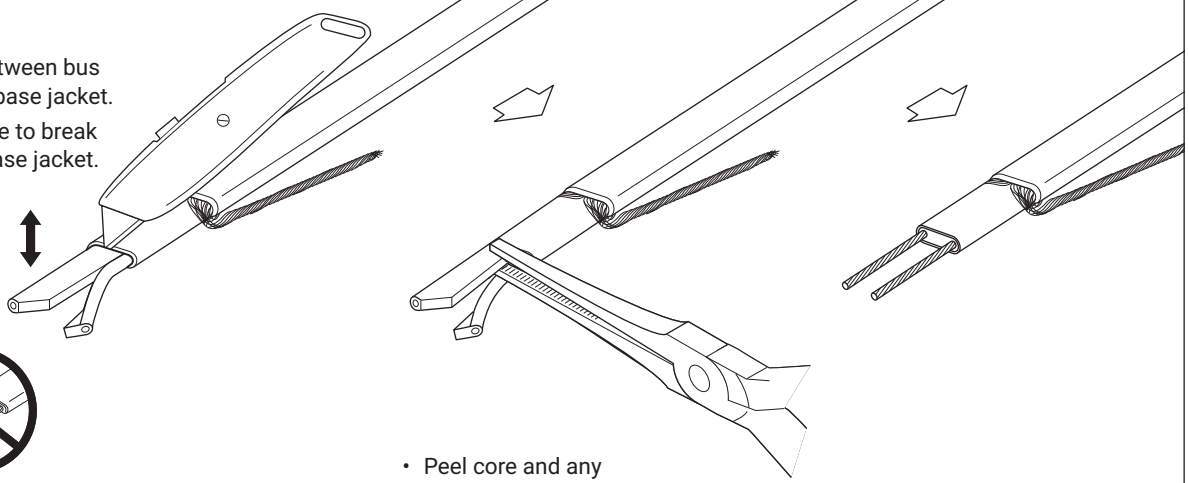

- Peel core and any remaining material from bus wires.

Repeat steps 2 through 6 for other heating cable sections.

7

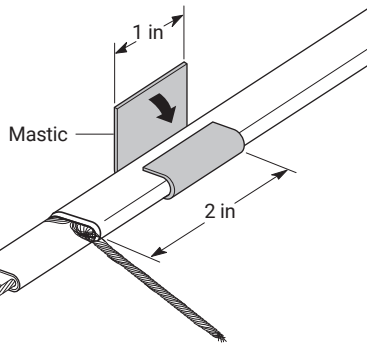

- Use clean gloves.
- Remove release paper from mastic strip.
- Don't let dirt or particles get into mastic.
- Wrap a piece of mastic around the outer jacket on each heating cable section.

8

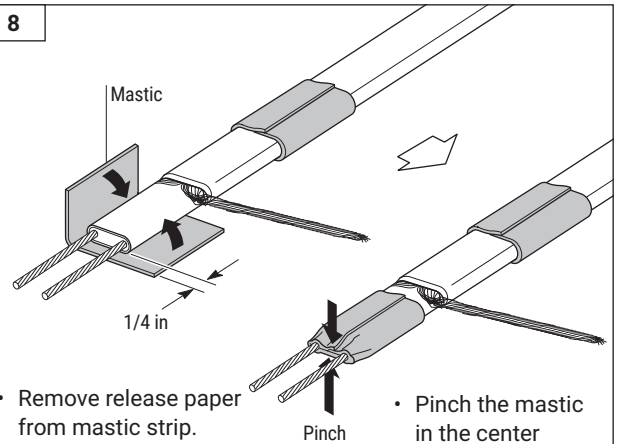

- Remove release paper from mastic strip.
- Wrap a piece of mastic around the end of each heating cable section and position as shown.
- Pinch the mastic in the center to completely seal the core at the end of each heating cable.

9

- Carefully align the heating cable sections and place them together.
- Press mastic strips firmly together.

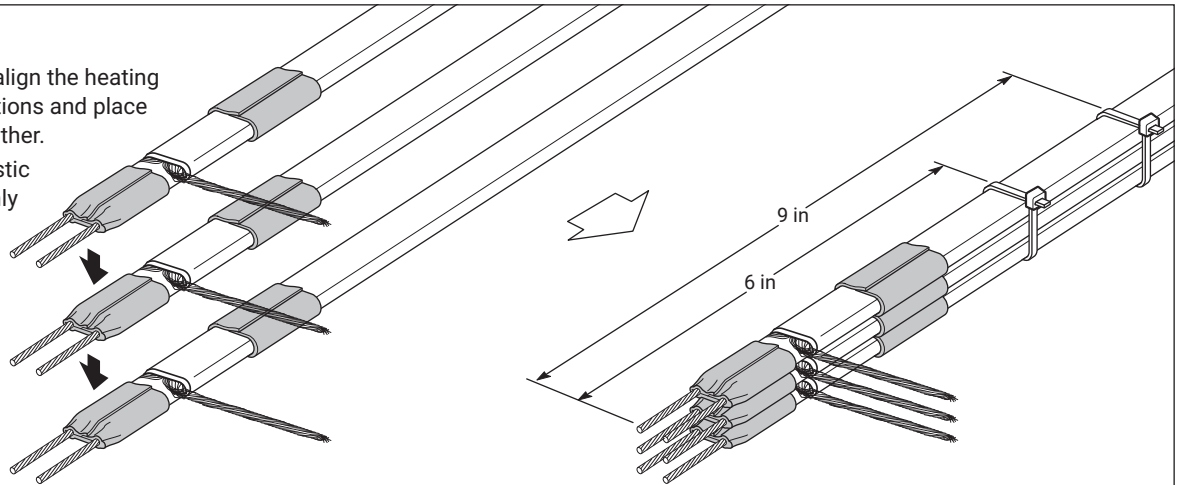

- Fasten with a cable tie at each of the two positions shown.

10

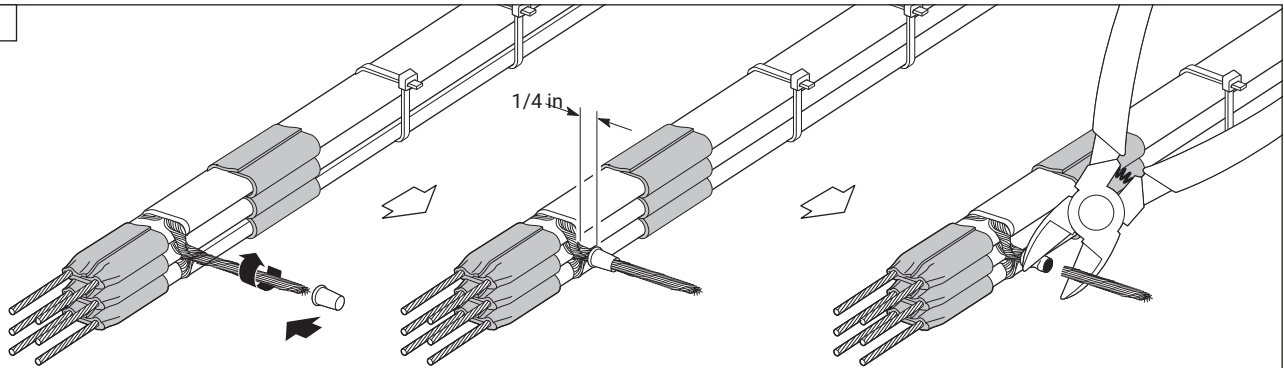

- Twist the braid pigtails together firmly.
- Slide insulated crimp over braid to within 1/4 inch of heating cable as shown.
- Crimp the braid, using the Ideal crimp tool.
- Crimp firmly to ensure the crimp is not loose.
- Cut off the extra braid.

11

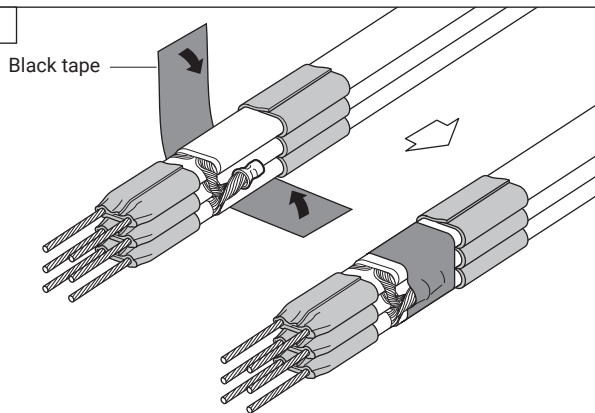

- Fold the crimped braid back against the heating cables.
- Wrap black cloth tape evenly around crimp and heating cables. Cover crimp completely.

CAUTION: Ensure flat surface of crimp touches cables in order to have a less bulky shape.

12

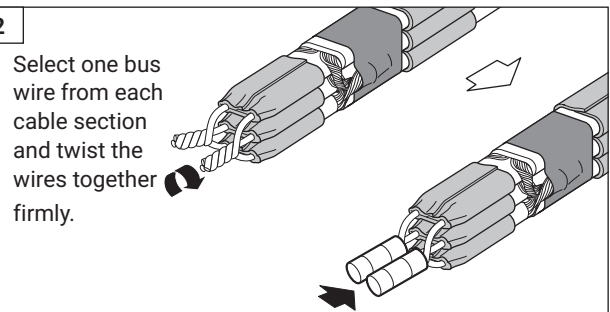

- Select one bus wire from each cable section and twist the wires together firmly.
- Repeat with remaining bus wires.
- **Be careful not to twist together bus wires from the same heating cable.**
- Use insulated bus wire crimps and T&B crimp tool (Insulated cavity section) to crimp each set of bus wires together firmly to ensure crimps are not loose.

CAUTION: Ensure there is no visible damage to the insulation layer of two crimps. After crimping, pull on crimp connection to check tightness.

13

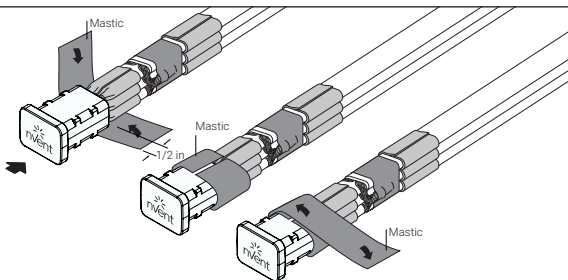

- First check that there are no cracks or damage to the end plug. Slide the end plug over the bus wire crimps all the way and push firmly toward mastic.
- Wrap one piece of mastic around the open end of the end plug so half of the width covers the end of plug and half covers the cables.
- Apply a second piece of mastic like the first one to completely cover the end of the plug. Press the mastic pieces together and into the plug and wire mastic pieces.

14

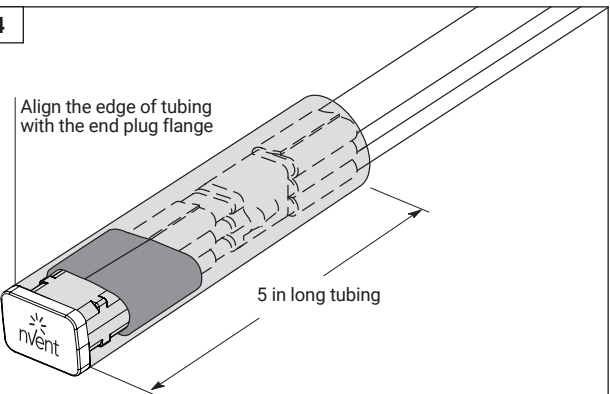

- Slide in the 5" heat shrink tube and align it with the flange of end plug, then start heating by a heat gun from the end plug toward the cables.

15

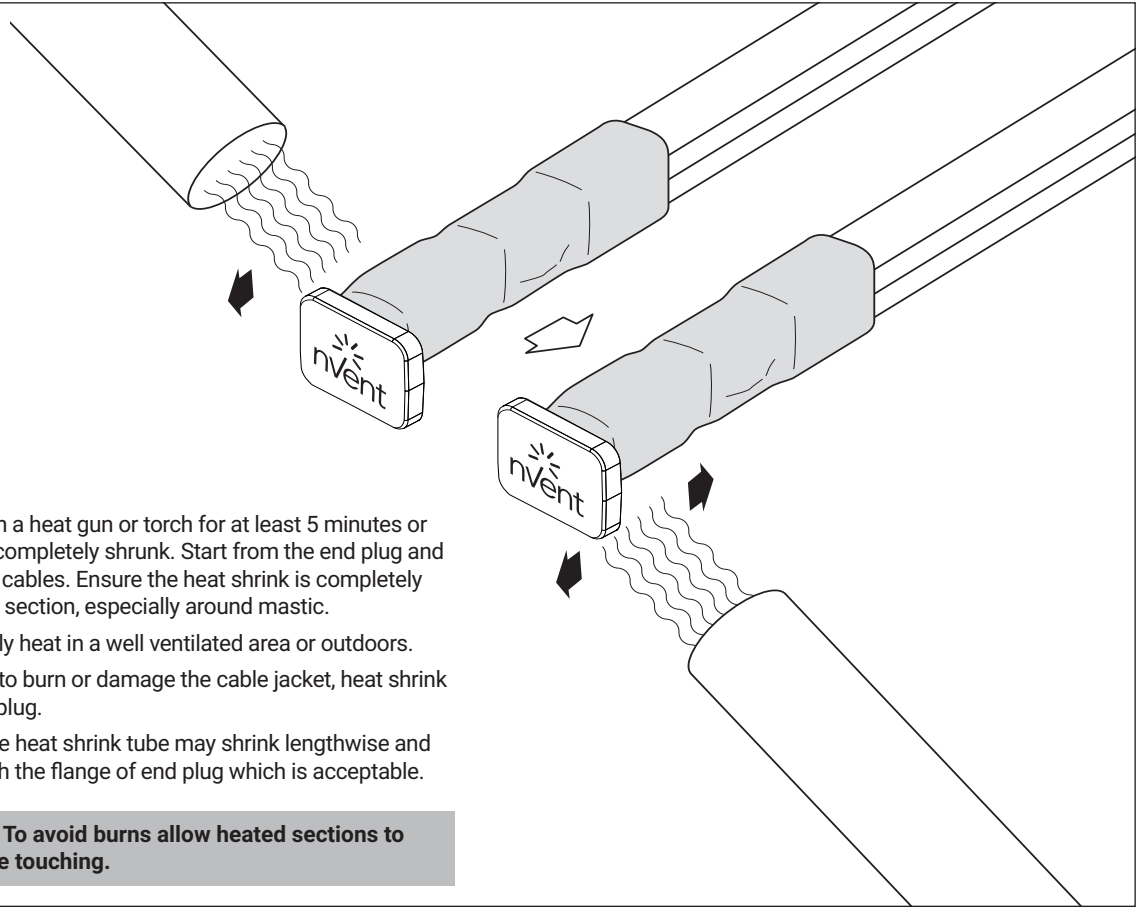

- Apply heat with a heat gun or torch for at least 5 minutes or until tubing is completely shrunk. Start from the end plug and move towards cables. Ensure the heat shrink is completely shrunk in each section, especially around mastic.
- Preferably apply heat in a well ventilated area or outdoors.
- Be careful not to burn or damage the cable jacket, heat shrink tubing, or end plug.
- The edge of the heat shrink tube may shrink lengthwise and have a gap with the flange of end plug which is acceptable.

CAUTION: To avoid burns allow heated sections to cool before touching.

16A For applications except WinterGard Wet in gutters and downspouts.

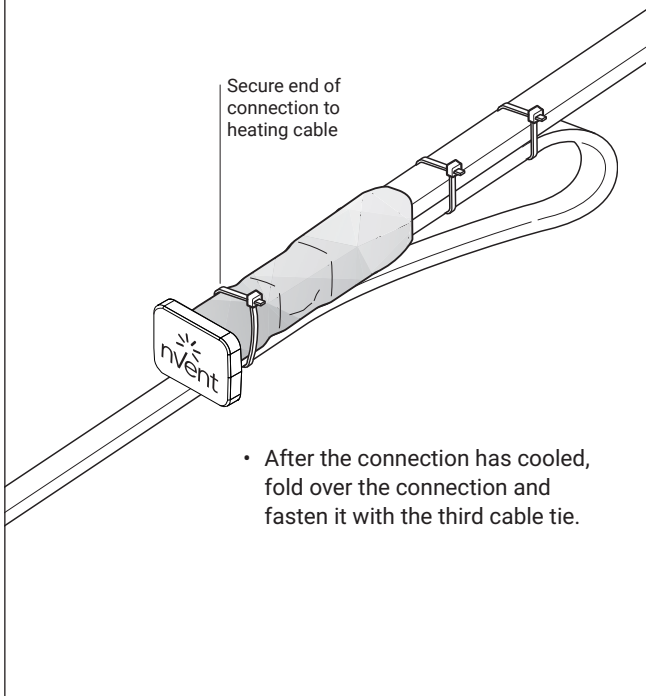

- After the connection has cooled, fold over the connection and fasten it with the third cable tie.

16B WinterGard Wet gutter and downspout applications.

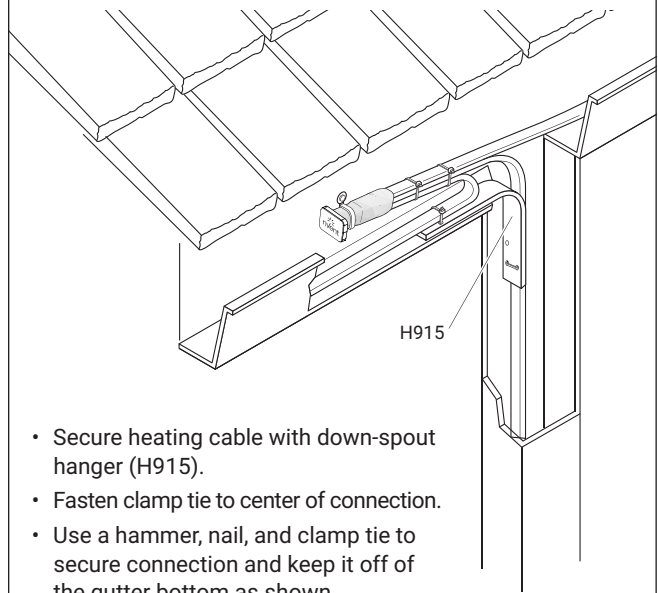

- Secure heating cable with down-spout hanger (H915).
- Fasten clamp tie to center of connection.
- Use a hammer, nail, and clamp tie to secure connection and keep it off of the gutter bottom as shown.

CAUTION: For cleaning, first disconnect the power, and cover the splice area before washing. Preferably avoid pressure washing on the splice area.

End Seal Installation Instructions for H612 and H622 Heating Cables

Note: The end seal is designed to be installed only once. It cannot be removed from the heating cable once it is installed. Do not install it until instructed to do so in Step 3

1

- Cleanly cut off the end of the cable.
- Score down and around outer jacket 1 inch from the end.
- Remove the outer jacket.
- Do not cut or damage inner jacket.

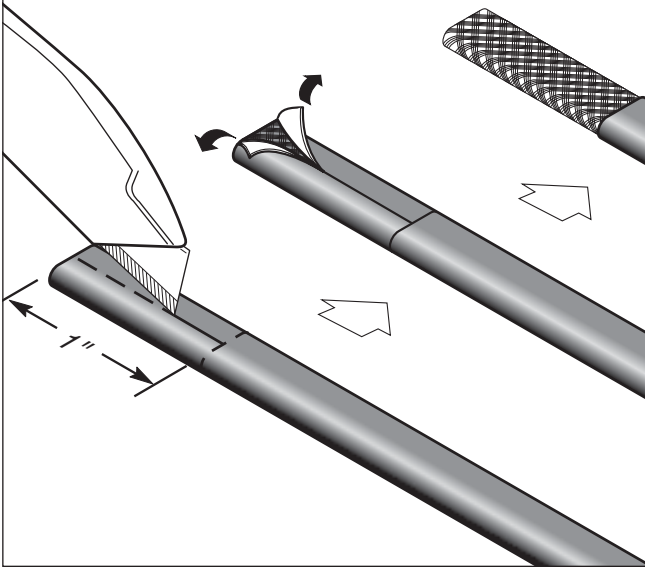

2

- Unravel and remove exposed braid.

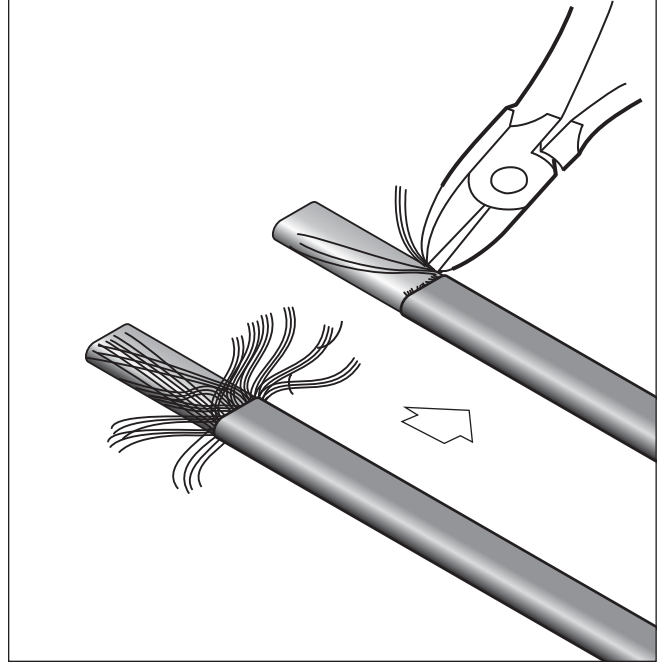

3

- Firmly push end seal onto the cable (at least 1½ inch). Some gel may ooze out.
- Do not twist or try to remove the end seal during or after insertion.
- Do not reuse an end seal.

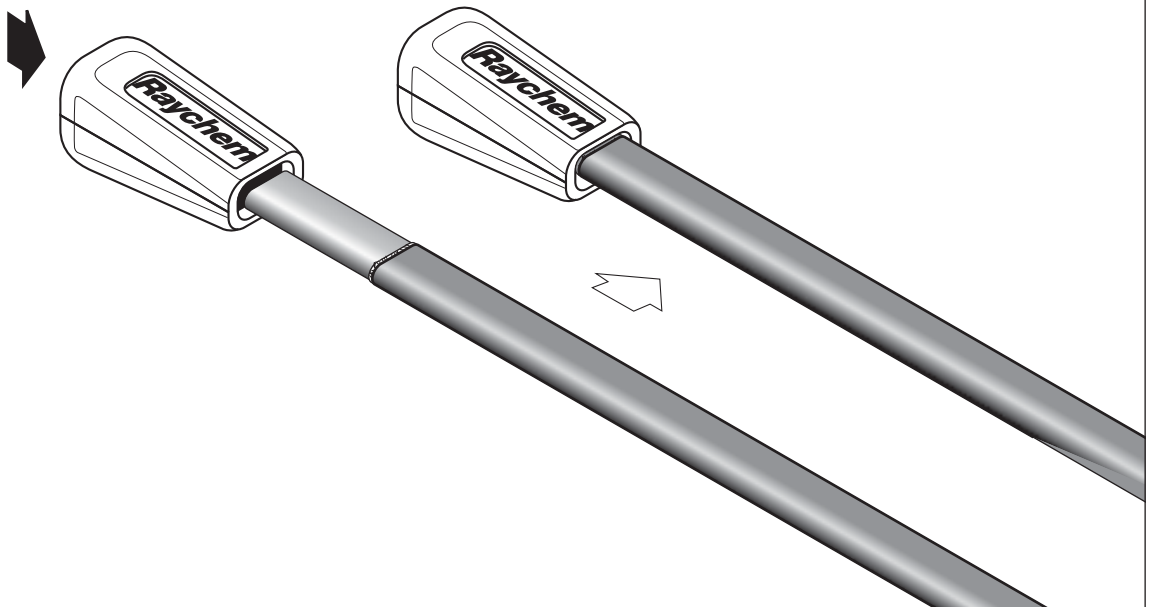

End Seal Installation Instructions for H311, H611 and H621 Heating Cables

Note: The end seal is designed to be installed only once. It cannot be removed from the heating cable once it is installed. Do not install it until instructed to do so in Step 3

1

- Cleanly cut off the end of the cable.

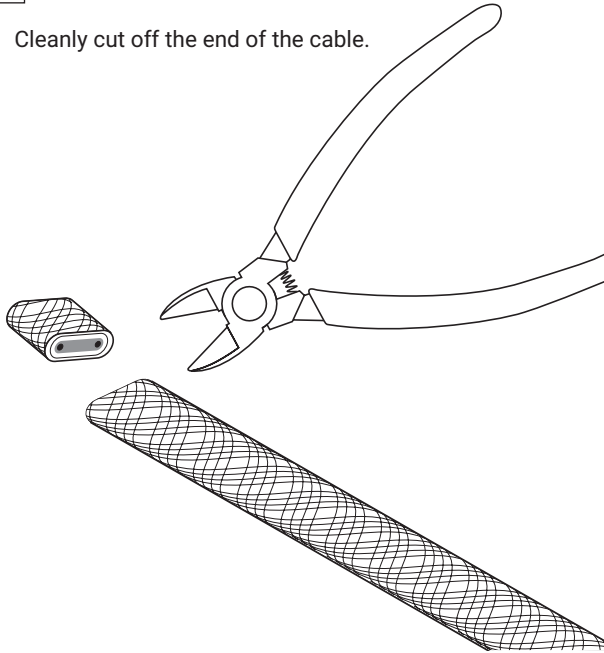

2

- Push the braid back 2 inches from the cable end.

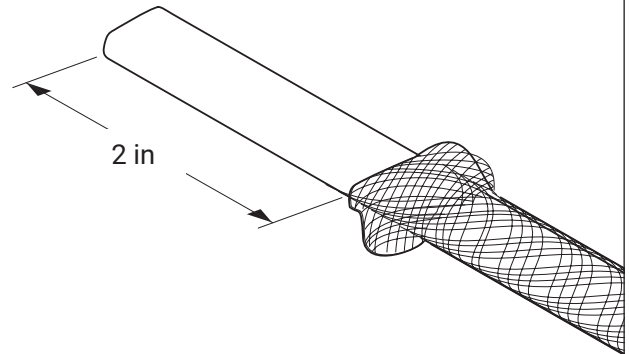

3

- Firmly push end seal onto the cable (at least 1½ inch). Some gel may ooze out.
- Do not twist or try to remove the end seal during or after insertion.
- Do not reuse an end seal.

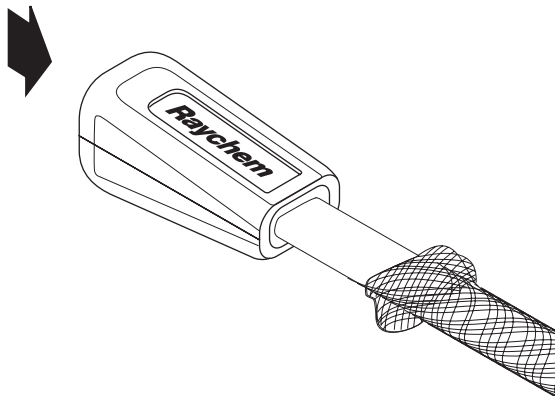

4

- Slide the braid up against the end seal and secure with the 6-inch length of tape provided.

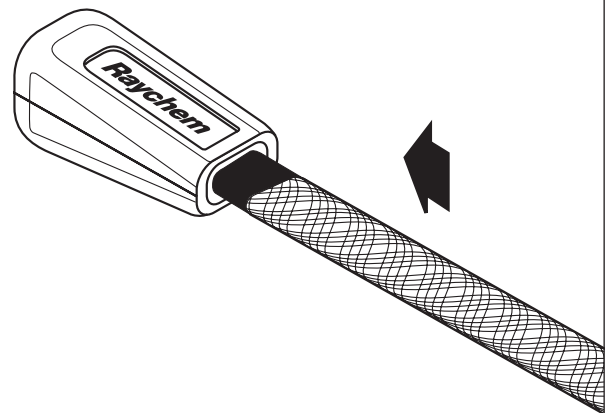

North America

Tel +1.800.545.6258
Fax +1.800.527.5703
thermal.info@nVent.com

Europe, Middle East, Africa

Tel +32.16.213.511
Fax +32.16.213.604
thermal.info@nVent.com

Asia Pacific

Tel +86.21.2412.1688
Fax +86.21.5426.3167
cn.thermal.info@nVent.com

Latin America

Tel +1.713.868.4800
Fax +1.713.868.2333
thermal.info@nVent.com



nVent.com/RAYCHEM