

KITS COMMON TO INDOOR COILS

©2024
Dallas, Texas, USA

508467-01
07/2024

REFRIGERANT DETECTION SENSOR KIT

Installation Instructions for Refrigerant Detection Sensor Kit – Indoor Coils

RETAIN THESE INSTRUCTIONS FOR FUTURE REFERENCE

WARNING

Improper installation, adjustment, alteration, service or maintenance can cause property damage, personal injury or loss of life. Installation and service must be performed by a licensed professional HVAC installer or equivalent or service agency.

CAUTION

As with any mechanical equipment, contact with sharp sheet metal edges can result in personal injury. Take care while handling this equipment and wear gloves and protective clothing.

WARNING



Electric Shock Hazard. Can cause injury or death. Unit must be properly grounded in accordance with national and local codes.

Line voltage is present at all components when unit is not in operation on units with single-pole contactors. Disconnect all remote electric power supplies before opening access panel. Unit may have multiple power supplies.

CAUTION

Refrigerant Detection System installed. Unit must be powered except for service.

WARNING

RISK OF ELECTRIC SHOCK. CAN CAUSE INJURY OR DEATH: System contains two independent protective earthing (grounding) terminals which both shall be properly connected and secured.

WARNING

If this appliance is conditioning a space with an area smaller than T_{Amin}, then that space must be without continuously operating open flames (e.g. an operating gas appliance) or other potential ignition sources (e.g. an operating electric heater or similar hot surface). A flame-producing device may be installed in the same space if the device is provided with an effective flame arrest system.

T_{Amin} Table

Charge (lb)	10.0	15.0	20.0	25.0	30.0
Charge (kg)	4.5	6.8	9.1	11.3	13.6
Minimum Conditioned Area (ft ²)	149.9	224.9	299.9	374.8	449.8
Minimum Conditioned Area (m ²)	13.9	20.9	27.9	34.8	41.8

CAUTION

Equipment shall be labeled stating that it has been decommissioned and emptied of refrigerant. The label shall be dated and signed. For appliances containing flammable refrigerants, ensure that there are labels on the equipment stating the equipment contains flammable refrigerant.

WARNING

Auxiliary devices which may be a potential ignition source shall not be installed in the duct work. Examples of such potential ignition sources are hot surfaces with a temperature exceeding 700°C and electric switching devices.

WARNING

For appliances using A2L refrigerants connected via an air duct system to one or more rooms, only auxiliary devices approved by the appliance manufacturer or declared suitable with the refrigerant shall be installed in connecting ductwork.

WARNING

For duct connected appliances, false ceilings or drop ceilings may be used as a return air plenum if a REFRIGERANT DETECTION SYSTEM is provided in the appliance and any external connections are also provided with a sensor immediately below the return air plenum duct joint.

CAUTION

Any service personnel installing, decommissioning, or performing maintenance on the unit must be properly trained with A2L refrigerants

IMPORTANT

RDS system requires 3 VA additional loading on low voltage transformer.



NOTE – Multiply values in T_{Amin} table by the Altitude Adjustment Factors to correct T_{Amin} based on installed altitude.

Altitude Adjustment Factor

Altitude (m)	0	200	400	600	800	1000	1200	1400	1600
Altitude (ft)	0	660	1310	1970	2620	3280	3940	4590	5250
Adj. Factor	1	1	1	1	1.02	1.05	1.04	1.1	1.12
Altitude (m)	1600	1800	2000	2200	2400	2600	2800	3000	3200
Altitude (ft)	5250	5910	6560	7220	7870	8530	9190	9840	10500
Adj. Factor	1.12	1.15	1.18	1.21	1.25	1.28	1.32	1.36	1.4

⚠ WARNING

- Do not use means to accelerate the defrosting process or to clean, other than those recommended by the manufacturer.
- The appliance shall be stored in a room without continuously operating ignition sources (for example: open flames, an operating gas appliance, or an operating electric heater).
- Do not pierce or burn.
- Be aware that refrigerants may not contain an odor.

⚠ WARNING

Ducts connected to an appliance shall not contain a potential ignition source

NOTE – Partial units shall only be connected to an appliance suitable for the same refrigerant.

Shipping and Packing List

- 4 – Sensor mounting brackets
- 1 – Refrigerant detection sensor
- 8 – Screws
- 1 – Wire routing grommet
- 1 – Line set joint sleeve kit
 - Liquid line sleeve (1)
 - Suction line sleeve (1)
 - Band clamps (3)
 - Suction line insulation tape (1)
- Warning labels (6)
 - 107895-01
 - 108173-01
 - 107659-01
 - 107894-01
 - 107662-01
 - 107893-01

General

This kit outlines the procedures to install the sensor mounting bracket and the installation of the sensor to the bracket, including wiring procedures.

This sensor kit is required in R454B applications, and compatible with any R-410A coil or AHU as outlined in the product installation instructions. These instructions are meant to be a companion of the original product installation instructions when installing the product in R454B applications.

⚠ IMPORTANT

In addition to conventional charging procedures, the following requirements shall be followed.

- Ensure that contamination of different refrigerants does not occur when using charging equipment. Hoses or lines shall be as short as possible to minimize the amount of refrigerant contained in them.
- Cylinders shall be kept in an appropriate position according to the instructions.
- Ensure that the REFRIGERATING SYSTEM is earthed prior to charging the system with refrigerant.
- Label the system when charging is complete (if not already).
- Extreme care shall be taken not to overfill the REFRIGERATING SYSTEM.

Prior to recharging the system, it shall be pressure-tested with the appropriate purging gas. The system shall be tested on completion of charging but prior to commissioning. A follow up test shall be carried out prior to leaving the site.

- Work shall be undertaken under a controlled procedure so as to minimize the risk of a flammable gas or vapor being present while the work is being performed.
- The area shall be checked with an appropriate refrigerant detector prior to and during work, to ensure the technician is aware of potentially toxic or flammable atmospheres. Ensure that the detection equipment being used is suitable for use with all applicable refrigerants, i. e. non-sparking, adequately sealed or intrinsically safe.
- If any hot work is to be conducted on the refrigerating equipment or any associated parts, the appropriate fire extinguishing equipment shall be available to hand. Have a dry powder or CO₂ fire extinguisher adjacent to the charging area.
- No person carrying out work in relation to a refrigerating system which involves exposing any pipe work shall use any sources of ignition in such a manner that it may lead to the risk of fire or explosion. All possible ignition sources, including cigarette smoking, should be kept sufficiently far away from the site of installation, repairing, removing and disposal, during which refrigerant can possibly be released to the surrounding space. Prior to work taking place, the area around the equipment is to be surveyed to make sure that there are no flammable hazards or ignition risks. “No Smoking” signs shall be displayed.

- Ensure that the area is in the open or that it is adequately ventilated before breaking into the system or conducting any hot work. A degree of ventilation shall continue during the period that the work is carried out.
- Pipe-work including piping material, pipe routing, and installation shall include protection from physical damage in operation and service, and be in compliance with national and local codes and standards
- All field joints shall be accessible for inspection prior to being covered or enclosed
- Where electrical components are being changed, they shall be fit for the purpose and to the correct specification. At all times the manufacturer's maintenance and service guidelines shall be followed. If in doubt, consult the manufacturer's technical department for assistance. The following checks shall be applied to installations using FLAMMABLE REFRIGERANTS as applicable:
 1. The actual refrigerant charge is in accordance with the room size within which the refrigerant containing parts are installed.
 2. The ventilation machinery and outlets are operating adequately and are not obstructed.
 3. If an indirect refrigerating circuit is being used, the secondary circuit shall be checked for the presence of refrigerant.
 4. Markings on the equipment should be visible and legible. Markings and signs that are illegible shall be corrected.
 5. Refrigerating pipe or components are installed in a position where they are unlikely to be exposed to any substance which may corrode refrigerant containing components, unless the components are constructed of materials which are inherently resistant to being corroded or are suitably protected against being so corroded.
- For systems containing refrigerant, all repair and maintenance to electrical components shall include initial safety checks and component inspection procedures such as that capacitors are discharged in a safe manner to avoid possibility of sparking, that no live electrical components and wiring are exposed while charging, recovering, or purging the system, and that there is continuity of earth bonding. If a fault exists that could compromise safety, then no electrical supply shall be connected to the circuit until it is satisfactorily dealt with. If the fault cannot be corrected immediately but it is necessary to continue operation, an adequate temporary solution shall be used that is reported to the owner of the equipment, so all parties are advised.
- Under no circumstances shall potential sources of ignition be used in the searching for or detection of refrigerant. A halide torch (or any other detector using a naked flame) shall not be used. The following detection methods are deemed acceptable for all refrigerant systems. Electronic detectors may be used to detect refrigerant, but, in the case of flammable refrigerants, the sensitivity may not be adequate, or may need re-calibration. (Detection equipment shall be calibrated in a refrigerant-free area.) Ensure that the detector is not a potential source of ignition and is suitable for the refrigerant used. Refrigerant detection equipment shall be set at a percentage of the LFL of the refrigerant and shall be calibrated to the refrigerant employed, and that 12.5 % refrigerant is confirmed. Detection fluids are also suitable for use with most refrigerants but the use of detergents containing chlorine shall be avoided as the chlorine may react with the refrigerant and corrode the copper pipe-work. In the event refrigerant is detected by sensor, all naked flames shall be removed/extinguished. If refrigerant is found which requires brazing, all of the refrigerant shall be recovered from the system, or isolated (by means of shut off valves) in a part of the system remote from where refrigerant was detected.
- When breaking into the refrigerant circuit to make repairs – or for any other purpose – conventional procedures shall be used. However, for flammable refrigerants it is important that best practice be followed and, since flammability is a consideration, procedures such as safely remove refrigerant following local and national regulations, purging the circuit with inert gas, evacuating (optional for A2L), purging with inert gas (optional for A2L), or opening the circuit by cutting or brazing be adhered to. The refrigerant charge shall be recovered into the correct recovery cylinders if venting is not allowed by local and national codes. For appliances containing flammable refrigerants, the system shall be purged with oxygen-free nitrogen to render the appliance safe for flammable refrigerants. This process might need to be repeated several times. Compressed air or oxygen shall not be used for purging refrigerant systems. For appliances containing flammable refrigerants, refrigerants purging shall be achieved by breaking the vacuum in the system with oxygen-free nitrogen and continuing to fill until the working pressure is achieved, then venting to atmosphere, and finally pulling down to a vacuum (optional for A2L). This process shall be repeated until no refrigerant is within the system (optional for A2L). When the final oxygen-free nitrogen charge is used, the system shall be vented down to atmospheric pressure to be able to perform the required work. Ensure that the outlet for the vacuum pump is not close to any potential ignition sources and working area is well ventilated.

NOTE –*Sealed electrical components shall be replaced, not repaired.*

NOTE – *Intrinsically safe components must be replaced, not repaired.*

NOTE – *All maintenance staff and others working in the local area shall be instructed on the nature of work being carried out with work in confined spaces being avoided.*

Bracket / Sensor Installation

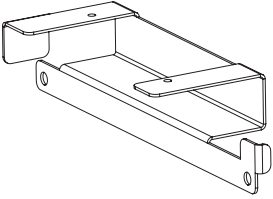
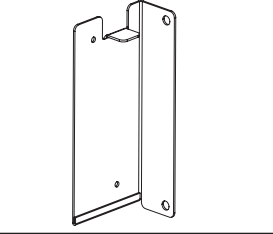
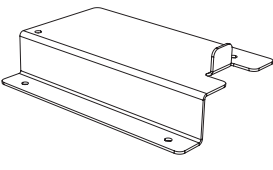
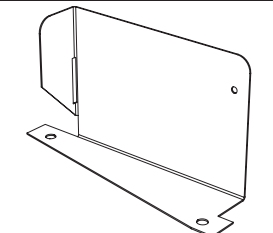
Bracket Identification	
Part Number	Bracket
626355-01	
626318-01	
626313-01	
067684800	

Refer to the installation instructions for the specific unit being updated.

UPFLOW 60D

- 1 - Select bracket 626355-01 from the kit. The bracket will look like figure 1.

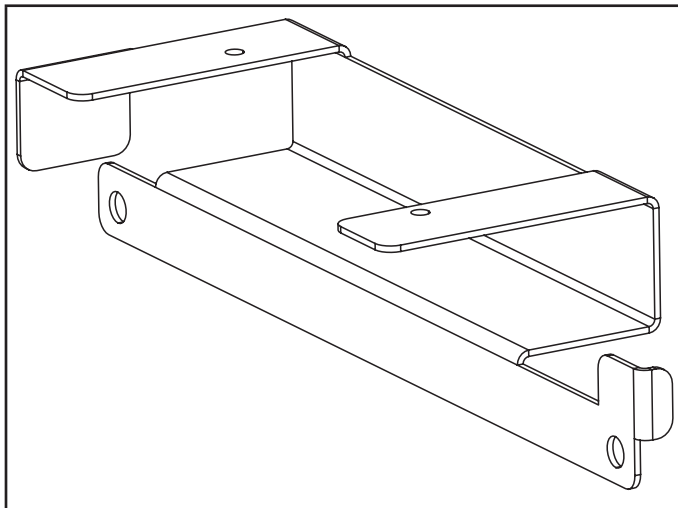

FIGURE 1

- 2 - Locate the bottom attachment hole in the coil end plate (figure 2).

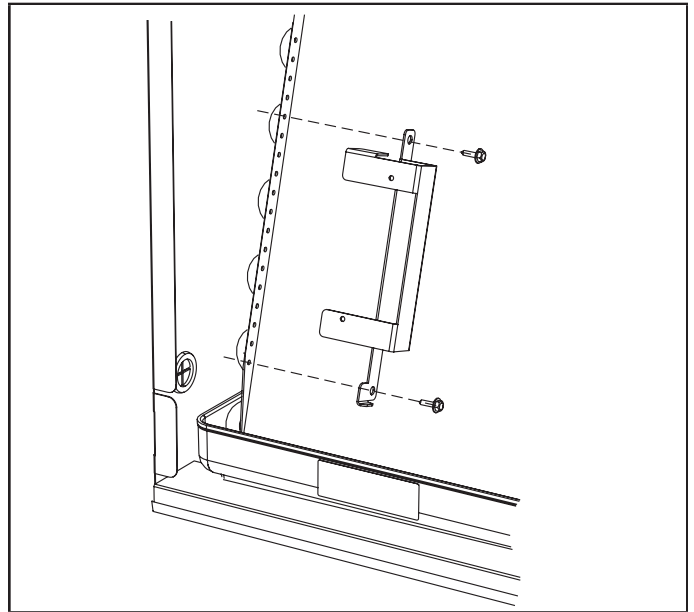

FIGURE 2

- 3 - Working from the inside of the coil, attach the bracket bottom clearance hole to the bottom attachment hole in the coil end plate using provided screws (figure 3).

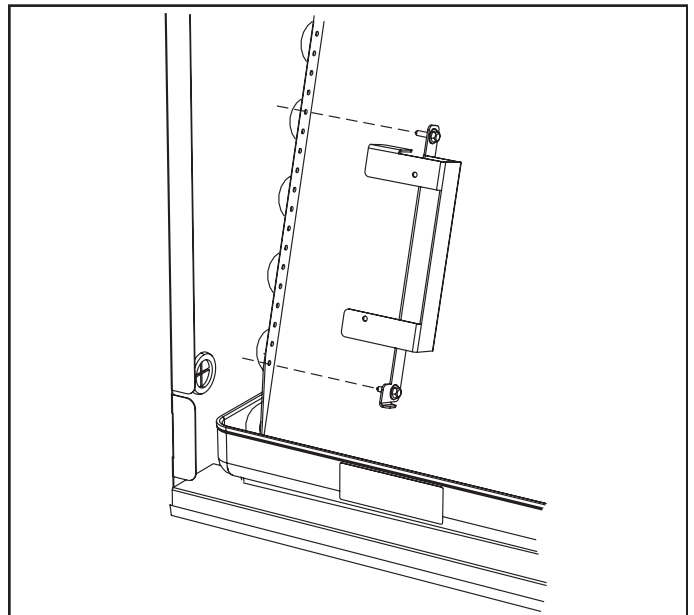

FIGURE 3

- 4 - Position sensor on bracket with sensor wire tucked behind the lower bracket attachment tab. Make sure the sensor mounting tabs are in front of the bracket (figure 4).

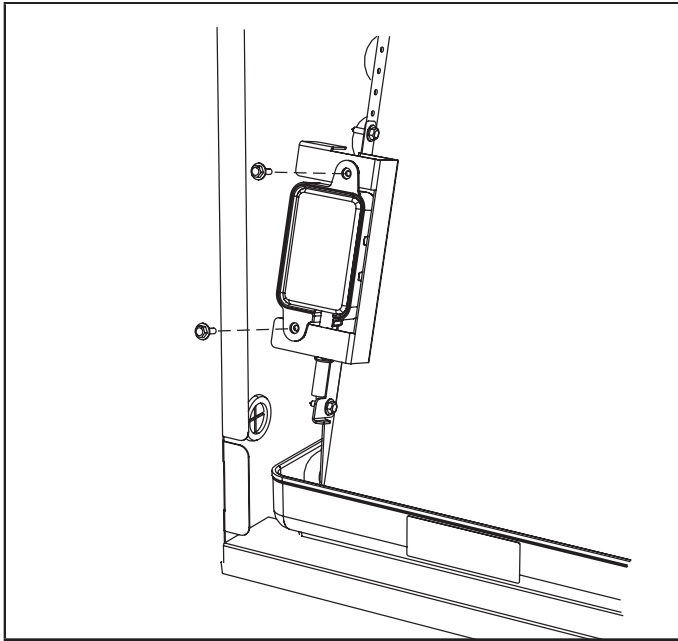

FIGURE 4

5 - Install sensor on bracket using provided screws (figure 5).

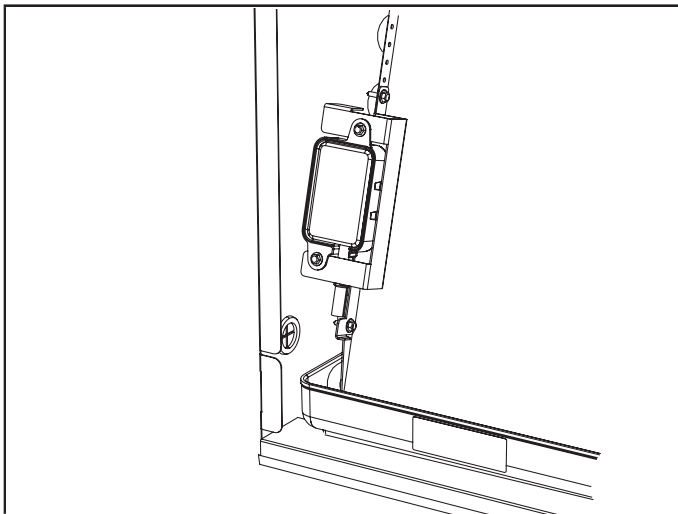

FIGURE 5

6 - Install grommet in cabinet opening (figures 6 and 7).

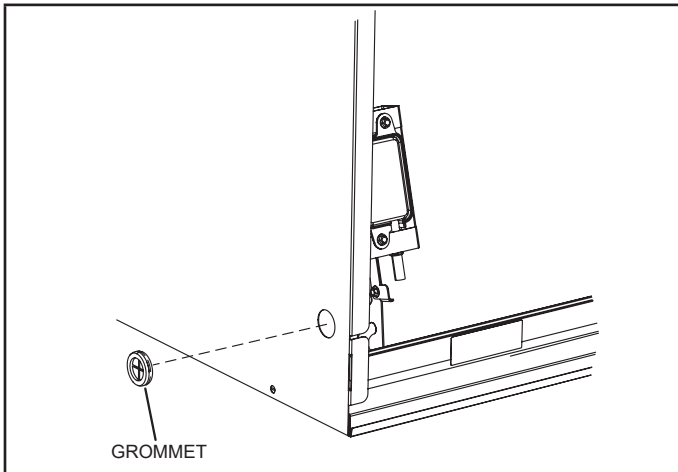

FIGURE 6

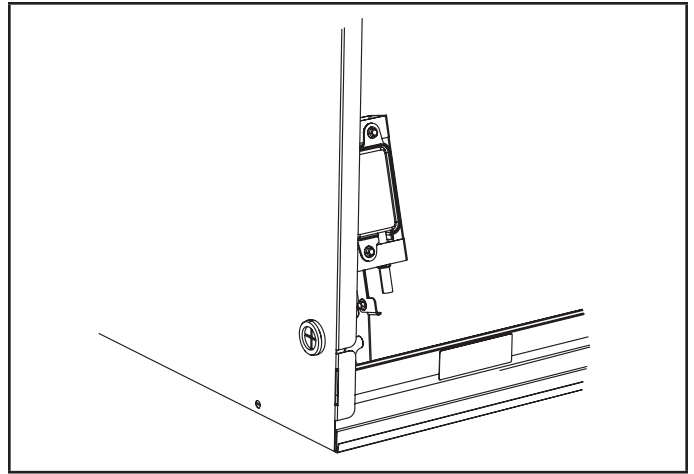

FIGURE 7

7 - Route sensor wire through the grommet, ensuring there is a drip loop in the wire.

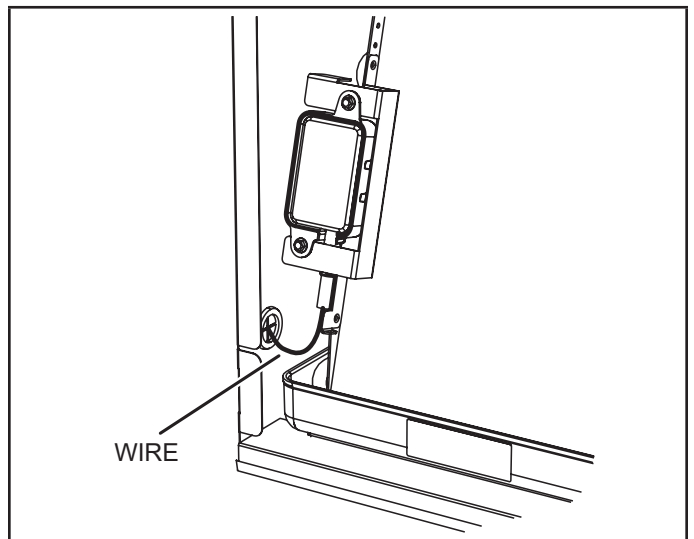

FIGURE 8

UPFLOW

1 - Select bracket 626318-01 from the kit. The bracket will look like figure 9.

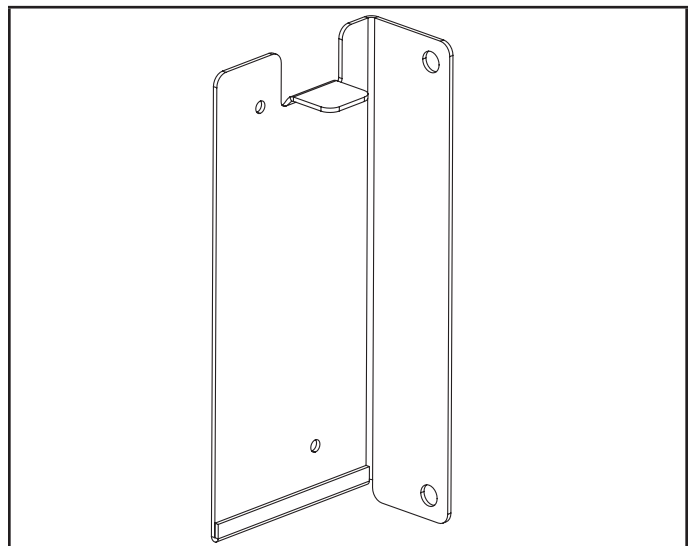

FIGURE 9

2 - Attach sensor to bracket using provided screws as shown in figures 10 and 11.

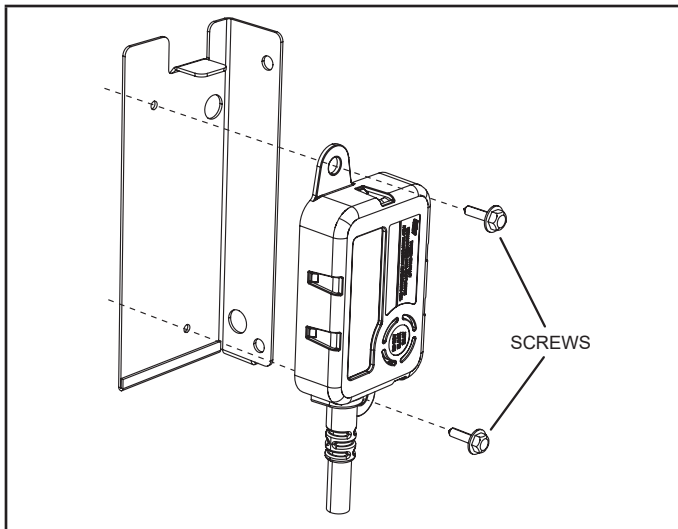

FIGURE 10

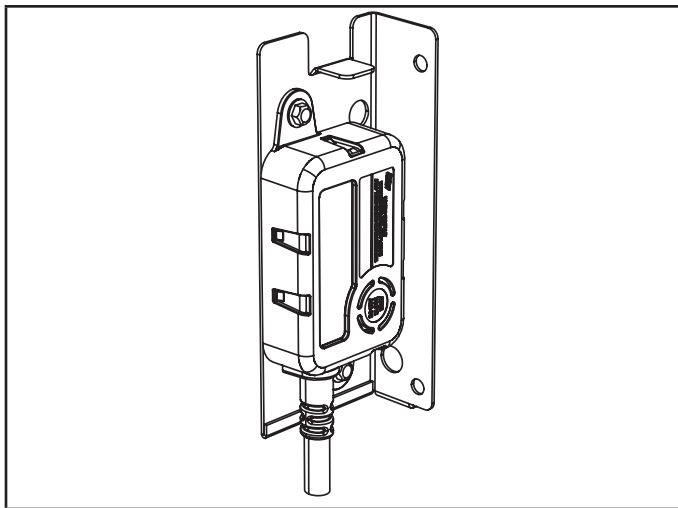

FIGURE 11

3 - Locate the bottom attachment hole in the coil end plate (figure 12).

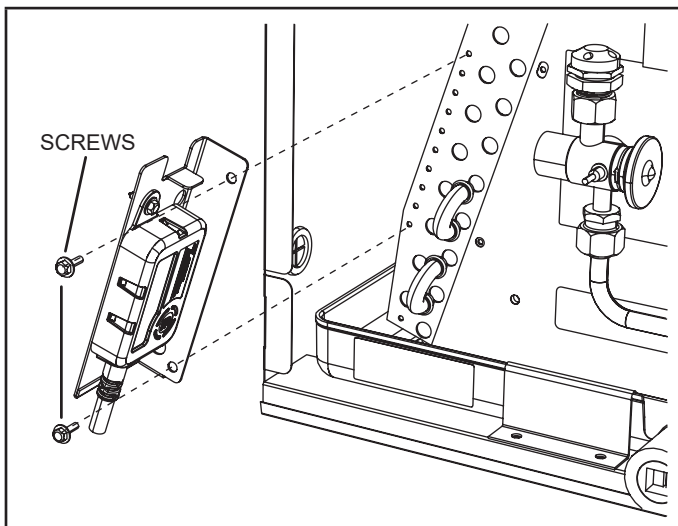

FIGURE 12

4 - Working from the front of the coil, attach the bottom clearance hole to the bottom attachment hole in the coil end plate (figure 13).

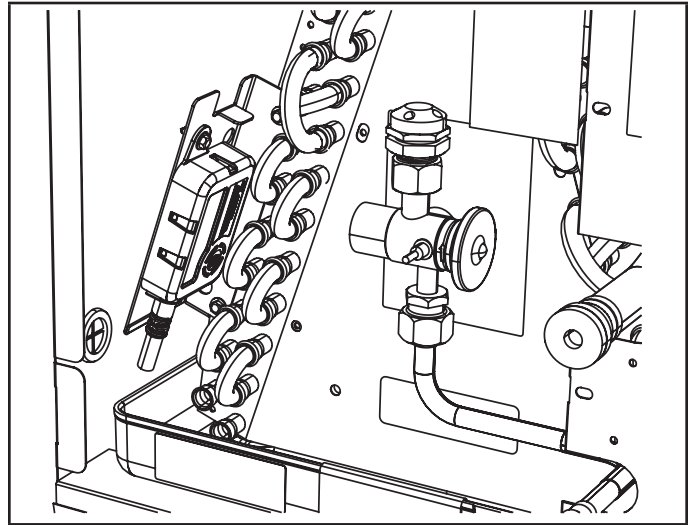

FIGURE 13

5 - Install grommet in cabinet opening (figures 14 and 15).

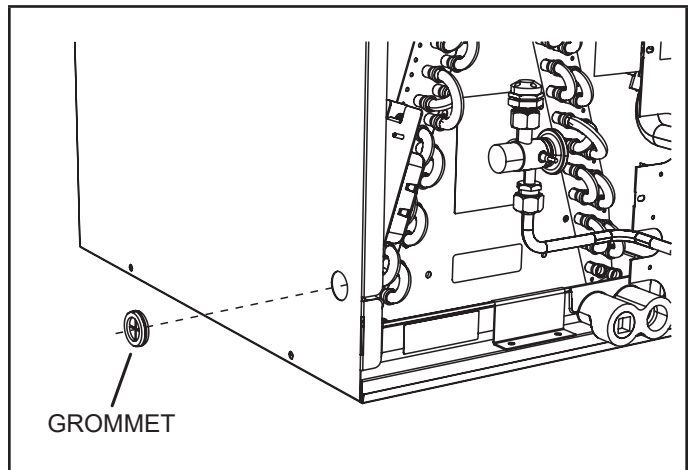

FIGURE 14

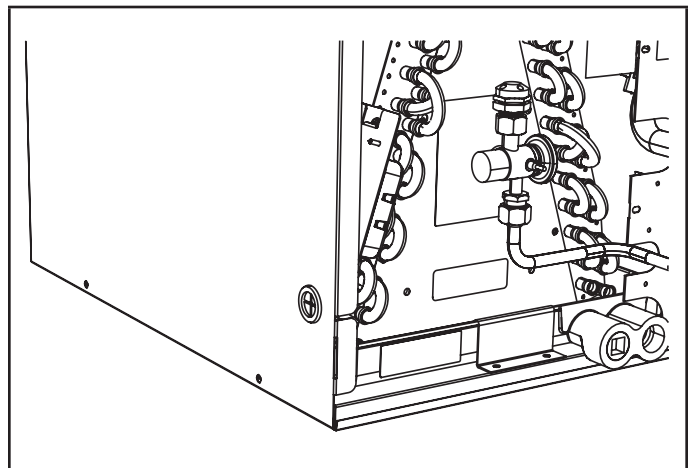

FIGURE 15

6 - Route sensor wire through the grommet, ensuring there is a drip loop in the wire (figure 16).

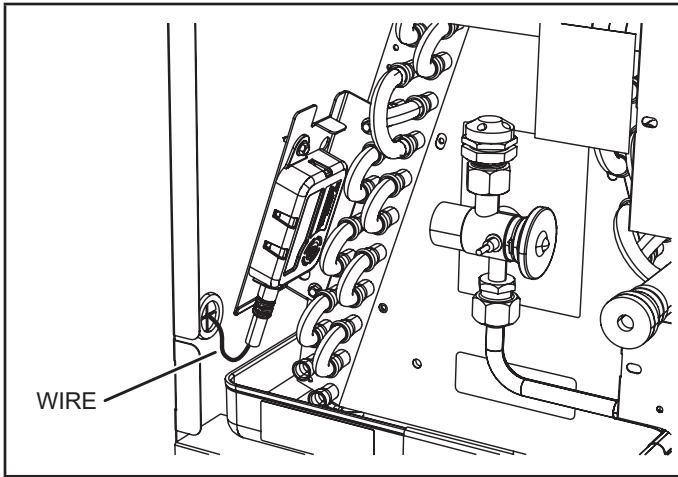

FIGURE 16

HORIZONTAL

1 - Select bracket 626313-01 from the kit. Bracket will look like figure 17.

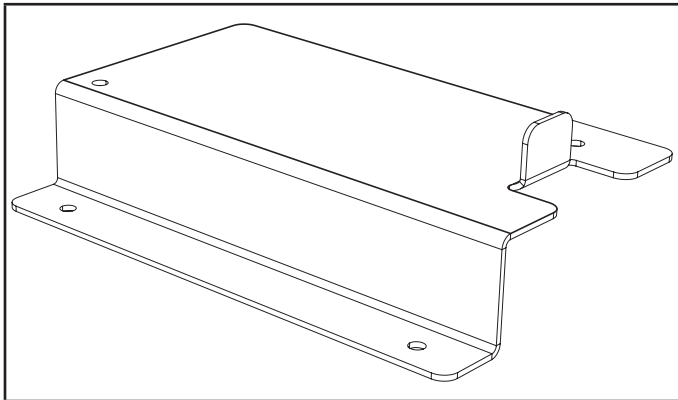

FIGURE 17

2 - Install sensor on the bracket (figures 18 and 19).

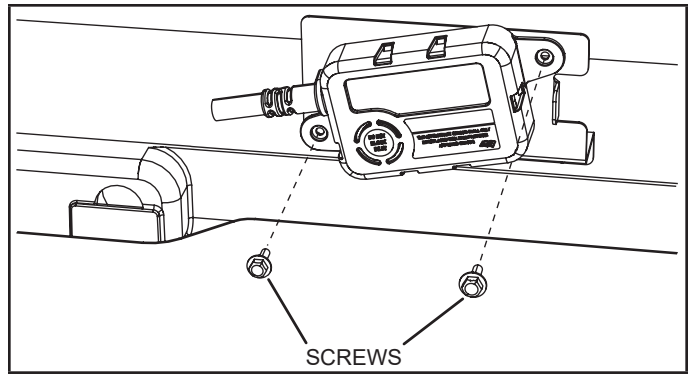

FIGURE 18

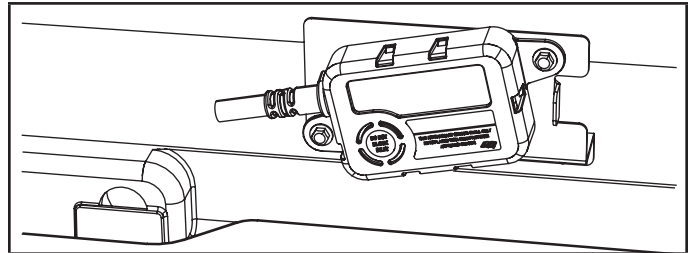

FIGURE 19

3 - Slide bracket flange under the piping panel insulation. Guiding slits in the insulation are shown in figure 20.

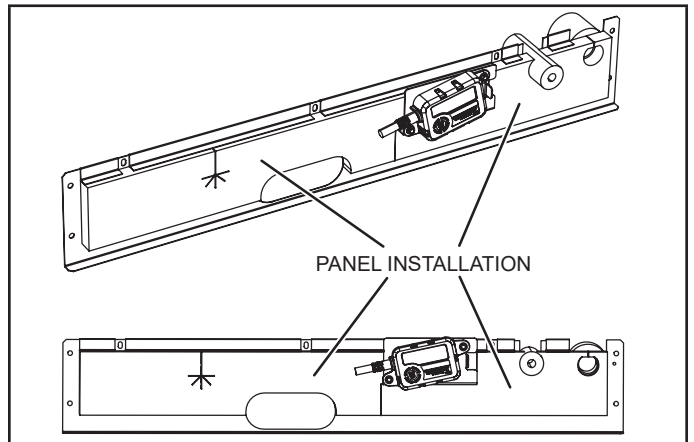

FIGURE 20

4 - Attach bracket to the piping panel (figure 21).

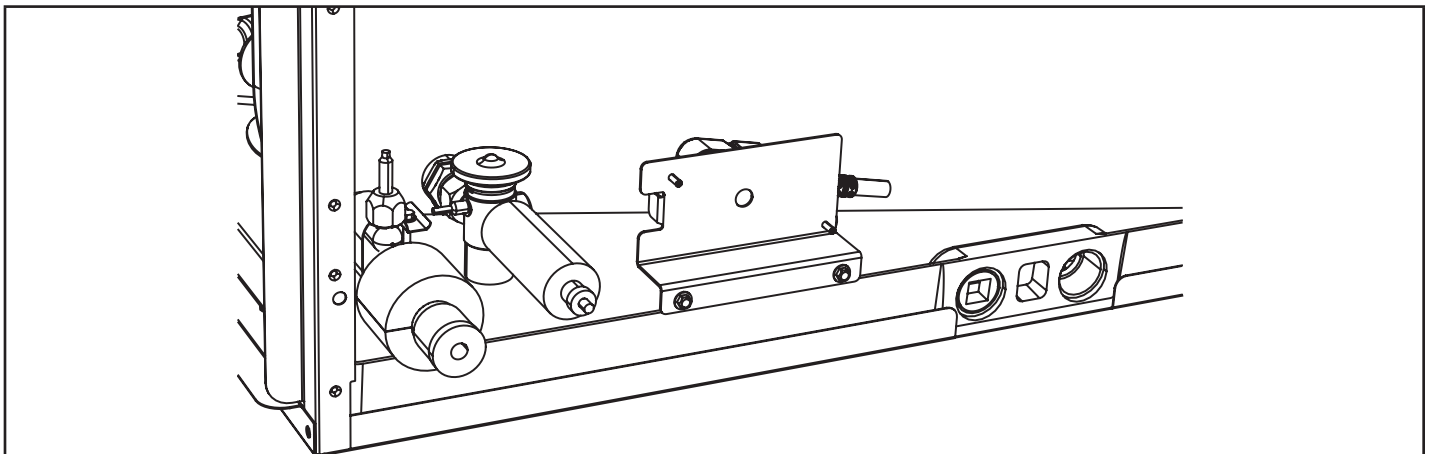

FIGURE 21

5 - Install grommet in cabinet opening (figures 22 and 23).

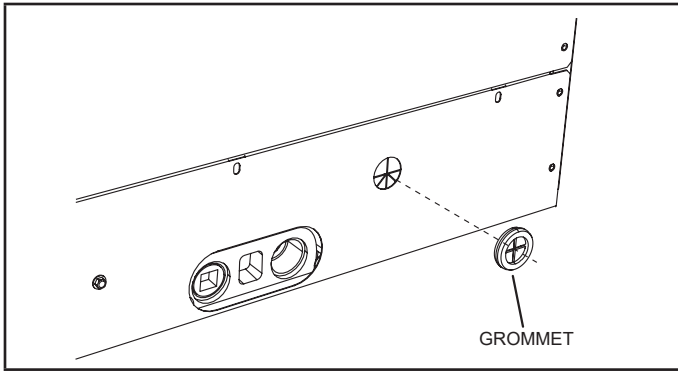

FIGURE 22

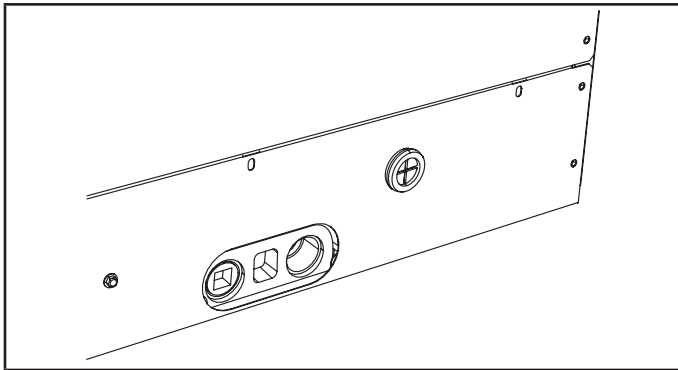

FIGURE 23

6 - Route wire through grommet out of the cabinet, ensuring there is a drip loop in the wire.

DOWNFLOW

1 - Select bracket 067684800 from the kit. Attach sensor to the bracket. Attach sensor bracket to the delta plate on evaporator coil (figures 24 and 25).

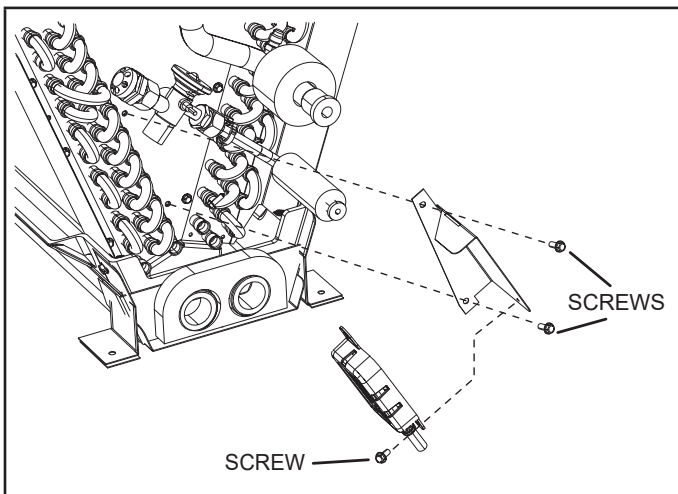

FIGURE 24

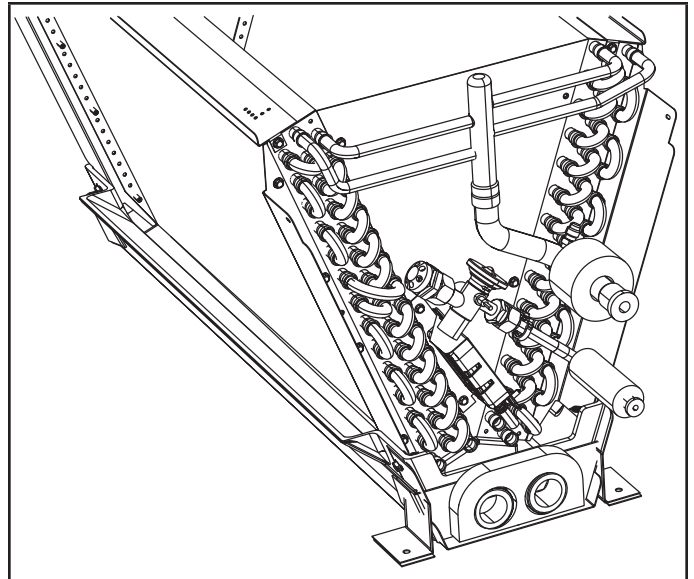

FIGURE 25

2 - Install grommet in the cabinet opening (figure 26).

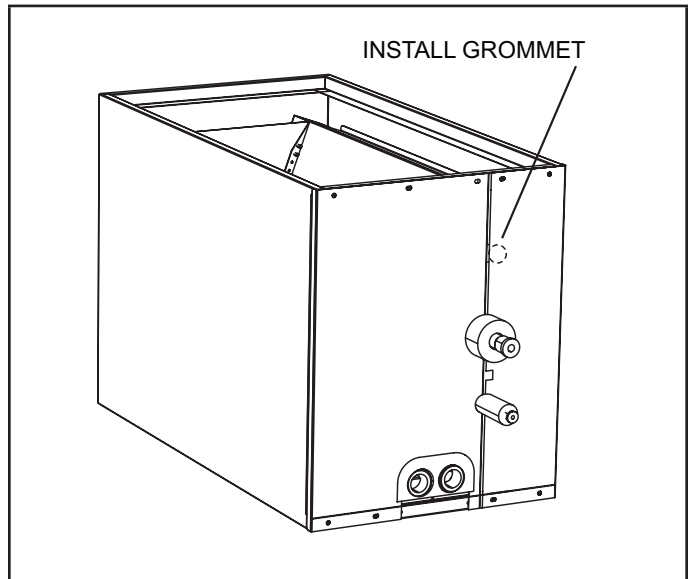

FIGURE 26

3 - Route sensor wire through grommet out of cabinet, ensuring there is a drip loop in the wire.

LABEL INSTALLATION

⚠ IMPORTANT
 Apply all warning labels to the plenum. Warning label application shown in figure 28 below.

OEM coils provide flexibility for installation with R-410A and R454B refrigerants.

This is applicable only during initial coil installation and is not applicable to existing installations.

When a coil is configured for R454B refrigerant during installation, the nameplate is required to be marked and all warning labels must be applied to the coil front panel before the refrigerant detection system installation is completed.

Warning labels **MUST BE VISIBLE** to service or inspection personnel. All required warning labels are provided in this Refrigerant Detection System kit. The labels that must be installed are:

107895-01, 108173-01, 107659-01, 107894-01, 107662-01, 107893-01

Please refer to the examples shown below.

1 - Nameplate Marking

Prior to installing the front panel, mark the unit nameplate to permanently identify the refrigerant configuration.

Nameplate example shown in figure 27 below.

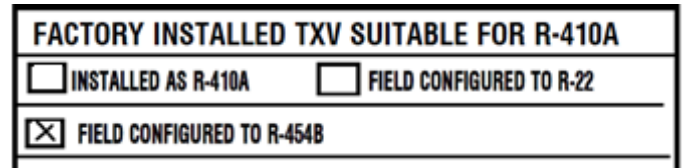

FIGURE 27

2 - Apply Warning Labels

Apply all warning labels to the front panel of the unit.

Warning label application shown in figure 28 below.

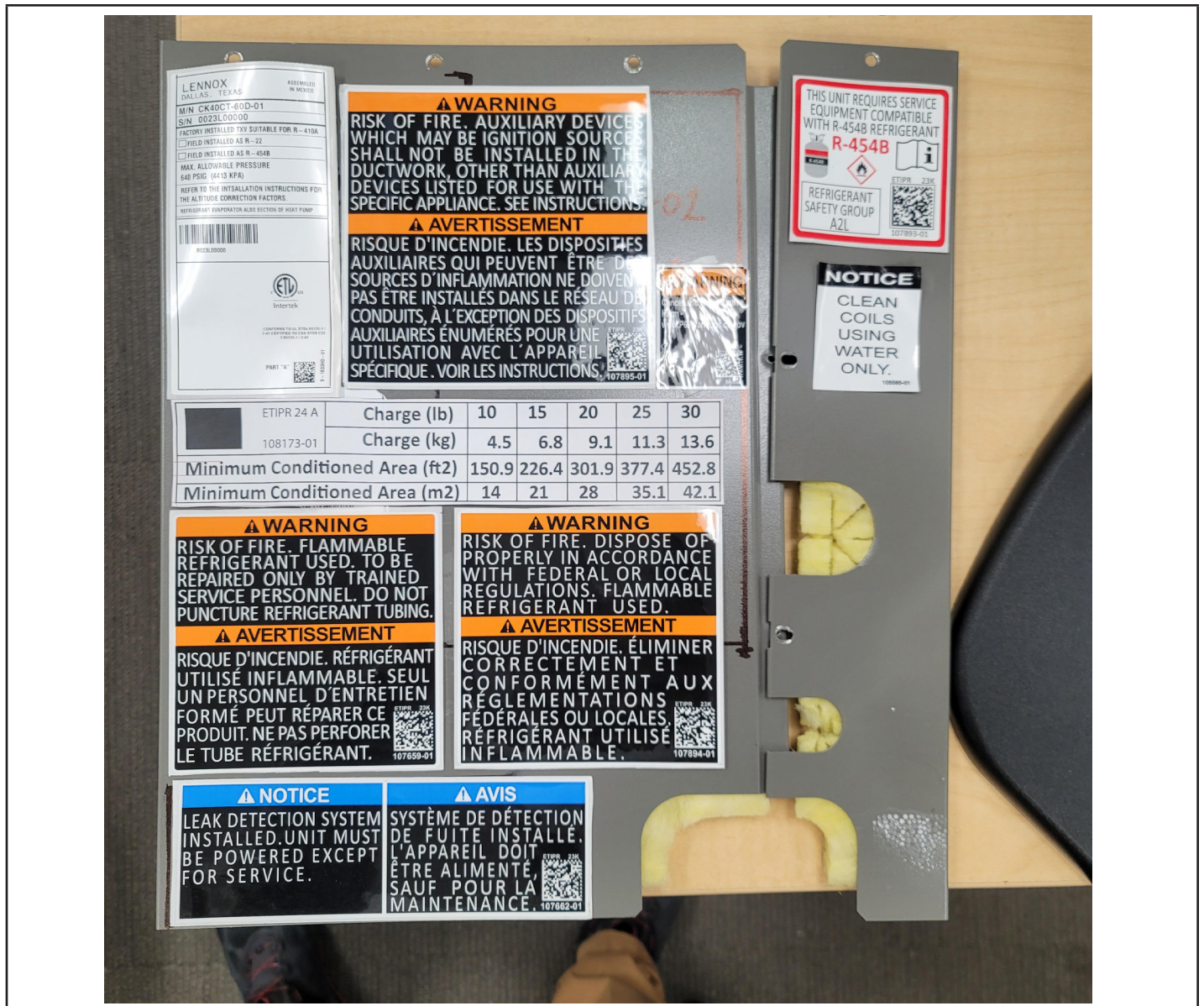

FIGURE 28

Line Set Joints

Evaporator primary line set joints in all applications shall have a line set joint sleeve.

Evaporator primary line sets should not have additional joints not covered by line set joint sleeve.

If additional joints are present, the system installation shall comply with one of the options below:

Option 1 - Furnace is installed as a direct vent appliance;

Option 2 - Furnace/Evaporator installation is in a space greater than the minimum conditioned area (A_{min});

Option 3 - Furnace/Evaporator installation is connected to a space greater than the minimum conditioned area (A_{min}) through an opening of at least 15 in² (4-inch diameter hole equivalent) located below the level of the furnace burners;

Option 4 - Have a second refrigerant detection sensor installed below the level of the burners (see Secondary Sensor Installation section).

Multiple Systems Installed in Same Space

For any A2L refrigerant system with additional joints not covered by line set joint sleeves, each system in the same space must have refrigerant detection sensor installed below the level of the burners (see Secondary Sensor Installation section). If all the systems in the same space are installed with direct vent application, then additional refrigerant detection sensor is not needed

Secondary Sensor Installation

If secondary refrigerant sensor is required, it shall be mounted as follows:

Upflow Applications: Mounted on an unused side furnace return air connection at least 9 inches above the floor and within 9 inches from front of furnace.

Horizontal Applications: Mounted on the lower section of the side return furnace air connection, within 9 inches of both the blower deck and front of furnace.

Downflow Applications: Mounted on one side of the evaporator coil 9 inches above the floor and within 9 inches from front of coil.

Connect the refrigerant sensor to the second sensor input on the RDS Control. Refer to the instructions provided with the sensor or the RDS controller to enable the second sensor.

Attaching Line Set Joint Sleeves

After system inspection and charging is complete, the line set joint sleeves must be properly positioned and attached to the coil cabinet. Use the following procedure for the suction and liquid lines.

Suction Line

- 1 - Using the insulation provided, wrap the section of the suction line next to the coil cabinet. Start at the coil piping panel and wrap the suction line with tape for approximately 7 inches. Make sure that insulation fits inside the sleeve.
- 2 - Carefully slide the sleeve over the insulation and insert into the "D" shaped opening in the coil cabinet. The cabinet sheet metal edges shall fit into the groove in the sleeve. Secure the sleeve to the cabinet with 2 sheet metal screws provided.
- 3 - Position the band clamp as shown in figure 29 and torque to 35 in-lbs to seal sleeve to line set.

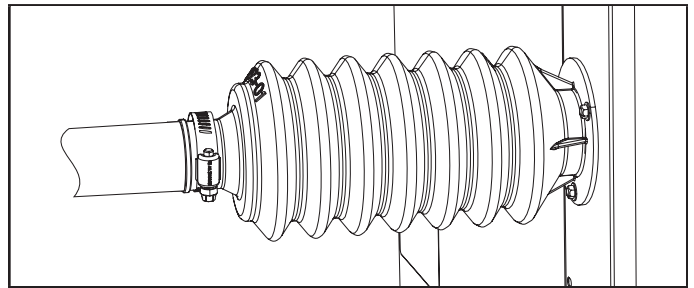

FIGURE 29. Band Clamp Installed on Sleeve

- 4 - Install a piece of field-supplied Armaflex over the band clamp and the end of the mitigation sleeve to prevent sweating (see figure 30).

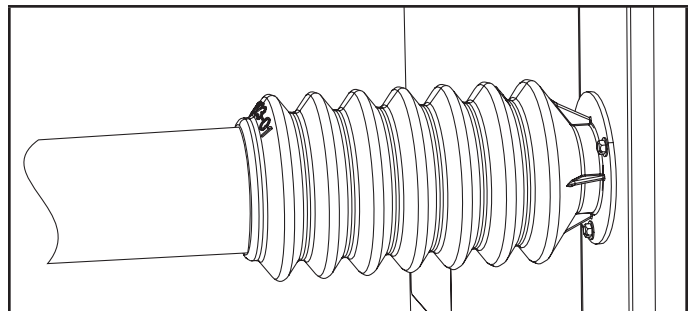

FIGURE 30. Install Armaflex Over End of Sleeve and Clamp

Liquid Line

- 1 - Slide sleeve over the field joint and insert into the "D" shaped opening in the cabinet. The cabinet sheet metal edges shall fit into the groove in the sleeve. Secure the sleeve to the cabinet with 2 sheet metal screws provided.
- 2 - Position the band clamp as shown in figure 29 and torque to 35 in-lbs to seal sleeve to line set.

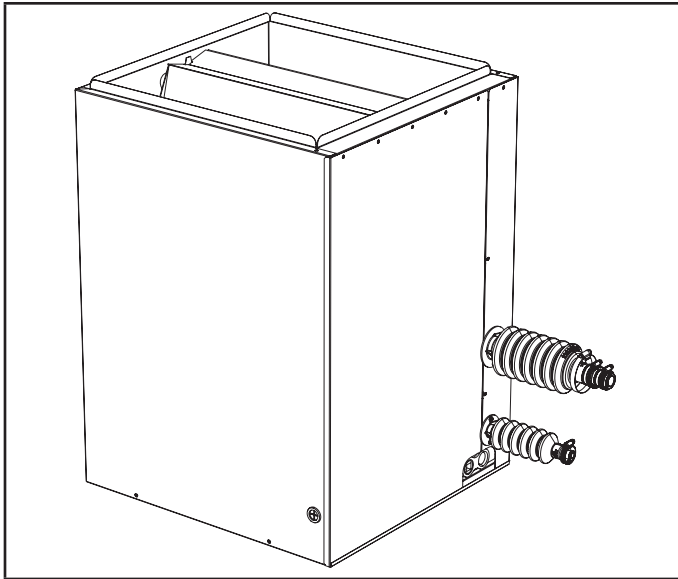

FIGURE 31. CK40CT with Line Set Joint Sleeves

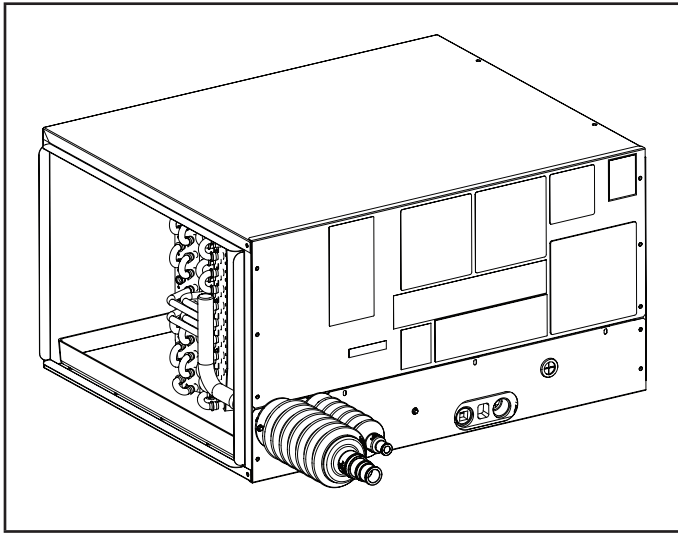

FIGURE 32. CK40HT with Line Set Joint Sleeves

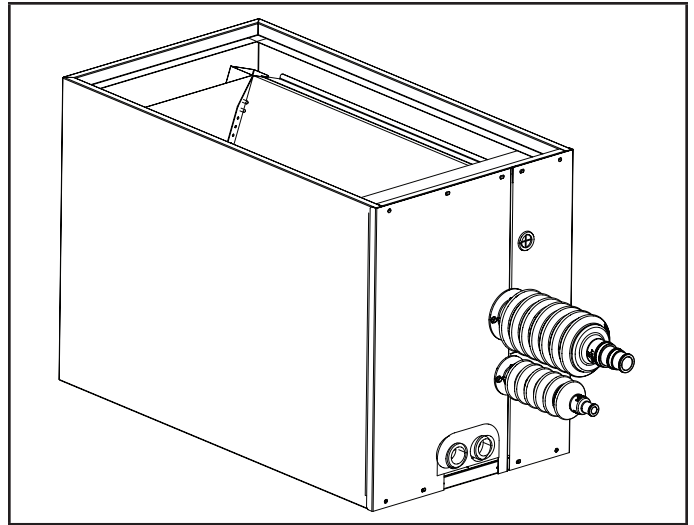

FIGURE 33. CK40DT with Line Set Joint Sleeves

Decommissioning

Before carrying out this procedure, it is essential that the technician is completely familiar with the equipment and all its detail. It is recommended good practice that all refrigerants are recovered safely.

Prior to the task being carried out, an oil and refrigerant sample shall be taken in case analysis is required prior to re-use of recovered refrigerant. It is essential that electrical power is available before starting decommissioning.

- a) Become familiar with the equipment and its operation.
- b) Isolate system electrically.
- c) Before attempting the procedure, ensure that:
 - mechanical handling equipment is available, if required, for handling refrigerant cylinders;
 - all personal protective equipment is available and being used correctly;

- the recovery process is supervised at all times by a competent person;
 - recovery equipment and cylinders conform to the appropriate standards.
- d) Pump down refrigerant system, if possible.
 - e) If a vacuum is not possible, make a manifold so that refrigerant can be removed from various parts of the system.
 - f) Make sure that cylinder is situated on the scales before recovery takes place.
 - g) Start the recovery machine and operate in accordance with instructions.
 - h) Do not overfill cylinders (no more than 80% volume liquid charge).
 - i) Do not exceed the maximum working pressure of the cylinder, even temporarily.
 - j) When the cylinders have been filled correctly and the process completed, make sure that the cylinders and the equipment are removed from site promptly and all isolation valves on the equipment are closed off.
 - k) Recovered refrigerant shall not be charged into another REFRIGERATING SYSTEM unless it has been cleaned and checked.

Sensor Maintenance

It is recommended to check the state of the sensor every 6 months, at the beginning of each cooling and heating season.

- Ensure that the sensor opening is clear and free of debris.
- Check that the sensor cable is in good condition.

- DO NOT use abrasive cleaning solutions to clean sensor opening.
- DO NOT use flammable compressed air solutions to clean the sensor opening.
- DO NOT vacuum sensor inlet opening, as this could cause damage to the sensor internal components.
- DO NOT use detergents to clean sensor.
- If sensor is clogged, it is recommended to replace sensor.
- When cleaning the evaporator coil, remove sensor from the coil. Follow recommended coil cleaning guidelines as described in installation instructions.



FIGURE 34. Example of Clear, Unobstructed Sensor Inlet