

7AH2AE

Upflow/Horizontal | Constant Torque Motor | TXV Furnished | R-454B | 60Hz

RESIDENTIAL
PRODUCT SPECIFICATIONS

1.5 to 5 Tons
Optional Electric Heat - 5 to 25 kW



MODEL NUMBER IDENTIFICATION

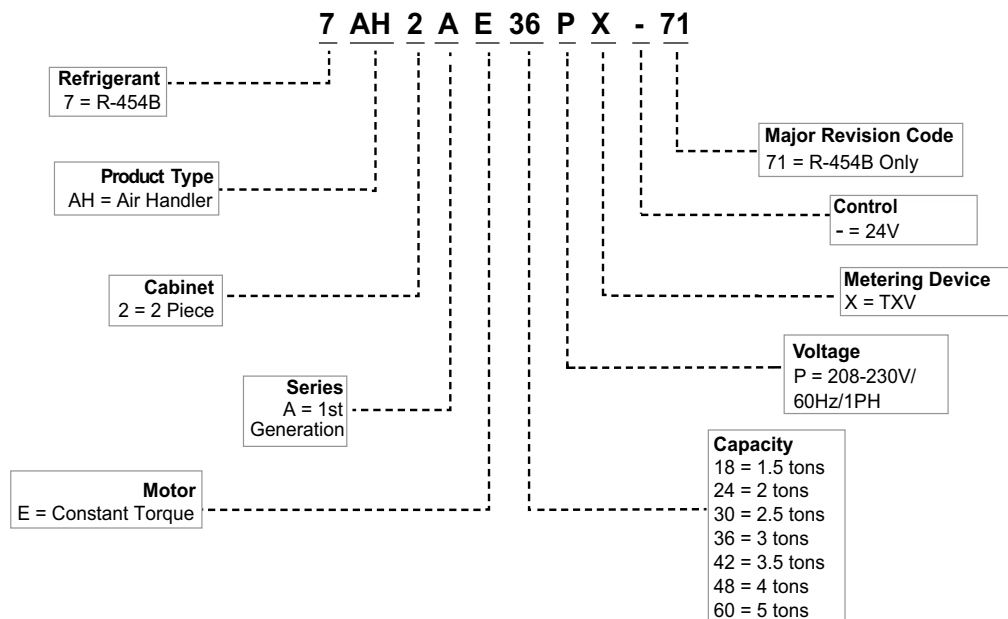

FEATURE HIGHLIGHTS

1. Omniguard® Coil
2. Mechanical or Brazed Line Set Connections
3. Check and Expansion Valve
4. Constant Torque Blower Motor
5. Heavy Gauge Steel Cabinet
6. Dual Position Anti-Microbial Drain Pans
7. Electric Heat (optional)
8. Built-in Filter Rack

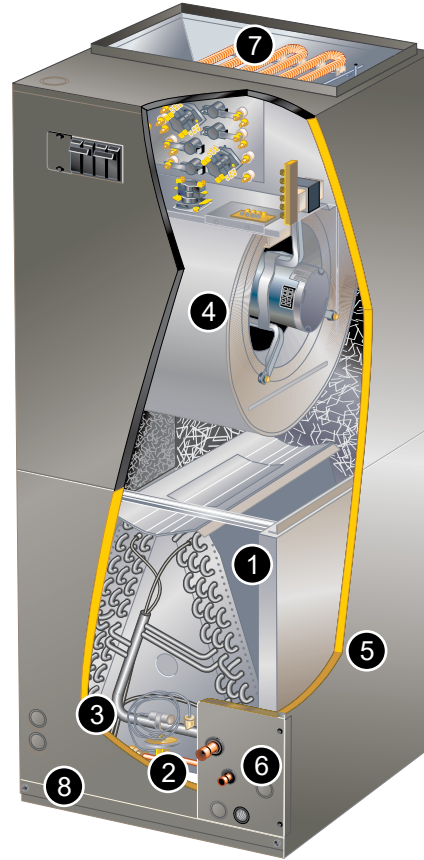

CONTENTS

Model Number Identification	1
Approvals And Warranty	3
Features.	3
Specifications	6
Electrical Data.	6
Optional Accessories - Order Separately	7
Installation Clearances With Electric Heat	7
Blower Data	8
Replacement Circuit Breakers	10
Electric Heat Data.	11
Dimensions	22
- Unit - Upflow Position	22
- Unit - Downflow Position.	23
- Unit - Horizontal Right-Hand Position	24
- Accessories	25

APPROVALS AND WARRANTY

APPROVALS

- Tested with matching air conditioners and heat pump units in accordance with AHRI Standard 210/240-2023
- AHRI Certified system match-ups and expanded ratings, visit www.alliedratings.com
- ETL Listed to US and Canadian safety standards and components within are bonded for grounding to meet safety standards for servicing required by NEC and CEC.
- Optional electric heaters are ETL listed and rated in accordance with US Department of Energy (DOE) test procedures and Federal Trade Commission (FTC) labeling regulations
- Blower performance data according to unit tests conducted in air test chamber
- Air handler units are approved for installation in manufactured housing and mobile homes.
- ISO 9001 Registered Manufacturing Quality System

WARRANTY

10-years limited warranty on all parts, extended warranty available.

Warranty provides for a total of 10-years of limited warranty.

Coverage (Standard 5-year limited parts warranty plus an additional 5-year limited extended parts warranty).

Warranty must be registered online within 60 days of installation to qualify for 10-year coverage.

Unregistered equipment defaults to 5-year coverage. See full warranty at www.alliedair.com for terms, conditions, and exclusions.

FEATURES

APPLICATIONS

- 1.5 to 5 ton nominal sizes
- Upflow or horizontal applications

NOTE - Downflow applications require optional conversion kit.

- Applicable to expansion valve systems in cooling applications and check and expansion valve systems in heat pump applications
- Wide-range check and expansion valve is factory installed
- Optional field installed electric heaters available in several sizes for additive heating capacity

REFRIGERANT SYSTEM

1 Omniguard® Coil

- Enhanced aluminum alloy tube/enhanced fin coil for superior corrosion resistance
- Aluminum tubing, hairpins, distributor and header tubes.
- Ripple-edged aluminum fins
- Twin coil construction assembled in a “A” configuration for large surface area
- Provides excellent heat transfer and low air resistance for maximum efficiency
- Precise circuiting for uniform refrigerant distribution
- Lanced fins provide maximum exposure of fin surface to air stream
- Axial grooved tubing provides superior heat transfer
- Coil thoroughly factory tested under high pressure to ensure leakproof construction

2 Mechanical or Brazed Line Set Connections

- Copper refrigerant sweat connections on both liquid and suction lines for easy brazing
- Lines extend outside of the cabinet for ease of connection
- See dimension drawings for locations

Braze-Free/Press Fitting Flexibility

- Units can accommodate braze-free or press fittings for installation versatility

3 R-454B Check and Expansion Valve

- For use with R-454B systems
- Wide range valve with Chatleff style fitting
- Factory installed on all models, internal to cabinet

REFRIGERANT DETECTION SYSTEM (RDS)

- Complies with UL 60335-2-40 approved standard
- Required for all systems using R-454B refrigerant
- Consists of a factory installed Refrigerant Detection System (RDS) sensor and a Refrigerant Detection System (RDS) Blower Control Board

Refrigerant Detection System (RDS) Air Handler Sensor

- Sensor ensures safe operation for systems equipped with R-454B refrigerant

- Indoor sensor will detect any R-454B refrigerant

NOTE - Sensor must be repositioned for horizontal-right, horizontal-left, and downflow applications.

FEATURES

Blower Control Board

- Connected to the RDS sensor
- Used as interface between indoor unit and thermostat to control system
- Ensures safe operation for systems equipped with R-454B refrigerant
- If R-454B refrigerant is detected, the refrigerant detection system will stop compressor and/or heating operation and operate the blower to reduce concentrations in the conditioned space
- Once safe levels are reached the HVAC system will resume normal operation
- Multi-color LED for system status and as an aid in troubleshooting
- Flashing LED codes for system status (Green/Blue) and diagnosing Sensor errors (Red)
- Alarm relay can trigger an external alarm if R-454B refrigerant is detected
- Zone relay opens all zone dampers (if part of a zoning system) if R-454B refrigerant is detected
- Power is disabled to thermostat to prevent demand if R-454B refrigerant is detected
- On system start-up blower will run for five minutes and any thermostat demands are disabled

NOTE - Refer to the Installation Instructions for additional information

BLOWER

4 **Constant Torque Blower Motor**

- Programmable high efficiency multi-speed blower motor. By maintaining constant torque output, blower motor can deliver more uniform (but not constant) airflow over the static pressure range
- Programmable multi-speed operation is achieved by the use of an ECM (Electronically Commutated Motor) motor
- Leadless blower motor features simple plug-in connections
- Choice of blower speeds is available. See Blower Data tables
- Blower speed change is easily accomplished by a simple wiring change

Blower Assembly

- Statically and dynamically balanced as an assembly before installation in the unit
- Blower motor is resiliently mounted to blower assembly
- Blower slides out of cabinet for servicing

5 **CABINET**

- Constructed of heavy-gauge galvanized steel
- Completely insulated with thick fiberglass insulation
- Pre-painted steel with mildly textured enamel finish with primer coat on unpainted side of all panels
- Shipped in one piece but may be disassembled into two separate sections for ease of installation in tight applications
- Thick rubber gasket between sections of the two-piece cabinet provides an air tight seal
- No exposed screw heads on sides for tight installations without damage to walls or woodwork
- Removable panels provide complete service access
- Electrical inlets provided in sides and top of cabinet

Low Leakage Cabinet

- All models have less than 2% air leakage and meet ANSI/ASHRAE Standard 193-2010 "Method of Test for Determining the Air Tightness of HVAC Equipment"

Upflow/Horizontal Capability (Optional Downflow)

- Shipped for upflow and horizontal right-hand discharge
- May be field converted to horizontal left-hand air discharge by repositioning horizontal drain pan
- Optional downflow kit required for field conversion

6 **Dual Position Anti-Microbial Drain Pans**

- Drain pans designed for upflow, downflow or horizontal applications
- Deep, corrosion resistant plastic drain pans have dual pipe drains
- Anti-Microbial additive resists growth of mold and mildew on drain pan which improves indoor air quality and reduces drain line blockage
- See dimension drawings

Optional Accessories

Downflow Combustible Flooring Floor Base (25 kW Electric Heat Applications Only)

- Base is required for models with 25 kW electric heat installed in downflow position on combustible floors

Downflow Conversion Kit

- Required for field conversion to downflow position
- Kit consists of drip shields and brackets for repositioning coil and drain pan

Horizontal Support Frame Kit

- Provides support of unit in horizontal applications
- Consists of (2) 1 x 1-1/2 x 32-5/8 in. and (2) 1 x 3 x 53-7/8 in. painted heavy gauge cold rolled steel support channels with assembly and suspending holes
- Bolts and nuts furnished for field assembly
- Suspending rods must be field provided

Side Return Unit Stand (Upflow Only)

- Raises unit 16 in. above floor for side return air duct connection
- Eliminates need for wooden platform construction

FEATURES

CABINET (Continued)

- All aluminum construction
- Two adjustable frames fit -018/024 thru -060 models

Wall Hanging Bracket Kit (Upflow Only)

- Allows unit to be hung on wall at any height
- Consists of heavy-gauge steel support brackets (one for air handler, one for wall mount)
- Screws furnished for fastening one bracket to unit
- Bolts for fastening one bracket to wall are field provided

High Performance Economizer (Commercial Applications Only)

- Designed for applications requiring outdoor air to be utilized in a commercial HVAC system. Allows the entry of fresh outdoor air for free cooling, reducing the requirement for mechanical cooling
- Heavy gauge galvanized steel cabinet lined with thick fiberglass insulation
- Mixed air sensor, outdoor air sensor and 24VAC transformer furnished
- Approved for California Title 24 building standards
- ASHRAE 90.1-2010 compliant
- See separate Product Specifications document for additional information and available control and sensor options

CONTROLS

Transformer

- 24 volt transformer with in-line fuse
- Factory installed in the unit control box

7 OPTIONAL ELECTRIC HEAT

- ETL listed
- Field install internal to unit cabinet
- Available in several voltages and kW sizes. See Electric Heat tables
- Helix wound nichrome heating elements exposed directly in air stream resulting in instant heat transfer, low element temperatures and long service life
- Each element equipped with accurately located limit control with fixed temperature off setting and automatic reset
- Supplemental thermal cutoff limit control, provides positive protection in case of excessive temperatures
- Thermal sequencer relay brings elements on and off line, in sequence and equal increments, with time delay between each
- Heating control relay(s) furnished as standard
- Control box and access cover constructed of heavy gauge galvanized steel
- Factory assembled with controls installed and wired
- Electric heat low voltage controls plug-in to air handler

Circuit Breaker (CB) Models

- All “CB” model heaters are equipped with circuit breakers for overload and short circuit protection
- Factory wired and mounted on electric heat unit
- Current sensitive and temperature actuated
- Manual reset
- Circuit breakers qualify as disconnect means at unit in many areas, eliminate the need for field provided disconnect
- Consult local electrical code in your area.

Optional Accessories

Electric Heat Circuit Breaker Cover Kit

- Flexible plastic cover protects circuit breaker
- Recommended in areas with high humidity or unconditioned areas to prevent nuisance tripping

Single-Point Power Source Control Box

- Control Box may be used with optional electric heat when single power supply is connected to multi-circuit electric heat
- Field installs external to the unit cabinet on either side or top
- Constructed of heavy gauge steel, baked enamel finish, pre-punched mounting holes, electrical inlet knockouts, and terminal strip
- Removable cover provides easy access
- Dimensions (H x W x D) - 7 x 7 x 4 in.

8 Filter

- Disposable 1 inch filter is furnished
- Filter rack furnished in cabinet for easy filter installation
- See Specifications tables for sizes

SPECIFICATIONS

Size		018	024	030	036
Nominal Tonnage		1.5	2	2.5	3
Refrigerant Type		R-454B	R-454B	R-454B	R-454B
Connections	Liquid line (OD) sweat - in.	3/8	3/8	3/8	3/8
	Suction line (OD) sweat - in.	3/4	3/4	3/4	3/4
	Condensate drain (FPT) - in.	(2) 3/4	(2) 3/4	(2) 3/4	(2) 3/4
Indoor Coil	Net face area - ft. ²	4.44	4.44	5.0	5.0
	Tube diameter - in.	3/8	3/8	3/8	3/8
	Rows	3	3	3	3
	Fins - in.	14	14	14	14
Blower	HP	1/2	1/2	1/2	1/2
	Wheel nominal diameter x width - in.	10 x 8	10 x 8	11 x 8	11 x 8
	Air volume range - cfm	262 - 959	365 - 1095	365 - 1278	606 - 1498
¹ Filters	Size - in.	20 x 20 x 1	20 x 20 x 1	20 x 20 x 1	20 x 20 x 1
Shipping Data - lbs.		137	137	150	150

ELECTRICAL DATA

Line voltage data (Volts-Phase-Hz)	208/230-1-60	208/230-1-60	208/230-1-60	208/230-1-60
	---	---	---	----
² Maximum overcurrent protection (MOCP) amps (unit)	15	15	15	15
Minimum circuit ampacity (MCA) - 208/230V (unit)	5.1	5.1	5.1	5.1
Blower Motor Full Load Amps - 208/230V	4.1	4.1	4.1	4.1

SPECIFICATIONS

Size		042	048	060
Nominal Tonnage		3.5	4	5
Refrigerant Type		R-454B	R-454B	R-454B
Connections	Liquid line (OD) sweat - in.	3/8	3/8	3/8
	Suction line (OD) sweat - in.	7/8	7/8	7/8
	Condensate drain (FPT) - in.	(2) 3/4	(2) 3/4	(2) 3/4
Indoor Coil	Net face area - ft. ²	7.22	7.22	8.33
	Tube diameter - in.	3/8	3/8	3/8
	Rows	3	3	3
	Fins - in.	14	14	14
Blower	HP	1	1	1
	Wheel nominal diameter x width - in.	12 x 9	12 x 9	12 x 9
	Air volume range - cfm	815 - 1723	867 - 1903	946 - 2268
¹ Filters	Size - in.	20 x 24 x 1	20 x 24 x 1	20 x 24 x 1
Shipping Data - lbs.		186	186	199

ELECTRICAL DATA

Line voltage data (Volts-Phase-Hz)	208/230-1-60	208/230-1-60	208/230-1-60
	---	---	----
² Maximum overcurrent protection (MOCP) amps (unit)	15	15	15
Minimum circuit ampacity (MCA) - 208/230V (unit)	10	10	10
Blower Motor Full Load Amps - 208/230V	7.6	7.6	7.6

¹ Disposable filter.

² HACR type circuit breaker or fuse.

³ Refer to National or Canadian Electrical Code manual to determine wire, fuse and disconnect size requirements. Use wires suitable for at least 167°F.

OPTIONAL ACCESSORIES - ORDER SEPARATELY

Description	Order Number
25kW Electric Heat Only	44K15
Downflow Conversion Kit	28B60
Electric Heat Circuit Breaker Cover Kit	82W01
Horizontal Support Frame Kit	56J18
Side Return Unit Stand (Upflow Only)	45K32
Single-Point Power Source Control Box (for Electric Heat)	21H39
Wall Hanging Bracket Kit (Upflow Only)	45K30
High Performance Economizer (Commercial Only)	10U53

INSTALLATION CLEARANCES WITH ELECTRIC HEAT

5 to 20kW Electric Heat		25kW Electric Heat	
Cabinet	0 inch (0 mm)	Cabinet	0 inch (0 mm)
To Plenum	0 inch (0 mm)	To Plenum	1 inch (0 mm)
To Outlet Duct	0 inch (0 mm)	To Outlet Duct within 3 feet (914 mm)	1 inch (0 mm)
Floor	0 inch (0 mm)	Floor	See Note #1
Service / Maintenance	See Note #2	Service / Maintenance	See Note #2

¹ Units installed on combustible floors in the downflow position with electric heat DO require a downflow combustible flooring base.

² Front service access - 24 inches (610 mm) minimum.

NOTE - If cabinet depth is more than 24 inches (610 mm), allow a minimum of the cabinet depth plus 2 inches (51 mm).

BLOWER DATA

7AH2AE-018 BLOWER PERFORMANCE

External Static Pressure in. w.g.	Air Volume and Motor Watts									
	Tap 1		Tap 2		Tap 3		Tap 4		Tap 5	
	cfm	Watts	cfm	Watts	cfm	Watts	cfm	Watts	cfm	Watts
0.10	589	55	713	80	805	101	805	101	963	155
0.20	520	61	666	88	760	109	760	109	928	163
0.30	452	67	601	96	710	118	710	118	889	173
0.40	407	73	548	101	647	126	647	126	851	181
0.50	344	81	502	107	598	132	598	132	803	190
0.60	293	84	456	114	561	138	561	138	748	199
0.70	---	---	418	122	522	143	522	143	714	207
0.80	---	---	362	128	479	150	479	150	676	213
0.90	---	---	315	132	435	162	435	162	640	220
1.00	---	---	---	---	389	167	389	167	602	228
1.10	---	---	---	---	341	173	341	173	576	234
1.20	---	---	---	---	---	---	---	---	540	243

NOTE - All air data measured external to unit with dry coil and 1 inch non-pleated air filter in place.
Electric heaters have no appreciable air resistance.

7AH2AE-024 BLOWER PERFORMANCE

External Static Pressure in. w.g.	Air Volume and Motor Watts									
	Tap 1		Tap 2		Tap 3		Tap 4		Tap 5	
	cfm	Watts	cfm	Watts	cfm	Watts	cfm	Watts	cfm	Watts
0.10	665	68	804	101	933	143	933	143	1056	197
0.20	613	74	762	106	889	151	889	151	1019	206
0.30	556	81	718	114	856	158	856	158	988	214
0.40	481	87	667	122	822	165	822	165	953	222
0.50	425	93	614	129	772	175	772	175	922	229
0.60	368	97	527	138	733	182	733	182	895	238
0.70	336	101	487	143	683	193	683	193	846	249
0.80	293	105	455	148	597	202	597	202	799	258
0.90	239	108	414	153	555	208	555	208	725	268
1.00	---	---	367	158	519	212	519	212	656	276
1.10	---	---	312	162	485	215	485	215	592	267
1.20	---	---	291	163	468	219	468	219	486	240

NOTE - All air data measured external to unit with dry coil and 1 inch non-pleated air filter in place.
Electric heaters have no appreciable air resistance.

7AH2AE-030 BLOWER PERFORMANCE

External Static Pressure in. w.g.	Air Volume and Motor Watts									
	Tap 1		Tap 2		Tap 3		Tap 4		Tap 5	
	cfm	Watts	cfm	Watts	cfm	Watts	cfm	Watts	cfm	Watts
0.10	775	77	1074	152	1158	182	1158	182	1256	215
0.20	727	84	1023	163	1115	193	1115	193	1215	226
0.30	669	91	990	170	1081	200	1081	200	1169	237
0.40	590	100	948	180	1040	211	1040	211	1135	246
0.50	522	106	913	186	1007	219	1007	219	1100	255
0.60	463	114	870	196	967	227	967	227	1065	263
0.70	417	121	812	206	930	236	930	236	1031	272
0.80	375	127	735	219	871	250	871	250	993	281
0.90	339	130	676	231	791	264	791	264	965	290

NOTE - All air data measured external to unit with dry coil and 1 inch non-pleated air filter in place.
Electric heaters have no appreciable air resistance.

BLOWER DATA

7AH2AE-036 BLOWER PERFORMANCE

External Static Pressure in. w.g.	Air Volume and Motor Watts									
	Tap 1		Tap 2		Tap 3		Tap 4		Tap 5	
	cfm	Watts	cfm	Watts	cfm	Watts	cfm	Watts	cfm	Watts
0.10	973	115	1239	210	1301	243	1301	243	1447	320
0.20	925	123	1194	221	1264	253	1264	253	1411	331
0.30	876	131	1156	230	1229	263	1229	263	1379	341
0.40	841	138	1118	240	1189	275	1189	275	1336	354
0.50	762	150	1082	248	1158	284	1158	284	1306	364
0.60	694	161	1049	257	1127	293	1127	293	1274	375
0.70	644	168	1001	270	1094	303	1094	303	1241	386
0.80	583	178	978	279	1032	321	1032	321	1215	394
0.90	552	184	868	299	958	339	958	339	1169	412
1.00	497	193	828	307	913	350	913	350	1112	430
1.10	455	201	783	318	877	357	877	357	1059	445
1.20	418	207	745	327	838	367	838	367	1011	458

NOTE - All air data measured external to unit with dry coil and 1 inch non-pleated air filter in place.
Electric heaters have no appreciable air resistance.

7AH2AE-042 BLOWER PERFORMANCE

External Static Pressure in. w.g.	Air Volume and Motor Watts									
	Tap 1		Tap 2		Tap 3		Tap 4		Tap 5	
	cfm	Watts	cfm	Watts	cfm	Watts	cfm	Watts	cfm	Watts
0.10	1185	150	1330	202	1534	279	1471	282	1697	405
0.20	1131	161	1278	214	1487	293	1437	292	1659	419
0.30	1077	171	1236	224	1447	304	1395	305	1620	434
0.40	1029	181	1191	235	1406	317	1353	315	1590	445
0.50	989	188	1152	244	1367	327	1310	331	1552	459
0.60	922	201	1107	255	1319	342	1277	341	1521	471
0.70	872	210	1061	265	1286	352	1240	352	1483	487
0.80	833	217	1013	276	1248	363	1200	365	1453	497
0.90	774	225	970	285	1199	377	1162	376	1415	511
1.00	742	233	937	293	1160	388	1085	393	1384	525
1.10	651	250	893	302	1121	398	1072	400	1302	544
1.20	606	259	816	315	1077	410	1038	410	1277	553

NOTE - All air data measured external to unit with dry coil and 1 inch non-pleated air filter in place.
Electric heaters have no appreciable air resistance.

7AH2AE-048 BLOWER PERFORMANCE

External Static Pressure in. w.g.	Air Volume and Motor Watts									
	Tap 1		Tap 2		Tap 3		Tap 4		Tap 5	
	cfm	Watts	cfm	Watts	cfm	Watts	cfm	Watts	cfm	Watts
0.10	1202	172	1569	355	1755	470	1753	472	1967	637
0.20	1147	192	1526	376	1713	486	1728	495	1942	647
0.30	1121	191	1498	372	1701	497	1675	497	1916	657
0.40	1066	201	1452	383	1675	529	1669	511	1879	681
0.50	1031	220	1430	411	1636	524	1639	536	1845	704
0.60	936	227	1400	404	1602	547	1594	548	1811	713
0.70	865	237	1358	421	1582	562	1584	541	1777	730
0.80	827	251	1328	441	1551	566	1545	569	1767	731
0.90	777	253	1292	442	1524	572	1513	581	1732	758
1.00	718	278	1258	453	1487	580	1482	588	1703	777
1.10	692	272	1152	498	1451	613	1452	599	1681	788
1.20	666	293	1115	507	1429	624	1412	627	1639	783

NOTE - All air data measured external to unit with dry coil and 1 inch non-pleated air filter in place.
Electric heaters have no appreciable air resistance.

BLOWER DATA

7AH2AE-060 BLOWER PERFORMANCE

External Static Pressure in. w.g.	Air Volume and Motor Watts									
	Tap 1		Tap 2		Tap 3		Tap 4		Tap 5	
	cfm	Watts	cfm	Watts	cfm	Watts	cfm	Watts	cfm	Watts
0.10	1354	222	1768	454	1954	616	1870	550	2148	808
0.20	1307	240	1742	478	1929	627	1845	556	2124	846
0.30	1267	246	1706	479	1898	643	1817	581	2097	843
0.40	1222	263	1677	492	1861	675	1781	609	2058	859
0.50	1177	273	1644	511	1837	693	1759	616	2034	888
0.60	1150	289	1608	526	1814	703	1719	635	2019	894
0.70	1044	308	1577	555	1786	687	1671	661	1975	912
0.80	994	311	1537	577	1773	710	1645	680	1938	930
0.90	938	317	1516	561	1712	736	1639	666	1927	938
1.00	877	330	1475	590	1696	753	1613	687	1892	943
1.10	846	346	1418	619	1677	755	1567	713	1836	945
1.20	816	345	1392	626	1648	765	1526	719	1795	940

NOTE - All air data measured external to unit with dry coil and 1 inch non-pleated air filter in place.
Electric heaters have no appreciable air resistance.

REPLACEMENT CIRCUIT BREAKERS

Voltage	Description	Catalog No.	Voltage	Description	Catalog No.
208/240V - 1 Phase	25 amp, 2 pole	41K13	208/240V - 3 Phase	30 amp, 3 pole	64W47
	30 amp, 2 pole	17K70		35 amp, 3 pole	41K14
	35 amp, 2 pole	72K07		40 amp, 3 pole	41K16
	40 amp, 2 pole	49K14		45 amp, 3 pole	18M86
	45 amp, 2 pole	17K71		50 amp, 3 pole	41K15
	50 amp, 2 pole	41K12		60 amp, 3 pole	41K17
	60 amp, 2 pole	17K72			

ELECTRIC HEAT DATA

7AH2AE-018 | SINGLE PHASE

Electric Heat Model Number	No. of Stages	Input			² Blower Motor Full Load Amps	³ Minimum Circuit Ampacity	⁵ Maximum Overcurrent Protection
		Volts	kW	¹ Btuh			
5 kW 4 lbs. ECB47-5 (27A31) Terminal Block ECB47-5CB (27A24) 35A Circuit breaker	1	208	3.8	12,800	4.1	28	⁴ 30
		220	4.2	14,300	4.1	31	35
		230	4.6	15,700	4.1	31	35
		240	5.0	17,100	4.1	31	35
6 kW 4 lbs. ECB47-6 (27A26) Terminal Block ECB47-6CB (27A25) 40A Circuit breaker	1	208	4.5	15,400	4.1	32	⁴ 35
		220	5.0	17,100	4.1	36	40
		230	5.5	18,800	4.1	36	40
		240	6.0	20,500	4.1	36	40
8 kW 5 lbs. ECB47-8 (27A21) Terminal Block ECB47-8CB (27A32) 50A Circuit breaker	1	208	6.0	20,500	4.1	41	⁴ 45
		220	6.7	22,900	4.1	47	50
		230	7.3	25,100	4.1	47	50
		240	8.0	27,300	4.1	47	50
9 kW 5 lbs. ECB47-9 (27A22) Terminal Block ECB47-9CB (27A27) 60A Circuit breaker	2	208	6.8	23,100	4.1	46	⁴ 50
		220	7.6	25,800	4.1	52	60
		230	8.3	28,200	4.1	52	60
		240	9.0	30,700	4.1	52	60

NOTE - Circuit 1 Minimum Circuit Ampacity includes the Blower Motor Full Load Amps.

¹ Electric heater capacity only - does not include additional blower motor heat capacity.

² Amps shown are for blower motor only.

³ Refer to National or Canadian Electrical Code manual to determine wire, fuse and disconnect size requirements. Use wires suitable for at least 167°F.

⁴ Bold text indicates that the circuit breaker on "CB" circuit breaker models must be replaced with size noted. See Table on Page 10.

⁵ HACR type circuit breaker or fuse.

ELECTRIC HEAT DATA

7AH2AE-024 | SINGLE PHASE

Electric Heat Model Number	No. of Stages	Input			² Blower Motor Full Load Amps	³ Minimum Circuit Ampacity	⁵ Maximum Overcurrent Protection
		Volts	kW	¹ Btuh			
5 kW 4 lbs. ECB47-5 (27A31) Terminal Block ECB47-5CB (27A24) 35A Circuit breaker	1	208	3.8	12,800	4.1	28	⁴ 30
		220	4.2	14,300	4.1	31	35
		230	4.6	15,700	4.1	31	35
		240	5.0	17,100	4.1	31	35
6 kW 4 lbs. ECB47-6 (27A26) Terminal Block ECB47-6CB (27A25) 40A Circuit breaker	1	208	4.5	15,400	4.1	32	⁴ 35
		220	5.0	17,100	4.1	36	40
		230	5.5	18,800	4.1	36	40
		240	6.0	20,500	4.1	36	40
8 kW 5 lbs. ECB47-8 (27A21) Terminal Block ECB47-8CB (27A32) 50A Circuit breaker	1	208	6.0	20,500	4.1	41	⁴ 45
		220	6.7	22,900	4.1	47	50
		230	7.3	25,100	4.1	47	50
		240	8.0	27,300	4.1	47	50
9 kW 5 lbs. ECB47-9CB (27A27) 60A Circuit breaker	2	208	6.8	23,100	4.1	46	⁴ 50
		220	7.6	25,800	4.1	52	60
		230	8.3	28,200	4.1	52	60
		240	9.0	30,700	4.1	52	60

NOTE - Circuit 1 Minimum Circuit Ampacity includes the Blower Motor Full Load Amps.

¹ Electric heater capacity only - does not include additional blower motor heat capacity.

² Amps shown are for blower motor only.

³ Refer to National or Canadian Electrical Code manual to determine wire, fuse and disconnect size requirements. Use wires suitable for at least 167°F.

⁴ Bold text indicates that the circuit breaker on "CB" circuit breaker models must be replaced with size noted. See Table on Page 10.

⁵ HACR type circuit breaker or fuse.

ELECTRIC HEAT DATA

7AH2AE-030 | SINGLE PHASE

kW	Electic Heat Model Number	No. of Stages	Input			² Blower Motor Full Load Amps	³ Minimum Circuit Ampacity		⁵ Maximum Overcurrent Protection		Single Point Power Source	
			Volts	kW	¹ Btuh		Ckt 1	Ckt 2	Ckt 1	Ckt 2	³ Minimum Circuit Ampacity	⁵ Maximum Overcurrent Protection
5 kW 4 lbs.	ECB47-5 (27A31) Terminal Block ECB47-5CB (27A24) 35A Circuit breaker	1	208	3.8	12,800	4.1	28	---	4 30	---	---	---
			220	4.2	14,300	4.1	31	---	35	---	---	---
			230	4.6	15,700	4.1	31	---	35	---	---	---
			240	5.0	17,100	4.1	31	---	35	---	---	---
6 kW 4 lbs.	ECB47-6 (27A26) Terminal Block ECB47-6CB (27A25) 40A Circuit breaker	1	208	4.5	15,400	4.1	32	---	4 35	---	---	---
			220	5.0	17,100	4.1	36	---	40	---	---	---
			230	5.5	18,800	4.1	36	---	40	---	---	---
			240	6.0	20,500	4.1	36	---	40	---	---	---
8 kW 5 lbs.	ECB47-8 (27A21) Terminal Block ECB47-8CB (27A32) 50A Circuit breaker	1	208	6.0	20,500	4.1	41	---	4 45	---	---	---
			220	6.7	22,900	4.1	47	---	50	---	---	---
			230	7.3	25,100	4.1	47	---	50	---	---	---
			240	8.0	27,300	4.1	47	---	50	---	---	---
9 kW 5 lbs.	ECB47-9 (27A22) Terminal Block ECB47-9CB (27A27) 60A Circuit breaker	2	208	6.8	23,100	4.1	46	---	4 50	---	---	---
			220	7.6	25,800	4.1	52	---	60	---	---	---
			230	8.3	28,200	4.1	52	---	60	---	---	---
			240	9.0	30,700	4.1	52	---	60	---	---	---
12.5 kW 10 lbs.	ECB47-12.5CB (27A28) (1) 30A Circuit breaker & (1) 45A Circuit breaker	2	208	9.4	32,000	4.1	24	38	4 25	4 40	62	70
			220	10.5	35,800	4.1	27	43	30	45	70	70
			230	11.5	39,200	4.1	27	43	30	45	70	70
			240	12.5	42,600	4.1	27	43	30	45	70	70
15 kW 12 lbs.	ECB47-15CB (27A23) (1) 35A Circuit breaker & (1) 60A Circuit Breaker	2	208	11.3	38,400	4.1	28	45	4 30	4 45	73	80
			220	12.6	43,000	4.1	31	52	35	60	83	90
			230	13.8	47,000	4.1	31	52	35	60	83	90
			240	15.0	51,200	4.1	31	52	35	60	83	90

THREE PHASE

8 kW 5 lbs.	ECB47-8 (27A44) Terminal Block	1	208	6.0	20,500	4.1	26	---	30	---	---	---
			220	6.7	22,900	4.1	29	---	30	---	---	---
			230	7.3	25,100	4.1	29	---	30	---	---	---
			240	8.0	27,300	4.1	29	---	30	---	---	---
10 kW 6 lbs.	ECB47-10 (27A35) Terminal Block	1	208	7.5	25,600	4.1	31	---	35	---	---	---
			220	8.4	28,700	4.1	35	---	35	---	---	---
			230	9.2	31,400	4.1	35	---	35	---	---	---
			240	10.0	34,100	4.1	35	---	35	---	---	---
15 kW 12 lbs.	ECB47-15CB (27A36) (1) 50A Circuit breaker	1	208	11.3	38,400	4.1	44	---	45	---	---	---
			220	12.6	43,000	4.1	50	---	50	---	---	---
			230	13.5	47,000	4.1	50	---	50	---	---	---
			240	15.0	51,200	4.1	50	---	50	---	---	---

NOTE - Circuit 1 Minimum Circuit Ampacity includes the Blower Motor Full Load Amps.

¹ Electric heater capacity only - does not include additional blower motor heat capacity.

² Amps shown are for blower motor only.

³ Refer to National or Canadian Electrical Code manual to determine wire, fuse and disconnect size requirements. Use wires suitable for at least 167°F.

⁴ Bold text indicates that the circuit breaker on "CB" circuit breaker models must be replaced with size noted. See Table on Page 10.

⁵ HACR type circuit breaker or fuse.

ELECTRIC HEAT DATA

7AH2AE-036 | SINGLE PHASE

Electric Heat Model Number	No. of Stages	Input			² Blower Motor Full Load Amps	³ Minimum Circuit Ampacity		⁵ Maximum Overcurrent Protection		Single Point Power Source	
		Volts	kW	¹ Btuh		Ckt 1	Ckt 2	Ckt 1	Ckt 2	³ Minimum Circuit Ampacity	⁵ Maximum Overcurrent Protection
5 kW 4 lbs. ECB47-5 (27A31) Terminal Block ECB47-5CB (27A24) 35A Circuit breaker	1	208	3.8	12,800	4.1	28	---	430	---	---	---
		220	4.2	14,300	4.1	31	---	35	---	---	---
		230	4.6	15,700	4.1	31	---	35	---	---	---
		240	5.0	17,100	4.1	31	---	35	---	---	---
6 kW 4 lbs. ECB47-6 (27A26) Terminal Block ECB47-6CB (27A25) 40A Circuit breaker	1	208	4.5	15,400	4.1	32	---	435	---	---	---
		220	5.0	17,100	4.1	36	---	40	---	---	---
		230	5.5	18,800	4.1	36	---	40	---	---	---
		240	6.0	20,500	4.1	36	---	40	---	---	---
8 kW 5 lbs. ECB47-8 (27A21) Terminal Block ECB47-8CB (27A32) 50A Circuit breaker	1	208	6.0	20,500	4.1	41	---	445	---	---	---
		220	6.7	22,900	4.1	47	---	50	---	---	---
		230	7.3	25,100	4.1	47	---	50	---	---	---
		240	8.0	27,300	4.1	47	---	50	---	---	---
9 kW 5 lbs. ECB47-9 (27A22) Terminal Block ECB47-9CB (27A27) 60A Circuit breaker	2	208	6.8	23,100	4.1	46	---	450	---	---	---
		220	7.6	25,800	4.1	52	---	60	---	---	---
		230	8.3	28,200	4.1	52	---	60	---	---	---
		240	9.0	30,700	4.1	52	---	60	---	---	---
12.5 kW 10 lbs. ECB47-12.5CB (27A28) (1) 30A Circuit breaker and (1) 45A Circuit breaker	2	208	9.4	32,000	4.1	24	38	425	440	62	70
		220	10.5	35,800	4.1	27	43	30	45	70	70
		230	11.5	39,200	4.1	27	43	30	45	70	70
		240	12.5	42,600	4.1	27	43	30	45	70	70
15 kW 12 lbs. (1) 35A Circuit breaker and (1) 60A Circuit Breaker	2	208	11.3	38,400	4.1	28	45	430	445	73	80
		220	12.6	43,000	4.1	31	52	35	60	83	90
		230	13.8	47,000	4.1	31	52	35	60	83	90
		240	15.0	51,200	4.1	31	52	35	60	83	90
20 kW 19 lbs. (1) 60A Circuit breaker and (1) 60A Circuit Breaker	2	208	15.0	51,200	4.1	46	50	450	450	96	100
		220	16.8	57,300	4.1	52	57	60	60	109	125
		230	18.4	62,700	4.1	52	57	60	60	109	125
		240	20.0	68,200	4.1	52	57	60	60	109	125

NOTE - Circuit 1 Minimum Circuit Ampacity includes the Blower Motor Full Load Amps.

¹ Electric heater capacity only - does not include additional blower motor heat capacity.

² Amps shown are for blower motor only.

³ Refer to National or Canadian Electrical Code manual to determine wire, fuse and disconnect size requirements. Use wires suitable for at least 167°F.

⁴ Bold text indicates that the circuit breaker on "CB" circuit breaker models must be replaced with size noted. See Table on Page 10.

⁵ HACR type circuit breaker or fuse.

ELECTRIC HEAT DATA

7AH2AE-036 | THREE PHASE

Electric Heat Model Number	No. of Stages	Input			² Blower Motor Full Load Amps	³ Minimum Circuit Ampacity		⁵ Maximum Overcurrent Protection		Single Point Power Source	
		Volts	kW	¹ Btuh		Ckt 1	Ckt 2	Ckt 1	Ckt 2	³ Minimum Circuit Ampacity	⁵ Maximum Overcurrent Protection
8 kW 5 lbs. ECB47-8 (27A44) Terminal Block	1	208	6.0	20,500	4.1	26	---	30	---	---	---
		220	6.7	22,900	4.1	29	---	30	---	---	---
		230	7.3	25,100	4.1	29	---	30	---	---	---
		240	8.0	27,300	4.1	29	---	30	---	---	---
10 kW 6 lbs. ECB47-10 (27A35) Terminal Block	1	208	7.5	25,600	4.1	31	---	35	---	---	---
		220	8.4	28,700	4.1	35	---	35	---	---	---
		230	9.2	31,400	4.1	35	---	35	---	---	---
		240	10.0	34,100	4.1	35	---	35	---	---	---
15 kW 12 lbs. ECB47-15CB (27A36) (1) 50A Circuit breaker	1	208	11.3	38,400	4.1	44	---	45	---	---	---
		220	12.6	43,000	4.1	50	---	50	---	---	---
		230	13.5	47,000	4.1	50	---	50	---	---	---
		240	15.0	51,200	4.1	50	---	50	---	---	---
20 kW 19 lbs. ECB47-20CB (27A37) (2) 35A Circuit breaker	2	208	15.0	51,200	4.1	31	26	35	30	57	60
		220	16.8	57,300	4.1	35	30	35	30	65	70
		230	18.4	62,700	4.1	35	30	35	30	65	70
		240	20.0	68,200	4.1	35	30	35	30	65	70

NOTE - Circuit 1 Minimum Circuit Ampacity includes the Blower Motor Full Load Amps.

¹ Electric heater capacity only - does not include additional blower motor heat capacity.

² Amps shown are for blower motor only.

³ Refer to National or Canadian Electrical Code manual to determine wire, fuse and disconnect size requirements. Use wires suitable for at least 167°F.

⁴ Bold text indicates that the circuit breaker on "CB" circuit breaker models must be replaced with size noted. See Table on Page 10.

⁵ HACR type circuit breaker or fuse.

ELECTRIC HEAT DATA

7AH2AE-042 | SINGLE PHASE

Electric Heat Model Number	No. of Stages	Input			² Blower Motor Full Load Amps	³ Minimum Circuit Ampacity			⁵ Maximum Overcurrent Protection			Single Point Power Source	
		Volts	kW	¹ Btuh		Ckt 1	Ckt 2	Ckt 3	Ckt 1	Ckt 2	Ckt 3	³ Minimum Circuit Ampacity	⁵ Maximum Overcurrent Protection
5 kW 4 lbs. ECB47-5 (27A31) Terminal Block ECB47-5CB (27A24) 35A Circuit breaker	1	208	3.8	12,800	7.6	32	---	---	35	---	---	---	---
		220	4.2	14,300	7.6	36	---	---	⁴ 40	---	---	---	---
		230	4.6	15,700	7.6	36	---	---	⁴ 40	---	---	---	---
		240	5.0	17,100	7.6	36	---	---	⁴ 40	---	---	---	---
6 kW 4 lbs. ECB47-6 (27A26) Terminal Block ECB47-6CB (27A25) 40A Circuit breaker	1	208	4.5	15,400	7.6	37	---	---	40	---	---	---	---
		220	5.0	17,100	7.6	41	---	---	⁴ 45	---	---	---	---
		230	5.5	18,800	7.6	41	---	---	⁴ 45	---	---	---	---
		240	6.0	20,500	7.6	41	---	---	⁴ 45	---	---	---	---
8 kW 5 lbs. ECB47-8 (27A21) Terminal Block ECB47-8CB (27A32) 50A Circuit breaker	1	208	6.0	20,500	7.6	46	---	---	50	---	---	---	---
		220	6.7	22,900	7.6	51	---	---	⁴ 60	---	---	---	---
		230	7.3	25,100	7.6	51	---	---	⁴ 60	---	---	---	---
		240	8.0	27,300	7.6	51	---	---	⁴ 60	---	---	---	---
9 kW 5 lbs. ECB47-9 (27A22) Terminal Block ECB47-9CB (27A27) 60A Circuit breaker	2	208	6.8	23,100	7.6	50	---	---	⁴ 50	---	---	---	---
		220	7.6	25,800	7.6	56	---	---	60	---	---	---	---
		230	8.3	28,200	7.6	56	---	---	60	---	---	---	---
		240	9.0	30,700	7.6	56	---	---	60	---	---	---	---
12.5 kW 10 lbs. ECB47-12.5CB (27A28) (1) 30A Circuit breaker and (1) 45A Circuit breaker	2	208	9.4	32,000	7.6	28	38	---	30	⁴ 40	---	66	80
		220	10.5	35,800	7.6	31	43	---	⁴ 35	45	---	75	80
		230	11.5	39,200	7.6	31	43	---	⁴ 35	45	---	75	80
		240	12.5	42,600	7.6	31	43	---	⁴ 35	45	---	75	80
15 kW 12 lbs. ECB47-15CB (27A23) (1) 35A Circuit breaker and (1) 60A Circuit breaker	2	208	11.3	38,400	7.6	32	45	---	35	⁴ 45	---	77	80
		220	12.6	43,000	7.6	36	52	---	⁴ 40	60	---	88	90
		230	13.5	47,000	7.6	36	52	---	⁴ 40	60	---	88	90
		240	15.0	51,200	7.6	36	52	---	⁴ 40	60	---	88	90
20 kW 19 lbs. ECB47-20CB (27A33) (1) 60A Circuit breaker and (1) 60A Circuit breaker	2	208	15.0	51,200	7.6	50	50	---	⁴ 50	⁴ 50	---	100	125
		220	16.8	57,300	7.6	56	57	---	60	60	---	114	125
		230	18.4	62,700	7.6	56	57	---	60	60	---	114	125
		240	20.0	68,200	7.6	56	57	---	60	60	---	114	125
25 kW 19 lbs. ECB47-25CB (27A34) (1) 60A Circuit breaker and (2) 45A Circuit breakers	3	208	18.8	64,100	7.6	47	38	38	⁴ 50	⁴ 40	⁴ 40	123	125
		220	21.0	71,700	7.6	53	43	43	60	45	45	140	150
		230	23.0	78,300	7.6	53	43	43	60	45	45	140	150
		240	25.0	85,300	7.6	53	43	43	60	45	45	140	150

¹ Electric heater capacity only - does not include additional blower motor heat capacity.

² Amps shown are for blower motor only.

³ Refer to National or Canadian Electrical Code manual to determine wire, fuse and disconnect size requirements. Use wires suitable for at least 167°F.

⁴ Bold text indicates that the circuit breaker on "CB" circuit breaker models must be replaced with size noted. See Table on Page 10.

⁵ HACR type circuit breaker or fuse.

ELECTRIC HEAT DATA

7AH2AE-042 | THREE PHASE

Electric Heat Model Number	No. of Stages	Input			² Blower Motor Full Load Amps	³ Minimum Circuit Ampacity		⁵ Maximum Overcurrent Protection		Single Point Power Source	
		Volts	kW	¹ Btuh		Ckt 1	Ckt 2	Ckt 1	Ckt 2	³ Minimum Circuit Ampacity	⁵ Maximum Overcurrent Protection
8 kW 5 lbs. ECB47-8 (27A44) Terminal block	1	208	6.0	20,500	7.6	30	---	30	---	---	---
		220	6.7	22,900	7.6	33	---	35	---	---	---
		230	7.3	25,100	7.6	33	---	35	---	---	---
		240	8.0	27,300	7.6	33	---	35	---	---	---
10 kW 6 lbs. ECB47-10 (27A35) Terminal Block	1	208	7.5	25,600	7.6	36	---	40	---	---	---
		220	8.4	28,700	7.6	40	---	40	---	---	---
		230	9.2	31,400	7.6	40	---	40	---	---	---
		240	10.0	34,100	7.6	40	---	40	---	---	---
15 kW 12 lbs. ECB47-15CB (27A36) 50A Circuit breaker	1	208	11.3	38,400	7.6	49	---	50	---	---	---
		220	12.6	43,000	7.6	55	---	460	---	---	---
		230	13.5	47,000	7.6	55	---	460	---	---	---
		240	15.0	51,200	7.6	55	---	460	---	---	---
20 kW 19 lbs. ECB47-20CB (27A37) (2) 35A Circuit breaker	2	208	15.0	51,200	7.6	36	26	440	430	62	70
		220	16.8	57,300	7.6	40	30	440	430	70	70
		230	18.4	62,700	7.6	40	30	440	430	70	70
		240	20.0	68,200	7.6	40	30	440	430	70	70
25 kW 19 lbs. ECB47-25CB (27A45) (2) 45A Circuit breaker	2	208	18.8	64,100	7.6	42	33	450	435	62	70
		220	21.0	71,700	7.6	47	38	450	440	85	90
		230	23.0	78,300	7.6	47	38	450	440	85	90
		240	25.0	85,300	7.6	47	38	450	440	85	90

NOTE - Circuit 1 Minimum Circuit Ampacity includes the Blower Motor Full Load Amps.

¹ Electric heater capacity only - does not include additional blower motor heat capacity.

² Amps shown are for blower motor only.

³ Refer to National or Canadian Electrical Code manual to determine wire, fuse and disconnect size requirements. Use wires suitable for at least 167°F.

⁴ Bold text indicates that the circuit breaker on "CB" circuit breaker models must be replaced with size noted. See Table on Page 10.

⁵ HACR type circuit breaker or fuse.

ELECTRIC HEAT DATA

7AH2AE-048 | SINGLE PHASE

Electric Heat Model Number	No. of Stages	Input			² Blower Motor Full Load Amps	³ Minimum Circuit Ampacity			⁵ Maximum Overcurrent Protection			Single Point Power Source	
		Volts	kW	¹ Btuh		Ckt 1	Ckt 2	Ckt 3	Ckt 1	Ckt 2	Ckt 3	³ Minimum Circuit Ampacity	⁵ Maximum Overcurrent Protection
5 kW 4 lbs. ECB47-5 (27A31) Terminal Block ECB47-5CB (27A24) 35A Circuit breaker	1	208	3.8	12,800	7.6	32	---	---	35	---	---	---	---
		220	4.2	14,300	7.6	36	---	---	⁴ 40	---	---	---	---
		230	4.6	15,700	7.6	36	---	---	⁴ 40	---	---	---	---
		240	5.0	17,100	7.6	36	---	---	⁴ 40	---	---	---	---
6 kW 4 lbs. ECB47-6 (27A26) Terminal Block ECB47-6CB (27A26) 40A Circuit breaker	1	208	4.5	15,400	7.6	37	---	---	40	---	---	---	---
		220	5.0	17,100	7.6	41	---	---	⁴ 45	---	---	---	---
		230	5.5	18,800	7.6	41	---	---	⁴ 45	---	---	---	---
		240	6.0	20,500	7.6	41	---	---	⁴ 45	---	---	---	---
8 kW 5 lbs. ECB47-8 (27A25) Terminal Block ECB47-8CB (27A32) 50A Circuit breaker	1	208	6.0	20,500	7.6	46	---	---	50	---	---	---	---
		220	6.7	22,900	7.6	51	---	---	⁴ 60	---	---	---	---
		230	7.3	25,100	7.6	51	---	---	⁴ 60	---	---	---	---
		240	8.0	27,300	7.6	51	---	---	⁴ 60	---	---	---	---
9 kW 5 lbs. ECB47-9 (27A22) Terminal Block ECB47-9CB (27A27) 60A Circuit breaker	2	208	6.8	23,100	7.6	50	---	---	⁴ 50	---	---	---	---
		220	7.6	25,800	7.6	56	---	---	60	---	---	---	---
		230	8.3	28,200	7.6	56	---	---	60	---	---	---	---
		240	9.0	30,700	7.6	56	---	---	60	---	---	---	---
12.5 kW 10 lbs. ECB47-12.5CB (27A28) (1) 30A Circuit breaker & (1) 45A Circuit breaker	2	208	9.4	32,000	7.6	28	38	---	30	⁴ 40	---	66	70
		220	10.5	35,800	7.6	31	43	---	⁴ 35	45	---	75	80
		230	11.5	39,200	7.6	31	43	---	⁴ 35	45	---	75	80
		240	12.5	42,600	7.6	31	43	---	⁴ 35	45	---	75	80
15 kW 12 lbs. ECB47-15CB (27A23) (1) 35A Circuit breaker & (1) 60A Circuit breaker	2	208	11.3	38,400	7.6	32	45	---	35	⁴ 45	---	77	80
		220	12.6	43,000	7.6	36	52	---	⁴ 40	60	---	88	90
		230	13.5	47,000	7.6	36	52	---	⁴ 40	60	---	88	90
		240	15.0	51,200	7.6	36	52	---	⁴ 40	60	---	88	90
20 kW 19 lbs. ECB47-20CB (27A33) (1) 60A Circuit breaker & (1) 60A Circuit breaker	2	208	15.0	51,200	7.6	50	50	---	⁴ 50	⁴ 50	---	100	125
		220	16.8	57,300	7.6	56	57	---	60	60	---	114	125
		230	18.4	62,700	7.6	56	57	---	60	60	---	114	125
		240	20.0	68,200	7.6	56	57	---	60	60	---	114	125
25 kW 19 lbs. ECB47-25CB (27A34) (1) 60A Circuit breaker & (2) 45A Circuit breakers	3	208	18.8	64,100	7.6	47	38	38	⁴ 50	⁴ 40	⁴ 40	123	125
		220	21.0	71,700	7.6	53	43	43	60	45	45	140	150
		230	23.0	78,300	7.6	53	43	43	60	45	45	140	150
		240	25.0	85,300	7.6	53	43	43	60	45	45	140	150

NOTE - Circuit 1 Minimum Circuit Ampacity includes the Blower Motor Full Load Amps.

¹ Electric heater capacity only - does not include additional blower motor heat capacity.

² Amps shown are for blower motor only.

³ Refer to National or Canadian Electrical Code manual to determine wire, fuse and disconnect size requirements. Use wires suitable for at least 167°F.

⁴ Bold text indicates that the circuit breaker on "CB" circuit breaker models must be replaced with size noted. See Table on Page 10.

⁵ HACR type circuit breaker or fuse.

ELECTRIC HEAT DATA

7AH2AE-048 | THREE PHASE

Electric Heat Model Number	No. of Stages	Input			² Blower Motor Full Load Amps	³ Minimum Circuit Ampacity		⁵ Maximum Overcurrent Protection		Single Point Power Source	
		Volts	kW	¹ Btuh		Ckt 1	Ckt 2	Ckt 1	Ckt 2	³ Minimum Circuit Ampacity	⁵ Maximum Overcurrent Protection
8 kW 5 lbs. ECB47-8 (27A44) Terminal block	1	208	6.0	20,500	7.6	30	---	30	---	---	---
		220	6.7	22,900	7.6	33	---	35	---	---	---
		230	7.3	25,100	7.6	33	---	35	---	---	---
		240	8.0	27,300	7.6	33	---	35	---	---	---
10 kW 6 lbs. ECB47-10 (27A35) Terminal Block	1	208	7.5	25,600	7.6	36	---	40	---	---	---
		220	8.4	28,700	7.6	40	---	40	---	---	---
		230	9.2	31,400	7.6	40	---	40	---	---	---
		240	10.0	34,100	7.6	40	---	40	---	---	---
15 kW 12 lbs. ECB47-15CB (27A36) 50A Circuit breaker	1	208	11.3	38,400	7.6	49	---	50	---	---	---
		220	12.6	43,000	7.6	55	---	40	---	---	---
		230	13.5	47,000	7.6	55	---	40	---	---	---
		240	15.0	51,200	7.6	55	---	40	---	---	---
20 kW 19 lbs. ECB47-20CB (27A37) (2) 35A Circuit breaker	2	208	15.0	51,200	7.6	36	26	40	30	62	70
		220	16.8	57,300	7.6	40	30	40	30	70	70
		230	18.4	62,700	7.6	40	30	40	30	70	70
		240	20.0	68,200	7.6	40	30	40	30	70	70
25 kW 19 lbs. ECB47-25CB (27A45) (2) 45A Circuit breaker	2	208	18.8	64,100	7.6	42	33	50	35	75	80
		220	21.0	71,700	7.6	47	38	50	40	85	90
		230	23.0	78,300	7.6	47	38	50	40	85	90
		240	25.0	85,300	7.6	47	38	50	40	85	90

NOTE - Circuit 1 Minimum Circuit Ampacity includes the Blower Motor Full Load Amps.

¹ Electric heater capacity only - does not include additional blower motor heat capacity.

² Amps shown are for blower motor only.

³ Refer to National or Canadian Electrical Code manual to determine wire, fuse and disconnect size requirements. Use wires suitable for at least 167°F.

⁴ Bold text indicates that the circuit breaker on "CB" circuit breaker models must be replaced with size noted. See Table on Page 10.

⁵ HACR type circuit breaker or fuse.

ELECTRIC HEAT DATA

7AH2AE-060 | SINGLE PHASE

Electric Heat Model Number	No. of Stages	Input			² Blower Motor Full Load Amps	³ Minimum Circuit Ampacity			⁵ Maximum Overcurrent Protection			Single Point Power Source	
		Volts	kW	¹ Btuh		Ckt 1	Ckt 2	Ckt 3	Ckt 1	Ckt 2	Ckt 3	³ Minimum Circuit Ampacity	⁵ Maximum Overcurrent Protection
5 kW 4 lbs. ECB47-5 (27A31) Terminal Block ECB47-5CB (27A24) 35A Circuit breaker	1	208	3.8	12,800	7.6	32	---	---	35	---	---	---	---
		220	4.2	14,300	7.6	36	---	---	⁴ 40	---	---	---	---
		230	4.6	15,700	7.6	36	---	---	⁴ 40	---	---	---	---
		240	5.0	17,100	7.6	36	---	---	⁴ 40	---	---	---	---
6 kW 4 lbs. ECB47-6 (27A26) Terminal Block ECB47-6CB (27A25) 40A Circuit breaker	1	208	4.5	15,400	7.6	37	---	---	40	---	---	---	---
		220	5.0	17,100	7.6	41	---	---	⁴ 45	---	---	---	---
		230	5.5	18,800	7.6	41	---	---	⁴ 45	---	---	---	---
		240	6.0	20,500	7.6	41	---	---	⁴ 45	---	---	---	---
8 kW 5 lbs. ECB47-8 (27A21) Terminal Block ECB47-8CB (27A32) 50A Circuit breaker	1	208	6.0	20,500	7.6	46	---	---	50	---	---	---	---
		220	6.7	22,900	7.6	51	---	---	⁴ 60	---	---	---	---
		230	7.3	25,100	7.6	51	---	---	⁴ 60	---	---	---	---
		240	8.0	27,300	7.6	51	---	---	⁴ 60	---	---	---	---
9 kW 5 lbs. ECB47-9 (27A22) Terminal Block ECB47-9CB (27A27) 60A Circuit breaker	2	208	6.8	23,100	7.6	50	---	---	⁴ 50	---	---	---	---
		220	7.6	25,800	7.6	56	---	---	60	---	---	---	---
		230	8.3	28,200	7.6	56	---	---	60	---	---	---	---
		240	9.0	30,700	7.6	56	---	---	60	---	---	---	---
12.5 kW 10 lbs. ECB47-12.5CB (27A28) (1) 30A Circuit breaker & (1) 45A Circuit breaker	2	208	9.4	32,000	7.6	28	38	---	30	⁴ 40	---	66	70
		220	10.5	35,800	7.6	31	43	---	⁴ 35	45	---	75	80
		230	11.5	39,200	7.6	31	43	---	⁴ 35	45	---	75	80
		240	12.5	42,600	7.6	31	43	---	⁴ 35	45	---	75	80
15 kW 12 lbs. ECB47-15CB (27A23) (1) 35A Circuit breaker & (1) 60A Circuit breaker	2	208	11.3	38,400	7.6	32	45	---	35	⁴ 45	---	77	80
		220	12.6	43,000	7.6	36	52	---	⁴ 40	60	---	88	90
		230	13.5	47,000	7.6	36	52	---	⁴ 40	60	---	88	90
		240	15.0	51,200	7.6	36	52	---	⁴ 40	60	---	88	90
20 kW 19 lbs. ECB47-20CB (27A33) (1) 60A Circuit breaker & (1) 60A Circuit breaker	2	208	15.0	51,200	7.6	50	50	---	⁴ 50	⁴ 50	---	100	125
		220	16.8	57,300	7.6	56	57	---	60	60	---	114	125
		230	18.4	62,700	7.6	56	57	---	60	60	---	114	125
		240	20.0	68,200	7.6	56	57	---	60	60	---	114	125
25 kW 19 lbs. ECB47-25CB (27A34) (1) 60A Circuit breaker & (2) 45A Circuit breakers	3	208	18.8	64,100	7.6	47	38	38	⁴ 50	⁴ 40	⁴ 40	123	125
		220	21.0	71,700	7.6	53	43	43	60	45	45	140	150
		230	23.0	78,300	7.6	53	43	43	60	45	45	140	150
		240	25.0	85,300	7.6	53	43	43	60	45	45	140	150

NOTE - Circuit 1 Minimum Circuit Ampacity includes the Blower Motor Full Load Amps.

¹ Electric heater capacity only - does not include additional blower motor heat capacity.

² Amps shown are for blower motor only.

³ Refer to National or Canadian Electrical Code manual to determine wire, fuse and disconnect size requirements. Use wires suitable for at least 167°F.

⁴ Bold text indicates that the circuit breaker on "CB" circuit breaker models must be replaced with size noted. See Table on Page 10.

⁵ HACR type circuit breaker or fuse.

ELECTRIC HEAT DATA

7AH2AE-060 | THREE PHASE

Electric Heat Model Number	No. of Stages	Input			² Blower Motor Full Load Amps	³ Minimum Circuit Ampacity		⁵ Maximum Overcurrent Protection		Single Point Power Source	
		Volts	kW	¹ Btuh		Ckt 1	Ckt 2	Ckt 1	Ckt 2	³ Minimum Circuit Ampacity	⁵ Maximum Overcurrent Protection
8 kW 5 lbs. ECB47-8 (27A44) Terminal block	1	208	6.0	20,500	7.6	30	---	30	---	---	---
		220	6.7	22,900	7.6	33	---	35	---	---	---
		230	7.3	25,100	7.6	33	---	35	---	---	---
		240	8.0	27,300	7.6	33	---	35	---	---	---
10 kW 6 lbs. ECB47-10 (27A35) Terminal Block	1	208	7.5	25,600	7.6	36	---	40	---	---	---
		220	8.4	28,700	7.6	40	---	40	---	---	---
		230	9.2	31,400	7.6	40	---	40	---	---	---
		240	10.0	34,100	7.6	40	---	40	---	---	---
15 kW 12 lbs. ECB47-15CB (27A36) 50A Circuit breaker	1	208	11.3	38,400	7.6	49	---	50	---	---	---
		220	12.6	43,000	7.6	55	---	40	---	---	---
		230	13.5	47,000	7.6	55	---	40	---	---	---
		240	15.0	51,200	7.6	55	---	40	---	---	---
20 kW 19 lbs. ECB47-20CB (27A37) (2) 35A Circuit breaker	2	208	15.0	51,200	7.6	36	26	40	30	62	70
		220	16.8	57,300	7.6	40	30	40	30	70	70
		230	18.4	62,700	7.6	40	30	40	30	70	70
		240	20.0	68,200	7.6	40	30	40	30	70	70
25 kW 19 lbs. ECB47-25CB (27A45) (2) 45A Circuit breaker	2	208	18.8	64,100	7.6	42	33	45	35	75	80
		220	21.0	71,700	7.6	47	38	50	40	85	90
		230	23.0	78,300	7.6	47	38	50	40	85	90
		240	25.0	85,300	7.6	47	38	50	40	85	90

NOTE - Circuit 1 Minimum Circuit Ampacity includes the Blower Motor Full Load Amps.

¹ Electric heater capacity only - does not include additional blower motor heat capacity.

² Amps shown are for blower motor only.

³ Refer to National or Canadian Electrical Code manual to determine wire, fuse and disconnect size requirements. Use wires suitable for at least 167°F.

⁴ Bold text indicates that the circuit breaker on "CB" circuit breaker models must be replaced with size noted. See Table on Page 10.

⁵ HACR type circuit breaker or fuse.

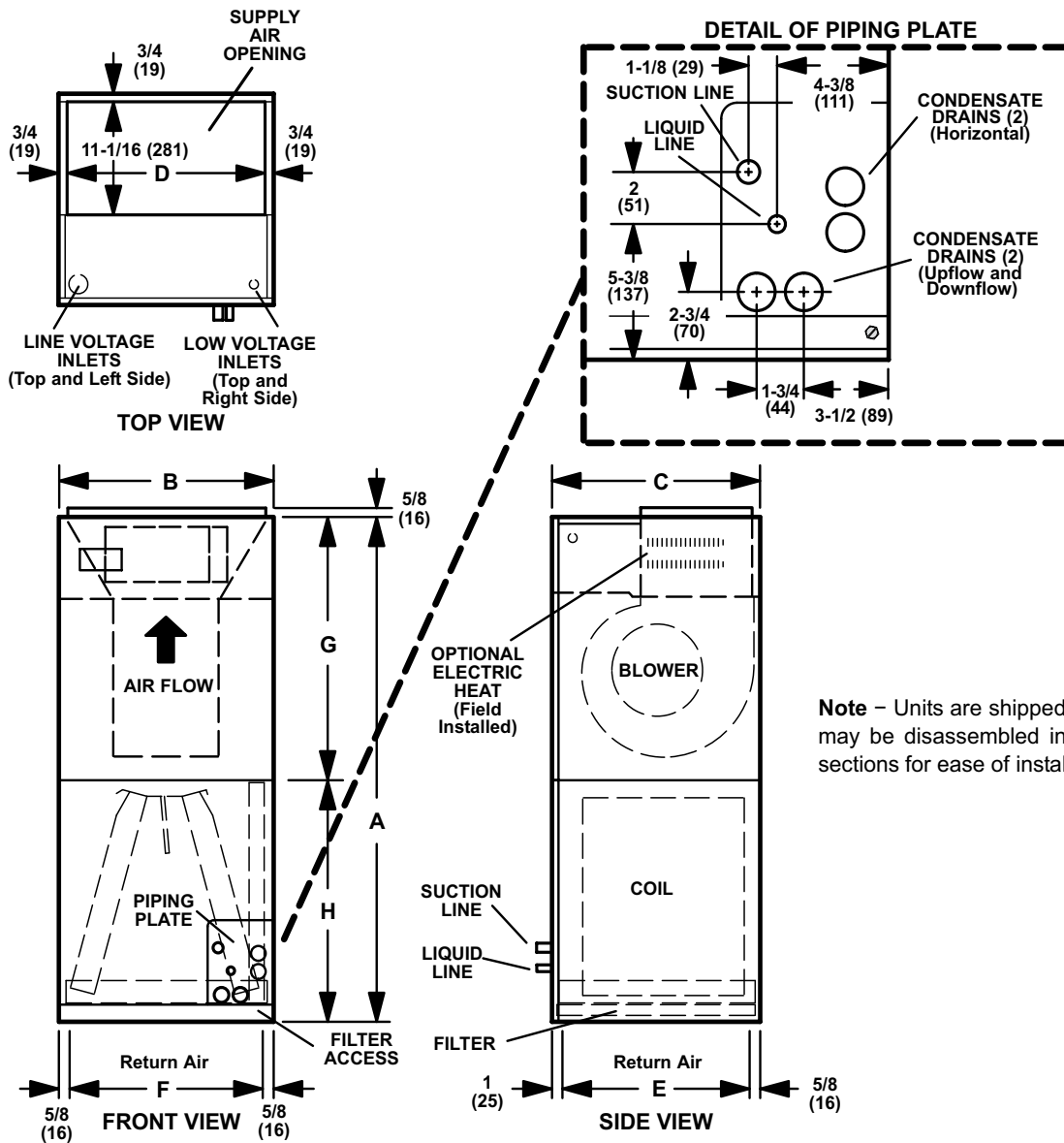

Note – Units are shipped in one piece but may be disassembled into two separate sections for ease of installation.

Dimensions	018, 024		030, 036		042, 048		060	
	in.	mm	in.	mm	in.	mm	in.	mm
A	49-1/4	1251	51	1295	58-1/2	1486	62-1/2	1588
B	21-1/4	540	21-1/4	540	21-1/4	540	21-1/4	540
C	20-5/8	524	22-5/8	575	24-5/8	625	24-5/8	625
D	19-3/4	502	19-3/4	502	19-3/4	502	19-3/4	502
E	19	483	21	533	23	584	23	584
F	20	508	20	508	20	508	20	508
G	24-5/8	625	26-3/8	670	27-7/8	708	27-7/8	708
H	24-5/8	625	24-5/8	625	30-5/8	778	34-5/8	879

NOTE - Optional Downflow Conversion Kit Required

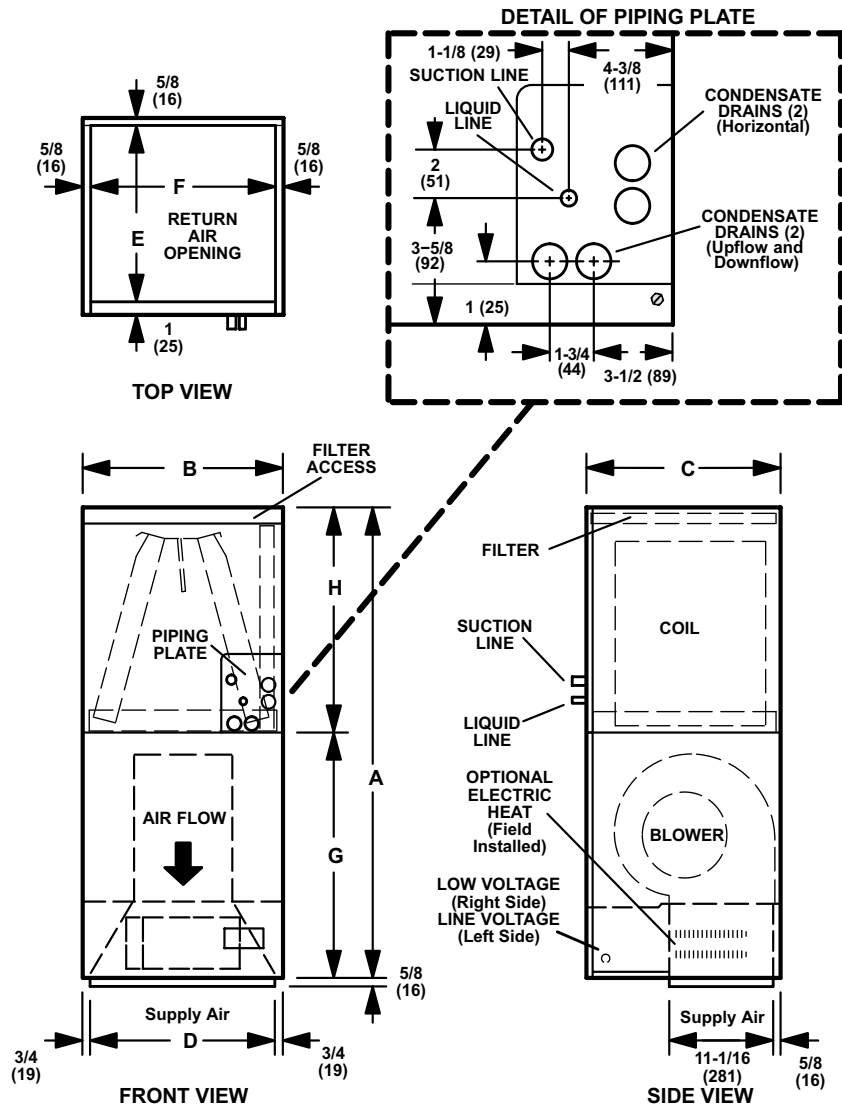

Note – Units are shipped in one piece but may be disassembled into two separate sections for ease of installation.

Dimensions	018, 024		030, 036		042, 048		060	
	in.	mm	in.	mm	in.	mm	in.	mm
A	49-1/4	1251	51	1295	58-1/2	1486	62-1/2	1588
B	21-1/4	540	21-1/4	540	21-1/4	540	21-1/4	540
C	20-5/8	524	22-5/8	575	24-5/8	625	24-5/8	625
D	19-3/4	502	19-3/4	502	19-3/4	502	19-3/4	502
E	19	483	21	533	23	584	23	584
F	20	508	20	508	20	508	20	508
G	24-5/8	625	26-3/8	670	27-7/8	708	27-7/8	708
H	24-5/8	625	24-5/8	625	30-5/8	778	34-5/8	879

DIMENSIONS

UNIT - HORIZONTAL RIGHT-HAND POSITION

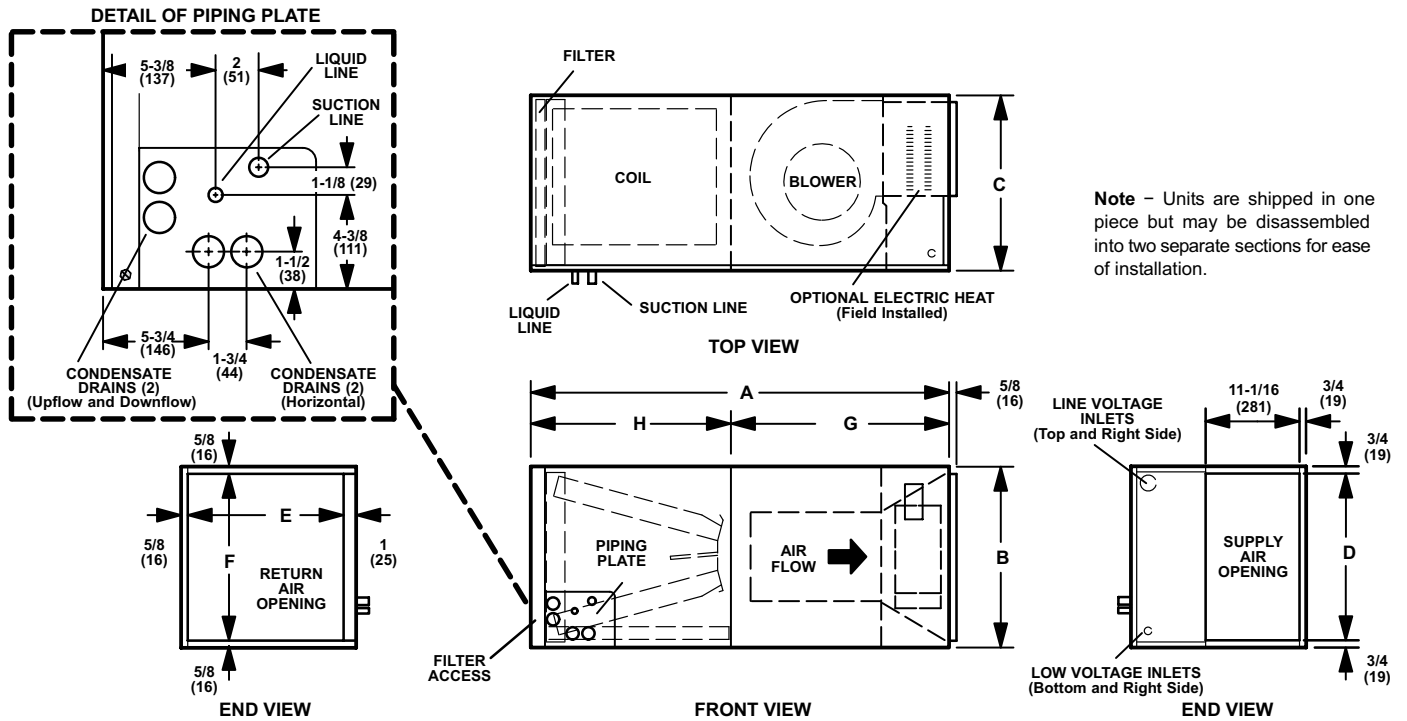

DIMENSIONS - UNIT

HORIZONTAL LEFT-HAND POSITION

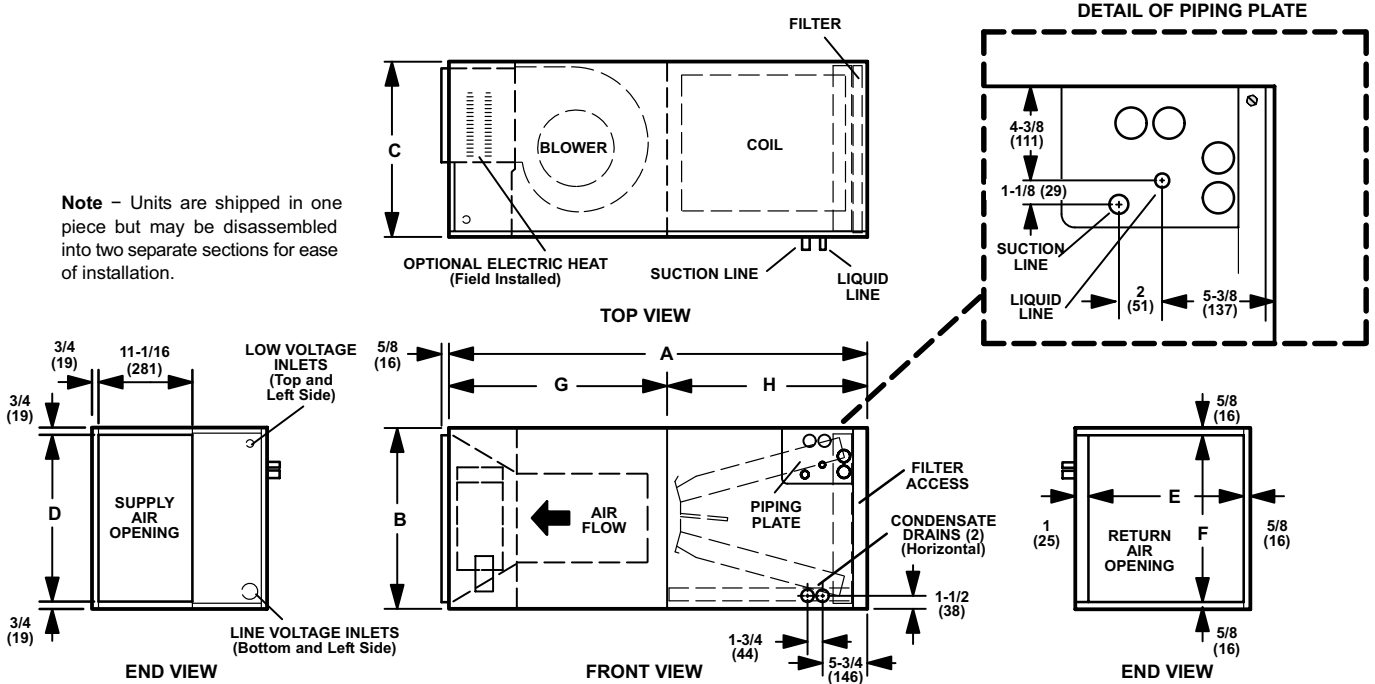

Dimensions	018, 024		030, 036		042, 048		060	
	in.	mm	in.	mm	in.	mm	in.	mm
A	49-1/4	1251	51	1295	58-1/2	1486	62-1/2	1588
B	21-1/4	540	21-1/4	540	21-1/4	540	21-1/4	540
C	20-5/8	524	22-5/8	575	24-5/8	625	24-5/8	625
D	19-3/4	502	19-3/4	502	19-3/4	502	19-3/4	502
E	19	483	21	533	23	584	23	584
F	20	508	20	508	20	508	20	508
G	24-5/8	625	26-3/8	670	27-7/8	708	27-7/8	708
H	24-5/8	625	24-5/8	625	30-5/8	778	34-5/8	879

DOWNFLOW COMBUSTIBLE FLOORING BASE

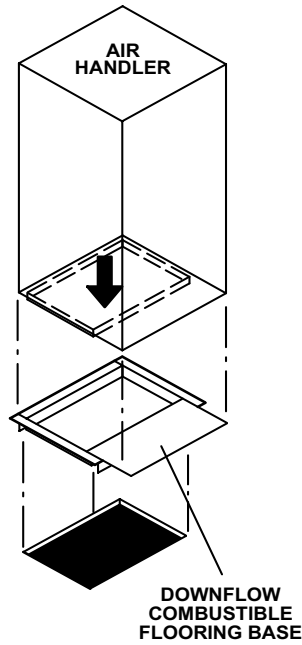

DOWNFLOW COMBUSTIBLE FLOORING BASE DETAIL

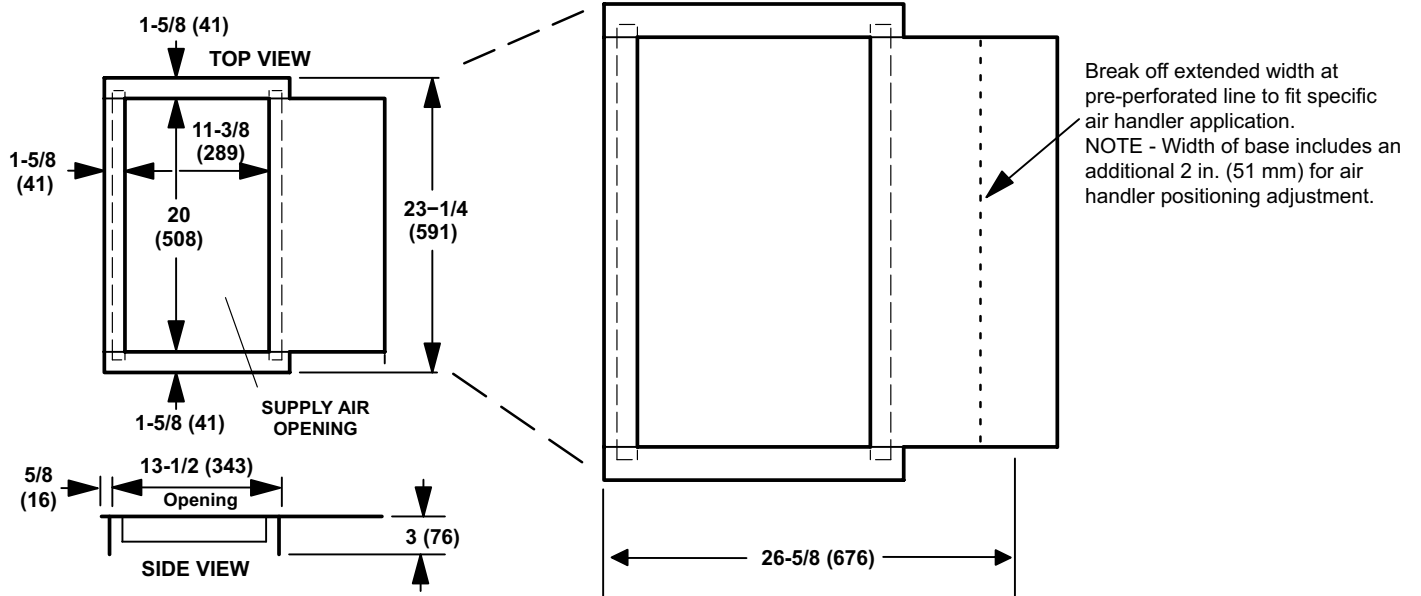

HORIZONTAL SUPPORT FRAME KIT

Suspension Rods (Not furnished)

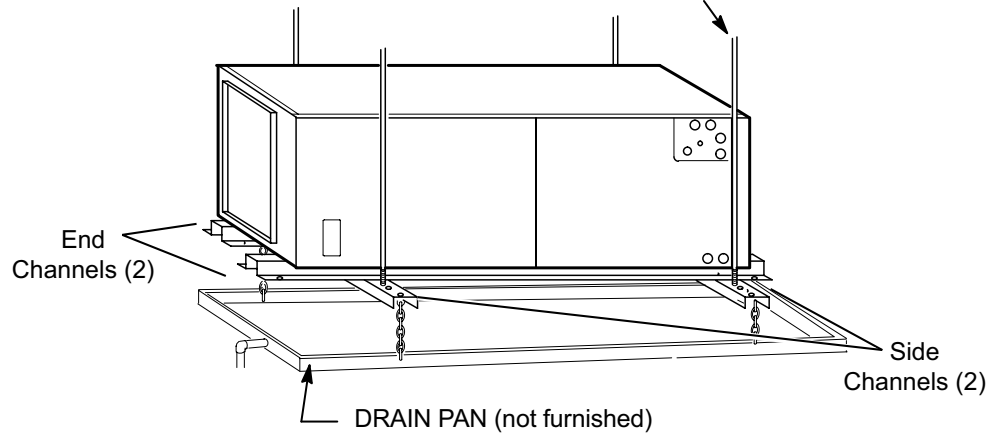

Includes (2) 1 x 1-1/2 x 32-5/8 in. side channels and (2) 1 x 3 x 53-7/8 in. end channels.

SIDE RETURN UNIT STAND

(Upflow Only)

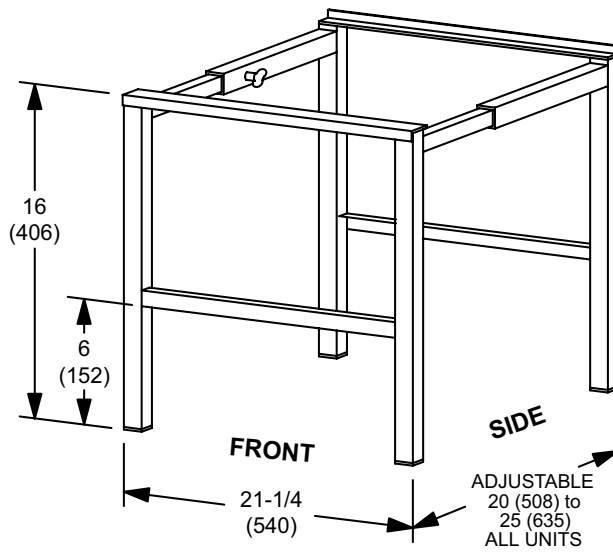



Contact us at 1-800-448-5872

NOTE - Due to our ongoing commitment to quality, Specifications, Ratings and Dimensions subject to change without notice and without incurring liability. Improper installation, adjustment, alteration, service or maintenance can cause property damage or personal injury. Installation and service must be performed by a qualified installer and servicing agency.

©2024 Allied Air Enterprises