

SUBMITTAL SHEET

JOB NAME	ITEM TAG
JOB LOCATION	PART NUMBER
CONTRACTOR	DATE
ENGINEER APPROVAL	DATE

FULL-PORT PRESS BALL VALVE

P-200 LegendPress™

Press-to-connect end connections are designed for installation onto ASTM B88 types K, L and M hard-drawn copper tubing. See insertion depth chart below.

Deeper tubing sockets and dual O-rings at each press connection, provide extra stability during the pressing process as well as enhanced sealing.

Compatible with commercially-available VUS profile jaws.

Oversized lever handle with pre-drilled tag hole is ideal for commercial applications.

Sizes 1-2" to 1-1/4" Press x Press are also available with assembled extended T-handles and color coded identification discs imprinted with the following: Red; "HOT", Blue; "COLD" and Purple; "RECLAIMED WATER" for insulated tubing applications.

Available in sizes; 1/2" to 4" in the Press x Press configuration, 1/2" to 2" in the MIP x Press configurations and 1/2" to 1-1/4" in the MIP Union x Press configuration.

Working Pressure, Non Shock (PSI)

Cold working pressure (CWP):	1/2" and 3/4": 600 p.s.i.
	1" and 1-1/4": 500 p.s.i.
	1-1/2" and 2": 400 p.s.i.

Saturated steam (WSP): Not suitable for steam service

Maximum service temp:

230°F

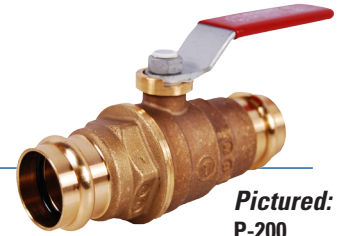

**Pictured:
P-200**



**Pictured:
P-200 with T-Handle**

- Valve construction conforms to MSS SP-110; press-type end connections are currently excluded from this standard.
- Threaded end connections conform to ANSI / ASME B1.20.1
- Manufactured in an ISO accredited facility.

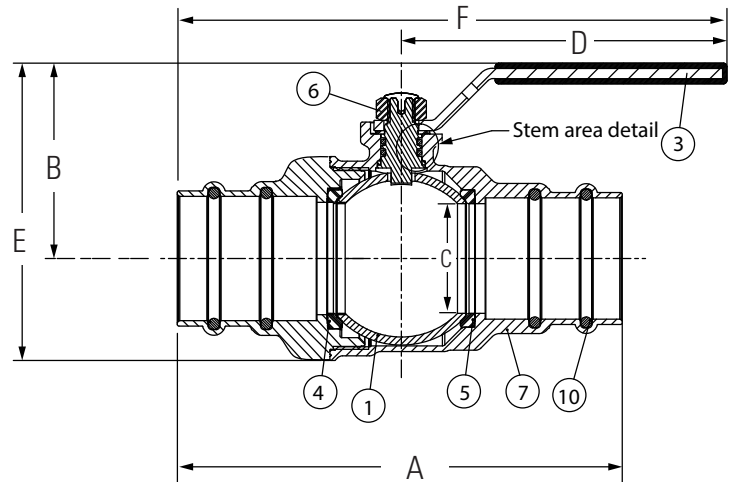

**Pictured:
P-200 LegendPress™
Cut-away view**

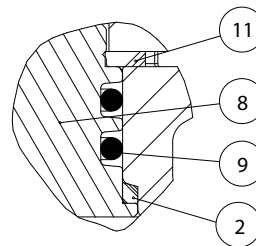

**Pictured:
P-200 LegendPress™
Stem area detail**

MATERIAL SPECIFICATION

PART	MATERIAL	SPECIFICATION
1 Ball	Chrome plated forged brass	ASTM B124 UNS C37700
2 Thrust washer	TFM PTFE	Dyneon*
3 Handle	Dacromet coated steel	ASTM A510 UNS G10060
4 End adapter	Forged brass	ASTM B124 UNS C37700
5 Seats (2)	TFM PTFE	Dyneon*
6 Handle nut	Dacromet coated steel with resin lock	ASTM A510 UNS G10060
7 Body	Forged brass	ASTM B124 UNS C37700
8 Stem	Chrome plated forged brass	ASTM B124 UNS C37700
9 Stem O-rings (2)	Fluoroelastomer	Viton**
10 Socket O-rings (4) [2 per socket]	EPDM	Commerical grade
11 Anti-friction washer	TFM PTFE	Dyneon*

*Dyneon TFM is a registered trademark of the 3M Company.

**Viton is a registered trademark of DuPont.

DIMENSIONS PRESS x PRESS

Size	A	B	C	D	E	F
1/2"	3.90	1.43	0.59	3.04	2.05	5.00
3/4"	4.51	1.90	0.79	3.74	2.68	6.00
1"	4.77	2.06	1.00	3.74	3.01	6.13
1-1/4"	5.08	2.24	1.26	3.74	3.40	6.28
1-1/2"	5.83	2.77	1.58	5.38	4.15	8.30
2"	7.33	3.08	2.00	5.38	4.76	9.15

LegendPress™ Tubing Insertion Depth

Nominal Tubing Size:	1/2"	3/4"	1"	1-1/4"	1-1/2"	2"
Insertion Depth: In.	1-3/8"	1-9/16"	1-9/16"	1-9/16"	1-3/4"	2-3/16"
MM	35	40	40	40	45	55

See P-200 Large Diameter submittal for 2-1/2" to 4" sizes

¹ Note: These configurations are also available with assembled extended T-Handle. The T-Handle's width is 3.06" The overall height from the stem base to the top of the handle is 1.76" and the diameter is 1.28". At least 1.25" of insulation can be applied onto the valve's body and around the T-Handle area without affecting the operation of the valve.

SUBMITTAL SHEET (Page 2)

FULL-PORT PRESS-TO-CONNECT BALL VALVE

P-200 LegendPress™ Transition Connections

DIMENSIONS						
Size	A	B	C	D	E	F
1/2" MIP x P	4.38	1.43	0.59	3.04	2.09	5.47
3/4" MIP x P	3.99	1.90	0.79	3.74	2.70	5.48
1" MIP x P	4.31	2.06	1.00	3.74	3.03	5.67
1-1/4" MIP x P	4.83	2.24	1.26	3.74	3.41	6.04
1-1/2" MIP x P	5.49	2.76	1.58	5.38	4.19	7.76
2" MIP x P	6.28	3.07	2.00	5.38	4.80	8.10
1/2" FIP x P	3.05	1.43	0.59	3.04	2.07	4.15
3/4" FIP x P	3.48	1.90	0.79	3.74	2.71	4.97
1" FIP x P	3.88	2.06	1.00	3.74	3.03	5.24
1-1/4" FIP x P	4.23	2.24	1.26	3.74	3.41	5.43
1-1/2" FIP x P	5.01	2.76	1.58	5.38	4.19	7.28
2" FIP x P	5.73	3.07	2.00	5.38	4.80	7.56
1/2" MIP union x P	4.38	1.43	0.59	3.04	2.09	5.47
3/4" MIP union x P	4.99	1.90	0.79	3.74	2.73	6.47
1" MIP union x P	5.29	2.06	1.00	3.74	3.07	6.65
1-1/4" MIP union x P	5.88	2.24	1.26	3.74	3.40	7.08

MATERIAL SPECIFICATION		
PART	MATERIAL	SPECIFICATION
1 Ball	Chrome plated forged brass	ASTM B124 UNS C37700
2 Thrust washer	TFM PTFE	Dyneon*
3 Handle	Dacromet coated steel	ASTM A510 UNS G10060
4 End adapter	Forged brass	ASTM B124 UNS C37700
5 Seats (2)	TFM PTFE	Dyneon*
6 Handle nut	Dacromet coated steel with resin lock	ASTM A510 UNS G10060
7 Body	Forged brass	ASTM B124 UNS C37700
8 Stem	Chrome plated forged brass	ASTM B124 UNS C37700
9 Stem O-rings (2)	Fluoroelastomer	Viton**
10 Socket O-rings (4) [2 per socket]	EPDM	Commercial grade
11 Anti-friction washer	TFM PTFE	Dyneon*

UNION END CONNECTION ONLY		
PART	MATERIAL	SPECIFICATION
12 Tailpiece seal	TFM PTFE	Dyneon*
13 Union nut	Forged brass	ASTM B124 UNS C37700
14 Union tailpiece	Forged brass	ASTM B124 UNS C37700

*Dyneon TFM is a registered trademark of the 3M Company.
**Viton is a registered trademark of DuPont.

LegendPress™ Tubing Insertion Depth						
Nominal Tubing Size:	1/2"	3/4"	1"	1-1/4"	1-1/2"	2"
Insertion Depth: In.	1-3/8"	1-9/16"	1-9/16"	1-9/16"	1-3/4"	2-3/16"
MM	35	40	40	40	45	55

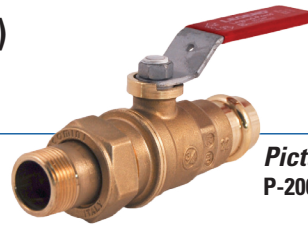
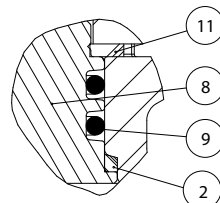

Pictured:
P-200 MIP Union x Press

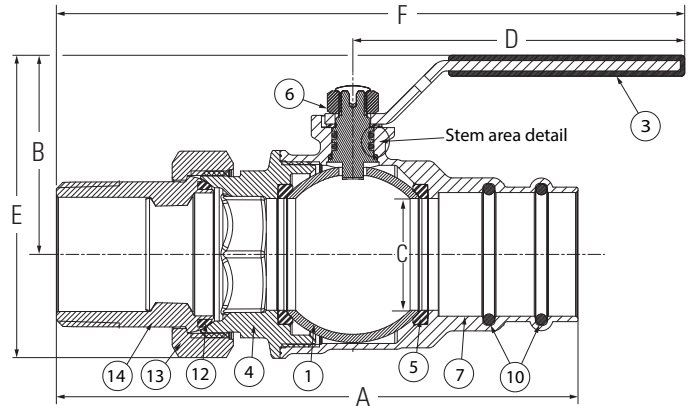

LegendPress™ MIP Union x Press
Cut-away view

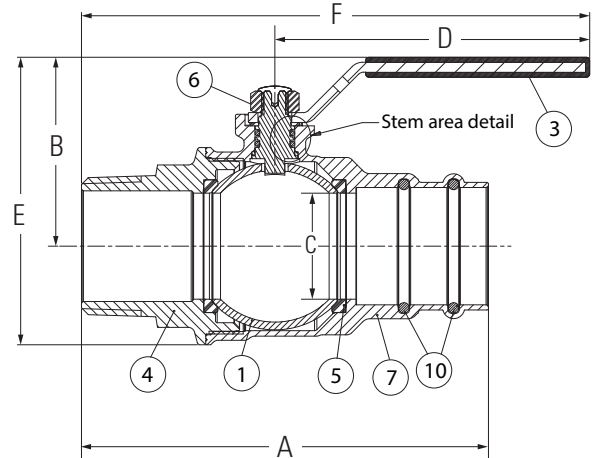

LegendPress™ MIP x Press
Cut-away view

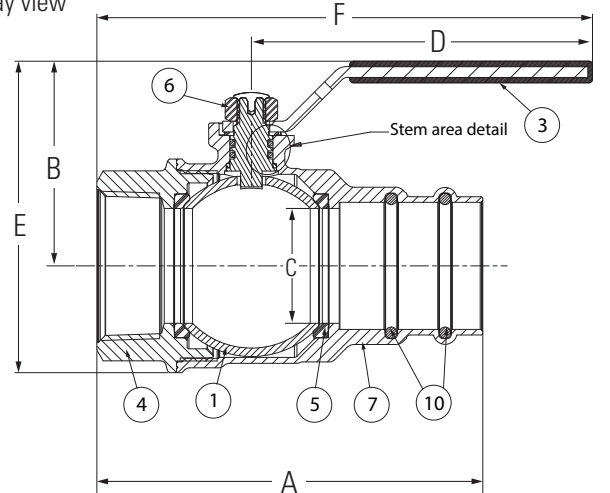

LegendPress™ FIP x Press
Cut-away view

Pictured:
P-200 LegendPress™
Stem area detail