



# LANCASTER

---

# HYDRO-FORCE™

4" Submersible Motors

Single Phase, 230 Volt, 60 Hertz

- 2-Wire Motors
- 3-Wire Motors
- Control Boxes for use with 3-Wire Motors

---

**TECHNICAL BULLETIN**

# INDEX

|  |              |
|--|--------------|
| <b>Technical Features &amp; Operating Limits .....</b>       | <b>3</b>     |
| <b>Catalog Numbers, Dimensions, Weight .....</b>             | <b>4</b>     |
| <b>Operating Data.....</b>                                   | <b>5</b>     |
| <b>Motor Tests: 2-Wire &amp; 3-Wire Motors</b>               |              |
| <b>Insulation Resistance (Ground) Test .....</b>             | <b>6</b>     |
| <b>Winding Resistance Test .....</b>                         | <b>7</b>     |
| <b>Cable Tests:</b>  |              |
| <b>Checking Cable and Splice.....</b>                        | <b>8</b>     |
| <b>Identify Cable Leads (when color is unknown).....</b>     | <b>9</b>     |
| <b>Cable Selection.....</b>                                  | <b>9</b>     |
| <b>3-Wire Control Boxes Description “How it works” .....</b> | <b>10</b>    |
| <b>3-Wire Control Box Troubleshooting:</b>                   |              |
| <b>with POWER ON.....</b>                                    | <b>11</b>    |
| <b>with POWER OFF (component diagnostic testing) .....</b>   | <b>12-13</b> |

## **LANCASTER HYDRO-FORCE™**

**4" ENCAPSULATED SUBMERSIBLE MOTORS**

**SINGLE PHASE 230 VOLT 60 HERTZ**

**TWO-WIRE ½ - 1½ HP & THREE-WIRE ½ - 1 HP**

### **TECHNICAL FEATURES**

#### **Two-Wire Design**

- Split-phase induction run (IR) design with built-in electronic starter connected in series to a high resistance auxiliary start winding – no capacitor required – electronic starter controls disengagement of start winding as a function of starting time and starting voltage.

#### **Three-Wire Design**

- Capacitor-start induction run (CSIR) design – control box required –
  - Control box quick-disconnect design disconnects control box components from the electrical system when the lid is removed – will retrofit F.E. Q-D control boxes of same HP and voltage.
  - Control box components include a 230V voltage relay for easy installation, two ground terminals, cable terminals up to AWG 8, and a start capacitor for higher starting torque.
  - Control box painted steel enclosure with multiple knockouts is rated NEMA 3R for indoor or outdoor installation.

#### **Two-Wire and Three-Wire Designs**

- Stator filled with special epoxy resin and hermetically sealed for a better insulation of the winding and a greater heat exchange.
- Rotor and thrust bearings lubricated by water mixed with Propylene Glycol.
- Built-in check valve for restoring of cooling liquid (well water) as needed.
- Built-in lightning arrestors providing surge protection.
- Built-in automatic reset overload providing thermal (overheat) protection caused by high amperage and/or inadequate motor cooling.
- AISI 304 Stainless Steel motor frame shell, stator ends and stator liner, hermetically sealed for maximum corrosion resistance.
- AISI 303 Stainless Steel splined shaft end.
- Cationic epoxy electrocoated G20 cast iron top and bottom end brackets.
- AISI 304 Stainless Steel top and bottom end bracket covers.
- Shaft sealing system using labyrinth seal, sand slinger and lip seal.
- Pressure equalizing diaphragm.
- 4" NEMA flange.
- M8 threaded mounting studs.
- Removable plug-in lead cable.
- Degree of protection: IP68.
- Insulation: Class B.
- Time Rating: Continuous Duty.
- UL recognized component.
- UL classified water quality system component in accordance with ANSI/NSF 61 (health effects) and 372 (lead content).

### **OPERATING LIMITS**

- Water temperature: max. 95°F (35°C).
- Maximum starts per hour: 30.
- Minimum flow rate speed for motor cooling in water up to 95°F: 0.26 ft/s (0.08 m/s).
- Voltage tolerance: two-wire design +/-10%, three-wire design +6%/-10%.
- Maximum submergence depth: 492 ft (150m).
- Mounting position: vertical/horizontal.
- NEMA service factors (S.F.) for 60 Hz pump motors.
- Axial Thrust Load: 300 Lb (1500 N) up to 1 HP, 650 Lb (3000 N) for the 1½ HP.

**LANCASTER HYDRO-FORCE™**  
**4" ENCAPSULATED SUBMERSIBLE MOTORS**  
**SINGLE-PHASE 230 VOLT**

|               | MOTOR CATALOG NUMBER | MOTOR TYPE   | CONTROL BOX  | HP   | SF  | LENGTH IN. | WEIGHT LB. |
|---------------|----------------------|--------------|--------------|------|-----|------------|------------|
| <b>2-WIRE</b> | 6-2LS312-59          | 4WP 050 M 2W | NOT REQUIRED | 0.5  | 1.6 | 10.69      | 19.6       |
|               | 6-2LS412-59          | 4WP 075 M 2W | NOT REQUIRED | 0.75 | 1.5 | 11.69      | 22.0       |
|               | 6-2LS512-59          | 4WP 100 M 2W | NOT REQUIRED | 1    | 1.4 | 12.44      | 24.1       |
|               | 6-2LS612-59          | 4WP 150 M 2W | NOT REQUIRED | 1.5  | 1.3 | 15.25      | 29.7       |
| <b>3-WIRE</b> | 6-3LS312-59          | 4WP 050 M    | 6-3LS312-49  | 0.5  | 1.6 | 10.25      | 19.5       |
|               | 6-3LS412-59          | 4WP 075 M    | 6-3LS412-49  | 0.75 | 1.5 | 10.50      | 20.2       |
|               | 6-3LS512-59          | 4WP 100 M    | 6-3LS512-49  | 1    | 1.4 | 12.12      | 23.9       |

**LANCASTER HYDRO-FORCE™**  
**QUICK-DISCONNECT CONTROL BOXES**  
**SINGLE-PHASE 230 VOLT**

|               | CONTROL BOX CATALOG NUMBER | CONTROL BOX CODE | CONTROL BOX DESCRIPTION TYPE | HP   | ENCLOSURE DIMENSIONS W x D x H INCHES | WEIGHT LB. |
|---------------|----------------------------|------------------|------------------------------|------|---------------------------------------|------------|
| <b>3-WIRE</b> | 6-3LS312-49                | 20201010         | CSIR-4 050M                  | 0.5  | 4.8 x 2.9 x 8.4                       | 3          |
|               | 6-3LS412-49                | 20201020         | CSIR-4 075M                  | 0.75 |                                       |            |
|               | 6-3LS512-49                | 20201040         | CSIR-4 100M                  | 1    |                                       |            |

3.740" MAX  
DIAMETER



LENGTH

W  
D



H

# LANCASTER HYDRO-FORCE™ 4" SUBMERSIBLE MOTORS

## SINGLE PHASE, 60 HZ, 3450 RPM

### OPERATING DATA

#### 2-WIRE MOTORS

| CATALOG NUMBER | TYPE         | RATING |      |       |    |      | MAX. LOAD (S.F. LOAD) AMPS | MAIN WINDING RESISTANCE OHMS (1) | INRUSH START/ LOCKED ROTOR AMPS | CIRCUIT BREAKER (2) |
|----------------|--------------|--------|------|-------|----|------|----------------------------|----------------------------------|---------------------------------|---------------------|
|                |              | HP     | KW   | VOLTS | HZ | S.F. |                            |                                  |                                 |                     |
| 6-2LS312-59    | 4WP 050 M 2W | 1/2    | 0.37 | 230   | 60 | 1.6  | 6.4                        | 4.6-5.2                          | 31                              | 15                  |
| 6-2LS412-59    | 4WP 075 M 2W | 3/4    | 0.55 | 230   | 60 | 1.5  | 9.3                        | 3.5-3.9                          | 39                              | 20                  |
| 6-2LS512-59    | 4WP 100 M 2W | 1      | 0.75 | 230   | 60 | 1.4  | 12.0                       | 2.3-2.6                          | 50                              | 25                  |
| 6-2LS612-59    | 4WP 150 M 2W | 1-1/2  | 1.1  | 230   | 60 | 1.3  | 15.4                       | 1.7-1.9                          | 71                              | 30                  |

- (1) Acceptable Line-to-Line resistance range as measured between the two motor leads (values above do not include resistance of the drop cable).  
 (2) Circuit breaker sizes are typical submersible installations.

#### 3-WIRE MOTORS

| CATALOG NUMBER | TYPE      | RATING |      |       |    |      | MAX. LOAD (S.F. LOAD) AMPS (1) |      |   | WINDING RESISTANCE MOTOR ONLY OHMS (2) |           | INRUSH START/ LOCKED ROTOR AMPS | CIRCUIT BREAKER (3) |
|----------------|-----------|--------|------|-------|----|------|--------------------------------|------|---|--|-----------|---------------------------------|---------------------|
|                |           | HP     | KW   | VOLTS | HZ | S.F. | Y                              | B    | R | MAIN                                   | START     |                                 |                     |
| 6-3LS312-59    | 4WP 050 M | 1/2    | 0.37 | 230   | 60 | 1.6  | 6.4                            | 6.4  | 0 | 4.8-6.0                                | 16.5-20.9 | 22                              | 15                  |
| 6-3LS412-59    | 4WP 075 M | 3/4    | 0.55 | 230   | 60 | 1.5  | 9.3                            | 9.3  | 0 | 3.3-4.1                                | 11.2-14.2 | 32                              | 20                  |
| 6-3LS512-59    | 4WP 100 M | 1      | 0.75 | 230   | 60 | 1.4  | 12.0                           | 12.0 | 0 | 2.1-2.7                                | 6.8-8.6   | 40                              | 25                  |

- (1) Y = Yellow lead - line amps  
 B = Black lead - main winding amps  
 R = Red lead - start (a.k.a. auxiliary) winding amps  
 (2) Main winding - yellow to black - values as measured between the two motor leads (values do not include resistance of the drop cable).  
 Start winding - yellow to red - values as measured between the two motor leads (values do not include resistance of the drop cable).  
 (3) Circuit breaker sizes are typical submersible installations.

#### CONTROL BOXES for 3-WIRE MOTORS

| CATALOG NUMBER | DESCRIPTION |             | HP  | KW   | VOLTS | HZ | START CAPACITOR (1) |       | START RELAY (2) POTENTIAL (VOLTAGE) TYPE SUPPLIER CODE |
|----------------|-------------|-------------|-----|------|-------|----|---------------------|-------|--|
|                | CODE        | TYPE        |     |      |       |    | MFD                 | VOLTS |  |
| 6-3LS312-49    | 20201010    | CSIR-4 050M | 1/2 | 0.37 | 230   | 60 | 53-64               | 330   | RVA2ALKL   |
| 6-3LS412-49    | 20201020    | CSIR-4 075M | 3/4 | 0.55 | 230   | 60 | 88-106              | 280   |  |
| 6-3LS512-49    | 20201040    | CSIR-4 100M | 1   | 0.75 | 230   | 60 | 100-125             | 320   |  |

- (1) Start capacitors are supplied with a 15,000-18,000 ohm, two watt bleed-resistor securely attached and soldered to their terminals.  
 (2) Start relay is designed to operate ONLY on 230-volt systems. For 208-volt systems or where line voltage is between 200 volts and 210 volts, a low voltage relay is required.

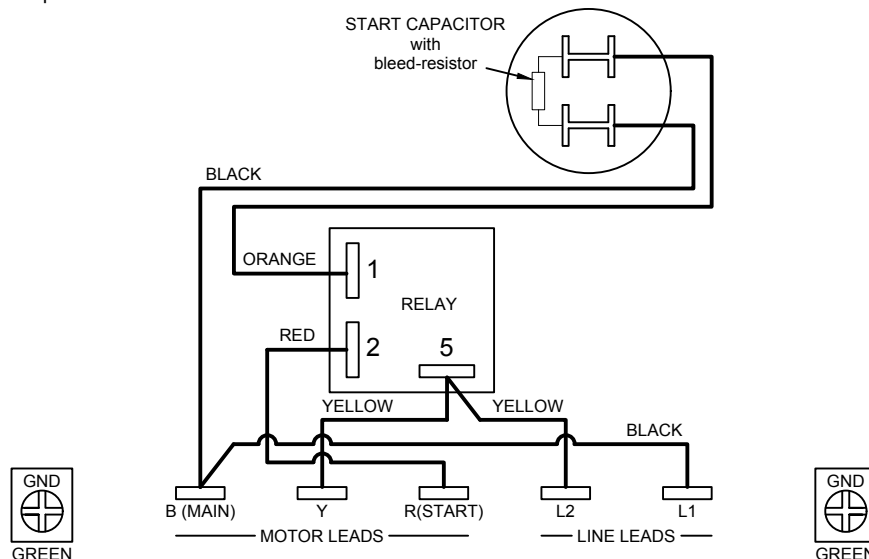

# LANCASTER HYDRO-FORCE™

## 2-Wire & 3-Wire

### Motor Tests

#### Insulation Resistance (Ground) Test:

#### Procedure-

- 1) **WARNING! MAKE SURE POWER IS TURNED OFF!** Open (turn off) master breaker and disconnect all motor leads from control box (3-wire motor installation) or pressure switch (2-wire motor installation).
- 2) Use a megohmmeter or an ohmmeter with the scale lever set to R x 100K (R x 100,000). Short the meter leads together and "zero" the ohmmeter using the meter's adjustment dial.
- 3) Connect one meter lead to any one of the motor leads and the other meter lead to ground. See diagram...

ATTACH THIS METER LEAD TO GROUND:

A) IF MOTOR IS OUT OF WATER, ATTACH THIS METER LEAD TO MOTOR FRAME.

B) IF MOTOR IS INSTALLED IN WATER, ATTACH THIS METER LEAD TO METAL WELL CASING (IF SUBMERGED), METAL DROP PIPE, MOTOR GROUND LEAD, OR AN EXTRA WIRE EXTENDING INTO THE GROUND WATER.

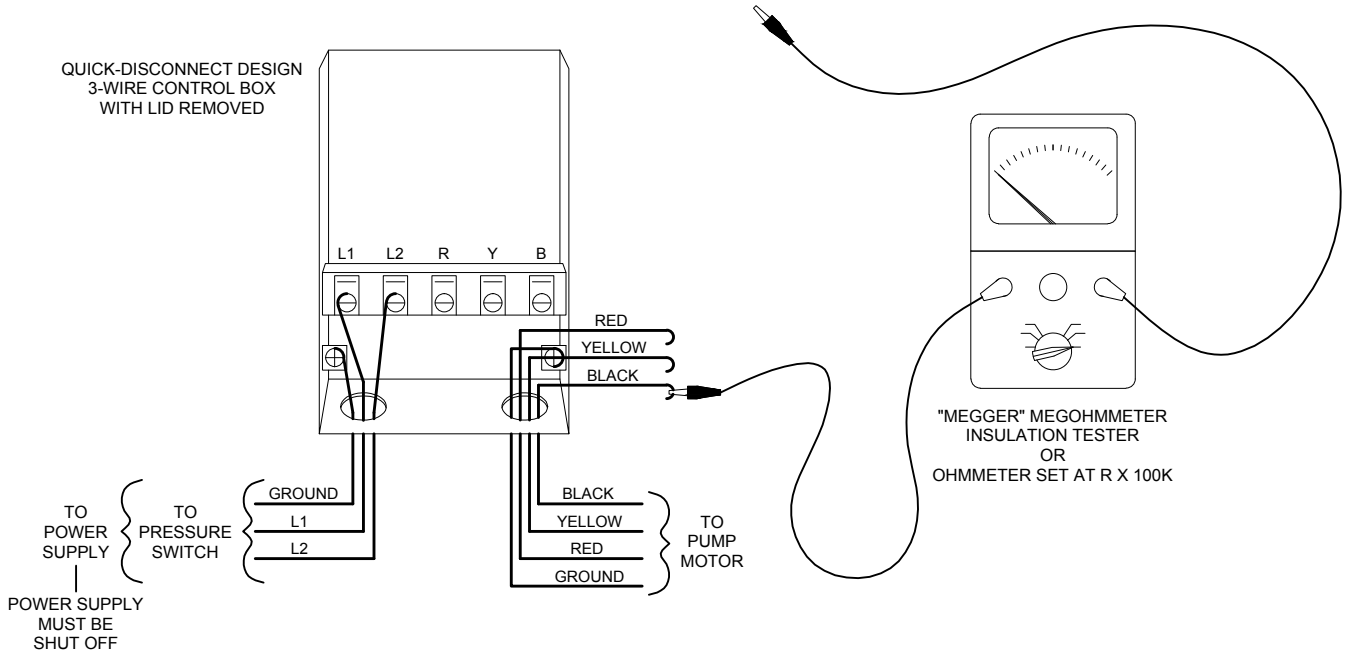

#### Test result (what it means)-

- 1) If the ohms value is normal, the motor is not grounded and the cable insulation is not damaged.
- 2) If the ohms value is below normal, either the motor windings are grounded or the cable insulation is damaged. Check the cable at the well seal as the insulation is sometimes damaged by being pinched. Refer to "Checking Cable and Splice" section of this bulletin.

NORMAL OHM AND MEGOHM VALUES (INSULATION RESISTANCE) BETWEEN ALL LEADS AND GROUND.

| CONDITION OF MOTOR AND LEADS                           | OHMS VALUE            | MEGOHMS VALUE   |
|--|-----------------------|-----------------|
| A new motor (without drop cable).                      | 200,000,000 (or more) | 200.0 (or more) |
| A used motor which can be reinstalled in well.         | 10,000,000 (or more)  | 10.0 (or more)  |
| MOTOR IN WELL. READINGS ARE FOR DROP CABLE PLUS MOTOR. |                       |                 |
| New motor.   | 2,000,000 (or more)   | 2.0 (or more)   |
| Motor in good condition.                               | 500,000 - 2,000,000   | 0.50 - 2.0      |
| Insulation damage; locate and repair.                  | Less than 500,000     | Less than 0.50  |

Insulation resistance varies very little with rating. All motors, regardless of HP, voltage and phase rating have similar values of insulation resistance. The table above is based on readings taken with a Fluke 1503 Insulation Tester using 500 VDC output test voltage.

# LANCASTER HYDRO-FORCE™

## 2-Wire & 3-Wire Motor Tests

### Winding Resistance Test:

#### Procedure-

- 1) **WARNING! MAKE SURE POWER IS TURNED OFF!** Open (turn off) master breaker and disconnect all motor leads from control box (3-wire motor installation) or pressure switch (2-wire motor installation).
- 2) Use an ohmmeter with the scale lever set to R x 1 for values under 10 ohms. For values over 10 ohms, set the scale lever to R x 10. Short the meter leads together and turn the meter's adjustment dial to "zero" the meter.
- 3) On 2-wire motors, measure the main winding resistance from line-to-line by connecting the ohmmeter between the two motor leads.  
On 3-wire motors, measure the main winding resistance (yellow to black) and the start winding resistance (yellow to red) by connecting the ohmmeter between the two motor leads described.

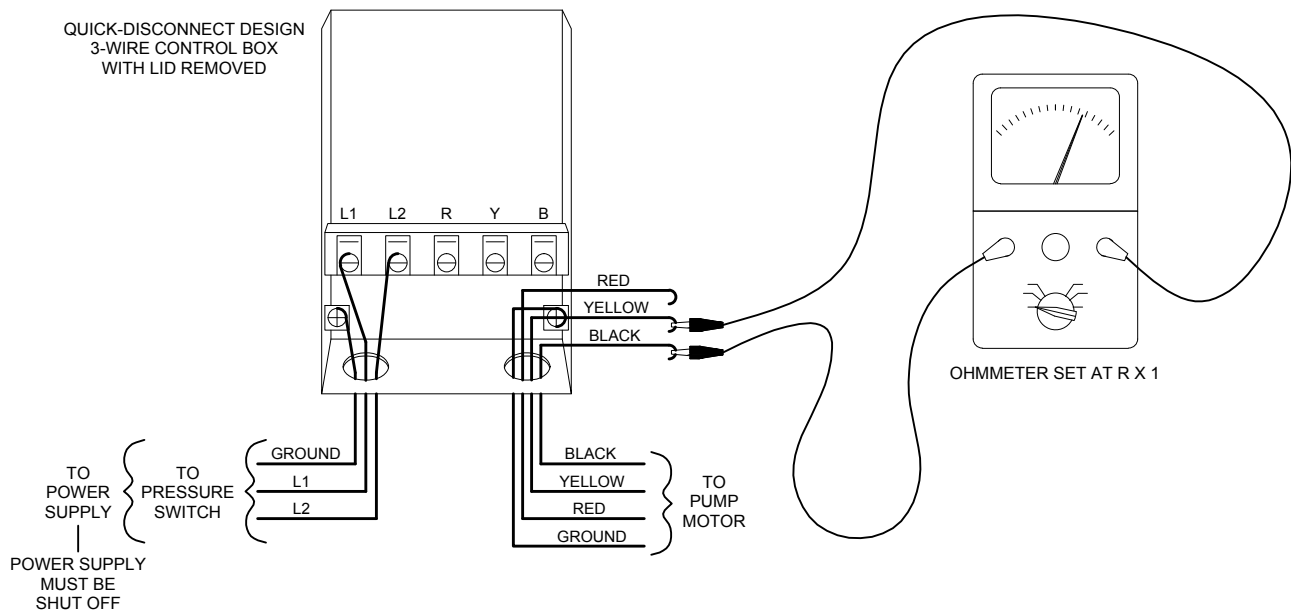

#### Test result (what it means)-

- 1) Correct readings should be equal to the winding resistance values from the charts on the OPERATING DATA PAGE for a given motor, plus the resistance of the drop cable from the following table...

|                | DC Resistance (ohms) per 100 feet of Copper Cable (two leads) at 50 °F |       |       |       |       |
|----------------|--|-------|-------|-------|-------|
| AWG Cable Size | 14   | 12    | 10    | 8     | 6     |
| Ohms           | 0.544  | 0.338 | 0.214 | 0.135 | 0.082 |

This chart shows the total resistance of copper cable from ohmmeter to motor and back (round trip). If aluminum conductor cable is used, the resistance will be higher... divide ohms from this chart by 0.61 for aluminum cable resistance.

#### 2) Conditions:

- A) If any one ohm value is less than specified, that motor winding is shorted.
- B) If any one ohm value is greater than specified, that motor winding or the cable is open, or there is a poor cable joint or connection.
- C) On 3-wire, if one ohm value is greater than specified and one ohm value less than specified, the leads are mixed. Refer to "Identify Cable Leads" section of this bulletin.

# LANCASTER HYDRO-FORCE™

## 4" Submersible Motors

### Cable Tests

#### Checking Cable and Splice:

##### Procedure-

- 1) Submerge cable and splice in a steel barrel of water with both ends out of water.
- 2) Use an ohmmeter with the scale lever set to R x 100K (R x 100,000).  
Short the meter leads together and "zero" the ohmmeter using the meter's adjustment dial.
- 3) Connect one meter lead to the steel barrel (ground) and the other meter lead to each cable lead individually. See diagram...

IF THE BARREL IS PLASTIC, ATTACH THIS METER LEAD TO THE BARE END OF AN ADDITIONAL WIRE WITH THE OPPOSITE BARE END SUBMERGED IN THE WATER.

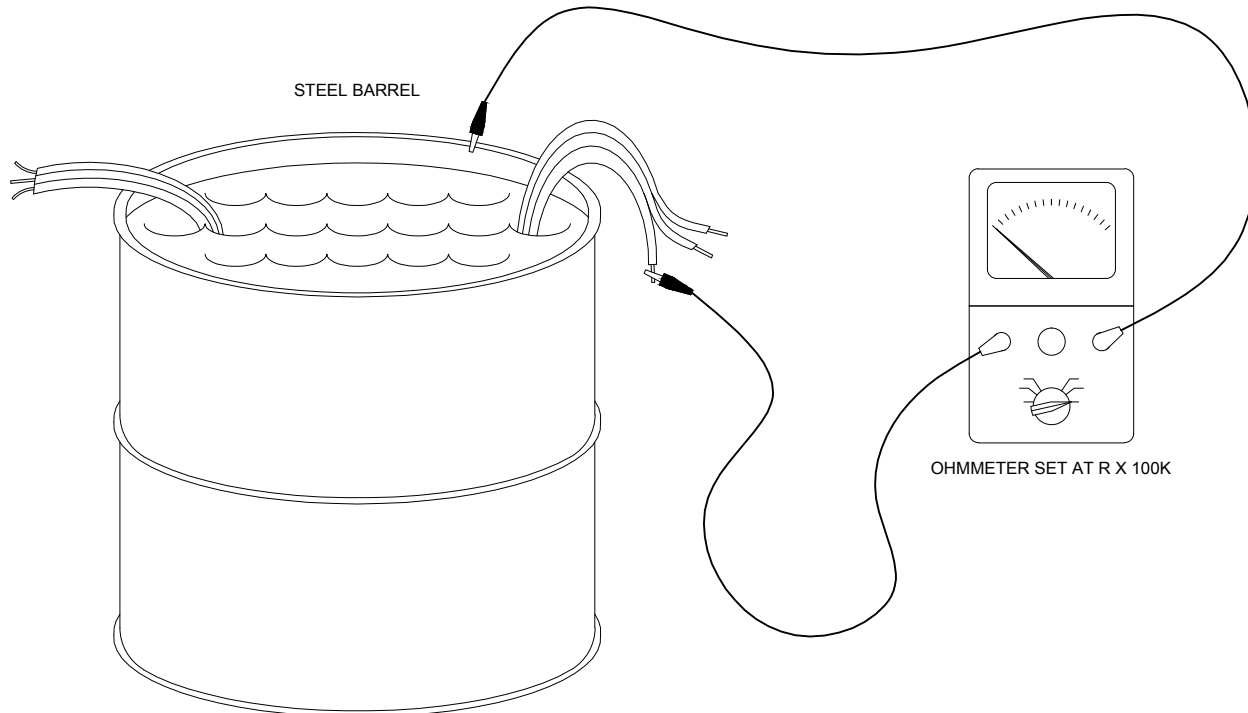

- 4) If the ohmmeter reading drops towards zero (0) ohms on any of the cable leads, pull the splice up out of the water. If the ohmmeter reading increases towards infinity ( $\infty$ ) the leak is in the splice.
- 5) If the leak is not in the splice, pull the cable out of the water slowly until the ohmmeter reading increases towards infinity ( $\infty$ ). When the ohms value increases, the leak is at that point in the cable.
- 6) If the cable or splice is bad, it should be repaired or replaced.



# LANCASTER HYDRO-FORCE™

## 4" Submersible Motors

### Cable Tests

Identify Cable Leads (when color is unknown):

For 3-wire single phase motor installations, if the colors on the individual drop cables cannot be determined and the leads cannot be positively identified, follow this procedure-

- 1) Disconnect all three drop cables from the control box. For temporary identification, tag each cable (1, 2, 3).
- 2) Using an ohmmeter, measure and record the resistance between the following cable combinations:

Cable 1 to Cable 2 \_\_\_\_\_  
 Cable 1 to Cable 3 \_\_\_\_\_  
 Cable 2 to Cable 3 \_\_\_\_\_

Note: The actual ohms values are not important. This method works regardless of the actual ohm values; what matters is which reading is highest, intermediate and lowest.

Find the highest resistance reading.

The lead not used in the highest resistance reading is the yellow lead.

Use the yellow lead and each of the other two leads to get two readings:

Highest is the red lead.

Lowest is the black lead.

# LANCASTER HYDRO-FORCE™

## 4" Submersible Motors - Single Phase, 60 Hz

### Cable Selection

### Two or Three Wire Cable - With Ground

Maximum Cable Length in Feet (Service Entrance to Motor)

| Motor Rating |     | AWG Copper Wire Size |     |      |      |      |
|--------------|-----|----------------------|-----|------|------|------|
| Volts        | HP  | 14                   | 12  | 10   | 8    | 6    |
| 230          | 1/2 | 400                  | 650 | 1020 | 1610 | 2510 |
|              | 3/4 | 300                  | 480 | 760  | 1200 | 1870 |
|              | 1   | 250                  | 400 | 630  | 990  | 1540 |
|              | 1.5 | 190                  | 310 | 480  | 770  | 1200 |

Select drop cable designed for use in water. The insulation on the conductor should be THW or equivalent.

Chart based on copper wire. Cable lengths allow for a 5% voltage drop running at max amps.

Single phase control boxes without line contactors (Quick-Disconnect design up to 1 HP) can be connected at any point in the cable run. Single phase control boxes with line contactors should be connected within the first 25% of the total maximum allowable.

Lengths meet the U.S. National Electrical Code ampacity for either 60°C or 75°C cable, individual insulated conductors or jacketed. Flat molded cable is to be considered jacketed.

# LANCASTER HYDRO-FORCE™

## 3-Wire Control Boxes

Single-phase three-wire submersible motors require the use of control boxes. Control boxes through 1 hp offer:

- Capacitor-start induction run (CSIR) design - contain a starting capacitor and a starting relay.
- Quick-disconnect design - disconnects the control box starting capacitor and starting relay from the electrical system when the lid is removed.
- Cable terminals accepting up to #8 AWG copper wire.
- Painted steel enclosure with multiple knockouts - rated NEMA 3R for indoor or outdoor installation:
  - DO NOT locate in direct sunlight.
  - In order to maintain NEMA 3R, plug all unused openings.

**CAUTION:** The control box is an above ground component of the submersible motor providing easy access to the starting system so you can perform maintenance without pulling the motor from the well. Be certain that the control box and motor hp and voltage match.

### The Start Relay

The potential (voltage sensing) relay has normally closed contacts. When power is first applied, both motor windings (main and start) are energized. The relay's normally closed contacts place the start capacitor in the circuit (in series) with the start winding, providing extra torque to bring the motor up to speed. The relay does this by sensing the voltage across the start winding. At the initial moment when power is first applied, the voltage across the start winding is not high enough to open the contacts of the relay. The relay is designed to pick up, open its contacts, and disconnect the start capacitor from the start winding when sufficient voltage is generated. Since the voltage generated by the start winding is proportional to motor speed, the relay will open only when the motor has started and is approaching normal running speed. When the windings approach full speed, they magnetize the relay's coil and physically break the connection (opens the relay contacts) to the start winding. This takes both the start winding and start capacitor out of the circuit, leaving the motor to run only on the main winding.

### The Start Capacitor

The start capacitor provides more starting torque to bring the motor up to full speed. Start capacitors are designed for intermittent service only and have a high microfarad (MFD) rating. When used with a potential relay, a start capacitor requires a bleed resistor soldered across its terminals. The bleed resistor will lengthen the relay and capacitor life when the motor cycles (run time) are short due to, for example, an undersized pressure tank providing insufficient drawdown gallons. Whenever a motor cycles on, start capacitors are left with a high voltage DC charge during the run time. If the motor runs several minutes, most of this charge is lost within the capacitor itself and an added bleed resistor would not be needed. However, following a very short run time the start capacitor could discharge through the relay contacts as they close during coast-down, causing arcing and overheating of the relay contacts. The added resistor bleeds off the charge within seconds, preventing sticking relay contacts and/or erratic relay operation especially where short cycling is likely to occur.

**For specific ratings of individual components, refer to the CONTROL BOXES chart on the OPERATING DATA PAGE.**

# LANCASTER HYDRO-FORCE™

## 3-Wire Control Box

### Troubleshooting

#### **Troubleshooting procedures with POWER ON**

**WARNING: Fatal electrical shock hazard. Do not touch any live parts.** Only qualified persons should perform the following procedures.

#### **Measure Voltage...**

- **With control box lid removed:** the motor cannot run because the electrical components on the lid are removed from the circuit. Measure line voltage by placing a voltmeter across the L1 and L2 terminals in the control box.
- **With control box lid attached:** the motor can run because the electrical components on the lid complete the circuit; voltage cannot be measured from inside the box. Measure line voltage by placing a voltmeter across the L1 and L2 terminals of the pressure switch. The voltage reading should remain the same except for a slight drop at startup. Excessive voltage drop could be caused by loose connections, bad contacts, ground faults or insufficient power supply.  
*Control box relay “chatter” is caused by low voltage or ground faults.*

**Voltage reading should be 230V +6%/-10%.**

#### **Measure Current (Amps)...**

- **With control box lid attached:** the motor can run because the electrical components on the lid complete the circuit; current cannot be measured from inside the box. Measuring the amount of current between the control box and motor is helpful when troubleshooting because it can indicate the operating conditions of the motor. If the measured motor current exceeds Service Factor Max Amps (SFA) the motor is running in a possible overload condition. This could be caused by the pump operating at open discharge or on the far right side of the pump curve. A bound pump will cause Locked Rotor Amps and overload tripping. If the measured motor current is much lower than expected the motor is in a possible under-load condition. This could be caused by the pump running at shut-off (dead-head) pressure, a stripped spline (motor shaft-pump coupling), a plugged pump intake screen or blocked system piping thereby restricting flow. A clamp-on ammeter can be used to measure amp draw in the yellow lead (line amps), black lead (main winding amps) and red lead (start winding amps). **In some installations the leads from the control box to the motor will be in conduit or otherwise difficult to access. If it is possible to measure current in the motor leads...**
  1. Current in the yellow and black leads will spike at startup and then come down in less than 1 second.
  2. Current in the red lead should momentarily be high at startup and then drop within 1 second. This verifies proper control box relay operation.  
*Control box relay failure will cause the red lead current to remain high and overload tripping.*  
*Control box start capacitor failure or an open relay is indicated by the red lead current not momentarily high at startup.*

**Amp readings should not exceed values listed in the 3-WIRE MOTORS chart on the OPERATING DATA PAGE.**

**Refer to Troubleshooting procedures with POWER OFF for control box component diagnostic testing.**

# LANCASTER HYDRO-FORCE™

## 3-Wire Control Box

### Troubleshooting

#### Troubleshooting procedures with POWER OFF

Control box component diagnostic testing: **CAUTION- Make sure the power is turned off.**

#### Start Capacitor...

- 1) **Physical Inspection** – If the vent (a small rubber diaphragm located at the top end of the start capacitor's plastic case) is bulging, or if a foul smell or a buildup of black soot is evident, the start capacitor has vented due to exposure to over-current, heat or prolonged use. Do not attempt to the run submersible well pump with a bulging, leaking, or damaged start capacitor. It must be replaced.
- 2) **Test the Start Capacitor – CAUTION** -The first operation in testing a capacitor is to discharge it. Holding a screwdriver by its insulated (plastic or wood) handle and using the screwdriver's metal shank to make contact between the capacitor's terminals will short out the terminals but can also damage the capacitor. To avoid electric shock NEVER place fingers across the terminals before properly discharging the capacitor. The start capacitor has a bleed resistor soldered across the terminals. The added resistor bleeds off the charge.
  - a) **Test capacitor using an ohmmeter**- capacitors can be roughly checked using an ohmmeter. Disconnect the wiring from the capacitor terminals but keep the bleed resistor in place. Set the ohmmeter scale to R x 1000. Connect the ohmmeter test leads to the capacitor terminals. What you are actually doing is attempting to charge the capacitor using the battery in the ohmmeter (make sure the battery in the ohmmeter is good).

**Good Capacitor:** the ohmmeter indicator should first move towards zero and then drift back, settling at the resistor value of approximately 15,000 ohms or 15 on the R x 1000 scale. Note- if the resistor was removed from the capacitor terminals, the indicator will first move towards zero and then increase back towards infinity. If the resistor is not damaged, re-solder it across the capacitor terminals. Otherwise attach and solder a new 15,000-18,000 ohm, two watt bleed resistor across the terminals.

*Note- using an ohmmeter and getting a good capacitor test result as described above only indicates that the capacitor will hold a charge but not how much charge. The use of a capacitor tester is highly recommended (see 2b.).*

**Open Capacitor:** the indicator will read high with no dip and no recovery. Replace defective capacitor.

**Shorted Capacitor:** the indicator moves towards zero and stays at zero. The capacitor has an internal short and will not take the charge. Replace defective capacitor.
  - b) **Test capacitor using capacitor tester**- capacitors can be checked more accurately by using a capacitor test meter that measures capacitance (the ability of the capacitor to store an electrical charge) in microfarads (MFD). Most digital multimeters now have scales for testing capacitors. Disconnect the wiring from the capacitor terminals and cut off the bleed resistor wire from one capacitor terminal (leave enough wire to re-solder resistor to terminal if capacitor tests good). Push resistor wire away from capacitor terminal. Set the capacitor tester to the correct MFD scale or if using a digital multimeter set the meter to the capacitance test function. Connect the meter test leads to the capacitor terminals. Measured capacitance should be within the MFD range printed on the capacitor. If the meter reads that the capacitor failed to hold its rating, replace the defective capacitor. For single value MFD ratings, the rule of thumb is to replace the capacitor if capacitance drops below 10% of the original value. **If printing on the capacitor is unreadable, refer to CONTROL BOXES chart on the OPERATING DATA PAGE for MFD values.**

## Start Relay (a.k.a. Potential or Voltage Relay)...

- 1) **Physical Inspection** – A faint click from inside the control box can be heard very shortly after the submersible pump motor starts, i.e. the relay contacts should be closed during the initial starting cycle, but should open (faint click) as the motor comes up to speed. If the relay “chatters”, i.e. clicks quickly and repeatedly, the supply voltage could be low. The start relay is designed to operate **ONLY** on 230-volt systems. If the submersible pump attempts to start, but is unable to do so or if there is a humming sound, check the relay to see if the contacts are damaged or its coil opened.  
*Note - Sticking relay contacts (contacts that will not open as described previously) could be damaged from a defective start capacitor bleed resistor.*
- 2) **Test the Start Relay** – Disconnect wiring from the start relay.
  - a) Test the relay coil using an ohmmeter- Set the ohmmeter scale to R x 1000. Connect the ohmmeter test leads to #2 & #5 on the relay.  
**Coil resistance correct reading:** 4.5 – 7.0 (4,500 to 7,000 ohms).
  - b) Test the relay contact using an ohmmeter- Set the ohmmeter scale to R x 1. Connect the ohmmeter test leads to #1 & #2 on the relay.  
**Contact resistance correct reading:** Zero.  
*Note- relay contacts are normally closed and measured resistance should be zero (0 ohms). Higher resistance readings indicate deterioration of the contacts.*

## Control Box Wiring Diagram 1/2, 3/4 & 1 HP 230 V - 60 HZ

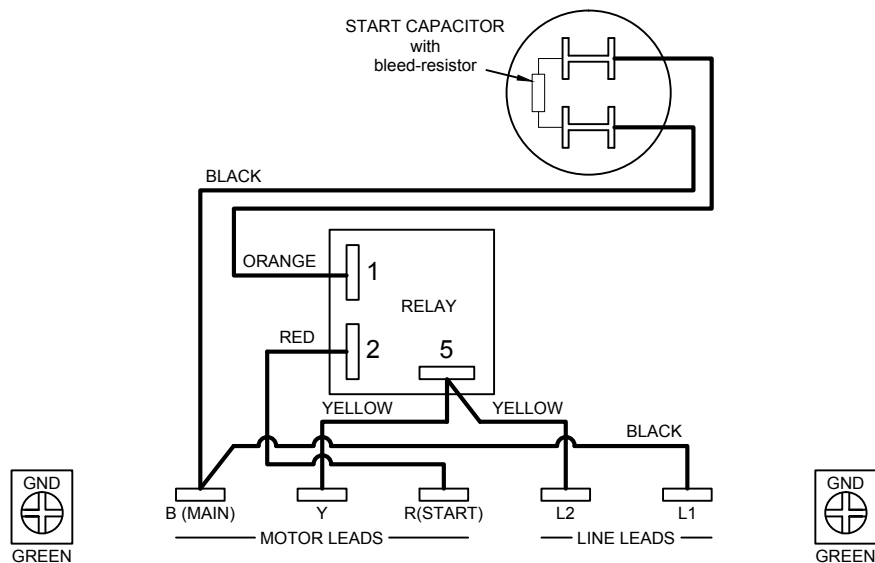

AUGUST 2014

# LANCASTER PUMP

A DIVISION OF C-B TOOL CO.

1340 MANHEIM PIKE • LANCASTER PA 17601-3196 • TEL: 717-397-3521 • FAX: 717-392-0266

[www.lancasterpump.com](http://www.lancasterpump.com) • E-mail: [info@lancasterpump.com](mailto:info@lancasterpump.com)