

Features

- Brass construction and valve bodies.
- Durable polished chrome plate finish.
- Quarter-turn washerless ceramic disc valves.
- Vandal-resistant aerator.
- Vandal proof ADA compliant wristblade handle with red and blue indexing.
- For 8" (203 mm) centers.
- 8-3/16" (208 mm) swing spout.
- Less drain.
- Low Lead- Safe Drinking Water Act (SDWA) compliant.
- Matching finish sidespray with integral diverter.

Material

- 1.8 gpm (6.8 lpm) maximum flow rate at 60 psi (4.1 bar).

Recommended Products/Accessories

K-23723 Faucet cleaner



ADA **CSA B651**

Codes/Standards

ASME A112.18.1/CSA B125.1

NSF/ANSI 61

NSF/ANSI 372

All applicable US Federal and State material regulations

DOE - Energy Policy Act 1992

California Energy Commission (CEC)

ADA

ICC/ANSI A117.1

CSA B651

KOHLER® One-Year Limited Warranty

See website for detailed warranty information.

Available Colors/Finishes

Color tiles intended for reference only.

Color	Code	Description
-------	------	-------------

	CP	Polished Chrome
---	----	-----------------

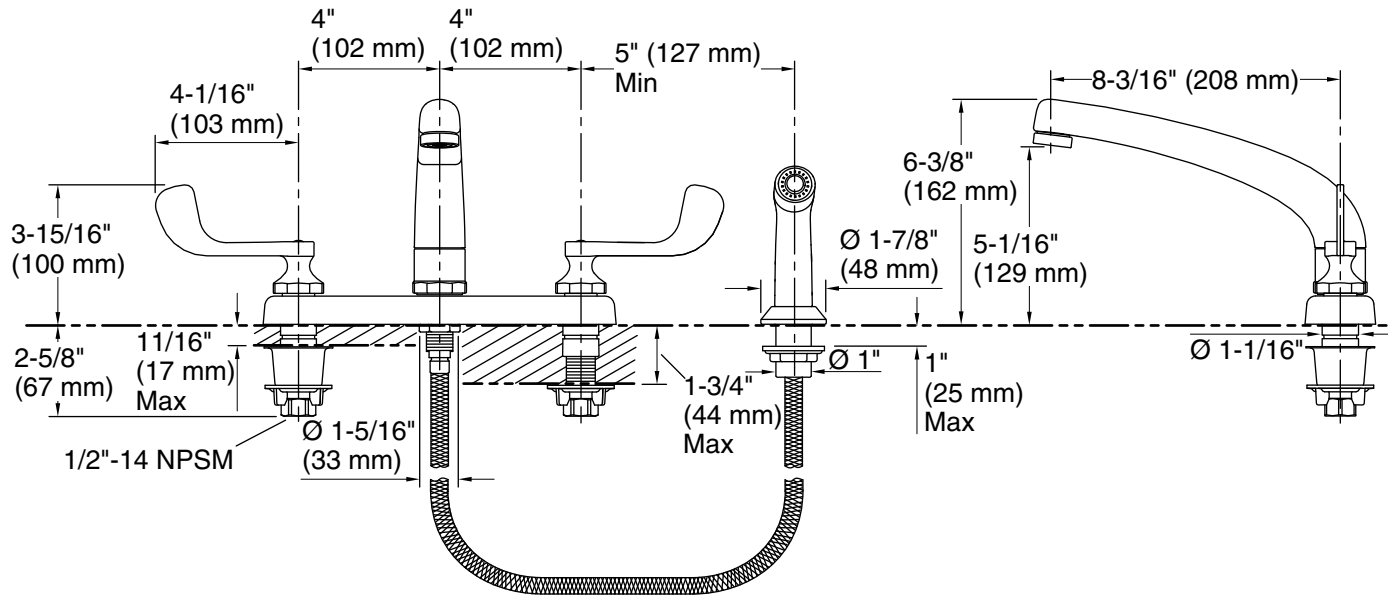

Technical Information

All product dimensions are nominal.

Faucet:

Flow rate: 1.8 gal/min (6.8 l/min)

Pressure: 60 psi (4.1 bar)

Sidespray:

Flow rate: 1.2 gal/min (4.5 l/min)

Pressure: 60 psi (4.1 bar)

Spout:

Spout reach: 8-3/16" (208 mm)

Notes

Install this product according to the installation guide.

Drill the hole for the sidespray a minimum of 5" (127 mm) from the center of the lever handle.

ADA compliant for faucet handles only.

ADA, CSA B651 compliant when installed to the specific requirements of these regulations.