

# MAGNA3

Model D

Circulator pumps

60 Hz



<b>1. Product description</b>	<b>3</b>	<b>12. Grundfos Product Center</b>	<b>62</b>
Type key	4		
Model type	4		
Pump heads in twin-head pumps	4		
Performance range, MAGNA3	5		
Performance range, MAGNA3 D single-head operation	6		
Performance range, MAGNA3 D twin-head operation	7		
<b>2. Product range</b>	<b>8</b>		
<b>3. System applications</b>	<b>10</b>		
Heating systems	10		
Cooling systems	11		
Solar-heating systems	13		
<b>4. Functions</b>	<b>14</b>		
Control modes: Quick overview	15		
Operating modes	17		
Control modes	17		
Additional control mode features	22		
Multipump modes	23		
Setting values for control modes	24		
Flow estimation accuracy	24		
Readings and settings on the pump	26		
Communication	28		
<b>5. Operating conditions</b>	<b>34</b>		
General recommendations	34		
Pumped liquids	34		
Electrical data	35		
<b>6. Construction</b>	<b>36</b>		
<b>7. Installation</b>	<b>39</b>		
Mechanical installation	39		
Electrical installation	39		
Connection to power supply, terminal-connected versions	40		
<b>8. Curve conditions</b>	<b>41</b>		
Performance curves	41		
Energy efficiency index (EEI)	41		
QR code on the pump nameplate	41		
Markings and approvals	42		
<b>9. Performance curves and technical data</b>	<b>43</b>		
<b>10. Accessories</b>	<b>56</b>		
CIM modules	56		
Grundfos Remote Management	56		
Grundfos GO	57		
External Grundfos sensors	58		
Cable for sensors	59		
Blanking flange	59		
Pipe connections	60		
<b>11. Product numbers</b>	<b>61</b>		
Single-head pumps	61		
Twin-head pumps	61		

# 1. Product description



TM05 8894 2813

The Grundfos MAGNA3 model D circulator pumps are designed for circulating liquids in systems with variable flow requirements where you want to optimize the setting of the pump duty point, thus reducing energy costs.

## Applications

- Heating systems
  - main pump
  - mixing loops
  - heating surfaces
- air-conditioning and cooling systems
- domestic hot-water systems
- ground source heat-pump systems
- solar-heating systems.

The MAGNA3 circulator pump is perfect for both new systems as well as for replacement. The pump is ideal when operating in systems requiring an automated adjustment of pressure. This pump range is the best choice as it eliminates the need for expensive bypass valves and similar components.

Furthermore, the pump is appropriate for systems with hot-water priority as an external signal can immediately force the pump to operate according to the maximum curve, for example in solar-heating systems. When using the pumps in domestic hot-water systems, please observe local legislation regarding pump house material. Grundfos strongly recommends that you use stainless-steel pumps in domestic hot-water applications to avoid corrosion.

## Duty range

Data	MAGNA3 (N) Single-head pumps	MAGNA3 D Twin-head pumps
Maximum flow rate	345 gpm (78.5 m <sup>3</sup> /h)	660 gpm (150 m <sup>3</sup> /h)
Maximum head	60 ft (18 m)	
Maximum system pressure	175 psi (1.2 MPa) (12 bar)	
Liquid temperature	14 to 230 °F (-10 to +110 °C)	

To ensure correct operation, it is important that the duty points in the system match the duty range of the pump.

## Characteristic features

- AUTO<sub>ADAPT</sub>.
- FLOW<sub>LIMIT</sub>.
- FLOW<sub>ADAPT</sub> - a combination of the AUTO<sub>ADAPT</sub> control mode and FLOW<sub>LIMIT</sub> function.
- Built-in Grundfos differential-pressure and temperature sensor.
- Proportional-pressure control.
- Constant-pressure control.
- Constant-temperature control.
- Constant-curve duty.
- Maximum or minimum curve duty.
- Automatic night setback.
- Self-explanatory user interface with TFT display and high quality silicone push-buttons.
- Heat energy monitor.
- Wireless multipump function.

The complete range is available for a maximum system pressure of 175 psi (12 bar, 1.2 MPa), PN 12.

## Benefits

- Low energy consumption due to the AUTO<sub>ADAPT</sub> function, allowing the pump to adjust automatically to external factors, such as outside temperatures and consumption patterns.
- Simple installation.
- No maintenance and long life.
- Operating log history.
- Easy and simple system optimization.
- External control and monitoring enabled via add-on modules.
- No external motor protection required.
- Insulating shells for heating systems supplied with single-head pumps.
- Wide temperature range due to thermal separation of the control box and pump media.

### Type key

Code	Example	MAGNA3	(D)	80	-120	(F)	(N)	360
	<b>Type range</b> MAGNA3							
D	Single-head pump Twin-head pump							
	Nominal diameter (DN) of inlet and outlet ports [mm]							
	Maximum head [dm]							
F	<b>Pipe connection</b> Flange							
N	<b>Pump housing material</b> Cast iron Stainless steel							
	Port-to-port length [mm]							

### Model type

This data booklet covers MAGNA3 model D. The model version is stated on the nameplate. See fig. 1.



Fig. 1 Model type on pump nameplate

TM06 7734 4017

### Pump heads in twin-head pumps

The twin-head pump housing has a flap valve on the outlet side. The flap valve seals off the port of the idle pump housing to prevent the pumped liquid from running back to the inlet side. See fig. 2. Due to the flap valve, there is a difference in the hydraulics between the two heads. See fig. 3.



Fig. 2 Twin-head pump housing with flap valve

TM06 1565 2514

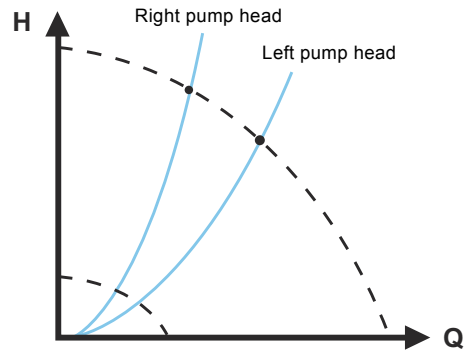
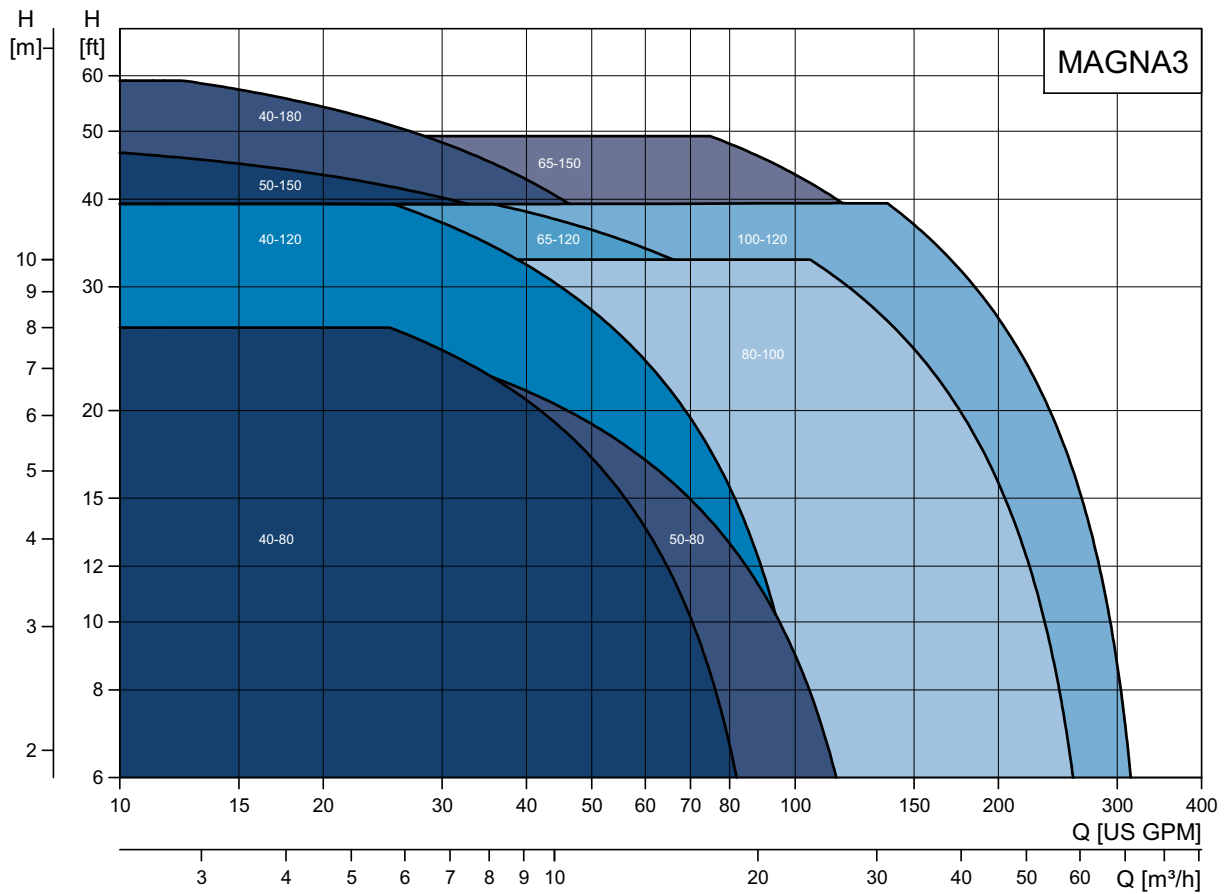

Fig. 3 Hydraulic difference between the two heads

TM06 1566 2514

### Performance range, MAGNA3



TM05 7654 3817

Fig. 4 Performance range, MAGNA3

Performance range, MAGNA3 D single-head operation

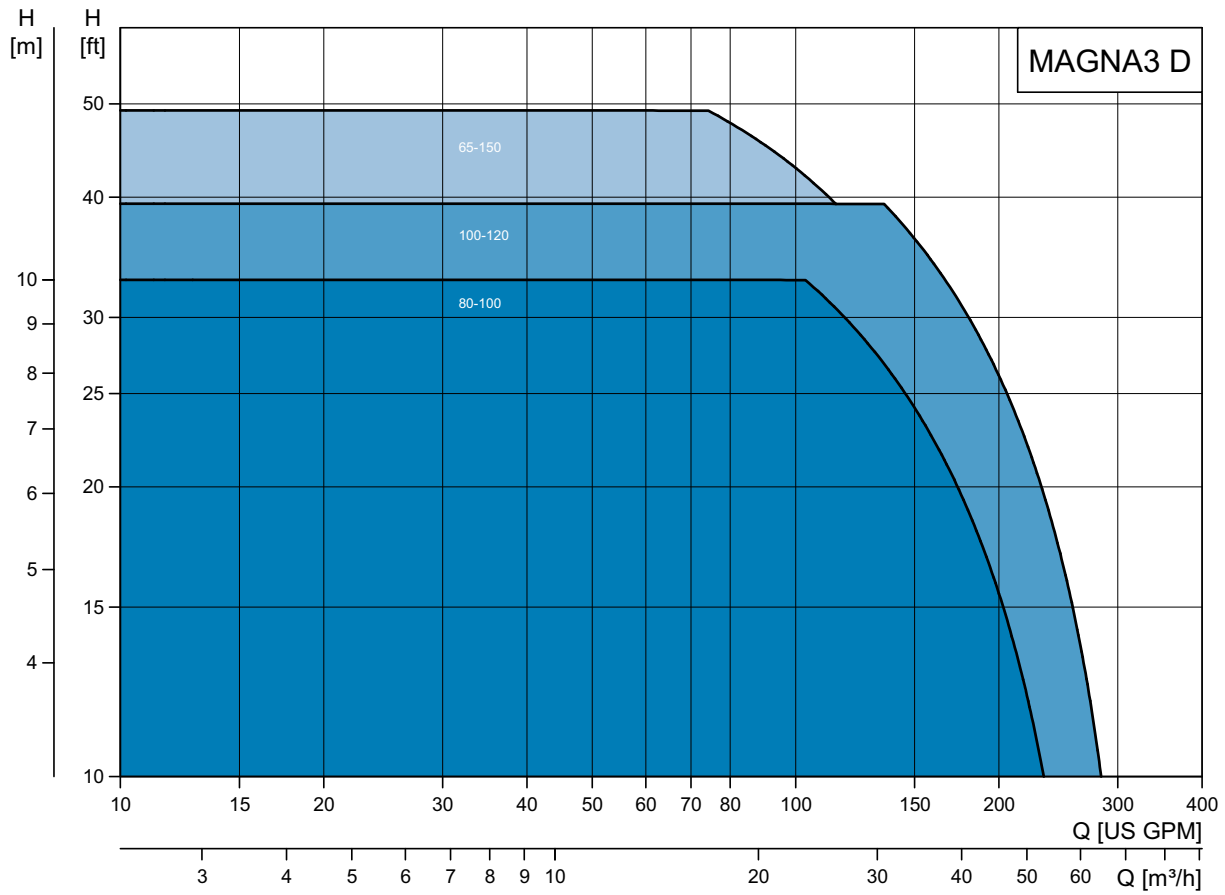

TM05 7655 3717

Fig. 5 Performance range, MAGNA3 D single-head operation

Performance range, MAGNA3 D twin-head operation

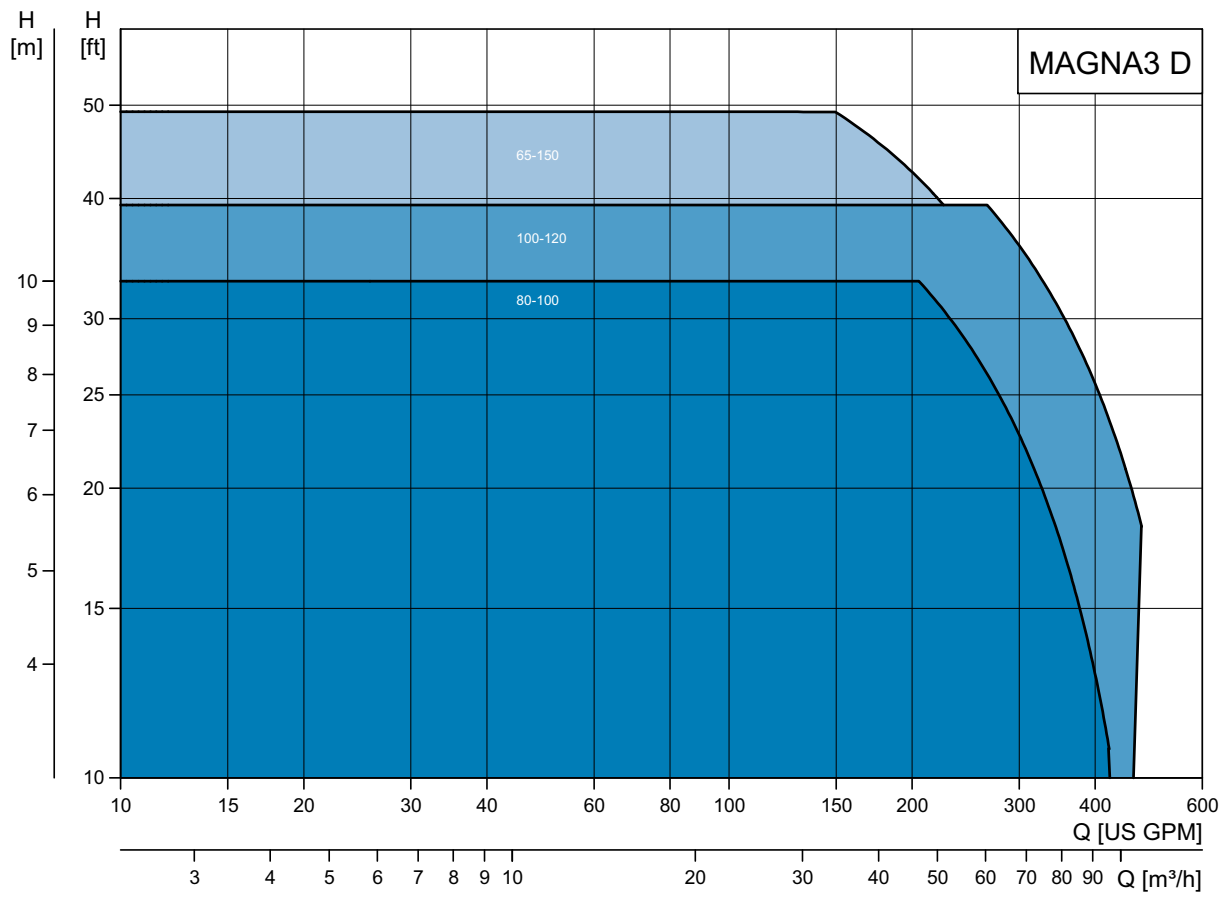

TN05 7656 3717

Fig. 6 Performance range, MAGNA3 D twin-head operation

## 2. Product range

	Cast iron		Stainless steel (N)		Page reference
	115 V	230 V	115 V	230 V	
<b>Single-head pump models</b>					
MAGNA3 40-80 F (N)	98126800	98126828	98126802	98126830	44
MAGNA3 40-120 F (N)	98126804	98126832	98126806	98126834	45
MAGNA3 40-180 F (N)	98126808	98126836	98126810	98126838	46
MAGNA3 50-80 F (N)	98126812	98126840	98126814	98126842	47
MAGNA3 50-150 F (N)	98126816	98126844	98126818	98126846	48
MAGNA3 65-120 F (N)	98124696	98126848	98124702	98126850	49
MAGNA3 65-150 F (N)	-	98126852	-	98126854	50
MAGNA3 80-100 F (N)	-	98126856	-	98126858	52
MAGNA3 100-120 F (N)	-	98126860	-	98126862	54
<b>Twin-head pump models</b>					
MAGNA3 D 65-150 F	-	98126863	-	-	51
MAGNA3 D 80-100 F	-	98126864	-	-	53
MAGNA3 D 100-120 F	-	98126865	-	-	55

### Pump selection

All pumps have a "best point" ( $\eta_{max}$ ), indicating where the pump is working most efficiently.

Consider the parameters in the following section.

### Pump size

The system characteristic is used together with the performance curve of the pump for sizing and correct pump selection.

The selection of pump size must be based on the following:

- required maximum flow
- maximum pressure loss in the system.

Refer to the system characteristics to determine the duty point. See fig. 7.

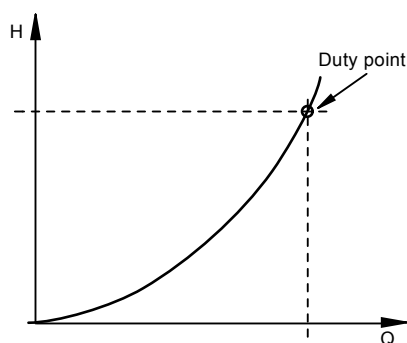

Fig. 7 System characteristic

TM02 2040 3301

### Operating conditions

You must check whether the operating conditions are fulfilled, i.e.:

- liquid quality and temperature
- ambient conditions
- minimum inlet pressure
- maximum operating pressure.

See also *Operating conditions*, page 34.

### Closed valve operation

A MAGNA3 pump can operate at any speed against a closed valve for several days without damage to the pump. However, Grundfos recommends to operate at the lowest possible speed curve to minimize energy losses. There are no minimum flow requirements.

**Note:** Do not close inlet and outlet valves simultaneously, always keep one open when the pump is running. Media- and ambient temperatures must never exceed the specified temperature range.



## Control modes

- $AUTO_{ADAPT}$  (factory setting) which is suitable for most installations.
- $FLOW_{ADAPT}$  in systems where flow limitation is required.
- Proportional-pressure control in systems with considerable pressure losses in relation to large flow variations.
- Constant-pressure control in systems with insignificant pressure losses in relation to large flow variations.
- Constant-temperature control in heating systems with a fixed system characteristic, for example domestic hot-water systems.
- Differential-temperature control in heating and cooling systems.
- Constant-curve duty.

For further information on control and operating modes, see *Functions*, page 14.

### Automatic determination of the setpoint

If you know the duty point, you can enter the value on the display when setting the pump. The pump then automatically calculates the corresponding setpoint. See fig. 8.

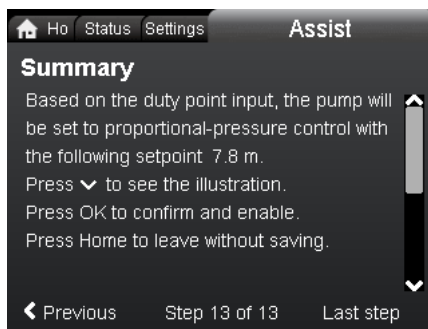

4.1.1.0.0.0 - 13A

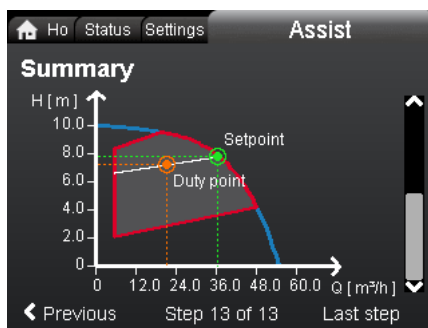

4.1.1.0.0.0 - 13B

**Fig. 8** Example of setpoint calculation based on a chosen control mode and entered Q and H values

## Communication

The Grundfos CIM modules (Communication Interface Module) enable the MAGNA3 to connect to standard fieldbus networks, offering substantial benefits:

- complete process control and monitoring
- modular design, prepared for future requirements
- based on standard functional profiles
- simple configuration and easy installation
- open communication standards
- reading warning and alarm indications.

For further details, see *CIM modules*, page 28.

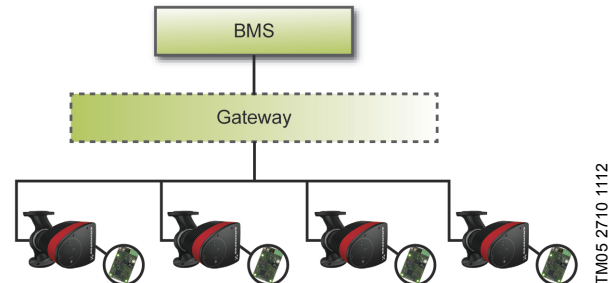

TM05 2710 1112

**Fig. 9** Example of a typical building management system (BMS)

**Note:** A gateway is a device that facilitates the transfer of data between two different networks based on different communication protocols.

## 3. System applications

### Heating systems

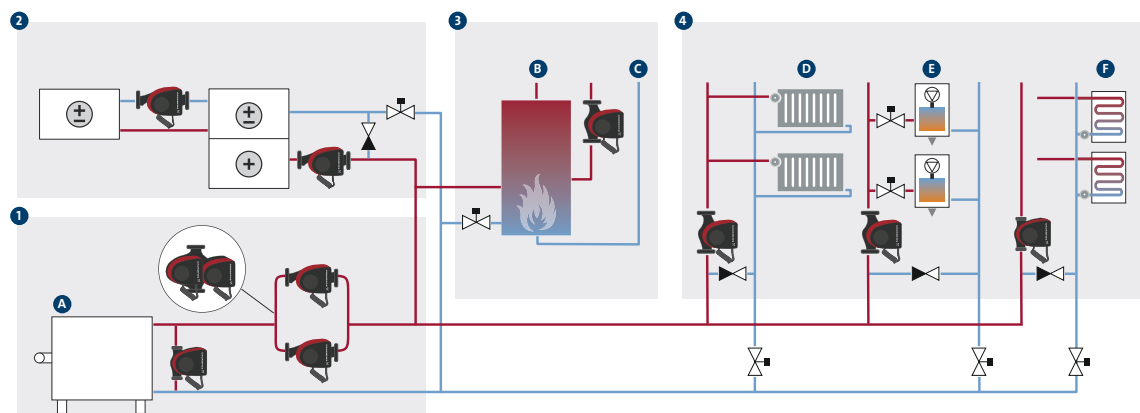

Fig. 10 Functional drawing of a heating system in a commercial building

Pos.	Description
1	Main pumps
A	Boiler
2	Air handler heating coils
3	Domestic hot water
B	Hot-water circulation
C	Cold water
4	Mixing loops
D	Radiators
E	Fan coils
F	Underfloor heating

#### Main pumps

Due to variations in the heat demand and flow rate, we always recommend that you use speed-controlled MAGNA3 pumps in a heating system, either single-head pumps connected in parallel or twin-head pumps. Single-head pumps connected in parallel have several advantages. In alternating operation, each pump is sized for 100 % flow. In this operating mode, the second pump functions as backup for higher reliability. As the pumps alternate, an equal number of operating hours is ensured. Cascade operation of pumps connected in parallel meets demands in high-flow systems with low differential temperature ( $\Delta t$ ), and 50 % backup is ensured at the same time.

The twin-head pump saves installation time and costs. By speed-controlling all pumps, you can obtain maximum energy saving as the pumps will run at their best efficiency point (BEP).

In a variable-flow system, we recommend that you control the main pump in  $AUTO_{ADAPT}$  or proportional-pressure mode.

However, if a load (e.g. a radiator) is far from the pump, it can be advantageous to install a differential pressure sensor across this load and use a setpoint for differential pressure.

By using the  $FLOW_{ADAPT}$  function to ensure correct balancing of the system, the need for pump throttling valves can be reduced significantly.

The built-in heat energy monitor allows monitoring of the heat energy consumption in the system only for optimization purposes.

#### Air handler heating coils

The performance of heating surfaces is controlled by the heating-water temperature and the flow rate. For this purpose, we recommend that you install variable-flow mixing loops at the heating surfaces. A speed-controlled mixing-loop pump is ideal for adaptation to the varying loads in a heating surface. In this case, MAGNA3 will have full authority, making external pump throttling valves superfluous.

#### Domestic hot water

For domestic hot-water circulation, the constant-temperature control mode will ensure a constant temperature in the recirculation pipe, without the use of separate thermostatic valves, thus obtaining maximum comfort.

#### Mixing loops

Due to variations in use, flow-pipe temperature and heat demand in different parts of the building, the heating system must be divided into zones controlled by independent mixing loops. Due to the flow variations, a speed-controlled mixing-loop pump will have authority in the system. This will help obtain a better hydraulic balance in the overall system. Speed control of the pump via selection of a control mode, depending on system application, ensures maximum energy saving. See *Control modes*, page 17.

Advantages of using mixing loops:

- Reduced excessive differential pressure in the system and hereby reduced risk of overflow
- increased control ability as the loop is provided with the exact flow and temperature demand.

TM05 2155 1312

## Cooling systems

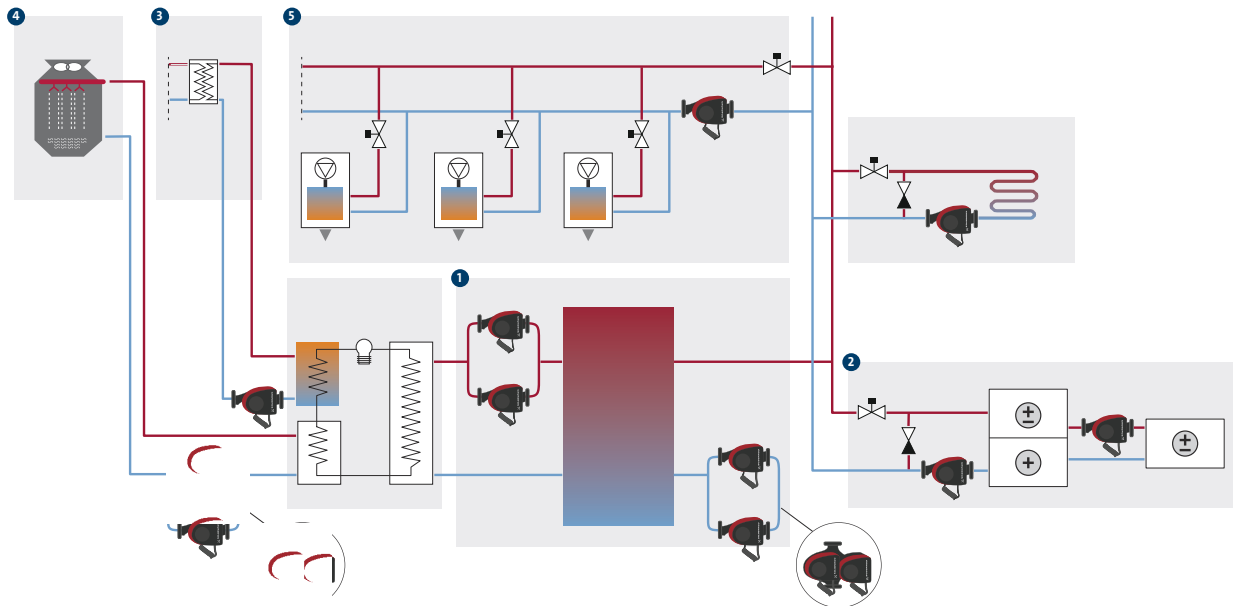

TM05 2156 1312

Fig. 11 Functional drawing of a cooling system in a commercial building

Pos.	Description
1	Primary and secondary pumps
2	Air handler cooling coils
3	Heat recovery system
4	Cooling tower
5	Mixing loops

### Primary and secondary pumps

Due to variations in the cooling demand and flow rate, we recommend that you use speed-controlled MAGNA3 pumps in a cooling system, either single-head pumps connected in parallel or twin-head pumps. Single-head pumps connected in parallel have several advantages. In alternating operation, each pump is sized for 100 % flow. In this operating mode, the second pump functions as backup for higher reliability. As the pumps alternate, an equal number of operating hours is ensured. Cascade operation of pumps connected in parallel meets demands in high-flow systems with low differential temperature ( $\Delta t$ ), and 50 % backup is ensured at the same time. The twin-head pump saves installation time and costs. By speed-controlling all pumps, you can obtain maximum energy saving as the pumps will run at their best efficiency point (BEP).

In a variable-flow system, we recommend that you control secondary pumps in  $AUTO_{ADAPT}$  or proportional-pressure mode with a differential-pressure sensor in the flow pipe with the lowest pressure. This ensures maximum energy saving.

The built-in heat energy monitor allows monitoring of the heat energy consumption in the system.

### Air handler cooling coils

The performance of cooling surfaces is controlled by the cooling-water temperature and the flow rate. For this purpose, we recommend that you install variable-flow mixing loops at the cooling surfaces. A speed-controlled mixing-loop pump is ideal for adaptation to the varying loads in a cooling surface. In this case, MAGNA3 will have full authority, eliminating the need for external pump throttling valves. The  $FLOW_{LIMIT}$  ensures that the rated flow is never exceeded.

### Heat recovery system

The heat recovery system is of paramount importance for the overall energy efficiency of an air-conditioning or cooling system. Due to high load and temperature variations in the system, it is important to use variable-speed pumps in a heat recovery system.

### Cooling tower

Due to chiller load variations and changes in the temperature and moisture of the ambient air, the cooling-tower flow rate is continuously changing. In order to achieve maximum energy saving, cooling-tower pumps have to be able to adapt to these varying conditions. The pumps are controlled by a temperature setpoint which is measured at the condenser of the chiller. In this system, MAGNA3 will have full authority, eliminating the need for pump throttling valves. The  $FLOW_{LIMIT}$  ensures that the rated flow is never exceeded.

**Mixing loops**

Due to the risk of condensation, the flow-pipe temperature through a cooling ceiling or floor must never be lower than the dew point temperature of the indoor air. The dew point temperature varies due to variations in indoor moisture load and outdoor thermal conditions. The result is that the cooling-water setpoint has to be controlled. A mixing loop is ideal for obtaining the correct temperature in order to adapt to the varying setpoint.

Due to continuous cooling-load variations in the building cooling zones, the cooling performance in cooling ceilings and floors is controlled by motor valves via zone control units, and therefore you must always use a speed-controlled mixing-loop pump.

## Solar-heating systems

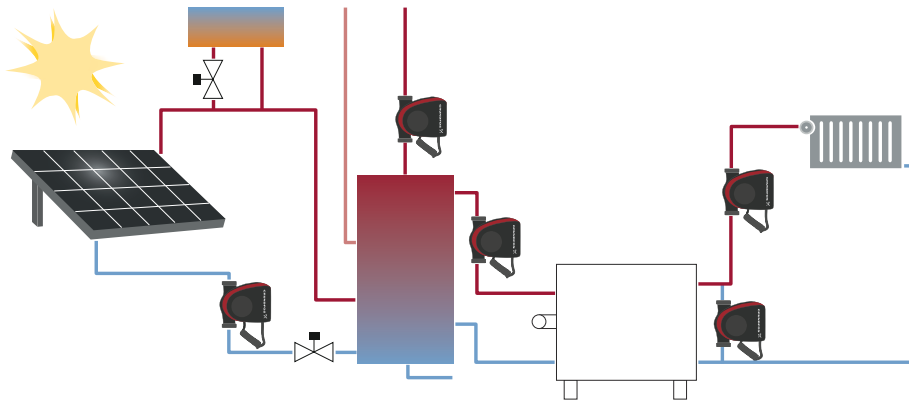

Fig. 12 Functional drawing of a solar-heating system

### Main pumps

Solar-heating systems operate with very low flow rates compared to other heating systems, however, with relatively large pressure losses. With a conventional circulator pump, the flow must be controlled with a valve resulting in a significantly higher power consumption. To achieve major reductions in energy consumption, MAGNA3 is optimized with the  $FLOW_{ADAPT}$  /  $FLOW_{LIMIT}$  control mode for operation specifically under these conditions.

### Ground source heat pump systems (GSHP)

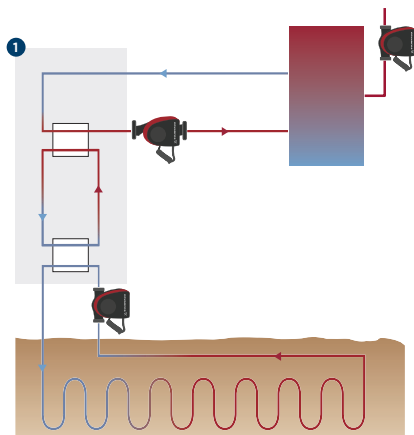

Fig. 13 Ground source heat pump system in a commercial building

Pos.	Description
1	Heat pump

### Main pumps

MAGNA3 is optimized for operation as a circulator pump in a closed-loop pipe system which is buried in the ground and filled with a mixture of water and antifreeze agent. MAGNA3 is therefore ideal for large ground source heat pump systems for commercial buildings.

MAGNA3 is designed for pumping liquids down to +14 °F (-10 °C). The pump can use all known antifreeze agent compositions.

It is important to note that all components are highly energy-efficient. No other circulator pump performs better in GSHP systems than MAGNA3 with the  $FLOW_{ADAPT}$  /  $FLOW_{LIMIT}$  control mode.

Use the benefit of the inputs and outputs of MAGNA3 to control the pump together with the heat pump.

### Installation and commissioning

When installing MAGNA3, no external pressure sensor or motor protection is required. Installation is simple thanks to the built-in differential-pressure and temperature sensor, which enables proportional-pressure control without the installation of a sensor in the system.

In systems where a differential pressure is desired at a certain point of the system, you must install an external pressure sensor. See *Electrical data*, page 35.

Pump selection is based on the required flow and calculated pressure losses. We recommend that you do not oversize the pump as it will lead to unnecessarily high energy consumption.

MAGNA3 features the  $FLOW_{LIMIT}$  function. In circuits where MAGNA3 has full authority, the need for external pump throttling valves is eliminated. The  $FLOW_{LIMIT}$  ensures that the rated flow is never exceeded.

TM05 3421 1312

TM05 3422 1312

## 4. Functions

	Page
<b>Operating modes</b>	17
Normal (control modes enabled)	17
Stop	17
Minimum curve	17
Maximum curve	17
<b>Control modes</b>	17
AUTO <sub>ADAPT</sub> (factory setting)	17
FLOW <sub>ADAPT</sub>	18
Proportional pressure	19
Constant pressure	19
Constant temperature	20
Differential temperature	20
Constant curve	21
<b>Additional control mode features</b>	22
FLOW <sub>LIMIT</sub>	22
Automatic Night Setback	23
<b>Multipump modes</b>	23
Alternating operation	23
Backup operation	23
Cascade operation	23
<b>Readings and settings on the pump</b>	26
Control panel and display	26
Operating status	26
Pump performance	26
Warning and alarm	26
Heat energy monitor	27
Operating log	27
Grundfos Eye (status indicator)	27
<b>Communication</b>	28
Wireless Grundfos GO	28
Wireless GENlair connection	28
Pump information to BMS via CIM modules	28
Bus via GENibus	29
Bus via LonWorks	29
Bus via PROFIBUS DP	29
Bus via Modbus RTU	29
Bus via BACnet MS/TP	29
Grundfos Remote Management	31
Digital inputs	31
Relay outputs	32
Analog input for external sensor	32
External setpoint function	33

## Control modes: Quick overview

### AUTO<sub>ADAPT</sub>

- We recommend this control mode for most heating systems.
- During operation, the pump automatically makes the necessary adjustment to the actual system characteristic.

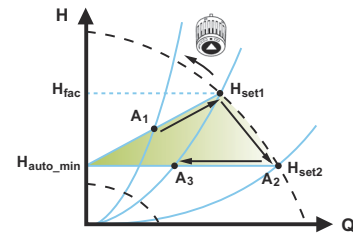

### FLOW<sub>ADAPT</sub>

The FLOW<sub>ADAPT</sub> control mode combines a control mode and a function:

- The pump is running in AUTO<sub>ADAPT</sub>.
- The delivered flow from the pump will never exceed a selected FLOW<sub>LIMIT</sub>.

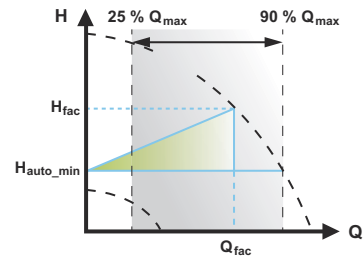

### Proportional pressure

- Used in systems with relatively large pressure losses in the distribution pipes.
- The head of the pump will increase proportionally to the flow in the system to compensate for the large pressure losses in the distribution pipes.

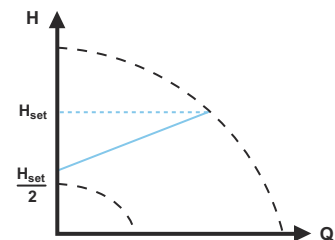

### Constant pressure

- We recommend this control mode in systems with relatively small pressure losses.
- The pump head is kept constant, independent of the flow in the system.

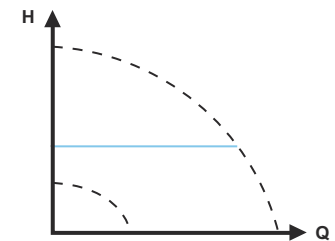

### Constant temperature

In heating systems with a fixed system characteristic, for example domestic hot-water systems, the control of the pump according to a constant return-pipe temperature is relevant.

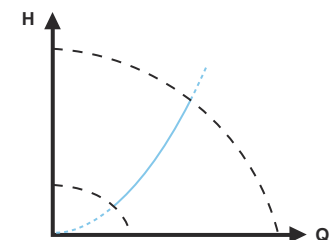

---

### Differential temperature

- Ensures a constant differential temperature drop across heating and cooling systems.
- The pump will maintain a constant differential temperature between the pump and the external sensor.

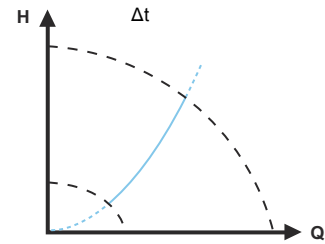

---

### Constant curve

- The pump can be set to operate according to a constant curve, like an uncontrolled pump.
- Set the desired speed in % of the maximum speed in the range from minimum to 100 %.

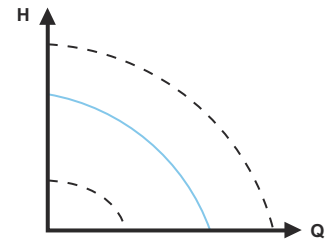

---

For multipump modes, see *Multipump modes*, page 23.



## Operating modes

### Normal

The pump runs according to the selected control mode.

**Note:** You can select the control mode and setpoint even if the pump is not running in Normal mode.

### Stop

The pump stops.

### Min.

You can use the minimum curve mode in periods where a minimum flow rate is required.

This operating mode is for instance suitable for manual night setback if automatic setback is not desired.

### Max.

You can use the maximum curve mode in periods where a maximum flow rate is required.

This operating mode is for instance suitable for hot-water priority.

You can select the normal, stop, min. and max. operating modes directly by use of the built-in digital inputs. See *Connection to power supply, terminal-connected versions*, page 40.

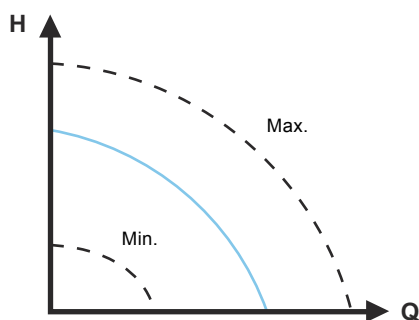

Fig. 14 Maximum and minimum curves

## Control modes

### Factory setting

The pumps have been factory-set to AUTO<sub>ADAPT</sub> without automatic night setback, which is suitable for most installations.

The setpoint has been factory-set. See *Setting values for control modes*, page 24.

## AUTO<sub>ADAPT</sub>

We recommend the AUTO<sub>ADAPT</sub> control mode for most heating systems, especially in systems with relatively large pressure losses in the distribution pipes, and in replacement situations where the proportional-pressure duty point is unknown.

This control mode has been developed specifically for heating systems and we do not recommend it for air-conditioning and cooling systems.

### Characteristics and key benefits

- Automatically adjusts the pump to actual system characteristics.
- Ensures minimum energy consumption and a low noise level.
- Reduced operating costs and increased comfort.

### Technical specifications

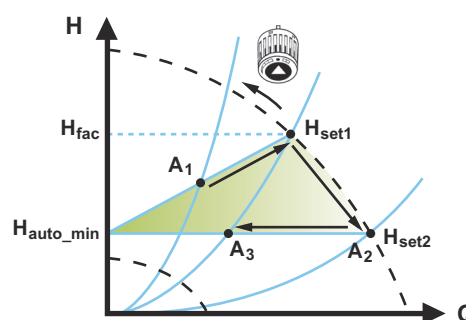

Fig. 15 AUTO<sub>ADAPT</sub> control

- A<sub>1</sub>: Original duty point
- A<sub>2</sub>: Lower registered head on the max. curve
- A<sub>3</sub>: New duty point after AUTO<sub>ADAPT</sub> control
- H<sub>set1</sub>: Original setpoint
- H<sub>set2</sub>: New setpoint after AUTO<sub>ADAPT</sub> control
- H<sub>fac</sub>: See page 24
- H<sub>auto\_min</sub>: A fixed value of 1.5 m

The AUTO<sub>ADAPT</sub> control mode is a form of proportional-pressure control where the control curves have a fixed origin, H<sub>auto\_min</sub>.

When you have enabled AUTO<sub>ADAPT</sub>, the pump will start with the factory setting, H<sub>fac</sub> = H<sub>set1</sub>, corresponding to approximately 55 % of its maximum head, and then adjust its performance to A<sub>1</sub>. See fig. 15.

When the pump registers a lower head on the maximum curve, A<sub>2</sub>, the AUTO<sub>ADAPT</sub> function automatically selects a correspondingly lower control curve, H<sub>set2</sub>. If the valves in the system close, the pump adjusts its performance to A<sub>3</sub>. See fig. 15.

**Note:** Manual setting of the setpoint is not possible.

TM05 2446 5111

TM05 2452 1312

## FLOW<sub>ADAPT</sub>

The FLOW<sub>ADAPT</sub> control mode combines AUTO<sub>ADAPT</sub> and FLOW<sub>LIMIT</sub>, meaning that the pump runs AUTO<sub>ADAPT</sub> while at the same time ensuring that the flow rate never exceeds the entered FLOW<sub>LIMIT</sub> value. This control mode is suitable for systems where a maximum flow limit is desired and where a steady flow through the boiler in a boiler system is required. Here, no extra energy is used for pumping too much liquid into the system.

In systems with mixing loops, you can use FLOW<sub>ADAPT</sub> to control the flow in each loop.

### Characteristics and key benefits

- The dimensioned flow for each zone (required heat energy) is determined by the flow from the pump. This flow rate can be set precisely in the FLOW<sub>ADAPT</sub> control mode without using throttling valves.
- When the flow rate is set lower than the balancing valve setting, the pump will ramp down instead of losing energy by pumping against a balancing valve.
- Cooling surfaces in air-conditioning systems can operate at high pressure and low flow.

**Note:** The pump cannot reduce the flow on the inlet side, but is able to control that the flow on the outlet side is at least the same as on the inlet side, as the pump has no built-in valve.

### Technical specifications

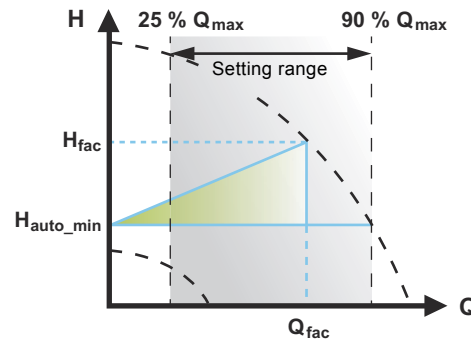

Fig. 16 FLOW<sub>ADAPT</sub> control

The factory setting of the FLOW<sub>ADAPT</sub> is the flow where the AUTO<sub>ADAPT</sub> factory setting meets the maximum curve. See fig. 16.

The typical pump selection is based on the required flow and calculated pressure losses. The pump is typically oversized by 30 to 40 % to ensure that it can overcome the pressure losses in the system. Under these conditions, the full benefit of AUTO<sub>ADAPT</sub> cannot be obtained.

To adjust the maximum flow of this "oversized" pump, balancing valves are built into the circuit to increase the resistance and thus reduce the flow.

The FLOW<sub>ADAPT</sub> function reduces the need for a pump throttling valve, see fig. 17, but does not eliminate the need for balancing valves in heating systems.

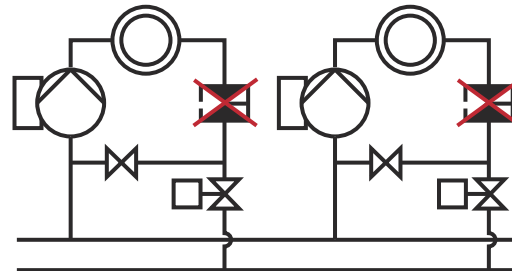

Fig. 17 Reduced need for a pump throttling valve

TM05 3334 1312

TM05 2685 1212

## Proportional pressure

Proportional pressure is suitable in systems with relatively large pressure losses in the distribution pipes and in air-conditioning and cooling systems:

- Two-pipe heating systems with thermostatic valves and the following:
  - very long distribution pipes
  - strongly throttled pipe balancing valves
  - differential-pressure regulators
  - large pressure losses in the parts of the system through which the entire amount of water flows, for example a boiler, heat exchanger and distribution pipe up to the first branching.
- Primary circuit pumps in systems with large pressure losses in the primary circuit.
- Air-conditioning systems with the following:
  - heat exchangers (fan coils)
  - cooling ceilings
  - cooling surfaces.

### Characteristics and key benefits

- The head of the pump increases proportionally to the flow in the system.
- Compensates for large pressure losses in the distribution pipes.

### Technical specifications

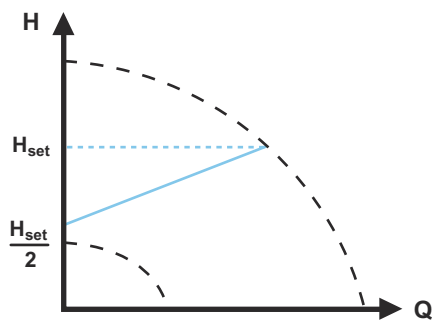

Fig. 18 Proportional-pressure control

The head against a closed valve is half the setpoint  $H_{set}$ .

TM05 2448 1212

## Constant pressure

A constant pressure is advantageous in systems with relatively small pressure losses in the distribution pipes:

- Two-pipe heating systems with thermostatic valves:
  - dimensioned for natural circulation
  - small pressure losses in the parts of the system through which the entire amount of water flows, for example a boiler, heat exchanger and distribution pipe up to the first branching.
  - modified to a high differential temperature between the flow pipe and the return pipe (for example district heating).
- Underfloor heating systems with thermostatic valves.
- One-pipe heating systems with thermostatic valves or pipe balancing valves.
- Primary circuit pumps in systems with small pressure losses in the primary circuit.

### Characteristics and key benefits

- The pump pressure is kept constant, independent of the flow in the system.

### Technical specifications

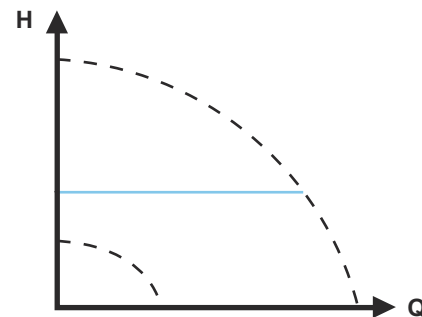

Fig. 19 Constant-pressure control

TM05 2449 0312

## Constant temperature

This control mode is suitable in heating systems with a fixed system characteristic, for example domestic hot-water systems, where the control of the pump according to a constant return-pipe temperature is relevant.

### Characteristics and key benefits

- The temperature is kept constant.
- $FLOW_{LIMIT}$  is used to control the maximum circulation flow.

### Technical specifications

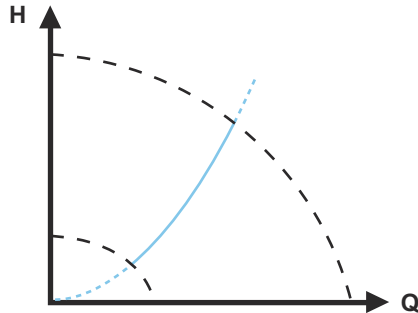

Fig. 20 Constant-temperature control

The inverse control for cooling application is available from model B.

### Temperature sensor

If the pump is installed in the flow pipe, install an external temperature sensor in the return pipe of the system. See fig. 21. Install the sensor as close as possible to the consumer (radiator, heat exchanger, etc.).

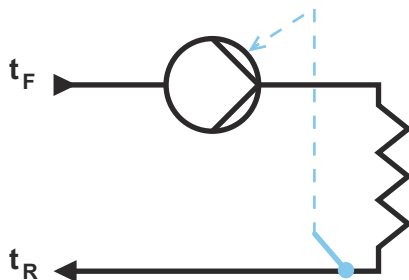

Fig. 21 Pump with an external sensor

If the pump is installed in the return pipe of the system, you can use the internal temperature sensor. In this case, install the pump as close as possible to the consumer (radiator, heat exchanger, etc.).

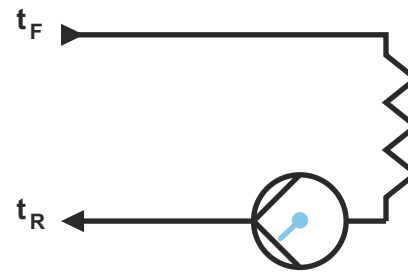

Fig. 22 Pump with an internal sensor

## Differential temperature

Select this control mode if the pump performance is to be controlled according to a differential temperature in the system where the pump is installed.

### Characteristics and key benefits

- Ensures a constant differential temperature drop across heating and cooling systems.
- Ensures a constant differential temperature between the pump and the external sensor, see figs 23 and 24.
- Requires two temperature sensors, the internal temperature sensor together with an external sensor.

### Technical specifications

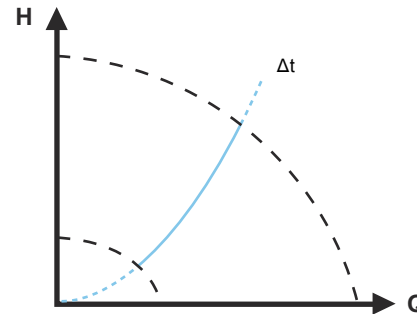

Fig. 23 Differential temperature

### Temperature sensor

To measure the temperature difference of the flow pipe and the return pipe, you must use both the internal sensor and an external sensor. If the pump is installed in the flow pipe, the external sensor must be installed in the return pipe and vice versa. Always install the sensor as close as possible to the consumer (radiator, heat exchanger, etc.). See fig. 24.

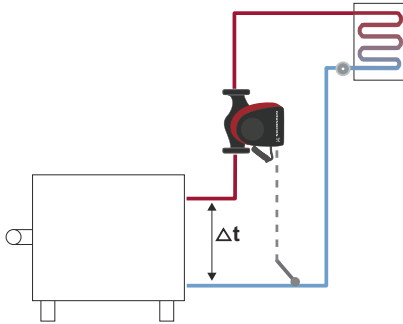

Fig. 24 Differential temperature

### Constant curve

A constant curve is suitable for systems, where both a constant flow rate and a constant head are required, i.e.:

- Heat surfaces
- cooling surfaces
- heating systems with 3-way valves
- air condition system with 3-way-valve
- chiller pumps

#### Characteristics and key benefits

- If an external controller is installed, the pump is able to change from one constant curve to another, depending on the value of the external signal.
- Depending on your preferences, the pump can be controlled according to either a maximum or minimum curve.

#### Technical specifications

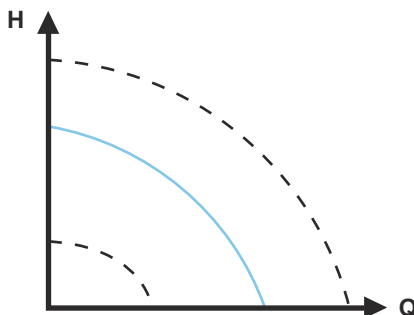

Fig. 25 Constant-curve duty

The pump can be set to operate according to a constant curve, like an uncontrolled pump. See fig. 25.

Depending on the pump model, you can set the desired speed in % of the maximum speed. The span of control depends on the minimum speed, power and pressure limitation of the pump.

**Note:** If the pump speed is set in the range between minimum and maximum, the power and pressure are limited when the pump is running on the maximum curve. This means that the maximum performance can be achieved at a speed lower than 100 %. See fig. 26.

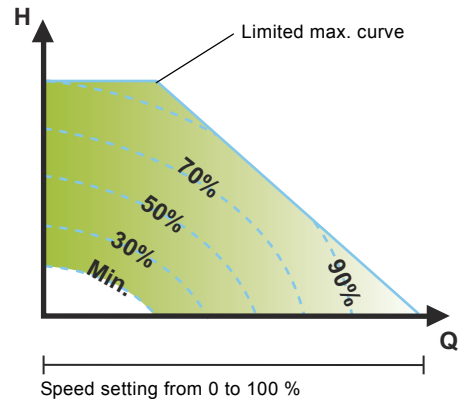

Fig. 26 Power and pressure limitations influencing the maximum curve

You can also set the pump to operate according to the maximum or minimum curve, like an uncontrolled pump:

- You can use the maximum curve mode in periods where a maximum flow is required. This operating mode is for instance suitable for hot-water priority.
- You can use the minimum curve mode in periods where a minimum flow is required. This operating mode is for instance suitable for manual night setback if automatic night setback is not desired.

You can select these two operating modes via the digital inputs.

In the control mode constant curve, you can obtain a constant flow by choosing a setpoint at 100 % and choosing the desired value for the flow rate with the  $FLOW_{LIMIT}$  function. Take the accuracy of the flow estimation into consideration.

## Additional control mode features

MAGNA3 offers additional features for the control modes to meet specific demands.

### FLOW<sub>LIMIT</sub>

The feature is an integrated part of the FLOW<sub>ADAPT</sub> control mode, but is also advantageous in:

- proportional-pressure mode
- constant-pressure mode
- constant-temperature mode
- constant-curve mode.

### Characteristics and key benefits

- A control mode feature that, when activated, ensures that the rated maximum flow is never exceeded.
- By enabling FLOW<sub>LIMIT</sub> in systems where MAGNA3 has full authority, the rated flow is never exceeded, thus eliminating the need for throttling valves.

### Technical specifications

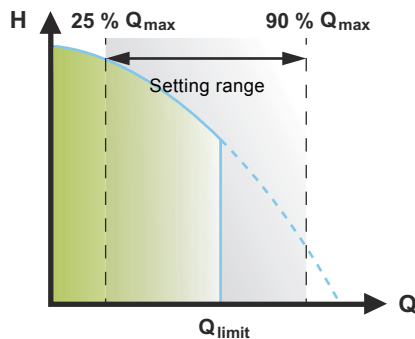

Fig. 27 FLOW<sub>LIMIT</sub>

The setting range for the FLOW<sub>LIMIT</sub> is 25 to 90 % of the  $Q_{max}$  of the pump.

**Note:** Do not set the FLOW<sub>LIMIT</sub> lower than the dimensioned duty point.

In the flow range between 0 and  $Q_{limit}$ , the pump will run according to the selected control mode.

TM05 2445 1312

When  $Q_{limit}$  is reached, the FLOW<sub>LIMIT</sub> function will reduce the pump speed to ensure that the flow never exceeds the FLOW<sub>LIMIT</sub> set, no matter if the system requires a higher flow due to an increased resistance in the system. See figs 28, 29 and 30.

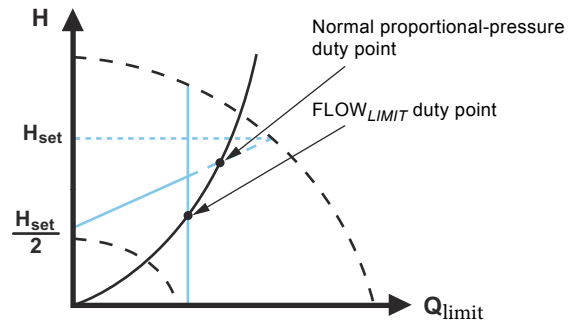

Fig. 28 Proportional-pressure control with FLOW<sub>LIMIT</sub>

TM05 2543 0412

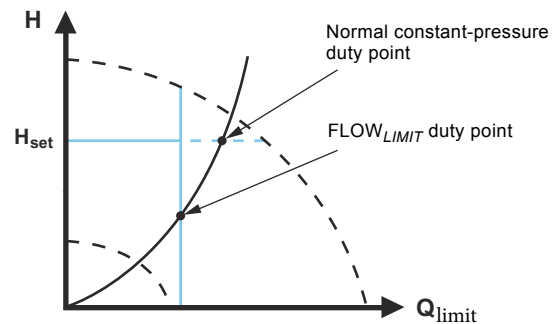

Fig. 29 Constant-pressure control with FLOW<sub>LIMIT</sub>

TM05 2444 0312

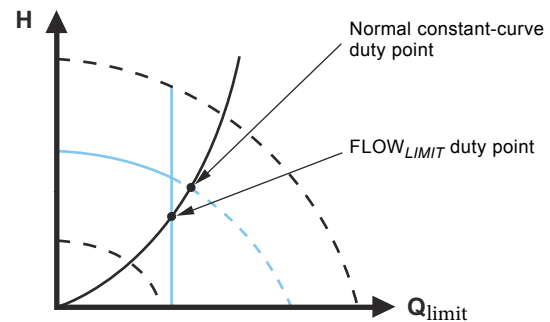

Fig. 30 Constant curve with FLOW<sub>LIMIT</sub>

TM05 2542 0412

## Automatic night setback

A night setback system is often integrated into a building management system (BMS), or as part of an equivalent electronic control system, which has a built-in timer.

The feature is not beneficial in rooms with underfloor heating because of the regulating inertia of the underfloor heating.

### Characteristics and key benefits

- Automatic night setback lowers the room temperature at night, which reduces heating costs.
- The pump automatically changes between normal duty and night setback (duty at low demand), depending on the flow pipe temperature.
- Once activated, the pump runs on the minimum curve.

### Technical specifications

The pump automatically changes to night setback when the built-in sensor registers a flow-pipe temperature drop of more than 18 to 27 °F (10 to 15 °C) within approximately two hours. The temperature drop must be at least 0.18 °F/min (0.1 °C/min).

Changeover to normal duty takes place without time lag when the temperature has increased by approximately 18 °F (10 °C).

**Note:** You cannot enable automatic night setback when the pump is in constant-curve mode.

## Multipump modes

### Multipump function

The multipump function enables control of single-head pumps connected in parallel and twin-head pumps without the use of external controllers. The pumps in a multipump system communicate with each other via the wireless GENIair connection.

Pump system:

- Twin-head pump.
- Two single-head pumps connected in parallel. The pumps must be of equal size and type. Each pump requires a non-return valve in series with the pump.

A multipump system is set via a selected pump, i.e. the master pump (first selected pump). The multipump functions are described in the following sections.

### Alternating operation

Only one pump is operating at a time. The change from one pump to the other depends on time or energy. If a pump fails, the other pump will take over automatically.

### Backup operation

One pump is operating continuously. The backup pump is operated at intervals to prevent seizing up. If the duty pump stops due to a fault, the backup pump will start automatically.

### Cascade operation

Cascade operation ensures that the pump performance is automatically adapted to the consumption by switching pumps on or off. The system thus runs as energy-efficiently as possible with a constant pressure and a limited number of pumps.

The slave pump will start when the master pump is running at maximum or has a fault, and it will stop again when the master pump is running below 50 %.

Cascade operation is available in constant speed and constant pressure. You can with advantage choose a twin-head pump as the backup pump will start for a short period in peak-load situations.

All pumps in operation will run at equal speed. Pump changeover is automatic and depends on speed, operating hours and faults.

## Setting values for control modes

The flow rate values for  $FLOW_{ADAPT}$  and  $FLOW_{LIMIT}$  are indicated in percent of  $Q_{max}$ , but the value has to be entered in  $m^3/h$  in the Settings menu.

$Q_{max}$  is a theoretical value corresponding to  $H = 0$ . The actual  $Q_{max}$  depends on the system characteristics.

The duty ranges for proportional-pressure and constant-pressure control appear from the individual data sheet.

	AUTO <sub>ADAPT</sub> H <sub>fac</sub>	Q <sub>max</sub>	FLOW <sub>ADAPT</sub> / FLOW <sub>LIMIT</sub>		
			Q <sub>fac</sub>	Q <sub>min</sub> 25 %	Q <sub>max</sub> 90 %
			[ft (m)]	[gpm (m <sup>3</sup> /h)]	[gpm (m <sup>3</sup> /h)]
<b>Single-head pump type</b>					
MAGNA3 40-80 F (N)	14.8 (4.5)	94.7 (21.5)	57.2 (13)	23.8 (5.4)	85.4 (19.4)
MAGNA3 40-120 F (N)	21.3 (6.5)	112.2 (25.5)	70.4 (16)	28.2 (6.4)	101.2 (23)
MAGNA3 40-180 F (N)	31.2 (9.5)	125.4 (28.5)	66.0 (15)	31.2 (7.1)	113.1 (25.7)
MAGNA3 50-80 F (N)	14.8 (4.5)	129.8 (29.5)	74.8 (17)	32.6 (7.4)	117.0 (26.6)
MAGNA3 50-150 F (N)	26.2 (8.0)	165.0 (37.5)	88.0 (20)	41.4 (9.4)	148.7 (33.8)
MAGNA3 65-120 F (N)	21.3 (6.5)	209.0 (47.5)	132.0 (30)	52.4 (11.9)	188.3 (42.8)
MAGNA3 65-150 F (N)	26.3 (8.0)	268.6 (61.0)	176.2 (40.0)	67.4 (15.3)	241.8 (54.9)
<b>Twin-head pump type</b>					
MAGNA3 (D) 65-150 F	26.2 (8.0)	248.6 (56.5)	176.0 (40)	62.0 (14.1)	224.0 (50.9)
MAGNA3 (D) 80-100 F	18.0 (5.5)	297.0 (67.5)	206.8 (47)	74.4 (16.9)	267.5 (60.8)
MAGNA3 (D) 100-120 F	21.3 (6.5)	345.4 (78.5)	250.8 (57)	86.2 (19.6)	311.1 (70.7)

Constant curve duty: You can control the pump from minimum to 100 %. The span of control depends on the minimum speed, power and pressure limitation of the pump model.

## Flow estimation accuracy

The internal sensor estimates the difference in pressure between the inlet and outlet port of the pump. The measurement is not a direct differential-pressure measurement, but by knowing the hydraulic design of the pump, you can estimate the differential pressure across the pump. The speed and power are also used to give a direct estimation of the current duty point of the pump.

The calculated flow rate has an accuracy specified as  $\pm xx\%$  of  $Q_{max}$ . The less flow through the pump, the less accurate the reading will be. See also *Heat energy monitor*, page 27.

Example:

1. MAGNA3 65-60 has a  $Q_{max}$  of  $40\ m^3/h$ . A typical 5 % accuracy means  $2\ m^3/h$  inaccuracy of  $Q_{max}$ ,  $\pm 2\ m^3/h$ .
2. This accuracy is valid for the entire QH area. If the pump indicates  $10\ m^3/h$ , the measurement is  $10 \pm 2\ m^3/h$ .
3. The flow rate can be  $8-12\ m^3/h$ .

**Note:** Use of a water and ethylene glycol mixture will decrease the accuracy.

See fig. 31 for flow accuracy calculations of the complete MAGNA3 range.

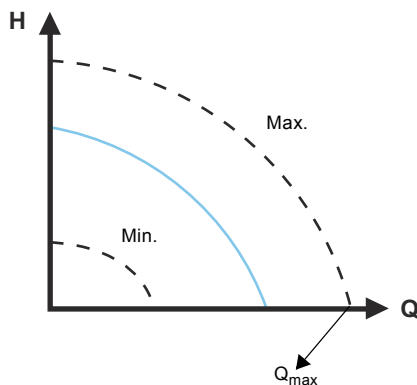

Fig. 31  $Q_{max}$

TM 05 2448 5111



The table below shows the flow accuracy of the complete MAGNA3 range. The calculations are based on a single-head pump at 5 % or 10 % of  $Q_{max}$  or a twin-head pump with a right-side pump head of 7 % or 12 % of  $Q_{max}$ .

	$Q_{max}$	Single-head pumps and left-side pump head of twin-head pumps		Right-side pump head of twin-head pumps	
		5 % typical	10 % worst case	7 % typical	12 % worst case
[gpm (m <sup>3</sup> /h)]					
<b>Single-head pump type</b>					
MAGNA3 40-80 F (N)	96.86 (22)	4.84 (1.1)	9.69 (2.2)	-	-
MAGNA3 40-120 F (N)	127.68 (29)	6.38 (1.45)	12.77 (2.9)	-	-
MAGNA3 40-180 F (N)	140.89 (32)	7.045 (1.6)	14.09 (3.2)	-	-
MAGNA3 50-80 F (N)	136.49 (31)	6.82 (1.55)	13.65 (3.1)	-	-
MAGNA3 50-150 F (N)	184.92 (42)	9.25 (2.1)	18.49 (4.2)	-	-
MAGNA3 65-120 F (N)	209.14 (47.5)	10.48 (2.38)	20.91 (4.75)	-	-
MAGNA3 65-150 F (N)	268.58 (61.00)	13.43 (3.05)	26.86 (6.10)	-	-
<b>Double-head pump type</b>					
MAGNA3 (D) 65-150 F	268.57 (61)	13.43 (3.05)	26.86 (6.1)	18.80 (4.27)	32.23 (7.32)
MAGNA3 (D) 80-100 F	303.80 (69)	15.19 (3.45)	30.38 (6.9)	21.27 (4.83)	36.46 (8.28)
MAGNA3 (D) 100-120 F	374.24 (85)	18.72 (4.25)	37.42 (8.5)	26.20 (5.95)	44.91 (10.20)

## Readings and settings on the pump

### Control panel and display

The MAGNA3 pump features a 4-in. TFT display with intuitive and user-friendly interface. The control panel has self-explanatory push-buttons made of high-quality silicone for precise navigation in the menu structure. The control panel is designed to give the user quick and easy access to pump and performance data on site.

### Startup guide and assistance

When you start up the pump for the first time, you are presented with a startup guide enabling easy setting of the pump. Additionally, the Assist menu can guide you through the various settings of the pump.



Fig. 32 Control panel

Button	Function
	Goes to the Home menu.
	Returns to the previous action.
	Navigates between main menus, displays and digits. When the menu is changed, the display will always show the top display of the new menu.
	Navigates between submenus.
	Saves changed values, resets alarms and expands the value field.

### Setting the pump

The MAGNA3 pump range allows you to set the pump directly on the control panel. The menu includes all available MAGNA3 pump settings such as control mode, setpoint, relay output and bus communication.

## Monitoring the pump

### Performance overview

The home menu allows you to quickly gain an overview of the main settings of up to four user-defined parameters or view a graphical illustration of a QH performance curve.

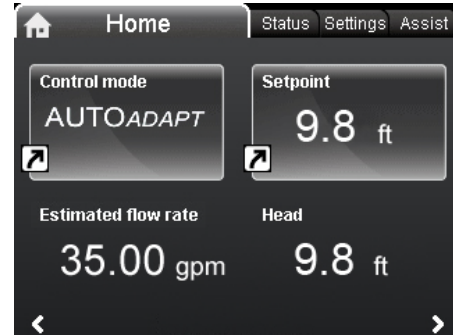

Fig. 33 Example of Home menu with overview of settings and performance

### Operating status and pump performance

The status menu shows the current operating mode and the selected control mode, if any. Here, you can also review the performance of the pump:

- QH graph showing current duty point, flow rate, head, power and liquid temperature.
- "Resulting setpoint" showing the setpoint set on the pump, the external influence and the resulting setpoint.
- Liquid temperature.
- Speed.
- Operating hours.

### Warning and alarm

The Warning and alarm menu provides information on:

- actual warning or alarm, if any
- information about when the warning or alarm occurred, disappeared and about corrective actions
- Warning and alarm logs.

TM05 7642 1313

undef-010\_HOME\_us

## Heat energy monitor

Heat energy monitor is a monitoring function which makes it possible to track the heat energy distribution and consumption within a system. This prevents excessive energy costs caused by system imbalances. The calculated flow rate has an accuracy specified as  $\pm xx\%$  of  $Q_{\max}$ . The lower the flow through the pump is, the less accurate the reading will be. Furthermore, the temperature measurements needed for the calculation is also associated with some inaccuracy, depending on the sensor type. Therefore, you cannot use the heat energy value for billing purposes. However, the value is perfect for optimization purposes in order to prevent excessive energy costs caused by system imbalances. See also *Flow estimation accuracy*, page 24.

The pump requires a temperature sensor in the flow pipe or the return pipe. This temperature sensor is not supplied with the pump.

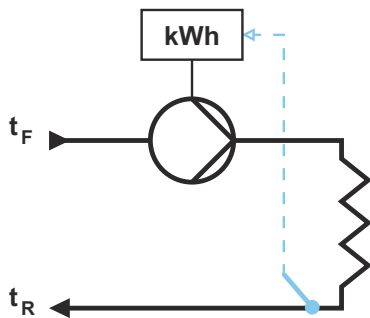

TM05 5367 3612

Fig. 34 MAGNA3 with built-in heat energy monitor

**Note:** MAGNA3 incorporates a calculator for flow and media temperature, see *External Grundfos sensors*, page 58.

## Operating log

The Operating log is the perfect tool for pump optimization, replacement and fault finding as it offers the following:

- All duty points and operating conditions are tracked and stored in the pump.
- The 3D work log and duty curve (over time) provide instant overviews of historical pump performance and operating conditions.

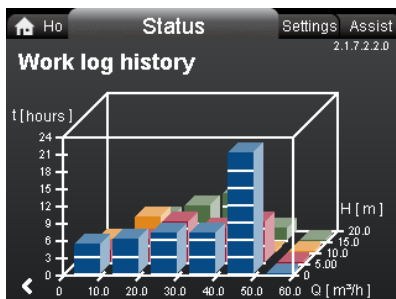

Fig. 35 Example of Operating log

## Help and guidance

The Assist menu guides you through the setup of the pump and offers the following:

- step-by-step instructions in how to set the pump
- a short description of the six control modes and recommended applications
- assistance with fault correction
- fault advice
- multipump setup
- setup, analog input
- description of control mode.

## Grundfos Eye

Grundfos Eye at the top of the control panel is a pump status indicator light providing information about the pump operating status.

The indicator light will flash in different sequences and provide information about the following:

- power on or off
- pump warnings
- pump alarms
- remote control
- pump running or stopped.

The function of Grundfos Eye is described in detail in the installation and operating instructions.



Fig. 36 Grundfos Eye

TM05 3810 1612

## Communication

MAGNA3 enables communication via the following:

- wireless Grundfos GO
- fieldbus communication via CIM modules
- digital inputs
- relay outputs
- analog input.

### Grundfos GO



Fig. 37 Grundfos GO

With Grundfos GO, you can monitor your pump, change settings, collect data and make reports. A user-friendly interface provides you with all the information and help you need, as well as live pump data monitoring and easy-to-follow tips and guides. You can use Grundfos GO for the following functions:

- reading of operating data
- reading of warning and alarm indications
- setting of control mode
- setting of setpoint
- selection of external setpoint signal
- allocation of pump number making it possible to distinguish between pumps that are connected via Grundfos GENIbus
- selection of function for digital input
- generation of reports (PDF)
- assist function
- multipump setup
- displaying relevant documentation.

For further details, see *Grundfos GO*, page 57.

### Wireless GENIair

The pump is designed for multipump connection via the wireless GENIair connection.

The built-in wireless GENIair module enables communication between pumps and with Grundfos GO without the use of add-on modules:

- Multipump function.  
See *Multipump function*, page 23.
- Grundfos GO.  
See *Grundfos GO*, page 57.

### CIM modules

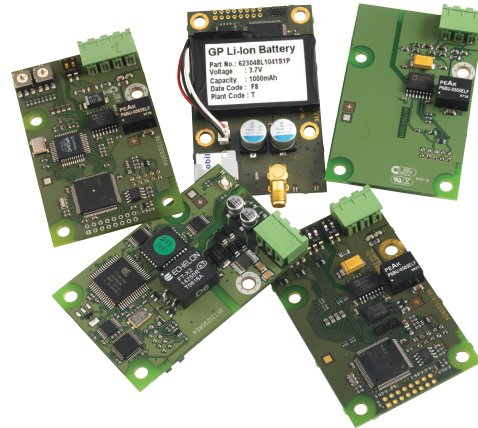
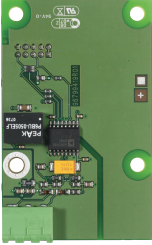
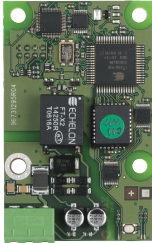







Fig. 38 Grundfos CIM modules

A CIM module is an add-on Communication Interface Module. The CIM module enables data transmission between the pump and an external system, for example a BMS (Building Management System) or SCADA system.

The CIM module communicates via fieldbus protocols. See *Available CIM modules*, page 29.

## Available CIM modules

Module	Fieldbus protocol	Description	Functions
<p><b>CIM 050</b></p> 	<p>GENIBus</p> <p>TM06 7238 3416</p>	<p>CIM 050 is a Grundfos communication interface module used for communication with a GENIBus network.</p>	<p>CIM 050 has terminals for the GENIBus connection.</p>
<p><b>CIM 100</b></p> 	<p>LonWorks</p> <p>TM06 7279 3416</p>	<p>CIM 100 is a Grundfos communication interface module used for communication with a LonWorks network.</p>	<p>CIM 100 has terminals for the LonWorks connection.</p> <p>Two LEDs are used to indicate the actual status of the CIM 100 communication.</p> <p>One LED is used for indication of correct connection to the pump, and the other is used to indicate LonWorks communication status.</p>
<p><b>CIM 150</b></p> 	<p>PROFIBUS DP</p> <p>TM06 7280 3416</p>	<p>CIM 150 is a Grundfos communication interface module used for communication with a PROFIBUS network.</p>	<p>CIM 150 has terminals for the PROFIBUS DP connection.</p> <p>DIP switches are used to set line termination.</p> <p>Two hexadecimal rotary switches are used to set the PROFIBUS DP address.</p> <p>Two LEDs are used to indicate the actual status of the CIM 150 communication module.</p> <p>One LED is used for indication of correct connection to the pump, and the other is used to indicate PROFIBUS communication status.</p>
<p><b>CIM 200</b></p> 	<p>Modbus RTU</p> <p>TM06 7281 3416</p>	<p>CIM 200 is a Grundfos communication interface module used for communication with a Modbus RTU network.</p>	<p>CIM 200 has terminals for the Modbus connection.</p> <p>DIP switches are used to select parity and stop bits, to select transmission speed and to set line termination.</p> <p>Two hexadecimal rotary switches are used to set the Modbus address.</p> <p>Two LEDs are used to indicate the actual status of the CIM 200 communication.</p> <p>One LED is used for indication of correct connection to the pump, and the other is used to indicate Modbus communication status.</p>
<p><b>CIM 250</b></p> 	<p>GSM/GPRS</p> <p>TM06 7282 3416</p>	<p>CIM 250 is a Grundfos communication interface module used for GSM/GPRS communication.</p> <p>CIM 250 is used to communicate via a GSM network.</p>	<p>CIM 250 has a SIM card slot and an SMA connection to the GSM antenna.</p> <p>CIM 250 also has an internal backup battery. Two LEDs are used to indicate the actual status of the CIM 250 communication. One LED is used for indication of correct connection to the pump, and the other is used to indicate GSM/GPRS communication status.</p> <p><b>Note:</b> The SIM card is not supplied with CIM 250. The SIM card from the service provider must support data service to use call service from PC Tool or SCADA. The SIM card from the service provider must support GPRS service to use Ethernet service from PC Tool or SCADA.</p>

Module	Fieldbus protocol	Description	Functions
<p><b>CIM 270</b></p>  <p>GP Li-Ion Battery Part No: 62304E104191P Voltage : 3.7V Capacity : 1000mAh Data Code : F8 Print Code : T</p>	<p>Grundfos Remote Management</p> <p>TM06 7282 3416</p>	<p>CIM 270 is a Grundfos GSM/GPRS modem used for communication with a Grundfos Remote Management system. CIM 270 requires a GSM antenna, a SIM card and a contract with Grundfos.</p>	<p>With CIM 270, you have wireless access to your account anywhere, anytime when you have an internet connection, for example via a smartphone, tablet PC, laptop or computer. Warnings and alarms can be sent by e-mail or SMS to your mobile phone or computer. You will get a complete status overview of the entire GRM system. The status overview allows you to plan maintenance and service based on actual operating data.</p>
<p><b>CIM 300</b></p> 	<p>BACnet MS/TP</p> <p>TM06 7281 3416</p>	<p>CIM 300 is a Grundfos communication interface module used for communication with a BACnet MS/TP network.</p>	<p>CIM 300 has terminals for the BACnet MS/TP connection. DIP switches are used to set transmission speed and line termination and to select the custom Device Object Instance Number. Two hexadecimal rotary switches are used to set the BACnet address. Two LEDs are used to indicate the actual status of the CIM 300 communication. One LED is used for indication of correct connection to the pump, and the other is used to indicate BACnet communication status.</p>
<p><b>CIM 500</b></p> 	<p>Ethernet</p> <p>TM06 7283 3416</p>	<p>CIM 500 is a Grundfos communication interface module used for data transmission between an industrial Ethernet network and a Grundfos product. CIM 500 supports various industrial Ethernet protocols:</p> <ul style="list-style-type: none"> <li>• PROFINET</li> <li>• Modbus TCP</li> <li>• BACnet/IP</li> <li>• Ethernet/IP</li> </ul>	<p>CIM 500 supports various industrial Ethernet protocols. CIM 500 is configured via the built-in web server, using a standard web browser on a PC. See the specific functional profile on the DVD-ROM supplied with the Grundfos CIM module.</p>

For product numbers, see *CIM modules*, page 56.

### Grundfos Remote Management

Grundfos Remote Management is an easy-to-install, low-cost solution for wireless monitoring and management of Grundfos products. GRM is based on a centrally hosted database and a web server with wireless data collection via GSM/GPRS modem. The system only requires an internet connection, a web browser, a GRM modem and an antenna as well as a contract with Grundfos allowing you to monitor and manage Grundfos pump systems.

You have wireless access to your account anywhere and anytime you have an internet connection, for example via a smartphone, tablet PC, laptop or computer. Warnings and alarms can be sent by email or SMS to your mobile phone or computer.

For information about the CIM communication interface module and GSM antennas, see page 28.

### Digital inputs

You can use the digital input for external control of start or stop or forced maximum or minimum curve.

**Note:** If no external on and off switch is connected, maintain the jumper between the Start/Stop (S/S) and frame ( $\perp$ ) terminals. This connection is the factory setting.

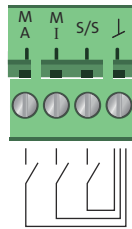

Fig. 39 Digital input in control box

TM05 3343 1212

Contact symbol	Function
M A	Maximum curve
M I	Minimum curve
S/S	Start/Stop
$\perp$	Frame connection

### External start or stop

You can start and stop the pump via the digital input.

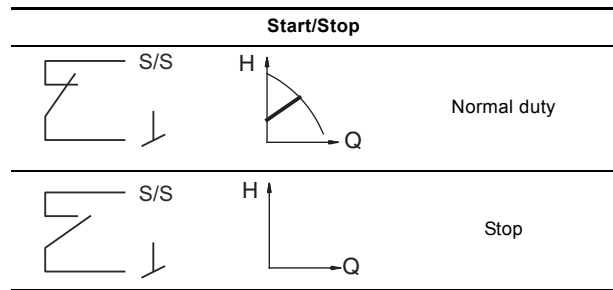

### External forced maximum or minimum curve

You can force the pump to operate on the maximum or minimum curve via the digital input.

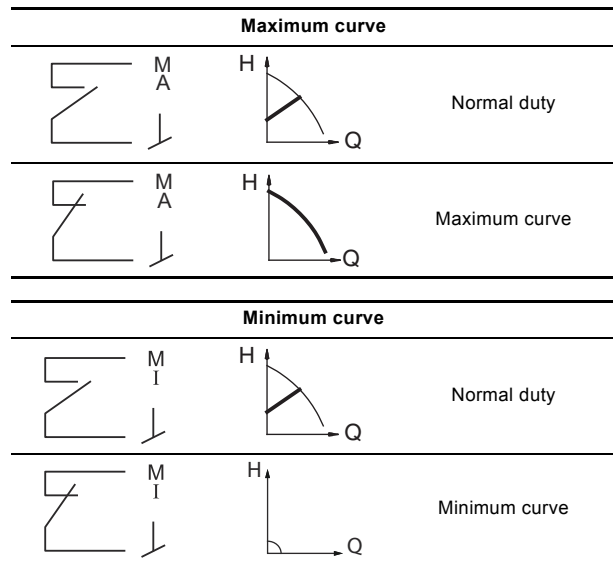

## Relay outputs

The pump has two signal relays with a potential-free changeover contact for external fault indication.

You can set the function of the signal relay to Alarm, Ready or Operation on the pump control panel or with Grundfos GO.

Factory settings of relays:

Relay	Function
1	Operation signal
2	Alarm signal

**Note:** You can configure both relays to "ready, alarm or operating".

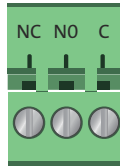

TM05 3343 1212

**Fig. 40** Relay output in the control box

Contact symbol	Function
NC	Normally closed
NO	Normally open
C	Common

The functions of the signal relays are as shown in the table below:

### Signal relay Alarm signal



Not activated:

- The power supply has been switched off.
- The pump has not registered a fault.



Activated:

- The pump has registered a fault.

### Signal relay Ready signal



Not activated:

- The pump has registered a fault and is unable to run.



Activated:

- The pump has been set to stop, but is ready to run.
- The pump is running.

### Signal relay Operating signal



Not activated:

- The pump is not running.



Activated:

- The pump is running.

## Analog input for an external sensor

To optimize pump performance, you can use the analog input for the connection of an external sensor in the following cases:

Function/control mode	Sensor type
Heat energy monitor	Temperature sensor
Constant temperature	
Constant pressure	Differential-pressure transmitter

When using an external differential-pressure sensor to control the flow in the system, you obtain the externally set pressure, which results in the following benefits:

- minimizes operating costs
- prevents valve noise
- ensures comfort (adequate pressure).

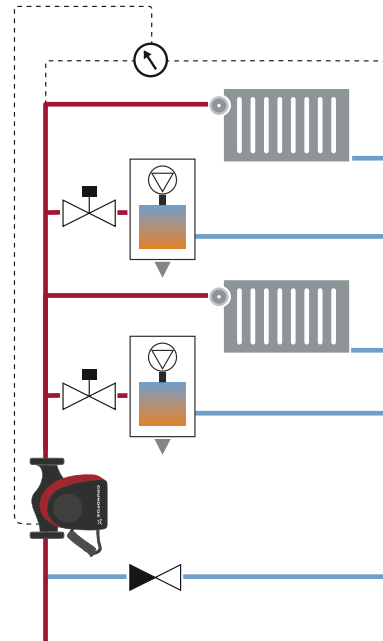

**Fig. 41** External differential-pressure sensor

TM06 3255 5014



The electrical signal for the input can be 0-10 V or 4-20 mA. You can change the selection of the electrical signal (0-10 V or 4-20 mA) on the control panel or with Grundfos GO.

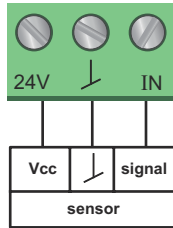

Fig. 42 Analog input for an external sensor or control

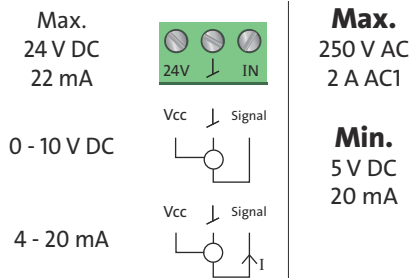

Fig. 43 Wiring, analog input

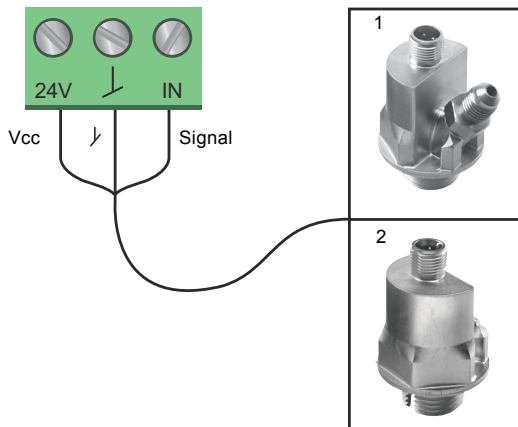

Fig. 44 Examples of external sensors

Pos.	Sensor type
1	Differential-pressure transmitter, Grundfos type DPI V.2 1/2" connection and 4-20 mA signal.
2	Relative-pressure transmitter. Combined temperature and pressure sensor, Grundfos type RPI T2. 1/2" connection and 0-10 V signal.

For further details, see *External Grundfos sensors*, page 58.

**External control system**

The analog input can be used for an external signal for the control from a BMS system or similar control system.

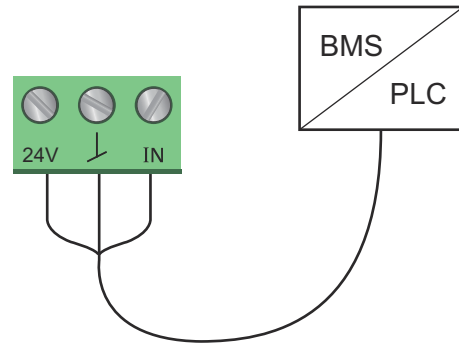

Fig. 45 Example of an external signal for the control via BMS or PLC

**External setpoint function**

You can use the analog input to influence the setpoint externally. Here, a 0-10 V or 4-20 mA signal controls the pump speed range in a linear function. The range of control depends on the minimum speed, power and pressure limits of the pump. See figs 46 and 47.

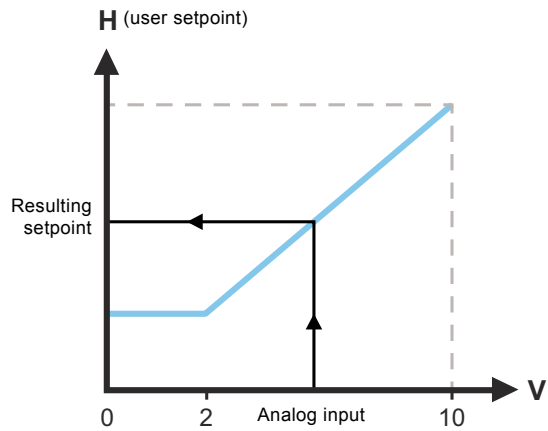

Fig. 46 External setpoint function, 0-10 V

Control	
0-2 V (0-20 %)	Resulting setpoint is equal to minimum.
2-10 V (20-100 %)	Resulting setpoint is between minimum and user setpoint.

Fig. 47 Control range and setpoint

The external setpoint function operates differently, depending on the model. For model A,B and C, the maximum speed is often obtained at voltages lower than 10 V as the span of control is limited.

In models newer than A,B, and C, the internal scaling has been optimized to make the dynamic area bigger, thus giving a better control of the pump speed when using the external setpoint function.

The same applies if the pump is receiving a setpoint from Building Management Systems.

## 5. Operating conditions

### General recommendations

<b>Water in heating systems</b>	Water quality according to local standards such as the German standard VDI 2035
<b>Domestic hot water</b>	Degree of hardness up to 14 °dH
<b>Water containing glycol</b>	Maximum viscosity = 10-50 cSt ~ 50 % water and 50 % ethylene glycol at +14 °F (-10 °C)

### Liquid temperature

Application	Temperature range
General	+14 to +230 °F (-10 to +110 °C)
Domestic hot-water systems	Up to 149 °F (65 °C) recommended

### Ambient conditions

Ambient conditions	
Ambient temperature during operation	32 to 104 °F (0 to 40 °C)
Ambient temperature during storage and transport	-40 to 158 °F (-40 to +70 °C)
Relative humidity	Maximum 95 %

### Maximum operating pressure

PN 12: 175 psi (12 bar, 1.2 MPa).

### Minimum inlet pressure

The following relative minimum pressure must be available at the pump inlet during operation to avoid cavitation noise and damage to the pump bearings. The values in the table below apply to single-head pumps and twin-head pumps in single-head operation.

MAGNA3 DN	Liquid temperature		
	[167 °F (75 °C)]	[203 °F (95 °C)]	[230 °F (110 °C)]
Inlet pressure [psi (bar)]			
40-80/120/180	1.45 (0.10)	7.25 (0.50)	14.50 (1.00)
50-80	1.45 (0.10)	5.80 (0.40)	14.50 (1.00)
50-150	10.15 (0.70)	17.40 (1.20)	24.66 (1.70)
65-120/150	10.15 (0.70)	17.40 (1.20)	24.66 (1.70)
80-100	7.25 (0.50)	14.50 (1.00)	21.76 (1.50)
100-120	10.15 (0.70)	17.40 (1.20)	24.66 (1.70)

In the case of cascade twin-head operation, increase the required relative inlet pressure by 1.45 psi (0.1 bar, 0.01 MPa) compared to the stated values for single-head pumps or twin-head pumps in single-head operation.

**Note:** The actual inlet pressure plus pump pressure against a closed valve must be lower than the maximum permissible system pressure.

The relative minimum inlet pressures apply to pumps installed up to 984 ft (300 meters) above sea level. For altitudes above 984 ft (300 meters), increase the required relative inlet pressure by 0.145 psi (0.01 bar, 0.001 MPa) per 328 ft (100 meters) altitude. The MAGNA3 pump is only approved for an altitude of 6560 ft (2000 meters).

### Pumped liquids

The pump is suitable for thin, clean, non-aggressive and non-explosive liquids, not containing solid particles or fibers that may attack the pump mechanically or chemically.

In heating systems, the water must meet the requirements of accepted standards on water quality in heating systems.

In domestic hot-water systems, we recommend that you use MAGNA3 pumps only for water with a degree of hardness lower than approximately 14 °dH.

In domestic hot-water systems, we recommend that you keep the liquid temperature below 149 °F (65 °C) to eliminate the risk of lime precipitation.

You can use MAGNA3 pumps for pumping water and glycol mixtures up to 50 %.

Example of a water and ethylene glycol mixture:

Maximum viscosity: 10-50 cSt ~ 50 % water and 50 % ethylene glycol mixture at +14 °F (10 °C).

The pump is controlled by a power-limiting function that protects against overload.

The pumping of glycol mixtures will affect the maximum curve and reduce the performance, depending on the water and ethylene glycol mixture and the liquid temperature.

To prevent the ethylene glycol mixture from degrading, avoid temperatures exceeding the rated liquid temperature and minimize the operating time at high temperatures.

You must clean and flush the system before the ethylene glycol mixture is added.

To prevent corrosion or lime precipitation, maintain the ethylene glycol mixture regularly. If further dilution of the supplied ethylene glycol is required, follow the glycol supplier's instructions.

## Electrical data

<b>Pump type</b>	<b>MAGNA3 (D)</b>
<b>Enclosure class</b>	IPX4D (EN 60529).
<b>Insulation class</b>	F.
<b>Supply voltage</b>	1 x 115 V ± 10 %, 60 Hz*, PE. 1 x 230 V ± 10 %, 60 Hz*, PE. M20 cable gland (supplied with the pump).
<b>Three digital inputs</b>	External potential-free contact. Contact load: 5 V, 10 mA. Screened cable. M16 cable gland (not supplied with the pump). Loop resistance: Maximum 130 Ω.
<b>Analog input</b>	4-20 mA (load: 150 Ω). 0-10 VDC (load: > 10 kΩ). M16 cable gland (not supplied with the pump).
<b>Two relay outputs</b>	Internal potential-free changeover contact. Maximum load: 250 V, 2 A, AC1. Minimum load: 5 VDC, 20 mA. Screened cable, depending on signal level. M16 cable gland (not supplied with the pump).
<b>Bus input</b>	Grundfos Communication Interface Modules (add-on CIM modules) for: <ul style="list-style-type: none"> <li>• GENibus</li> <li>• LonWorks</li> <li>• PROFIBUS DP</li> <li>• Modbus RTU</li> <li>• GSM/GPRS</li> <li>• Grundfos Remote Management</li> <li>• BACnet MS/TP</li> <li>• Ethernet.</li> </ul>
<b>Leakage current</b>	$I_{leakage} < 3.5 \text{ mA}$ . The leakage currents are measured in accordance with EN 60335-1.
<b>EMC</b>	Standards used: EN 55014-1:2006+A1:2009+A2:2011, EN 55014-2:1997+A1:2001+A2:2008, EN 61000-3-2:2006+A1:2009+A2:2009, EN 61000-3-3:2013.
<b>Cos φ</b>	Terminal-connected versions have a built-in active PFC (Power Factor Control) which gives a cos φ from 0.98 to 0.99, i.e. very close to 1. Plug-connected versions have no PFC and therefore the power factor is from 0.50 to 0.99.
<b>Consumption when the pump is stopped</b>	4 to 10 W, depending on activity, i.e. reading the display, use of Grundfos GO, interaction with modules, etc. 4 W, when the pump is stopped and there is no activity.

\* All MAGNA3 pumps are approved to run on both 50 and 60 Hz.

## Sound pressure level

<b>Pump type</b>	<b>MAGNA3 (D)</b>
<b>Sound pressure level</b>	≤ 43 dB(A)

## 6. Construction

MAGNA3 is of the canned-rotor type, i.e. the pump and motor form an integral unit without shaft seal and with only two gaskets for sealing. The bearings are lubricated by the pumped liquid.

The pump is characterized by the following:

- controller integrated in the control box
- control panel on the control box
- control box prepared for optional CIM modules
- built-in differential-pressure and temperature sensor
- cast-iron or stainless-steel pump housing
- twin-head versions
- no external motor protection required
- insulating shells supplied with single-head pumps for heating systems.

### Motor and electronic controller

MAGNA3 incorporates a 4-pole synchronous, permanent-magnet motor (PM motor). This motor type is characterized by higher efficiency than a conventional asynchronous squirrel-cage motor.

The pump speed is controlled by an integrated variable frequency drive.

### Differential-pressure and temperature sensor

The differential-pressure and temperature sensor is located in the pump housing in a channel between the inlet and outlet ports.

Via a cable, the sensor sends an electrical signal for the differential pressure across the pump and for the liquid temperature to the controller in the control box.

The sensor offers substantial benefits:

- direct feedback on the pump display
- complete pump control
- measurement of the pump workload for precise and optimum control resulting in higher energy efficiency.

### Sensor specifications, temperature

Temperature range during operation	Accuracy
+14 to +95 °F (-10 to +35 °C)	± 7 °F (± 4 °C)
+95 to +194 °F (+35 to +90 °C)	± 3.5 °F (± 2 °C)
+194 to +230 °F (+90 to +110 °C)	± 7 °F (± 4 °C)

### Surface treatment

The pump housing and pump head are electrocoated to improve corrosion resistance.

Electrocoating includes:

- alkaline cleaning
- pretreatment with zinc phosphate coating
- cathodic electrocoating (epoxy)
- curing of paint film at 392 to 482 °F (200 to 250 °C).

The pump housing of stainless-steel versions is not treated or painted and appears in blank steel. See fig. 48.



Fig. 48 MAGNA3 stainless steel version

### Color

Color codes for the pump:

Color	Code
Red	NCS40-50R
Black	NCS9000

TM06 0139 4913 - TM06 0140 4913

## Sectional drawing

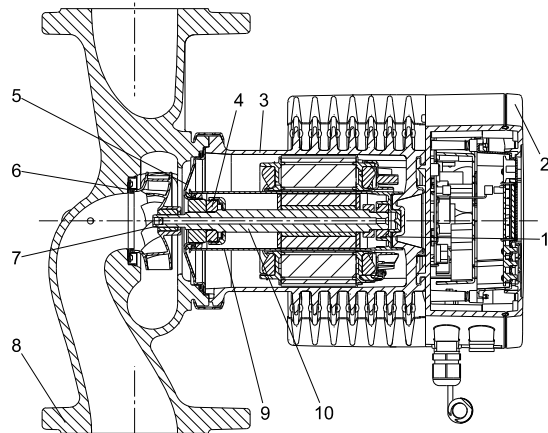

TM05 2319 0312

Fig. 49 Terminal-connected version

## Material specification

See fig. 49.

Pos.	Component	Material	Grade
1	Outer bearing ring	Aluminium oxide	
2	Control box	Polycarbonate	
3	Stator housing	Aluminium	
	O-rings	EPDM	
4	Thrust bearing	Aluminium oxide/carbon	
5	Bearing plate	Stainless steel	AISI 304 (EN 1.4301)
6	Neck ring	Stainless steel	AISI 304 (EN 1.4301)
7	Impeller	PES	
8	Pump housing	Cast iron/stainless steel	ASTM A48 class 35B/AISI 316 (EN 1561 EN-GJL-250/EN 1.4408)
9	Rotor can	PPS	
10	Shaft	Ceramic (plug-connected versions)	
10	Shaft	Stainless steel (terminal-connected versions)	AISI 316L (EN 1.4404)

## Sensor drawing

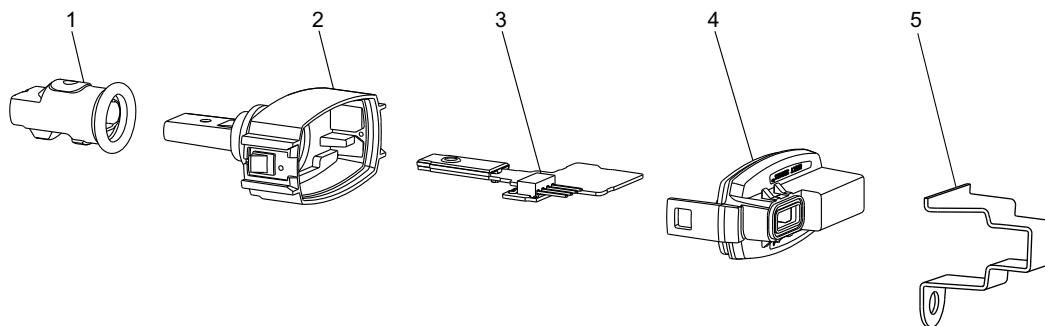

TM06 9250

Fig. 50 Sensor

Pos.	Component	Material	Grade
1	Sealing cap	EPDM	
2	Housing	PPS	
3	Printed-circuit board	-	
4	Cover snap-on	PA/TPV	
5	Bracket for sensor	Stainless steel	AISI 304 (EN 1.4301)

## 7. Installation

### Mechanical installation

MAGNA3 is designed for indoor installation. You must install the pump with horizontal motor shaft. You can install the pump in horizontal as well as vertical pipes.

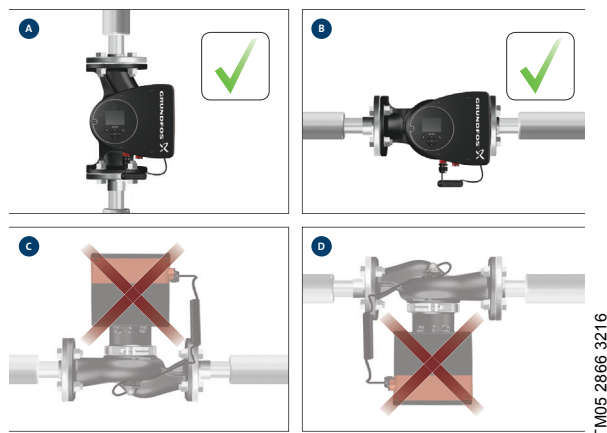

**Fig. 51** Installation positions

Arrows on the pump housing indicate the liquid flow direction through the pump.

The control box must be in horizontal position with the Grundfos logo in vertical position. See fig. 51.

You must install the pump in such a way that it is not stressed by the pipes.

The pump may be suspended directly in the pipes, provided that the pipes can support the pump.

Twin-head pumps are prepared for installation on a mounting bracket or base plate.

To ensure adequate cooling of motor and electronics, observe the following:

- Position the pump in such a way that sufficient cooling is ensured.
- The temperature of the ambient air must not exceed 104 °F ° (40 °C).

### Insulating shells

The insulating shells supplied with single-head MAGNA3 pumps are for heating systems and must be fitted as part of the installation. **Note:** Insulating shells are not available for twin-head pumps.

### Electrical installation

The electrical connection and protection must be carried out in accordance with local regulations.

- The pump must be connected to an external main switch.
- The pump must always be correctly grounded.
- The pump requires no external motor protection.
- The pump incorporates thermal protection against slow overloading and blocking.
- When switched on via the power supply, the pump will start pumping after approximately 5 seconds.

**Note:** The number of starts and stops via the power supply must not exceed four times per hour.

The pump has a digital input that you can use for external control of start/stop without switching the power supply on and off.

Make the pump mains connection as shown in the diagrams on the following pages.

If rigid conduit is to be used, the hub must be connected to the conduit system before it is connected to the terminal box of the pump.

### Cables

Use screened cables for the external on and off switch, the digital input, sensor and setpoint signals.

All cables used must be heat-resistant up to at least 75 °C.

All cables used must be installed in accordance with the National Electrical Code, or in Canada, Canadian Electrical Code, and state and local regulations.

### Additional protection

If national legislation requires a Ground Fault Circuit Interrupter (GFCI) or equivalent in the electrical installation, this must be type B (according to UL/IEC 61800-5-1) or better, due to the nature of the constant DC leakage current.

## Connection to power supply, terminal-connected versions

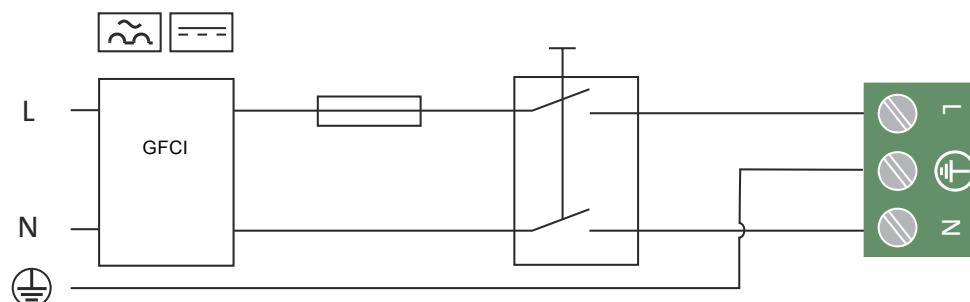

Fig. 52 Example of a terminal-connected motor with main switch, backup fuse and additional protection

TM03 2397 3216

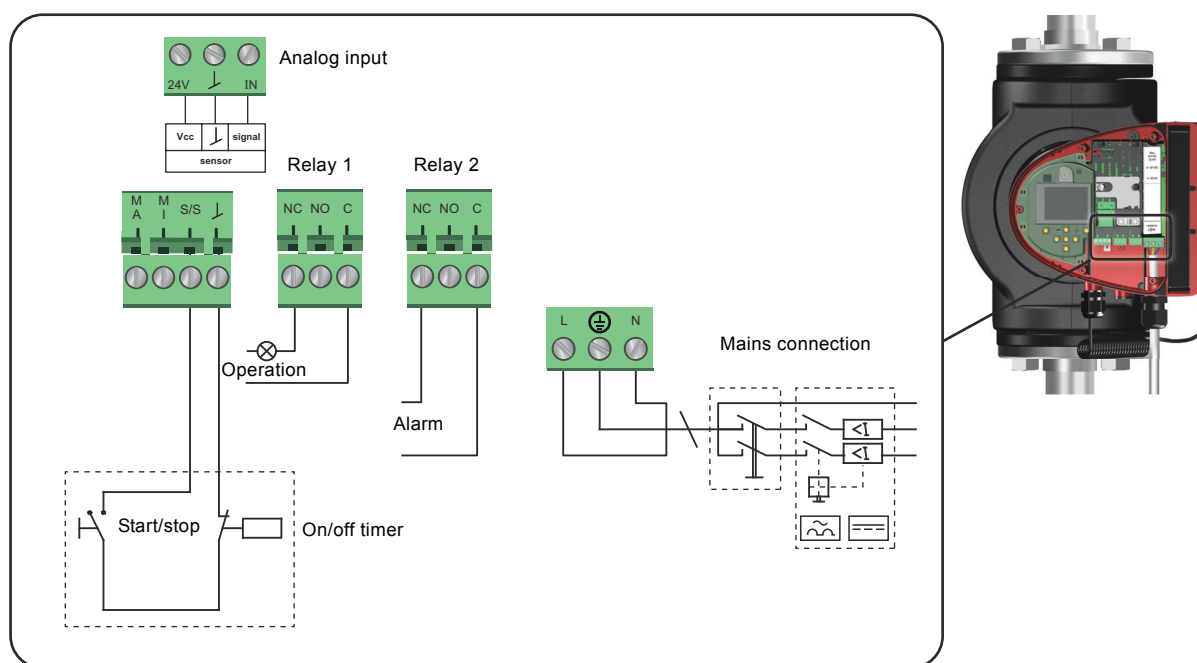

Fig. 53 Example of connections in the control box of terminal-connected versions

TM05 2673 2017

For further information on digital and analog inputs, see *Digital inputs*, page 31, and *Analog input for an external sensor*, page 32.

For information on relay outputs, see *Relay outputs*, page 32.

For details on how to install and operate the MAGNA3 pumps, please see the MAGNA3 model D - Installation and operating instructions:



[net.grundfos.com/qr/i/99332342](http://net.grundfos.com/qr/i/99332342)



## 8. Curve conditions

### Performance curves

The guidelines below apply to the performance curves on pages 43 to 55:

- Test liquid: airless water.
- The curves apply to a density of  $\rho = 983.2 \text{ kg/m}^3$  and a liquid temperature of 140 °F (60 °C).
- All curves show average values. If a specific minimum performance is required, individual measurements must be made.
- The curves apply to a kinematic viscosity of  $\mu = 0.474 \text{ mm}^2/\text{s}$  (0.474 cSt).
- Reference supply voltage: 1 x 230 V, 50 Hz.
- EEI obtained according to EN 16297.

**Note:** Within the MAGNA3 performance range, you can set the constant- and proportional-pressure curves in steps of 0.1 m head on the control panel or with Grundfos GO.

### Energy efficiency index (EEI)

MAGNA3 is energy-optimized and complies with the EuP Directive (Commission Regulation (EC) No 641/2009) which has been effective as from 1 January 2013.

For MAGNA3 pumps, the average energy efficiency index (EEI) is 0.18 with values down to 0.17, categorized as best in class.

MAGNA3 with its AUTO<sub>ADAPT</sub> function is the preferred choice for large heating systems and a true efficiency frontrunner.

Figure 54 shows the energy consumption index for a typical circulator pump compared to the various EEI limits.

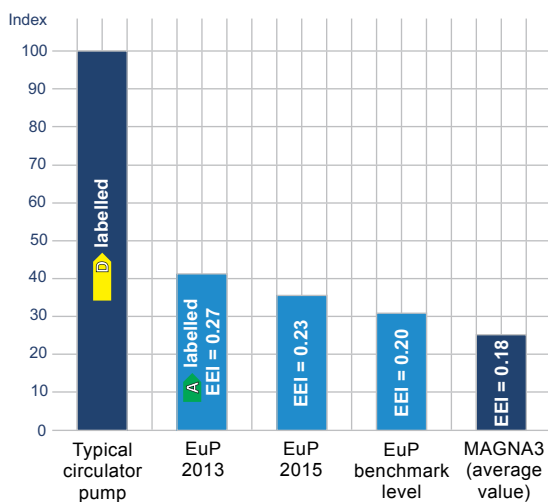

Fig. 54 Energy consumption index, single pumps

With an energy efficiency index (EEI) well below the EuP benchmark level, you can achieve energy savings of up to 75 % compared to a typical circulator pump and thus a remarkably fast return on investment.

### QR code on the pump nameplate



TM05 3826 2017

Fig. 55 QR code on the pump nameplate



With Grundfos GO or a smartphone, you get the following information about MAGNA3:

- product photo
- pump performance curves
- dimensional sketches
- wiring diagram
- quotation text
- technical data
- service parts list
- PDF files, such as data booklet and installation and operating instructions.

TM05 3935 1712

## Markings and approvals

The following marks are available after positive testing of MAGNA3:

Mark	Description
 <p>ETL Listed c US Intertek</p>	<p>Intertek - ETL Listed for USA and Canada</p> <p>Conforms to      ANSI/UL Std. 778      Motor Operated Water Pumps</p> <p>Certified to      CAN/CSA C22.2 No. 108      Liquid Pumps</p>
 <p>CLASSIFIED c UL US NSF/ANSI 372</p>	<p>USA and Canada</p> <p>Applies to pumps with stainless steel pump housing (flange).</p>

## 9. Performance curves and technical data

Conversion tables:

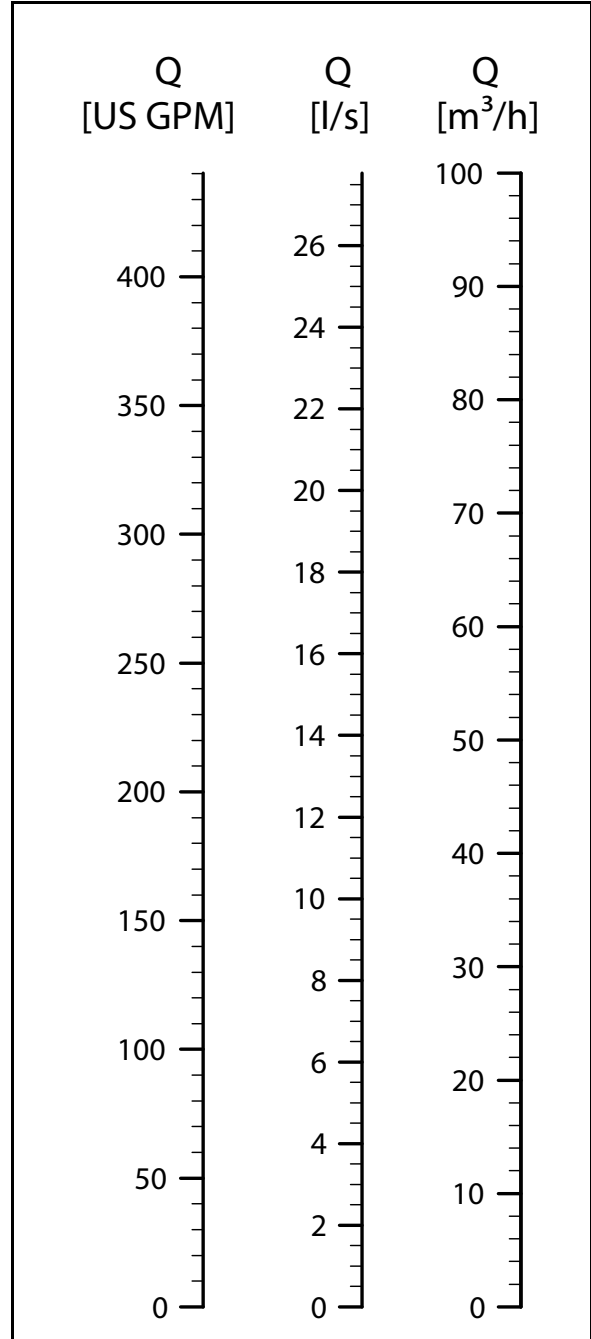
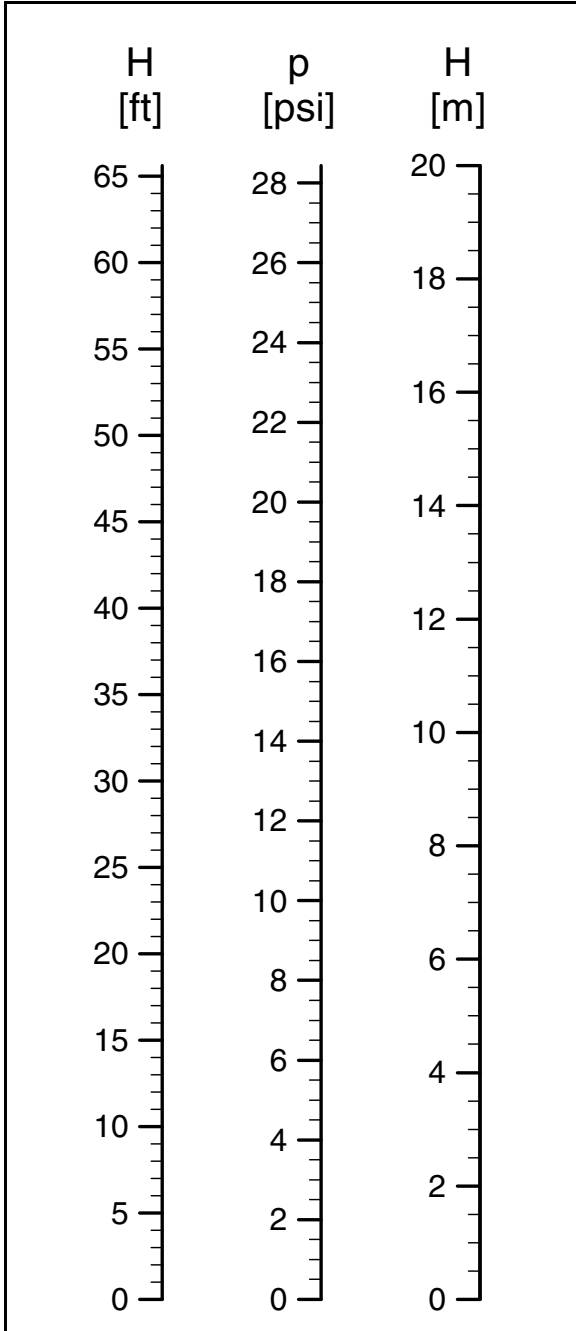

MAGNA3 40-80 F (N)

1 x 115, 230 V, 60 Hz

Proportional pressure

Constant pressure

0-10 volts\*

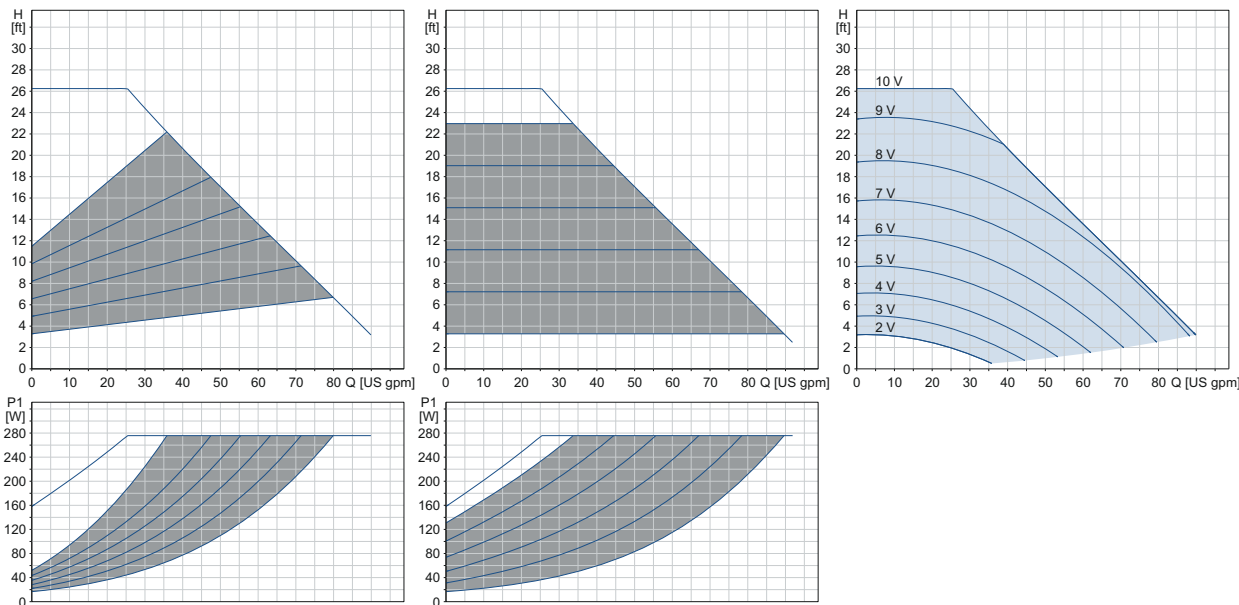

Speed	P1 [W] 115 V	I <sub>1</sub> [A] 115 V	P1 [W] 230 V	I <sub>1</sub> [A] 230 V
Min.	16	0.30	16	0.19
Max.	290	2.57	290	1.33

The pump incorporates overload protection.

Net weights [lb (kg)]	Gross weights [lb (kg)]	Ship. vol. [ft <sup>3</sup> (m <sup>3</sup> )]
36.4 (16.5)	40.2 (18.2)	1.42 (0.04)

\* External setpoint influence shown with a setpoint of H<sub>max</sub>

- Connections: GF15/26/40/43 flanges. See *Pipe connections*, page 60.
- System pressure: Max. 175 psi (1.2 MPa) (12 bar).
- Liquid temperature: 14 to 230 °F (-10 to +110 °C) (TF 110).
- Also available with: Stainless-steel pump housing, type N.
- Specific EEI: 0.20 (115 V)  
0.19 (230 V)

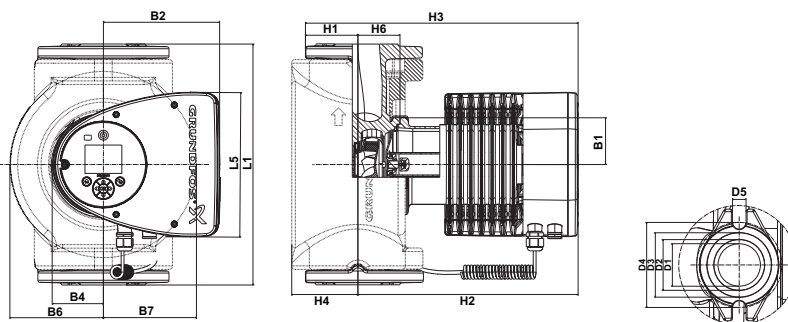

TM05 7651 1413

Pump type	Dimensions [in (mm)]								
	L1	L5	B1	B2	B4	B6	B7	D1	D2
MAGNA3 40-80 F (N)	8.5 (216)	8.03 (204)	3.31 (84)	6.46 (164)	2.87 (73)	4.37 (111)	4.37 (111)	1.57 (40)	1.93 (49)
	D3	D4	D5	H1	H2	H3	H4	H6	
	2.4 (60)	3.15 (80)	0.5 (12.8)	1.46 (37)	11.97 (304)	13.3 (338)	2.76 (70)	1.97 (50)	

For product numbers, see page 61.

MAGNA3 40-120 F (N)

1 x 115, 230 V, 60 Hz

Proportional pressure

Constant pressure

0-10 volts\*

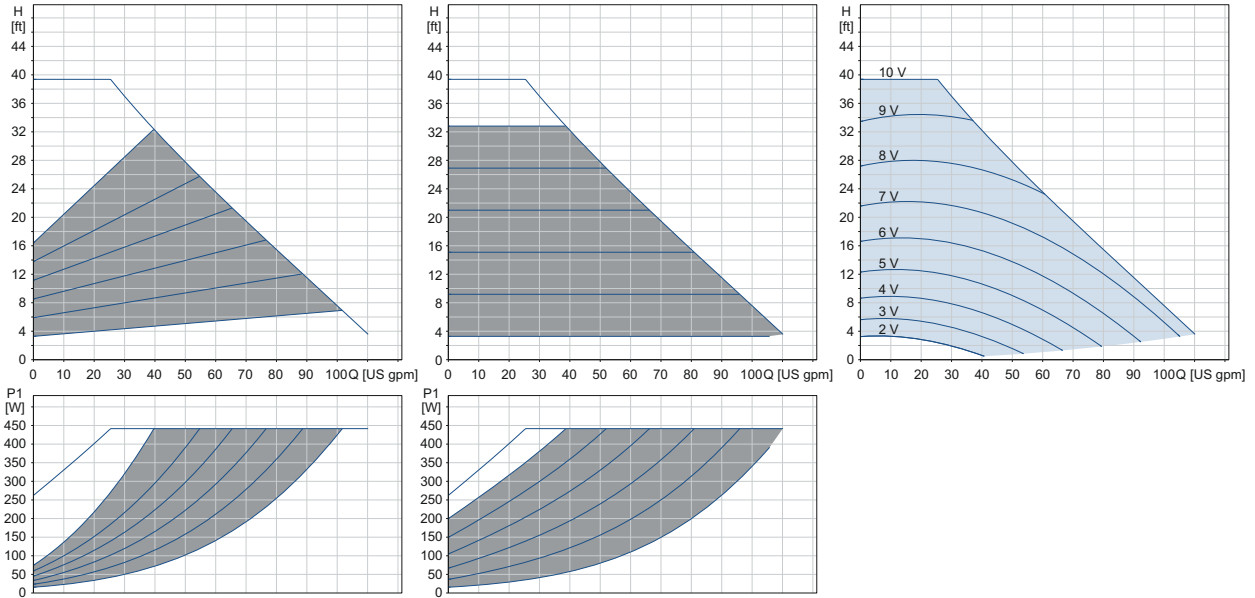

Speed	P1 [W] 115 V	I <sub>1</sub> [A] 115 V	P1 [W] 230 V	I <sub>1</sub> [A] 230 V
Min.	16	0.26	16	0.19
Max.	450	3.96	450	2.00

\* External setpoint influence shown with a setpoint of H<sub>max</sub>

The pump incorporates overload protection.

Net weights [lb (kg)]	Gross weights [lb (kg)]	Ship. vol. [ft <sup>3</sup> (m <sup>3</sup> )]
35.8 (16.2)	38.9 (17.6)	1.42 (0.04)

- Connections: GF15/26/40/43 flanges. See *Pipe connections*, page 60.
- System pressure: Max. 175 psi (1.2 MPa) (12 bar).
- Liquid temperature: 14 to 230 °F (-10 to +110 °C) (TF 110).
- Also available with: Stainless-steel pump housing, type N.
- Specific EEI: 0.19 (115V)  
0.19 (230V)

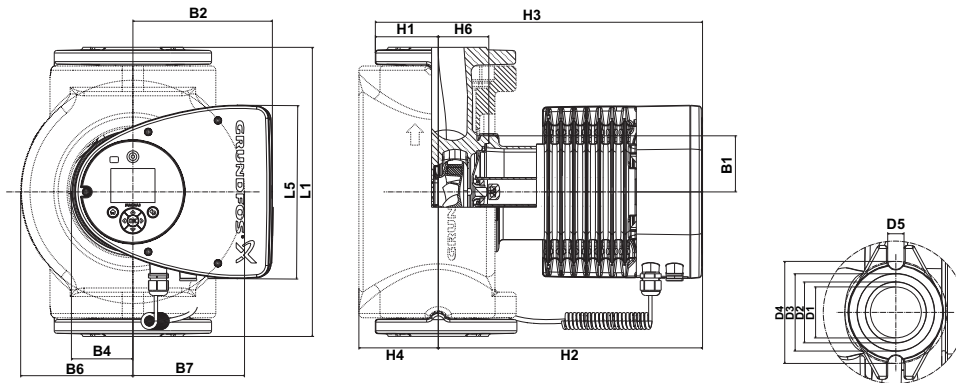

TM05 7651 1413

Pump type	Dimensions [in (mm)]								
	L1	L5	B1	B2	B4	B6	B7	D1	D2
MAGNA3 40-120 F (N)	8.5 (216)	8.03 (204)	3.31 (84)	6.46 (164)	2.87 (73)	4.37 (111)	4.37 (111)	1.57 (40)	1.93 (49)
	D3	D4	D5	H1	H2	H3	H4	H6	
	2.4 (60)	3.15 (80)	0.5 (12.8)	1.46 (37)	11.97 (304)	13.3 (338)	2.76 (70)	1.97 (50)	

For product numbers, see page 61.

MAGNA3 40-180 F (N)

1 x 115, 230 V, 60 Hz

Proportional pressure

Constant pressure

0-10 volts\*

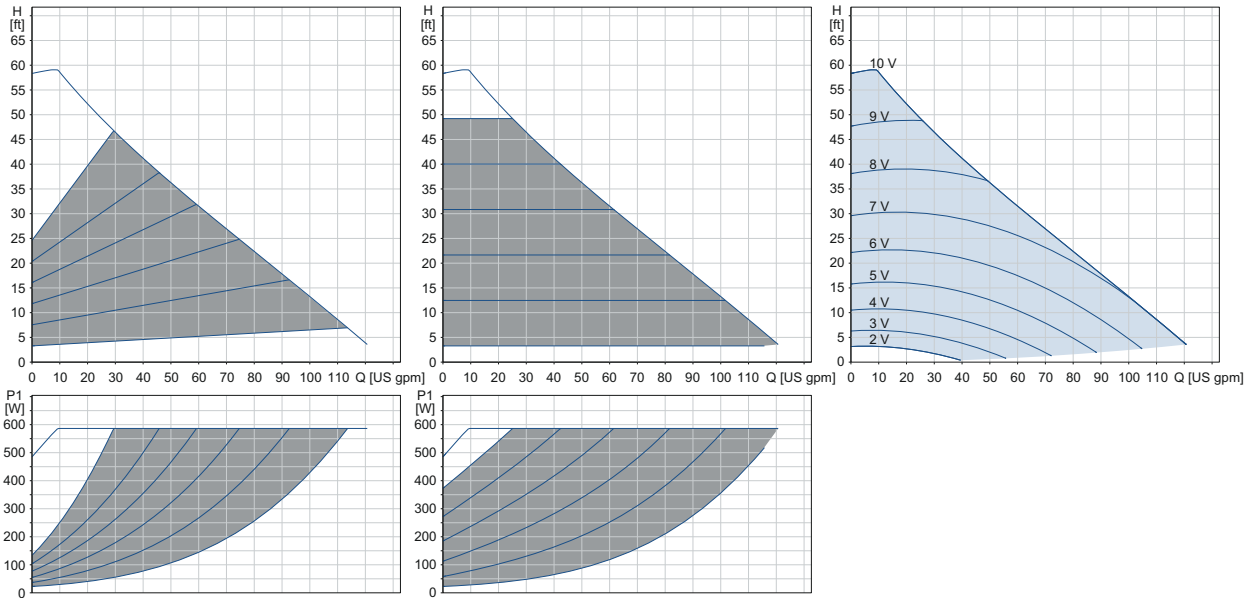

Speed	P1 [W] 115 V	I <sub>1</sub> [A] 115 V	P1 [W] 230 V	I <sub>1</sub> [A] 230 V
Min.	16	0.26	16	0.18
Max.	600	5.26	600	2.65

\* External setpoint influence shown with a setpoint of H<sub>max</sub>

The pump incorporates overload protection.

Net weights [lb (kg)]	Gross weights [lb (kg)]	Ship. vol. [ft <sup>3</sup> (m <sup>3</sup> )]
35.8 (16.2)	38.9 (17.6)	1.42 (0.04)

Connections: GF15/26/40/43 flanges. See *Pipe connections*, page 60.  
 System pressure: Max. 175 psi (1.2 MPa) (12 bar).  
 Liquid temperature: 14 to 230 °F (-10 to +110 °C) (TF 110).  
 Also available with: Stainless-steel pump housing, type N.  
 Specific EEI: 0.18 (115V) / 0.19 (230V)

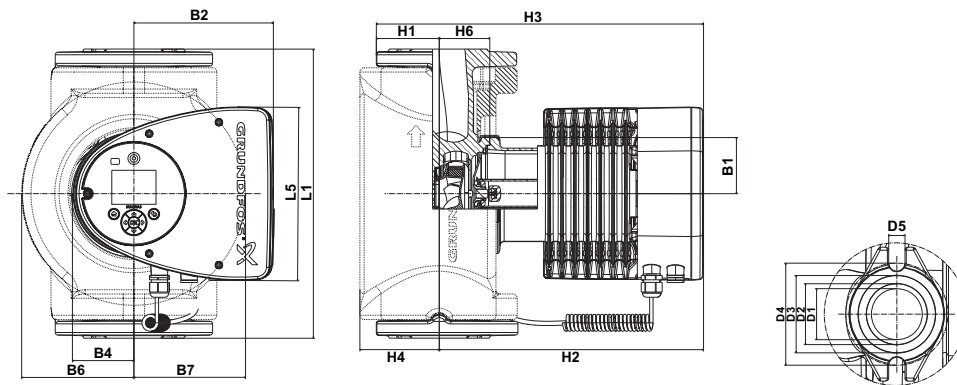

TM05 7651 1413

Pump type	Dimensions [in (mm)]								
	L1	L5	B1	B2	B4	B6	B7	D1	D2
MAGNA3 40-180 F (N)	8.5 (216)	8.03 (204)	3.31 (84)	6.46 (164)	2.87 (73)	4.37 (111)	4.37 (111)	1.57 (40)	1.93 (49)
	2.4 (61)	3.15 (80)	0.5 (12.8)	1.46 (37)	11.97 (304)	13.3 (338)	2.76 (70)	1.97 (50)	

For product numbers, see page 61.

MAGNA3 50-80 F (N)

1 x 115, 230 V, 60 Hz

Proportional pressure

Constant pressure

0-10 volts\*

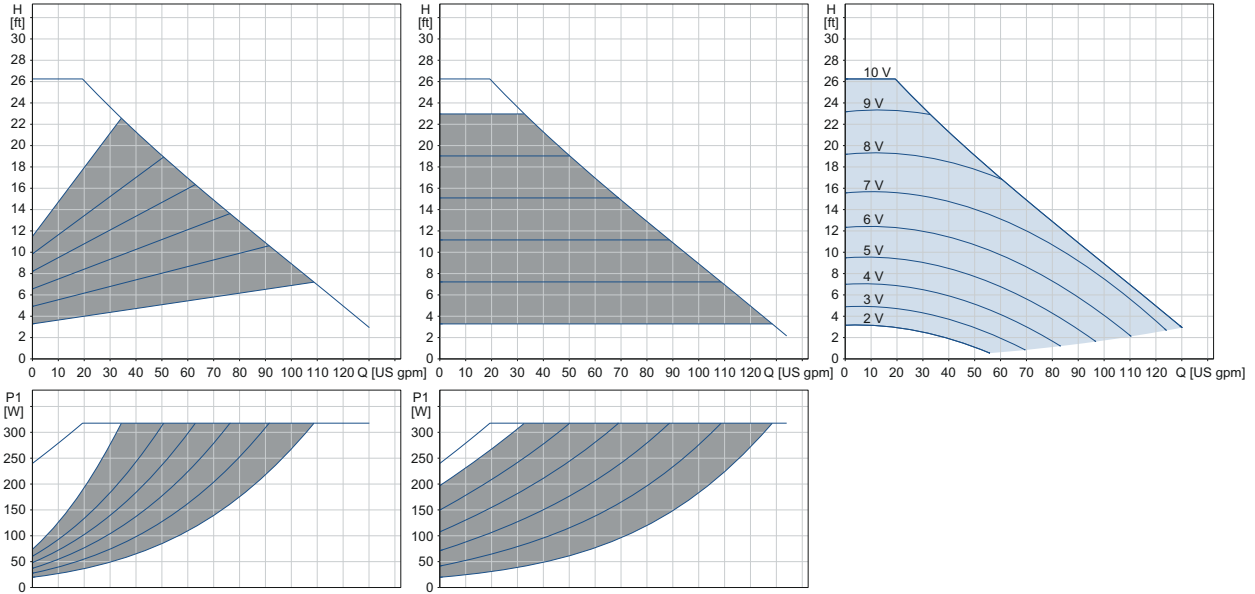

Speed	P1 [W] 115 V	I <sub>1</sub> [A] 115 V	P1 [W] 230 V	I <sub>1</sub> [A] 230 V
Min.	18.5	0.31	18.5	0.22
Max.	350	3.09	350	1.58

\* External setpoint influence shown with a setpoint of H<sub>max</sub>

The pump incorporates overload protection.

Net weights [lb (kg)]	Gross weights [lb (kg)]	Ship. vol. [ft <sup>3</sup> (m <sup>3</sup> )]
39.3 (17.8)	43.5 (19.7)	1.77 (0.05)

Connections:

GF53 flanges.  
See *Pipe connections*, page 60.

System pressure:

Max. 175 psi (1.2 MPa) (12 bar).

Liquid temperature:

14 to 230 °F (-10 to +110 °C) (TF 110).

Also available with:

Stainless-steel pump housing, type N.

Specific EEI:

0.19 (115V)

0.18 (230V)

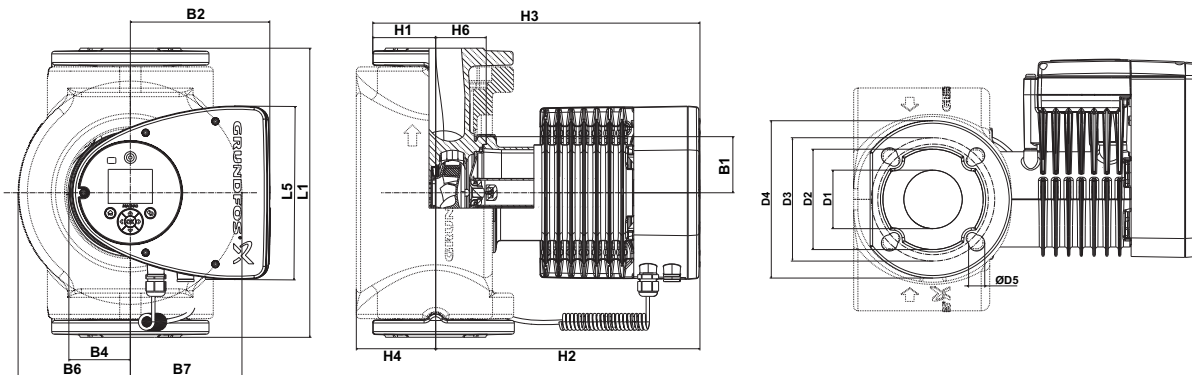

TM05 7652 1413

Pump type	Dimensions [in (mm)]								
	L1	L5	B1	B2	B4	B6	B7	D1	D2
MAGNA3 50-80 F (N)	9.45 (240)	8.03 (204)	3.31 (84)	6.46 (164)	2.87 (73)	5 (127)	5 (127)	1.97 (50)	3.90 (99)
	D3	D4	D5	H1	H2	H3	H4	H6	
	4.33/4.92 (110/125)	6.5 (165)	0.55/0.75 (14/19)	2.8 (71)	12.05 (306)	14.84 (377)	3.82 (97)	2.05 (52)	

For product numbers, see page 61.

MAGNA3 50-150 F (N)

1 x 115, 230 V, 60 Hz

Proportional pressure

Constant pressure

0-10 volts\*

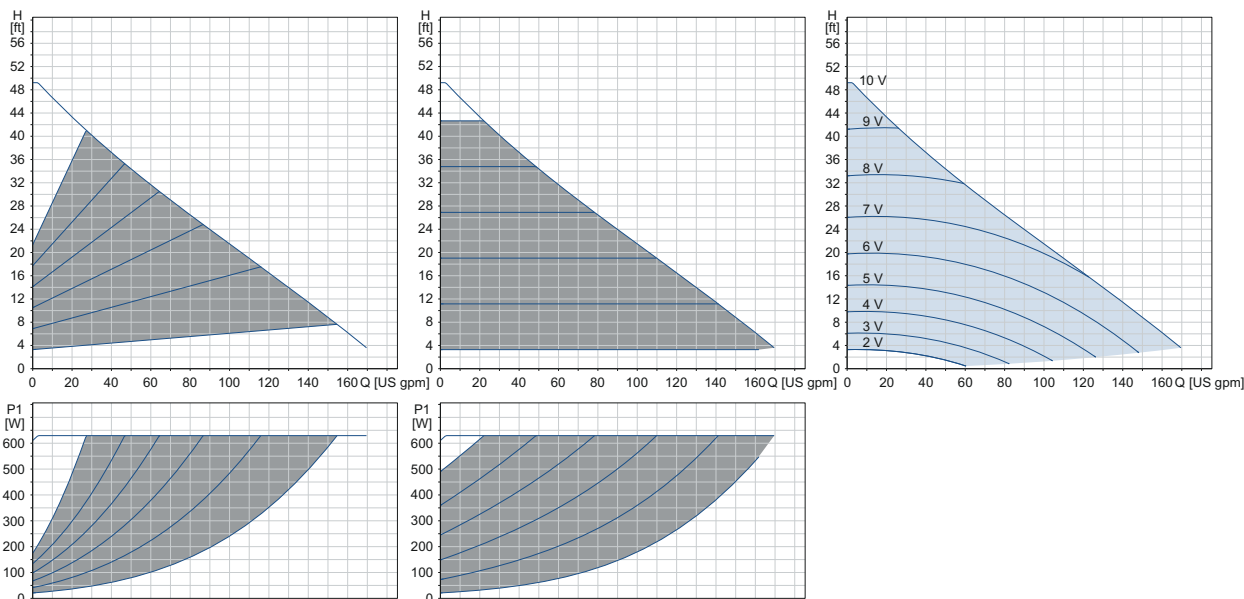

Speed	P1 [W] 115 V	I <sub>1</sub> [A] 115 V	P1 [W] 230 V	I <sub>1</sub> [A] 230 V
Min.	18.5	0.31	18.5	0.23
Max.	650	5.69	650	2.87

\* External setpoint influence shown with a setpoint of H<sub>max</sub>

The pump incorporates overload protection.

Net weights [lb (kg)]	Gross weights [lb (kg)]	Ship. vol. [ft <sup>3</sup> (m <sup>3</sup> )]
42.2 (19.1)	47.0 (21.3)	1.77 (0.05)

Connections: GF53 flanges. See *Pipe connections*, page 60.  
 System pressure: Max. 175 psi (1.2 MPa) (12 bar).  
 Liquid temperature: 14 to 230 °F (-10 to +110 °C) (TF 110).  
 Also available with: Stainless-steel pump housing, type N.  
 Specific EEI: 0.18 (115V) / 0.17(230V)

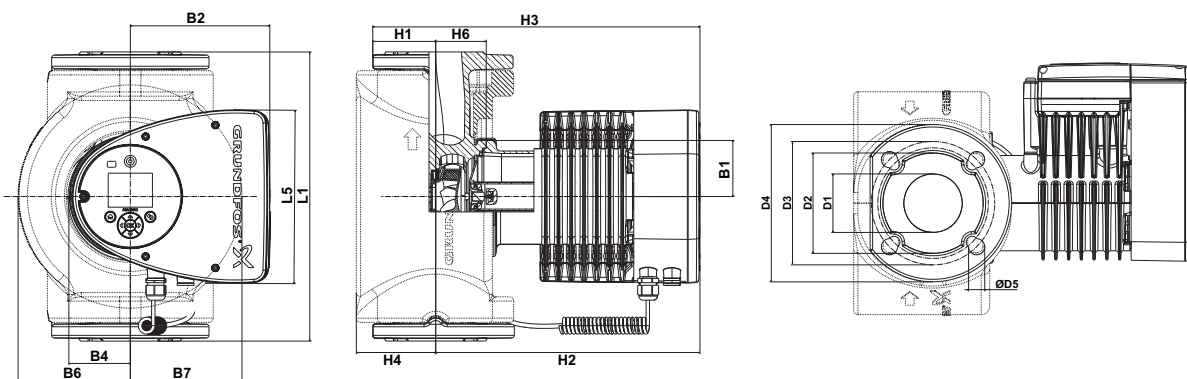

TM05 7652 1413

Pump type	Dimensions [in (mm)]									
	L1	L5	B1	B2	B4	B6	B7	D1	D2	
MAGNA3 50-150 F (N)	11.02 (280)	8.03 (204)	3.31 (84)	6.46 (164)	2.87 (73)	5 (127)	5 (127)	1.97 (50)	3.90 (99)	
	D3	D4	D5	H1	H2	H3	H4	H6		
	4.33/4.92 (110/125)	6.5 (165)	0.55/0.75 (14/19)	2.83 (72)	12.05 (306)	14.9 (378)	3.82 (97)	2.05 (52)		

For product numbers, see page 61.



MAGNA3 65-120 F (N)

1 x 115, 230 V, 60 Hz

Proportional pressure

Constant pressure

0-10 volts\*

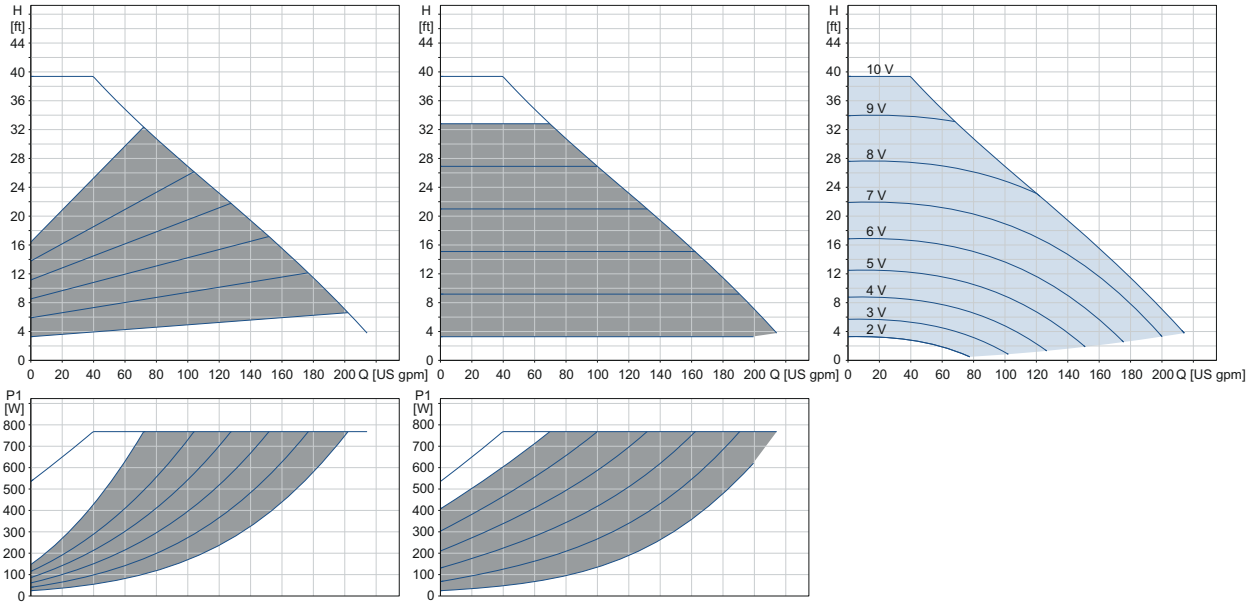

Speed	P1 [W] 115 V	I <sub>1</sub> [A] 115 V	P1 [W] 230 V	I <sub>1</sub> [A] 230 V
Min.	20.5	0.36	0.18	20.5
Max.	750	6.75	750	3.32

\* External setpoint influence shown with a setpoint of H<sub>max</sub>

The pump incorporates overload protection.

Net weights [lb (kg)]	Gross weights [lb (kg)]	Ship. vol. [ft <sup>3</sup> (m <sup>3</sup> )]
47.4 (21.5)	52.5 (23.8)	2.12 (0.06)

- Connections: GF53/65 flanges. See *Pipe connections*, page 60.
- System pressure: Max. 175 psi (1.2 MPa) (12 bar).
- Liquid temperature: 14 to 230 °F (-10 to +110 °C) (TF 110).
- Also available with: Stainless-steel pump housing, type N.
- Specific EEI: 0.17 (115V), 0.17 (230V)

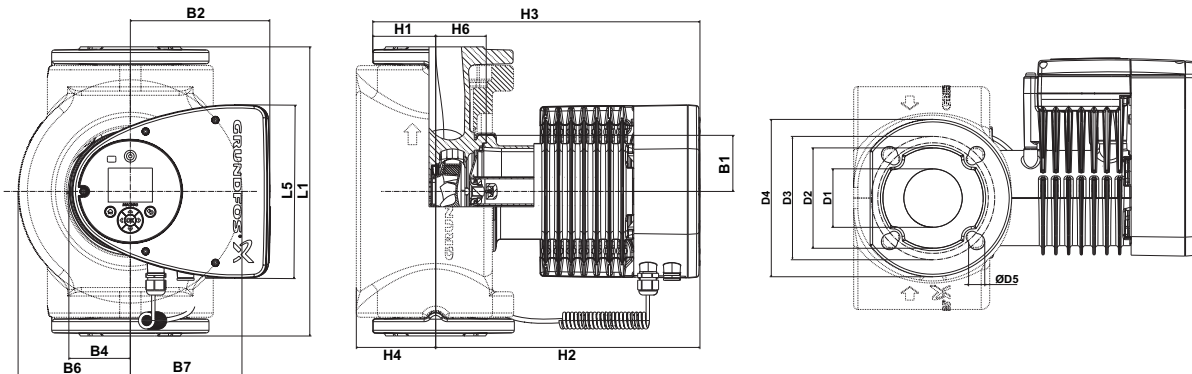

TM05 7652 1413

Pump type	Dimensions [in (mm)]								
	L1	L5	B1	B2	B4	B6	B7	D1	D2
MAGNA3 65-120 F (N)	13.4 (340)	8.03 (204)	3.31 (84)	6.46 (164)	2.87 (73)	5.24 (133)	5.24 (133)	2.56 (65)	4.65 (118)
	D3	D4	D5	H1	H2	H3	H4	H6	
	5.0/5.51 (127/140)	7.28 (185)	0.63/0.75 (16/19)	2.91 (74)	12.28 (312)	15.2 (386)	3.7 (94)	2.32 (59)	

For product numbers, see page 61.

MAGNA3 65-150 F (N)

1 x 230 V, 60 Hz

Proportional pressure

Constant pressure

0-10 volts\*

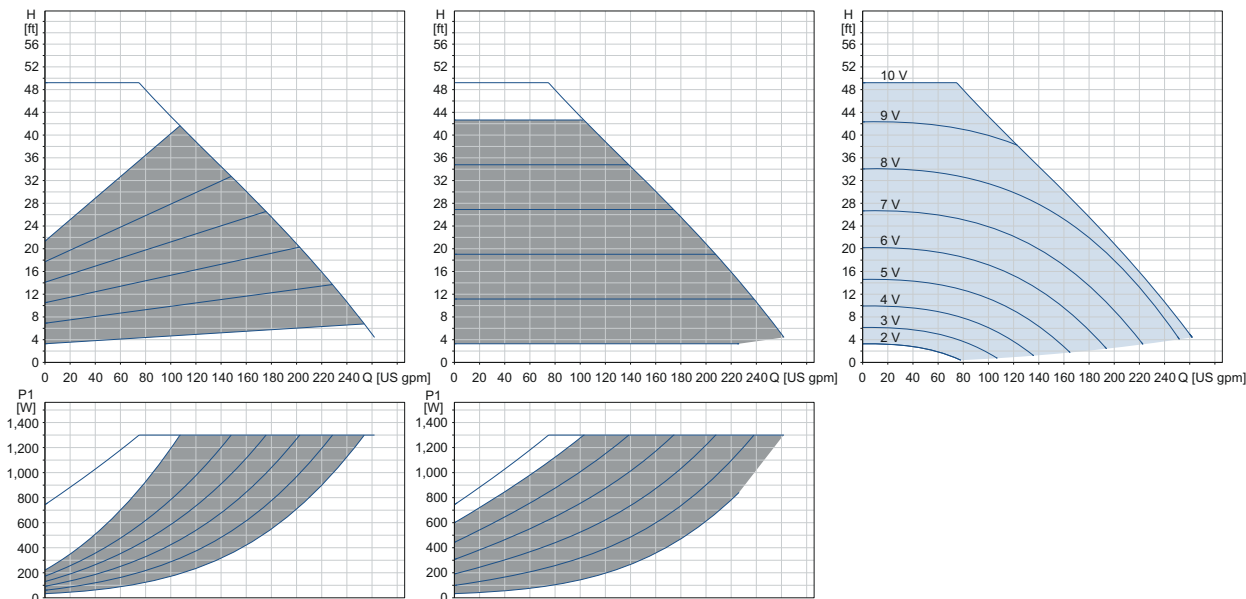

Speed	P1 [W] 230 V	I <sub>1</sub> [A] 230 V
Min.	31	0.32
Max.	1380	6.10

The pump incorporates overload protection.

Net weights [lb (kg)]	Gross weights [lb (kg)]	Ship. vol. [ft <sup>3</sup> (m <sup>3</sup> )]
66.2 (30.0)	71.9 (32.6)	2.12 (0.06)

\* External setpoint influence shown with a setpoint of H<sub>max</sub>

Connections:

GF65 flanges.  
See *Pipe connections*, page 60.

System pressure:

Max. 175 psi (1.2 MPa) (12 bar).

Liquid temperature:

14 to 230 °F (-10 to +110 °C) (TF 110).

Also available with:

Stainless-steel pump housing, type N.

Specific EEI:

0.17.

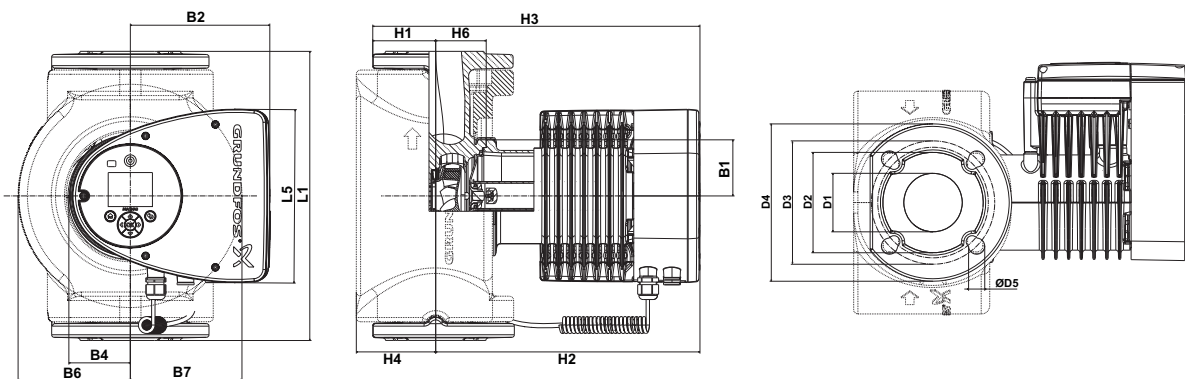

TMM05 7652 1413

Pump type	Dimensions [in (mm)]								
	L1	L5	B1	B2	B4	B6	B7	D1	D2
MAGNA3 65-150 F (N)	13.4 (340)	8.03 (204)	3.31 (84)	6.46 (164)	2.87 (73)	5.24 (133)	5.24 (133)	2.56 (65)	4.65 (118)
	D3	D4	D5	H1	H2	H3	H4	H6	
	5.0/5.51 (127/140)	7.28 (185)	0.63/0.75 (16/19)	2.91 (74)	12.28 (312)	15.2 (386)	3.7 (94)	2.32 (59)	

For product numbers, see page 61.

MAGNA3 D 65-150 F

1 x 230 V, 60 Hz

Proportional pressure

Constant pressure

0-10 volt\*

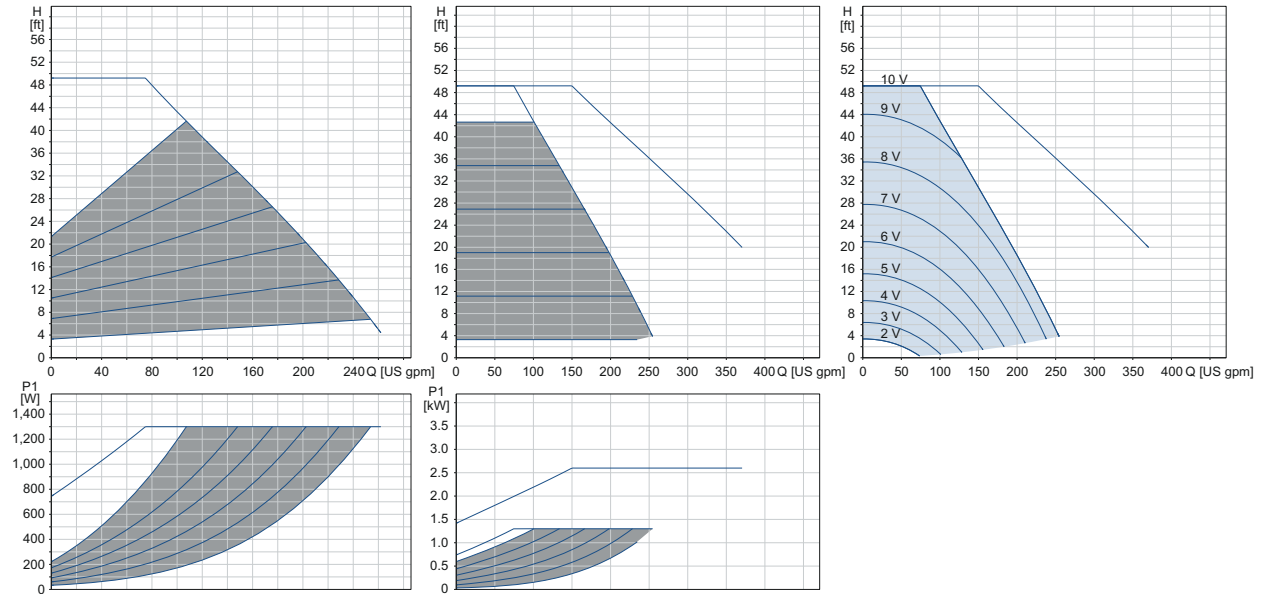

Speed	P1 [W] 230 V	I <sub>1</sub> [A] 230 V
Min.	29	0.30
Max.	1410	6.18

The pump incorporates overload protection.

Net weights [lb (kg)]	Gross weights [lb (kg)]	Ship. vol. [ft <sup>3</sup> (m <sup>3</sup> )]
101 (45.8)	118 (53.4)	2.12 (0.06)

\* External setpoint influence shown with a setpoint of H<sub>max</sub>

Connections: GF65 flanges. See *Pipe connections*, page 60.  
 System pressure: Max. 175 psi (1.2 MPa) (12 bar).  
 Liquid temperature: 14 to 230 °F (-10 to +110 °C) (TF 110).  
 Specific EEI: 0.17.

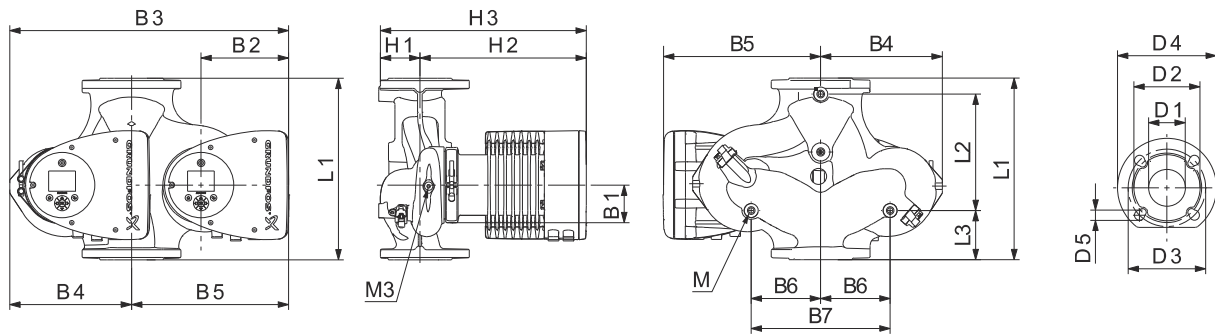

TM05 2205 2214

Pump type	Dimensions [in (mm)]								
	L1	L2	L3	L4	L5	B1	B3	B4	B5
MAGNA3 D 65-150 F	13.4 (340)	8.58 (218)	3.62 (92)	3.62 (92)	8.03 (204)	3.31 (84)	20.55 (522)	8.98 (228)	11.57 (294)
	D1	D2	D3	D4	D5	D5 (2)	M	M1	H1
	2.56 (65)	4.69 (119)	5.12/5.71 (130/145)	7.28 (185)	0.55 (14)	0.75 (19)	M12	Rp 1/4	3.03 (77)

For product numbers, see page 61.

MAGNA3 80-100 F (N)

1 x 230 V, 60 Hz

Proportional pressure

Constant pressure

0-10 volts\*

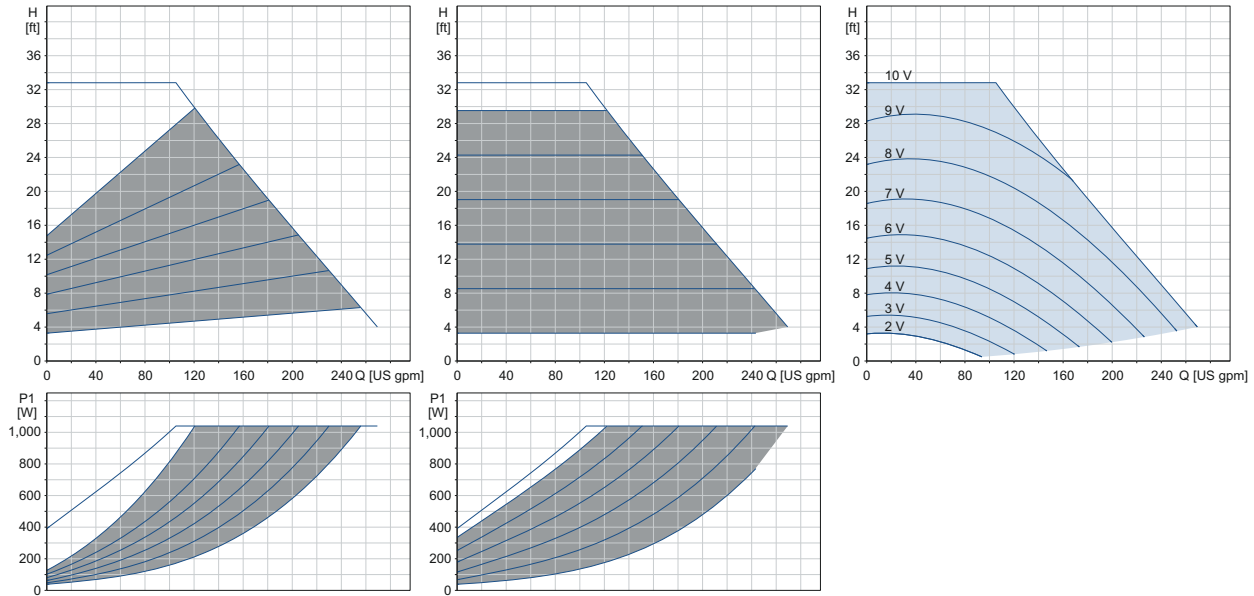

Speed	P1 [W] 230 V	I <sub>1</sub> [A] 230 V
Min.	31	0.32
Max.	1025	4.51

The pump incorporates overload protection.

Net weights [lb (kg)]	Gross weights [lb (kg)]	Ship. vol. [ft <sup>3</sup> (m <sup>3</sup> )]
66.2 (30.0)	72.0 (32.6)	2.47 (0.07)

\* External setpoint influence shown with a setpoint of H<sub>max</sub>

Connections:

GF80 flanges.  
See *Pipe connections*, page 60.

System pressure:

Max. 175 psi (1.2 MPa) (12 bar).

Liquid temperature:

14 to 230 °F (-10 to +110 °C) (TF 110).

Specific EEI:

0.17.

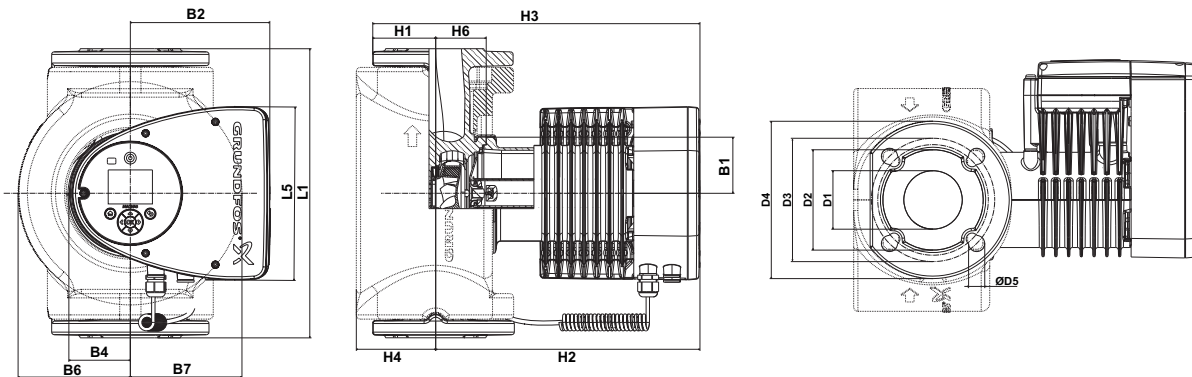

TM05 7652 1413

Pump type	Dimensions [in (mm)]								
	L1	L5	B1	B2	B4	B6	B7	D1	D2
MAGNA3 80-100 F (N)	14.17 (360)	8.03 (204)	3.31 (84)	6.46 (164)	2.87 (73)	6.42 (163)	6.42 (163)	3.15 (80)	5.2 (132)
	D3	D4	D5	H1	H2	H3	H4	H6	
	5.91 (150)	7.87 (200)	0.75 (19)	3.7 (94)	12.52 (318)	16.22 (412)	4.53 (115)	2.6 (66)	

For product numbers, see page 61.

MAGNA3 D 80-100 F

1 x 230 V, 60 Hz

Proportional pressure

Constant pressure

0-10 volt\*

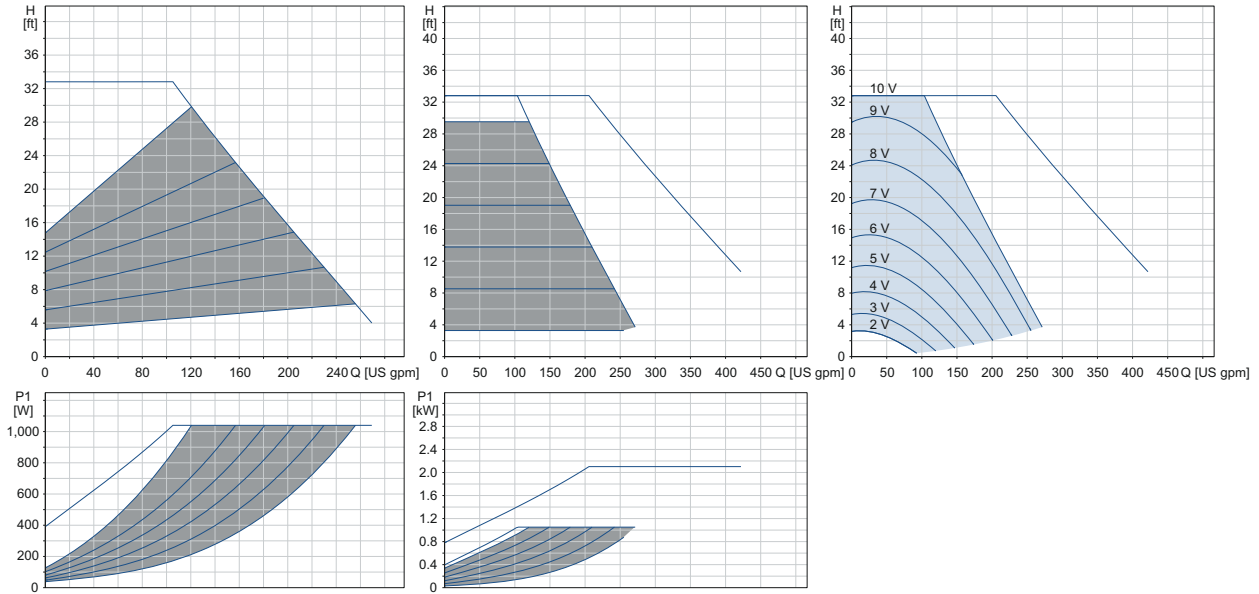

Speed	P1 [W] 230 V	I <sub>1</sub> [A] 230 V
Min.	32	0.32
Max.	1060	4.71

The pump incorporates overload protection.

Net weights [lb (kg)]	Gross weights [lb (kg)]	Ship. vol. [ft <sup>3</sup> (m <sup>3</sup> )]
116.9 (53.0)	138.5 (62.8)	7.5 (0.208)

\* External setpoint influence shown with a setpoint of H<sub>max</sub>

Connections: GF80 flanges. See *Pipe connections*, page 60.  
 System pressure: Max. 175 psi (1.2 MPa) (12 bar).  
 Liquid temperature: 14 to 230 °F (-10 to +110 °C) (TF 110).  
 Specific EEI: 0.17.

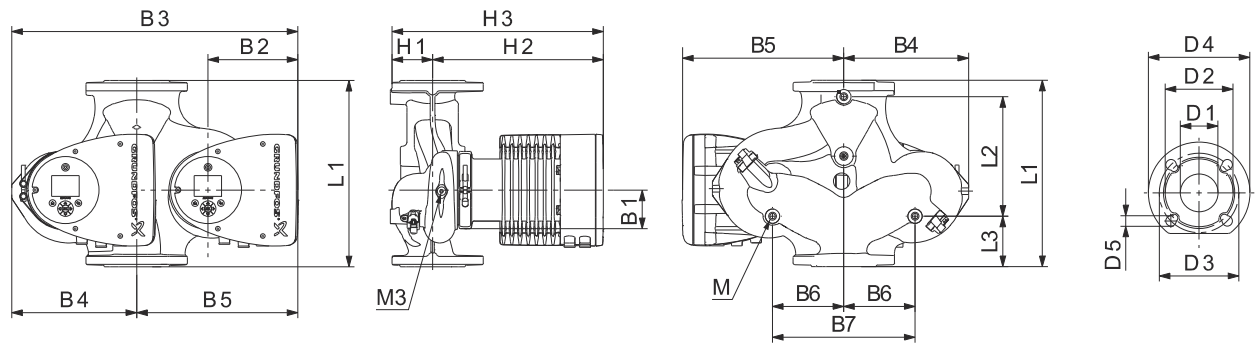

TM05 2205 2214

Pump type	Dimensions [in (mm)]								
	L1	L2	L3	L4	L5	B1	B3	B4	B5
MAGNA3 D 80-100 F	14.17 (360)	8.58 (218)	4.02 (102)	4.02 (102)	8.03 (204)	3.31 (84)	21.18 (538)	9.61 (244)	11.57 (294)
	D1	D2	D3	D3 (2)	D4	D5	M	M1	H1
	3.15 (80)	5.04 (128)	5.91 (150)	6.30 (160)	7.87 (200)	0.75 (19)	M12	Rp 1/4	3.82 (97)

For product numbers, see page 61.

MAGNA3 100-120 F (N)

1 x 230 V, 60 Hz

Proportional pressure

Constant pressure

0-10 volts\*

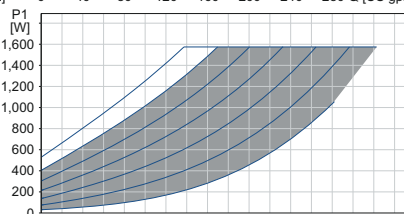
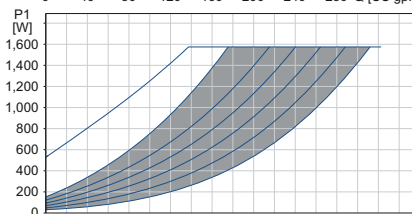
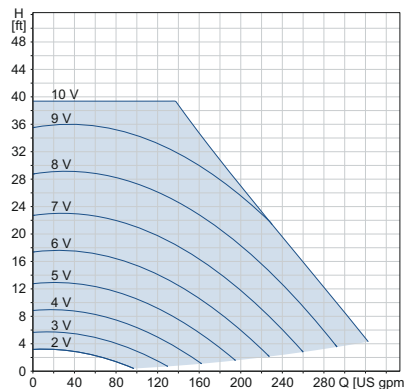
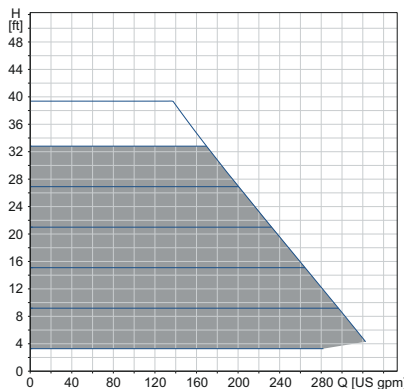
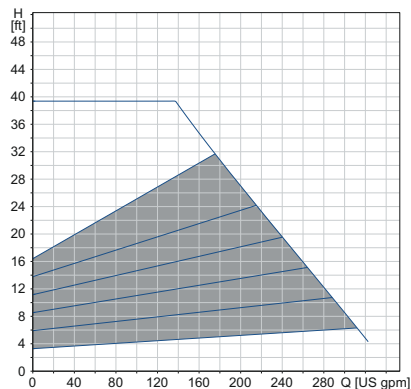

Speed	P1 [W] 230 V	I <sub>1</sub> [A] 230 V
Min.	31	0.32
Max.	1550	6.78

\* External setpoint influence shown with a setpoint of H<sub>max</sub>

The pump incorporates overload protection.

Connections:

GF100 flanges.

See *Pipe connections*, page 60.

System pressure:

Max. 175 psi (1.2 MPa) (12 bar).

Liquid temperature:

14 to 230 °F (-10 to +110 °C) (TF 110).

Specific EEI:

0.17.

Net weights [lb (kg)]	Gross weights [lb (kg)]	Ship. vol. [ft <sup>3</sup> (m <sup>3</sup> )]
76.8 (34.8)	81.6 (37.0)	3.53 (0.1)

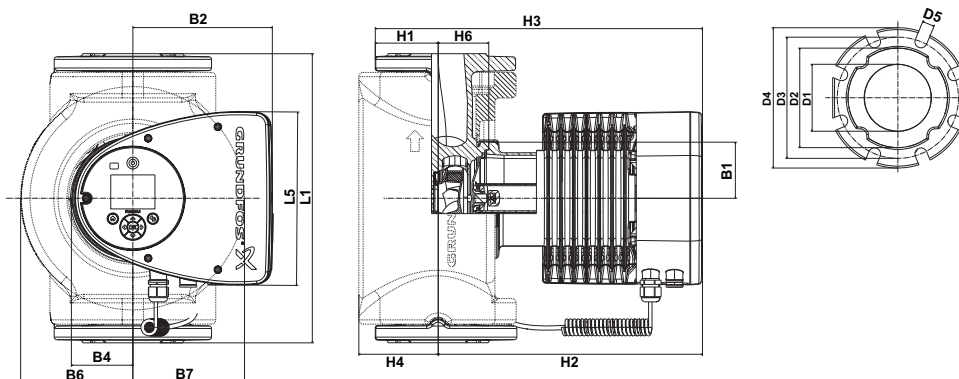

TM05 7650 1413

Pump type	Dimensions [in (mm)]									
	L1	L5	B1	B2	B4	B6	B7	D1	D2	
MAGNA3 100-120 F (N)	17.72 (450)	8.03 (204)	3.31 (84)	6.46 (164)	2.87 (73)	7.01 (178)	7.01 (178)	3.94 (100)	6.14 (156)	
	D3	D4	D5	H1	H2	H3	H4	H6		
	7.52 (191)	8.66 (220)	0.75 (19)	4.02 (102)	12.99 (330)	17.01 (432)	4.72 (120)	3.11 (79)		

For product numbers, see page 61.

MAGNA3 D 100-120 F

1 x 230 V, 60 Hz

Proportional pressure

Constant pressure

0-10 volts\*

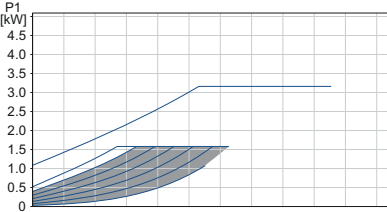
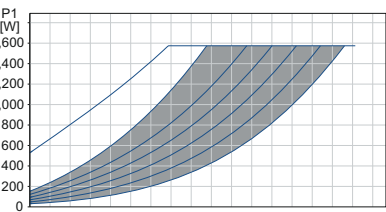
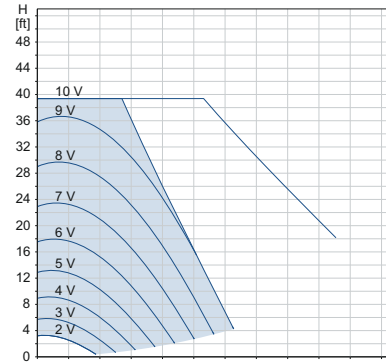
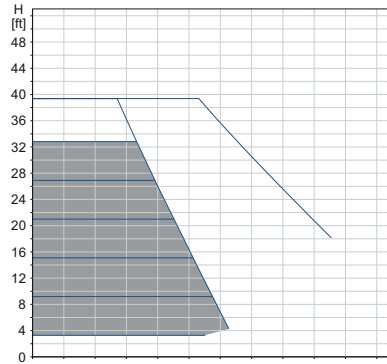
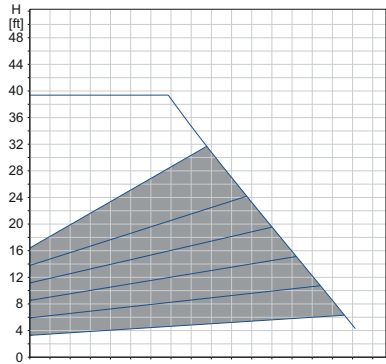

Speed	P1 [W] 230 V	I <sub>1</sub> [A] 230 V
Min.	35	0.35
Max.	1550	6.78

\* External setpoint influence shown with a setpoint of H<sub>max</sub>

Connections: GF100 flanges.  
See *Pipe connections*, page 60.  
System pressure: Max. 175 psi (1.2 MPa) (12 bar).  
Liquid temperature: -14 to 230 °F (10 to +110 °C) (TF 110).  
Specific EEI: 0.17.

The pump incorporates overload protection.

Net weights [lb (kg)]	Gross weights [lb (kg)]	Ship. vol. [ft <sup>3</sup> (m <sup>3</sup> )]
138.3 (62.7)	159.9 (72.5)	7.4 (0.208)

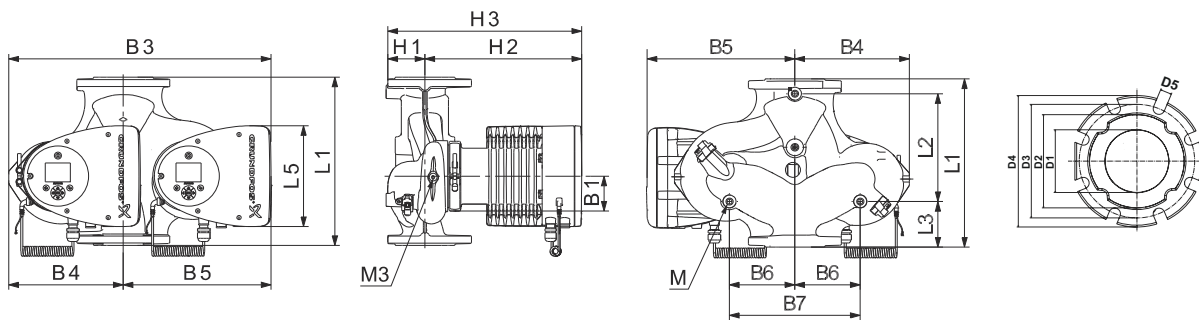

TM05 7701 1214

Pump type	Dimensions [in (mm)]								
	L1	L2	L3	L4	L5	B1	B3	B4	B5
MAGNA3 D 100-120 F	17.72 (450)	9.57 (243)	5.79 (147)	5.79 (147)	8.03 (204)	3.31 (84)	21.69 (551)	9.92 (252)	11.77 (299)
	D1	D2	D3	D4	D5	M	M1	H1	H2
	3.94 (100)	6.3 (160)	6.69 (170)	8.66 (220)	0.75 (19)	M12	Rp 1/4	4.06 (103)	12.99 (330)

For product numbers, see page 61.

# 10. Accessories

## CIM modules

A CIM module is an add-on Communication Interface Module. The CIM module enables data transmission between the pump and an external system, for example a BMS or SCADA system.

The CIM module communicates via fieldbus protocols. The following CIM modules are available:

Module	Fieldbus protocol	Product number
CIM 050	GENibus	96824631
CIM 100	LonWorks	96824797
CIM 150	PROFIBUS DP	96824793
CIM 200	Modbus RTU	96824796
CIM 250	GSM/GPRS	96824795
CIM 270	GRM	96898815
CIM 300	BACnet MS/TP	96893770
CIM 500	Ethernet	98301408

For further information about data communication via CIM modules, see the CIM documentation available in Grundfos Product Center.

### Location of CIM module

The CIM module is fitted behind the front cover. See fig. 56.

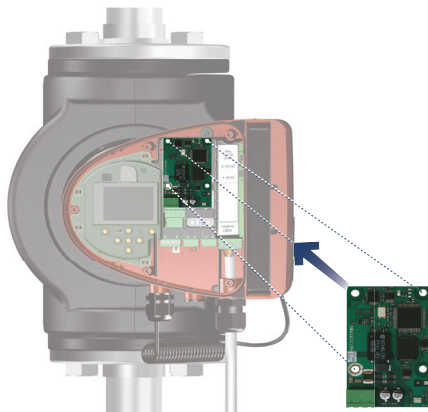

TM05 2914 1112

Fig. 56 Location of CIM module

For installation instructions, please go to:



[net.grundfos.com/qr/i/99258654](http://net.grundfos.com/qr/i/99258654)

### Reuse of CIM modules

You can reuse a CIM module in a CIU unit used together with Grundfos MAGNA in MAGNA3. You must re-configure the CIM module before you use it in a MAGNA3 pump. Contact your local Grundfos company.

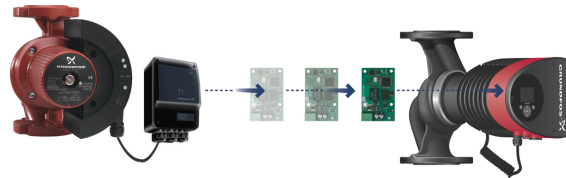

TM05 2911 1312

Fig. 57 Reusing CIM modules

## Grundfos Remote Management

Application	Description	Product number
CIM 270	Grundfos Remote Management (requires a contract with Grundfos and a SIM card).	96898815
GSM antenna for roof mounting	Antenna for use on top of metal cabinets. Vandal-proof. 6.5 ft (2 m) cable. Quad band (global use).	97631956
GSM antenna for desk mounting	Antenna for general-purpose application, for example inside plastic cabinets. To be fixed with the double-adhesive tape supplied. 13 ft (4 m) cable. Quad band (global use).	97631957

For a GRM contract, contact your local Grundfos company.



## Grundfos GO

Grundfos GO is used for infrared or radio communication with the pumps.

Various Grundfos GO variants are available. The variants are described in the following.

### MI 204

MI 204 is an add-on module with built-in infrared and radio communication. You can use MI 204 in conjunction with an Apple iPhone or iPod with Lightning connector, e.g. a fifth generation iPhone or iPod.

MI 204 is also available together with an Apple iPod touch and a cover.



TM05 7704 1513

**Fig. 58** MI 204

Supplied with the product:

- Grundfos MI 204
- sleeve
- quick guide
- charger cable.

### MI 301

MI 301 is a module with built-in infrared and radio communication. Use MI 301 in conjunction with an Android or iOS-based smart device with a Bluetooth connection. MI 301 has a rechargeable Li-ion battery and must be charged separately.



TM05 3890 1712

**Fig. 59** MI 301

Supplied with the product:

- Grundfos MI 301
- battery charger
- quick guide.

### Product numbers

Grundfos GO variant	Product number
Grundfos MI 204	98424092
Grundfos MI 204 including iPod touch	98612711
Grundfos MI 301	98046408

## External Grundfos sensors

### Combined relative-pressure and temperature transmitter

Sensor	Type	Supplier	Measuring range [psi (bar)]	Measuring range [°F (°C)]	Transmitter output [VDC]	Power supply [VDC]	Process connection	Product number
Combined pressure and temperature sensor	RPI T2	Grundfos	0-232 (0-16)	14 to 248 (-10 to +120)	0-10	16.6-30	G 1/2	98355521

Note: MAGNA3 has only one analog input.

### Pressure sensor

Sensor	Type	Measuring range [psi]	Measuring range [bar]	Transmitter output [mA]	Power supply [VDC]	Process connection	Product number
Pressure transmitter	RPI	0-9	(0 - 0.6)	4 to 20	12 to 30	G 1/2	97748907
		0-15	(0 - 1.0)				97748908
		0-25	(0 - 1.6)				97748909
		0-35	(0 - 2.5)				97748910

### 10.1 Adapters

Adapter	
Adapter for 1/4" NPT	98344015

### DPI V.2 transmitter

#### Combined differential-pressure and temperature transmitter

Scope of delivery:

- DPI V.2 transmitter
- open 6.5 ft (2 m) cable with M12 connection in one end
- capillary tube with fitting
- quick guide.



TM04 7866 2510

Fig. 60 DPI V.2 transmitter

Sensor	Measuring range [psi (bar)]	Measuring range [°F (°C)]	Transmitter output	Power supply [VDC]	Temperature measurement	O-ring		Process connection	Product number
						EPDM*	FKM*		
Grundfos DPI	0 - 8.7 (0 - 0.6)	32-212 (0-100)	4-20 mA	12.5 - 30		•		G 1/2	97747194
			4-20 mA	12.5 - 30		•	•		97747215
			0-10 VDC	16.5 - 30	•	•			97747202
			0-10 VDC	16.5 - 30	•	•			97747244
Grundfos DPI	0 - 14.5 (0 - 1.0)	32-212 (0-100)	4-20 mA	12.5 - 30		•		G 1/2	97747195
			4-20 mA	12.5 - 30		•	•		97747216
			0-10 VDC	16.5 - 30	•	•			97747203
			0-10 VDC	16.5 - 30	•	•			97747245
Grundfos DPI	0 - 23.2 (0 - 1.6)	32-212 (0-100)	4-20 mA	12.5 - 30		•		G 1/2	97747196
			4-20 mA	12.5 - 30		•	•		97747218
			0-10 VDC	16.5 - 30	•	•			97747204
			0-10 VDC	16.5 - 30	•	•			97747246
Grundfos DPI	0 - 36.26 (0 - 2.5)	32-212 (0-100)	4-20 mA	12.5 - 30		•		G 1/2	97747197
			4-20 mA	12.5 - 30		•	•		97747219
			0-10 VDC	16.5 - 30	•	•			97747205
			0-10 VDC	16.5 - 30	•	•			97747247

\* Note:  
EPDM: approved for potable water.  
FKM: for use in oily media.

## Cable for sensors

Description	Length [ft (m)]	Product number
Screened cable	6.5 (2.0)	98374260
Screened cable	16.4 (5.0)	98374271

## Blanking flange

A blanking flange is used to blank off the opening when one of the pump heads of a twin-head pump is removed for service to enable uninterrupted operation of the other pump.

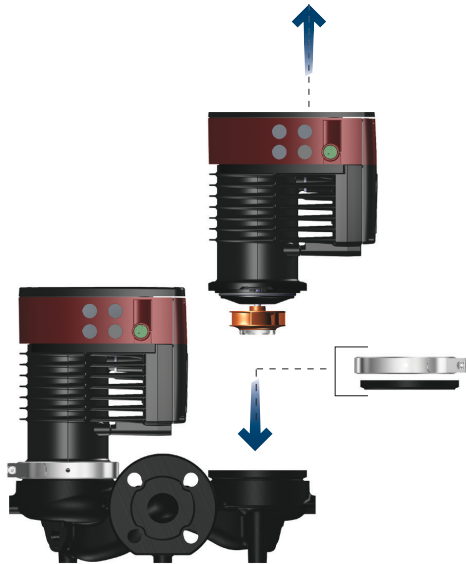

TM06 8518 0817

**Fig. 61** Position of a blanking flange

Pump type	Product number
MAGNA3 D 65-150 F	98159372
MAGNA3 D 80-100 F	
MAGNA3 D 100-120 F	

## Pipe connections

Material	Flange	Description	Part number
		3/4" NPT flange fitting set	519601
		1" NPT flange fitting set	519602
	GF 15/26 flange	1-1/4" NPT flange fitting set	519603
		1-1/2" NPT flange fitting set	519604
	GF 40/43 flange	1-1/2" NPT flange fitting set	539605
Cast iron	GF 50 flange	2" NPT flange fitting set	96409354
		2" NPT flange fitting set	91584910
	GF 53 flange	2-1/2" NPT flange fitting set	91584911
		3" NPT flange fitting set	91584912
	GF 65 flange	2-1/2" NPT flange fitting set	559601
	GF 80 flange	3" NPT flange fitting set	569601
	GF 100 flange	4" NPT flange fitting set	579801
Stainless steel	GF 65 flange	Stainless steel, 2-1/2" NPT flange fitting set	91121951
<b>Replacement flange gaskets</b>			
GF 15/40		2-bolt, single o-ring for 1-1/2" flange	98476425

## 11. Product numbers

### Single-head pumps

Single-head pump type	Port-to-port length [in. (mm)]	Flange connection	Cast iron		Stainless steel (N)		Page
			115 V	208-230 V	115 V	208-230 V	
MAGNA3 40-80 F (N)	8 - 9/16 (216)	PN 12	98126800	98126828	98126802	98126830	44
MAGNA3 40-120 F (N)	8 - 9/16 (216)	PN 12	98126804	98126832	98126806	98126834	45
MAGNA3 40-180 F (N)	8 - 9/16 (216)	PN 12	98126808	98126836	98126810	98126838	46
MAGNA3 50-80 F (N)	9 - 1/2 (240)	PN 12	98126812	98126840	98126814	98126842	47
MAGNA3 50-150 F (N)	11 - 1/16 (280)	PN 12	98126816	98126844	98126818	98126846	48
MAGNA3 65-120 F (N)	13 - 7/16 (340)	PN 12	98124696	98126848	98124702	98126850	49
MAGNA3 65-150 F (N)	13 - 7/16 (340)	PN 12	-	98126852	-	98126854	50
MAGNA3 80-100 F (N)	14 - 3/16 (360)	PN 12	-	98126856	-	98126858	52
MAGNA3 100-120 F (N)	17 - 3/4 (450)	PN 12	-	98126860	-	98126862	54

### Twin-head pumps

Twin-head pump type	Port-to-port length [in. (mm)]	Flange connection	Cast iron		Stainless steel (N)		Page
			115 V	208-230 V	115 V	208-230 V	
MAGNA3 D 65-150 F	13 - 7/16 (340)	PN 12	-	98126863	-	-	51
MAGNA3 D 80-100 F	14 - 3/16 (360)	PN 12	-	98126864	-	-	53
MAGNA3 D 100-120 F	17 - 3/4 (450)	PN 12	-	98126865	-	-	55

**Note:** Click on the product number and go directly to the performance curve in Grundfos Product Center.

# 12. Grundfos Product Center

Online search and sizing tool to help you make the right choice.

<http://product-selection.grundfos.com>

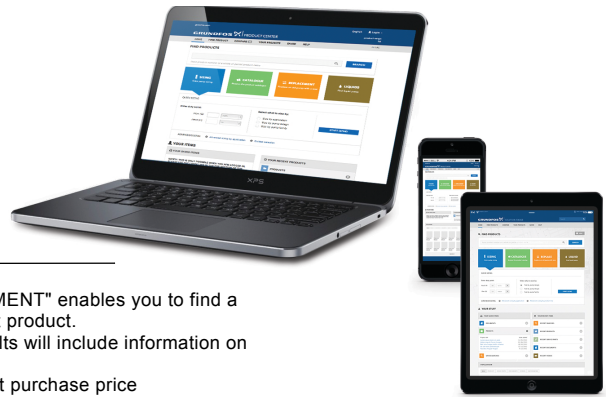

"SIZING" enables you to size a pump based on entered data and selection choices.

"REPLACEMENT" enables you to find a replacement product. Search results will include information on

- the lowest purchase price
- the lowest energy consumption
- the lowest total life cycle cost.

"CATALOG" gives you access to the Grundfos product catalog.

"LIQUIDS" enables you to find pumps designed for aggressive, flammable or other special liquids.

### All the information you need in one place

Performance curves, technical specifications, pictures, dimensional drawings, motor curves, wiring diagrams, spare parts, service kits, 3D drawings, documents, system parts. The Product Center displays any recent and saved items - including complete projects - right on the main page.

### Downloads

On the product pages, you can download installation and operating instructions, data booklets, service instructions, etc. in PDF format.

Subject to alterations.



99332363 1117

ECM: 1222232

**Grundfos Kansas City**

17100 West 118th Terrace  
Olathe, Kansas 66061  
Phone: 913-227-3400  
Fax: 913-227-3500  
[www.grundfos.us](http://www.grundfos.us)

**Grundfos Canada**

2941 Brighton Road  
Oakville, Ontario L6H 6C9 Canada  
Phone: +1-905-829-9533  
Fax: +1-905-829-9512  
[www.grundfos.ca](http://www.grundfos.ca)

**Grundfos México**

Boulevard TLC No. 15  
Parque Industrial Stiva Aeropuerto  
C.P. 66600 Apodaca, N.L. Mexico  
Phone: 011-52-81-8144 4000  
Fax: 011-52-81-8144 4010  
[www.grundfos.mx](http://www.grundfos.mx)