



AIM MANUAL

60 Hz SUBMERSIBLE SYSTEMS

APPLICATION | INSTALLATION | MAINTENANCE

2023 EDITION





YOUR FRANKLIN EXPERIENCE RUNS
BEYOND THE PUMP

You don't run without teamwork—and neither do we. Our goal is to build not only reliable, trustworthy products, but to back them with the people, resources and support you need to get your job done and keep your business flowing: we're here for you, every step of the way.

TABLE OF CONTENTS

SAFETY INSTRUCTIONS- - - - -	-1
Hazard Messages - - - - -	-1
Before Getting Started - - - - -	-1
MOTOR APPLICATION - - - - -	3
Storage - - - - -	3
Control Box, Pumptec Products, and Panel Environment- - - - -	3
Frequency of Starts - - - - -	3
Mounting Position - - - - -	4
Transformer Capacity - - - - -	4
Engine Driven Generators - - - - -	5
<i>Generator Operation-</i> - - - - -	5
<i>Generator Minimum Rating</i> - - - - -	6
Effects of Torque- - - - -	7
Check Valve Use - - - - -	7
Drawdown Seals- - - - -	8
Well Applications - - - - -	8
Water Temperature and Flow - - - - -	9
<i>Required Cooling Flow-</i> - - - - -	9
<i>Flow Inducer Sleeve</i> - - - - -	10
Hot Water Applications (Standard Motors) - - - - -	10
<i>Head Loss-</i> - - - - -	11
Equipment Grounding - - - - -	11
Grounding Control Boxes and Panels - - - - -	11
Single-Phase Motors - - - - -	12
<i>2-Wire Motor Solid State Controls</i> - - - - -	12
BIAC Switch Operation - - - - -	12
Rapid Cycling- - - - -	12
Bound Pump (Sand-Locked) - - - - -	12
<i>3-Wire Control Boxes</i> - - - - -	13
QD Relays (Solid State) - - - - -	13
Potential (Voltage) Relays - - - - -	13
Auxiliary Running Capacitors - - - - -	14
Auxiliary Capacitor Sizing - - - - -	14
<i>Buck-Boost Transformers</i> - - - - -	14
<i>Buck-Boost Transformer Sizing-</i> - - - - -	15
Three-Phase Motors - - - - -	15
<i>Power Connections and Transformers</i> - - - - -	15
<i>Power Factor Correction</i> - - - - -	15
kVAR Required - - - - -	16
<i>Phase Converters</i> - - - - -	17

TABLE OF CONTENTS

<i>Reduced Voltage Starters (RVS)</i>	-17
<i>Three-Phase Starter Diagrams</i>	-18
Line Voltage Control	-18
Low Voltage Transformer Control	-19
External Voltage Controls	-19
<i>Overload Protection of Three-Phase Submersible Motors</i>	20
<i>Three-Phase Power Unbalance</i>	20
<i>Motor Rotation</i>	-21
CCW Rotation Lead Phase Designation	-21
<i>Current Unbalance</i>	-21
<i>Three-Phase Motor Lead Identification</i>	22
90° Lead Spacing	22
<i>Inline Booster Pump Systems</i>	23
Design and Operational Requirements	23
Four Continuous Monitoring System Requirements for Sealed Booster Systems	27
<i>Variable Frequency Drive Submersible Motor Requirements</i>	28
Output Filter Requirement Test	28
Filtering Guidelines	28
VFD Filter Sizing	28
Filter & Reactor Types	29
VFD Output Filtering Requirements	29
Input Current & Motor Overload Protection	29
Motor Maximum Load Limits	29
Motor Operating Hertz, Cooling Requirements, and Underload Settings	29
VFD Frequency of Starts	30
Starting and Stopping Ramp Settings	30
Drive Carrier Frequency	30
Application Function Setting	30
VFD Pressure Tank Sizing	30
NEMA MG1 Above Ground Motor Standard Comments	30
INSTALLATION	-31
Submersible Motor Dimensions for a Standard Water Well	-31
Submersible Leads and Cables	33
Lead Connector Jam Nut Torque	33
Pump to Motor Coupling Assembly	33
Pump to Motor Assembly Torque	33
Shaft Height and Free End Play	34

MOTOR MAINTENANCE - - - - -	- 35
System Troubleshooting - - - - -	- 35
Preliminary Tests - - - - -	- 36
<i>Insulation Resistance</i> - - - - -	- 36
Insulation Resistance Readings - - - - -	- 37
<i>Winding Resistance</i> - - - - -	- 37
Resistance of Drop Cable (ohms) - - - - -	- 38
Single-Phase Motors & Controls - - - - -	- 38
<i>Cable Identification</i> - - - - -	- 38
<i>Control Box Checks</i> - - - - -	- 39
Voltage Measurements - - - - -	- 39
Current (Amp) Measurements - - - - -	- 39
<i>Ohmmeter Tests</i> - - - - -	- 40
QD, Solid State Control Box - - - - -	- 40
Integral Horsepower Control Box - - - - -	- 40
Ordering Information - - - - -	- 41
QD Control Box Parts - - - - -	- 41
Integral Horsepower Control Box Parts - - - - -	- 42
<i>Control Box Wiring Diagrams</i> - - - - -	- 44
Motor, Cable, & Fuse/Circuit Breaker Reference - - - - -	- 49
<i>Motor Specifications</i> - - - - -	- 49
<i>Cable Selection</i> - - - - -	- 49
<i>Cable Size Combinations</i> - - - - -	- 50
<i>Motor Fuses/Circuit Breakers</i> - - - - -	- 50
<i>4-inch Motor, Cable, & Fuse/Circuit Breaker Reference</i> - - - - -	- 51
4-inch / Single-Phase / Encapsulated Motor Specs - - - - -	- 51
4-inch / Single-Phase / Encapsulated Motor Specs with a "G" suffix - - - - -	- 52
4-inch / Single-Phase / Encapsulated Motor Specs 700 series- - - - -	- 53
4-inch / Single-Phase / 75 °C Cable - - - - -	- 53
4-inch / Single-Phase / Encapsulated Motor Fuse Sizing - - - - -	- 54
4-inch / Three-Phase / 3-Lead / Encapsulated Motor Specs- - - - -	- 55
4-inch / Three-Phase / 3-Lead / Encapsulated Motor Specs with a "G" suffix - - - - -	- 56
4-inch / Three-Phase / 3-Lead / Encapsulated Motor Specs 700 series - - - - -	- 57
4-inch / Three-Phase / 3-Lead / 75 °C Cable - - - - -	- 58
4-inch / Three-Phase / 3-Lead / Encapsulated Motor Fuse Sizing - - - - -	- 60
4-inch / Three-Phase / Encapsulated Permanent Magnet Motor Specs - - - - -	- 61
4-inch / Three-Phase / 3-Lead / Encapsulated Permanent Magnet Motor 75 °C Cable - - - - -	- 61
4-inch / Three-Phase / Encapsulated Permanent Magnet Motor Fuse Sizing - - - - -	- 62
<i>6-inch Motor, Cable, & Fuse/Circuit Breaker Reference</i> - - - - -	- 63
6-inch / Single-Phase / Encapsulated Motor Specs - - - - -	- 63
6-inch / Single-Phase / 75 °C Cable - - - - -	- 63
6-inch / Single-Phase / Encapsulated Motor Fuse Sizing - - - - -	- 64

TABLE OF CONTENTS

6-inch / Three-Phase / 3-Lead / Encapsulated Motor Specs - - - - -	65
6-inch / Three-Phase / 3-Lead / Encapsulated Motor Specs Hi-Temp (90 °C) - - - - -	66
6-inch / Three-Phase / 6-Lead / Encapsulated Motor Specs - - - - -	67
6-inch / Three-Phase / 3-Lead / 75 °C Cable - - - - -	67
6-inch / Three-Phase / 6-Lead / 75 °C Cable - - - - -	69
6-inch / Three-Phase / 3-Lead / Standard & Hi-Temp (90 °C) Encapsulated Motor Fuse Sizing	70
6-inch / Three-Phase / 6-Lead / Motor Fuse Sizing - - - - -	71
6-inch / Three-Phase / Encapsulated Permanent Magnet Motor Specs - - - - -	72
6-inch / Three-Phase / Encapsulated Permanent Magnet Motor 75 °C Cable - - - - -	72
6-inch / Three-Phase / Encapsulated Permanent Magnet Motor Fuse Sizing - - - - -	72
<i>8-inch Motor, Cable, & Fuse/Circuit Breaker Reference - - - - -</i>	<i>73</i>
8-inch / Three-Phase / 3-Lead / Encapsulated Motor Specs - - - - -	73
8-inch / Three-Phase / 3-Lead / Encapsulated Motor Specs Hi-Temp (75 °C) - - - - -	74
8-inch / Three-Phase / 3-Lead / 75 °C Cable - - - - -	75
8-inch / Three-Phase / 6-Lead / 75 °C Cable - - - - -	76
8-inch / Three-Phase / 3-Lead / Standard Encapsulated Motor Fuse Sizing - - - - -	77
8-inch / Three-Phase / 3-Lead / Hi-Temp (75 °C) Motor Fuse Sizing - - - - -	78
8-inch / Three-Phase / Rewindable Permanent Magnet Motor Specs - - - - -	78
8-inch / Three-Phase / Rewindable Permanent Magnet Motor 75 °C Cable - - - - -	79
8-inch / Three-Phase / Encapsulated Permanent Magnet Motor Fuse Sizing - - - - -	79
<i>10-inch Motor, Cable, & Fuse/Circuit Breaker Reference - - - - -</i>	<i>80</i>
10-inch / Three-Phase / Rewindable Motor Specs - - - - -	80
10-inch / Three-Phase / Rewindable Motor Specs - - - - -	80
10-inch / Three-Phase / 3-Lead / Rewindable Motor 75 °C Cable - - - - -	80
10-inch / Three-Phase / 6-Lead / Rewindable Motor 75 °C Cable - - - - -	81
10-inch / Three-Phase / Rewindable MagForce Motor 75°C Cable - - - - -	81
10-inch / Three-Phase / Rewindable MagForce Fuse Sizing - - - - -	81
<i>12-inch Motor, Cable, & Fuse/Circuit Breaker Reference - - - - -</i>	<i>82</i>
12-inch / Three-Phase / Rewindable Motor Specs - - - - -	82
12-inch / 4-Pole / Three-Phase / Rewindable Motor Specs - - - - -	82
12-inch / Three-Phase / 6-Lead / Rewindable Motor Specs - - - - -	82
12-inch / Three-Phase / 3-Lead / Rewindable Motor 75 °C Cable - - - - -	83
12-inch / Three-Phase / 6-Lead / Rewindable Motor 75 °C Cable - - - - -	83
12-inch / Three-Phase / Rewindable Motor Fuse Sizing - - - - -	84
MOTOR GLOSSARY - - - - -	85

CONTROLS APPLICATION-	- 87
Pumptec Family	- 87
SubMonitor Connect	- 87
SubDrive	- 87
Cerus X-Drive	- 87
Control and Protection Features	- 88
Checking Power for Controls	- 89
VFD Generator Sizing / SubDrive	- 90
VFD Generator Sizing / X-Drive-	- 90
Cable Routing	- 91
Fuse/Circuit Breaker and Wire Sizing	- 91
<i>Circuit Breaker Sizing & Max Input Cable Lengths / SubDrive</i>	- 92
<i>Circuit Breaker Sizing & Max Input Cable Lengths / X-Drive</i>	- 93
<i>Motor Cable Sizing-</i>	- 93
Pressure Tank	- 93
<i>Pressure Tank Pre-charge</i>	- 93
<i>Minimum Supply Pipes-</i>	- 94
CONTROLS MAINTENANCE	- 95
Pumptec-Plus: Troubleshooting During Installation	- 95
Pumptec-Plus and PumpteC with 3 Lights: Troubleshooting After Installation-	- 96
SubMonitor Connect: Fault and Alarm Descriptions	- 96
SubDrive/MonoDrive NEMA 1 and NEMA 4 Troubleshooting	- 98
<i>Diagnostic Fault Codes-</i>	- 98
<i>Symptom Based Troubleshooting</i>	- 100
SubDrive Utility UT2W Maintenance	-101
<i>Diagnostic Fault Codes-</i>	- 101
<i>Symptom Based Troubleshooting</i>	- 103
SubDrive Utility UT3 Maintenance	- 106
<i>Diagnostic Fault Codes-</i>	- 106
<i>Symptom Based Troubleshooting</i>	- 108
SubDrive Connect Maintenance-	-110
<i>Diagnostic Fault Codes-</i>	- 110
<i>Symptom Based Troubleshooting</i>	- 114
SubDrive Connect Plus Maintenance	-116
<i>Diagnostic Fault Codes-</i>	- 116
<i>Symptom Based Troubleshooting</i>	- 119
Cerus X-Drive Maintenance-	-121
<i>Troubleshooting-</i>	-121
<i>Diagnostic Fault Codes-</i>	- 122
<i>Diagnostic Warning Codes</i>	- 133
CONTROLS GLOSSARY	-141
FORMULAS-	- 142

FOREWORD

In an ever-changing industry, knowledge is vital to your job. Since the 1960s, the Franklin Electric AIM manual has been directed at helping you navigate questions related to submersible motor Application, Installation, and Maintenance.

This manual has evolved over the years from a fundamental technical tool that supplied essential motor data to a more comprehensive installation and maintenance guide. A few years ago, we developed the AIM App to provide this information with increased usability, right from your pocket.

With the introduction of the MagForce motor, 10-inch & 12-inch Rewindable motors and new drive technology, we continue to enhance our support. Franklin Electric strives to adapt to your growing needs through quality products and technical guidance. The AIM manual is an essential part of this mission.

Welcome to the 2023 edition of the AIM Manual. In this updated tool you will find:

- A new format, aligned with current Franklin Electric owner's manuals
- Thorough reference tables for motor specifications, cable sizing, and motor fuse sizing, supporting the full range of Franklin Electric motors
- New, clear graphics to help you understand what you are seeing in the field
- Comprehensive, current controls application and maintenance sections, including fault codes and troubleshooting.

While much has changed, what has remained constant is the volume of knowledge that goes into building this tool. Every edition of this manual utilizes the expertise of engineers and technical specialists with decades of experience.

We're proud to support and partner with industry professionals like you. We hope that the 2023 AIM manual continues to provide the information needed to make your job easier.

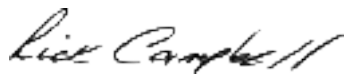

Rick Campbell
Manager, Technical Support

SAFETY INSTRUCTIONS

Hazard Messages

This manual includes safety precautions and other important information in the following formats:

DANGER

Indicates an imminently hazardous situation which, if not avoided, will result in death or serious injury.

WARNING

Indicates a potentially hazardous situation which, if not avoided, could result in death or serious injury.

CAUTION

Indicates a potentially hazardous situation which, if not avoided, could result in minor or moderate personal injury.

NOTICE

Indicates a potentially hazardous situation which, if not avoided could result in damage to equipment or other property.

IMPORTANT: Identifies information that controls correct assembly and operation of the product.

NOTE: Identifies helpful or clarifying information.

 This symbol alerts the user to the presence of dangerous voltage inside the product that might cause harm or electrical shock.

 This symbol alerts the user to the presence of hot surfaces that might cause fire or personal injury

Before Getting Started

This equipment should be installed and serviced by technically qualified personnel who are familiar with the correct selection and use of appropriate tools, equipment, and procedures. Failure to comply with national and local electrical and plumbing codes and within Franklin Electric recommendations may result in electrical shock or fire hazard, unsatisfactory performance, or equipment failure.

Read and follow instructions in this and other product specific manuals carefully to avoid injury and property damage. Do not disassemble or repair unit unless described in the manual.

Failure to follow installation or operation procedures and all applicable codes may result in the following hazards:

WARNING

 **High voltages capable of causing severe injury or death by electrical shock are present in this unit.**

- To reduce risk of electrical shock, disconnect power before working on or around the system. More than one disconnect switch may be required to de-energize the equipment before servicing.
- Some controls can hold lethal voltage after power has been disconnected. Allow 5 minutes for dangerous internal voltage to discharge before removing covers or working with internal components.
- Make sure the ground terminal is connected to the motor, control enclosures, metal plumbing, and other metal near the motor or cable using wire no smaller than motor cable wires.

CAUTION

  **Risk of bodily injury, electric shock, or property damage.**

- This equipment must not be used by children or persons with reduced physical, sensory or mental abilities, or lacking in experience and expertise, unless supervised or instructed. Children may not use the equipment, nor may they play with the unit or in the immediate vicinity.
- Operation of this equipment requires detailed installation and operation instructions provided in the owner's manual for use with each product. Read entire owner's manual before starting installation and operation. End User should receive and retain manual for future use.
- Keep safety labels clean and in good condition.

Basic Water System Components

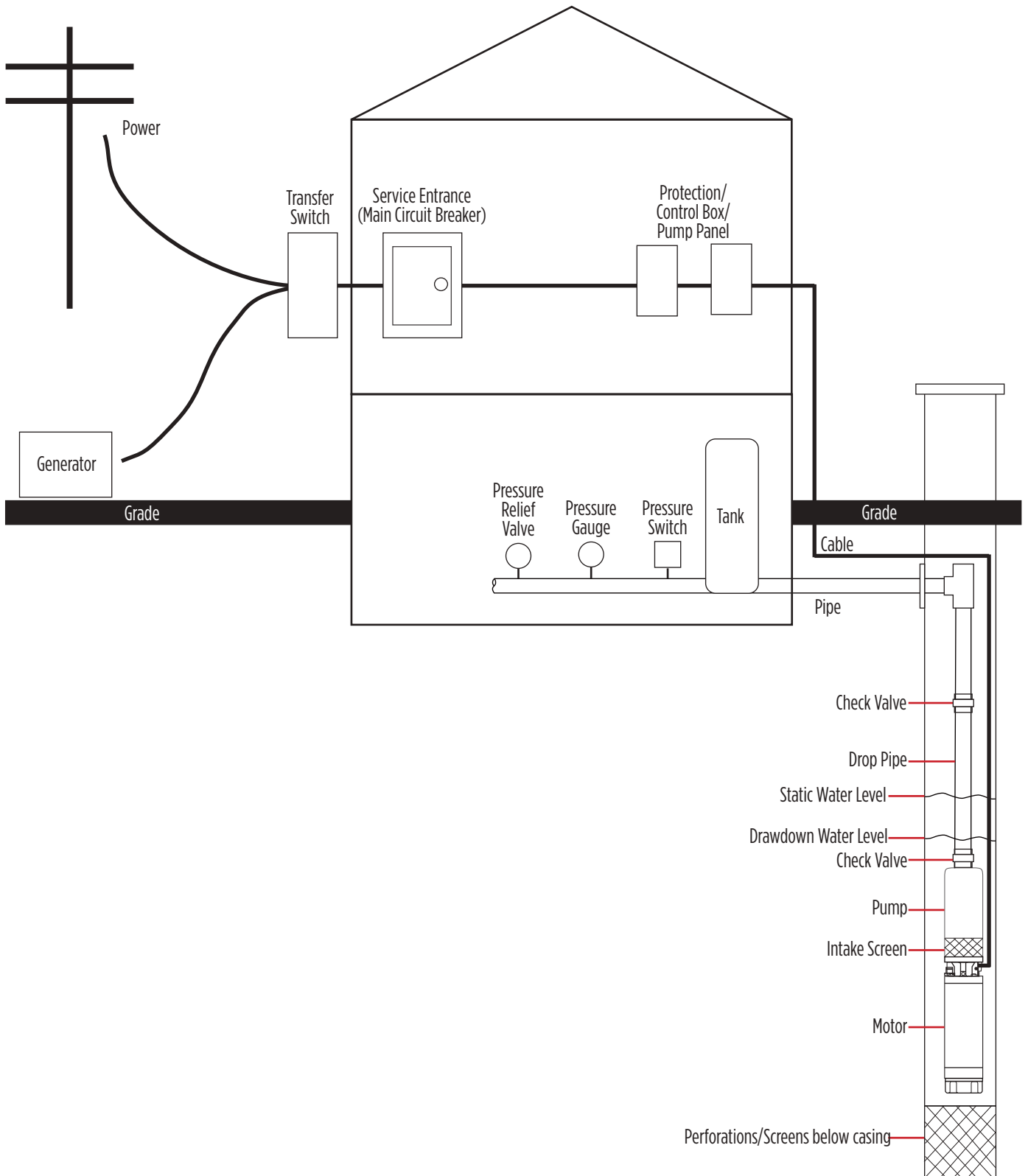

MOTOR APPLICATION

Storage

Franklin Electric submersible motors are a water-lubricated design. The fill solution is a non-toxic water based mixture. This solution prevents damage from freezing in temperatures of -40 °F (-40 °C) and above; do not store motors in areas that go below this temperature. The solution will partially freeze below 27 °F (-3 °C), but no damage occurs. Avoid repeated freezing and thawing to prevent loss of fill solution.

Remove motors from wells carefully during freezing conditions to prevent damage. There may be an interchange of fill solution with well water during operation.

When the storage temperature does not exceed 100 °F (37 °C), limit storage time to two years. When temperatures reach 100 °F to 130 °F, limit storage time to one year.

Loss of a few drops of liquid does not damage the motor because an excess amount is provided. The filter/check valve allows lost liquid to be replaced by filtered well water upon installation. If there has been a considerable amount of leakage, consult the factory for checking procedures.

Control Box, Pumptec Products, and Panel Environment

Franklin Electric control boxes, Pumptec products and three-phase panels meet UL requirements for NEMA Type 3R enclosures.

- Install in indoor and outdoor applications within temperatures of 14 °F (-10 °C) to 122 °F (50 °C). Operating control boxes below 14 °F can cause reduced starting torque and loss of overload protection when overloads are located in control boxes.
- Never mount in direct sunlight or high temperature locations, which cause shortened capacitor life (if applicable) and unnecessary tripping of overload protectors.
- Use a ventilated enclosure, painted white to reflect heat, for an outdoor, high-temperature location.
- Do not install in a damp well pit, or other humid location, which accelerate component failure from corrosion.
- Mount control boxes with voltage relays in a vertical upright position only. Mounting in other positions affects the operation of the relay.

Frequency of Starts

Keep the average number of starts per day within the recommended numbers to provide the best system life. Excessive cycling reduces the life of control components such as pressure switches, starters, relays, and capacitors. It can also cause motor spline damage, bearing damage, and motor overheating.

- Select the pump size, tank size, and other controls to keep the starts per day as low as practical. Refer to [“Table 1” on page 3](#).
- Run motors a minimum of one minute to dissipate heat build up from starting current.
- Keep at least 15 minutes between starts or starting attempts for six-inch and larger encapsulated motors without RVS or VFDs.

NOTE: *7.5 through 30 hp three-phase encapsulated motors can be started up to 200 times per 24 hour period, when used with a properly configured Reduced Voltage Starter (RVS) or Variable Frequency Drive (VFD).

Table 1.

Motor Type	Motor Rating		Maximum Starts per 24 Hr Period	
	HP	KW	Single-Phase	Three-Phase
Encapsulated	Up to 0.75	Up to 0.55	300	
	1 – 5.5	0.75 – 4	100	300
	7.5 – 30	5.5 – 22	50	100*
	40 – 200	30 – 150	–	100
Rewindable	75 – 540	55 – 400	–	120

Mounting Position

Franklin Electric submersible motors are designed primarily to operate in the vertical, shaft-up position.

During acceleration, the pump thrust increases as its output head increases. In cases where the pump head stays below its normal operating range during start-up and full speed condition, the pump may create upward thrust on the motor upthrust bearing. This is an acceptable operation for short periods at each start, but running continuously with upthrust will cause excessive wear on the up thrust bearing.

With certain restrictions listed below, motors are also suitable for operation in positions from shaft-up to shaft-horizontal. As the mounting position becomes closer to horizontal, the probability of shortened thrust bearing life increases. For normal motor life expectancy with motor positions other than shaft-up:

1. Minimize the frequency of starts to fewer than 10 per 24 hour period. Ensure six- and eight-inch motors have a minimum of 20 minutes between starts or starting attempts
2. Do not use in systems than can run for short periods at full speed without thrust toward the motor.
3. Raise shaft end 15 degrees from horizontal.

Transformer Capacity

Adequately size distribution transformers to satisfy the kVA requirements of the submersible motor. When transformers are too small to supply the load, voltage to the motor decreases. Other loads would add directly to the kVA sizing requirements of the transformer bank.

[“Table 2” on page 4](#) references the motor horsepower rating, single- and three-phase, and the smallest transformer required for open or closed three-phase systems. While not recommended, open systems require larger transformers because only two transformers are used. Refer to [“Current Unbalance” on page 21](#).

Table 2.

Motor Rating		Total Effective kVA Required	Smallest kVA Rating (each transformer)	
HP	KW		Open Wye or Delta 2-Transformers	Closed Wye or 3-Transformers
1.5	1.1	3	2	1
2	1.5	4	2	1.5
3	2.2	5	3	2
5	3.7	7.5	5	3
7.5	5.5	10	7.5	5
10	7.5	15	10	5
15	11	20	15	7.5
20	15	25	15	10
25	18.5	30	20	10
30	22	40	25	15
40	30	50	30	20
50	37	60	35	20
60	45	75	40	25
75	55	90	50	30
100	75	120	65	40
125	93	150	85	50
150	110	175	100	60
175	130	200	115	70
200	150	230	130	75
250	185	300	175	100
300	220	340	200	115
335	250	370	215	125

Table 2 (continued)

Motor Rating		Total Effective kVA Required	Smallest kVA Rating (each transformer)	
HP	KW		Open Wye or Delta 2-Transformers	Closed Wye or 3-Transformers
400	300	430	250	145
470	350	520	300	175
540	400	600	350	200

NOTE: Standard kVA ratings are shown. If the power company allows transformer loading higher than standard, higher loading values may be used to meet total effective kVA required, as long as correct voltage and balance are maintained.

Engine Driven Generators

Engine driven generators can be externally or internally regulated. Most are externally regulated. They use an external voltage regulator that senses the output voltage. As the voltage dips at motor start-up, the regulator increases the output voltage of the generator.

Generators must be sized to deliver at least 65% of the motor’s rated nameplate voltage during starting to ensure adequate starting torque.

Motor speed varies with generator frequency (Hz).

- Due to pump affinity laws, a pump running at 1 to 2 Hz below motor nameplate frequency design will not meet its performance curve.
- A pump running at 1 to 2 Hz above may trip overloads.

Generator Operation

⚠ WARNING

 **High voltages capable of causing severe injury or death by electrical shock are present in this unit.**

- To prevent accidental electrocution, automatic or manual transfer switches must be used any time a generator is used as standby or back up on power lines. Contact power company for use and approval.

⚠ CAUTION

 **Risk of bodily injury, electric shock, or property damage.**

- Do not used a Reduced Voltage Starter with a minimum sized generator. Both items drop the output voltage and combing these items causes the potential for severe motor damage and failure due to low voltage.

Always start the generator before turning on the motor and always turn off the motor before shutting down the generator. The motor thrust bearing may be damaged if the generator is allowed to coast down with the motor running or if it runs out of fuel.

Follow the generator manufacturer’s recommendations to de-rate at higher elevations or use natural gas.

NOTE: Using the minimum rating or sized generator acts as a soft start to the motor. No additional voltage reduction is allowed.

MOTOR APPLICATION
Engine Driven Generators

Generator Minimum Rating

NOTE: This table applies to 2-wire, 3-wire, or 3-phase motors. For best starting of 2-wire motors, the minimum generator rating is 50% higher than shown.

Table 3.

Motor Rating		Minimum Rating (Externally Regulated)	
HP	KW	KW	kVA
1/3	0.25	1.5	1.9
1/2	0.37	2	2.5
3/4	0.55	3	3.8
1	0.75	4	5.0
1.5	1.1	5	6.25
2	1.5	7.5	9.4
3	2.2	10	12.5
5	3.7	15	18.75
7.5	5.5	20	25.0
10	7.5	30	37.5
15	11	40	50
20	15	60	75
25	18.5	75	94
30	22	100	125
40	30	100	125
50	37	150	188
60	45	175	220
75	55	250	313
100	75	300	375
125	93	370	469
150	110	450	563
175	130	525	656
200	150	600	750
250	185	750	950
300	220	900	1125
335	250	1000	1250
400	300	1200	1500
470	350	1410	1760
540	400	1620	2025

Effects of Torque

While starting a submersible pump, ensure the pump, delivery pipe, and other parts of the support system can handle the torque developed by the motor. Most pumps rotate in the direction that causes unscrewing torque on right-handed threaded pipe or pump stages.

Ensure all parts of the pump support system can repeatedly withstand the maximum torque without loosening or breaking. Unscrewing joints will break electrical cable and may cause loss of the pump-motor unit.

To safely withstand maximum unscrewing torques with a minimum safety factor of 1.5, tighten all threaded joints to at least 10 lb-ft per motor horsepower. If necessary, like in shallower settings, tack or strap weld pipe joints on high horsepower pumps.

Table 4. Torque Required Examples

Motor Rating		Minimum Safe Torque-Load (lb-ft)
HP	KW	
1 & Less	0.75 & Less	10
20	15	200
75	55	750
200	150	2000
300	220	3000
540	400	5400

Check Valve Use

Check valves hold pressure in the system when the pump stops.

- Always use at least one positive-sealing check valve in submersible pump installations.
- If the pump does not have a built-in check valve, install a line check valve in the discharge line within 25 feet of the pump and below the drawdown level of the water supply.
- For deeper settings, install check valves per the manufacturer's recommendations.
- Do not use more than the recommended number of check valves.
- Never use swing type check valves with submersible motors/pumps.
- Internal pump check valves or spring-loaded check valves close quickly and help eliminate water hammer.

Follow this guide to diagnose and correct check valve related conditions.

Table 5.

Condition	Definition	Resulting Problems	Possible Cause	Corrective Action
Backspin	The water in the drop pipe and the water in the system flows down the discharge pipe when the motor stops.	<ul style="list-style-type: none"> • Excessive force is placed across the pump-motor assembly. • The pump rotates in a reverse direction. • Impeller damage, motor or pump shaft breakage, excessive bearing wear, etc. 	<ul style="list-style-type: none"> • No check valve • Failed check valve 	<ul style="list-style-type: none"> • Install a positive sealing check valve. • Never start the motor while it is backspinning.
Upthrust	The unit starts under a zero head condition causing an uplifting or upthrust on the impeller-shaft assembly in the pump. This upward movement carries across the pump-motor coupling and creates an upthrust condition in the motor.	<ul style="list-style-type: none"> • Premature failure of the pump and motor 	<ul style="list-style-type: none"> • No check valve • Leaking check valve • Drilled check valve 	<ul style="list-style-type: none"> • Install a positive sealing check valve.

MOTOR APPLICATION
Drawdown Seals

Table 5 (continued)

Condition	Definition	Resulting Problems	Possible Cause	Corrective Action
Water Hammer	On the next pump start, water moving at very high velocity fills the void and strikes the closed check valve and the stationary water in the pipe above it, causing a hydraulic shock. Water hammer can often be heard or felt.	<ul style="list-style-type: none"> • Split pipes • Broken joints • Pump/motor damage 	<ul style="list-style-type: none"> • A swing type check valve is used, causing a slower reaction time. • The lowest check valve is more than 30 feet above the standing (lowest static) water level. • A lower check valve leads, and the above check valve holds, creating a vacuum in the discharge piping. 	<ul style="list-style-type: none"> • Shut down the system, and contact the pump installer to correct the problem.
Variable Flow Conditions	Most standard spring-loaded check valves are not designed for the variable flow conditions that occur in a VFD controlled pump.	<ul style="list-style-type: none"> • Premature wear • Noisy conditions that transfer through the system piping 	<ul style="list-style-type: none"> • The check valve is not VFD compatible. 	<ul style="list-style-type: none"> • Use only check valves that are specifically designed for variable flow conditions, typically marked as “VFD compatible”.

Drawdown Seals

Drawdown seals are often used to increase well production by preventing water level drop in a low water well.

However, required motor operating temperatures are based on surrounding pressures equal to or greater than atmospheric pressure.

Do not use drawdown seals because the suction created can be lower than atmospheric pressure.

Well Applications

Franklin Electric submersible motors are designed to operate with a cooling flow of water over and around the full length of the motor.

The conditions requiring a flow inducer sleeve are:

- The pump installation does not provide the [“Required Cooling Flow” on page 9](#).
- Well diameter is too large to meet [“Required Cooling Flow” on page 9](#).
- Pump is in an open body of water.
- Pump is in a rock well or below the well casing.
- The well is “top-feeding” (cascading).
- Pump is set in or below screens or perforations.

Water Temperature and Flow

Franklin Electric's standard submersible motors, except Hi-Temp designs, are designed to operate maximum service factor horsepower in water up to 86 °F (30 °C). For example, a flow of 0.25 ft/s for 4-inch motors rated 3 hp and higher, 0.5 ft/s for 6-inch and 8-inch motors, and 1.5 ft/s for 10-inch and 12-inch motors is required for proper cooling. ["Required Cooling Flow" on page 9](#) shows minimum flow rates, in gpm, for various well diameters and motor sizes.

If a standard motor is operated in water over 86 °F (30 °C), increase water flow past the motor to maintain safe motor operating temperatures. See ["Hot Water Applications \(Standard Motors\)" on page 10](#).

NOTE: Small 4-inch motors (2 hp & smaller) do not have a required minimum flow, except that flow must be greater than zero.

Required Cooling Flow

Use this formula to calculate flow velocity past motor.

Figure 1.

$fps = \frac{gpm \times .409}{ID^2 - OD^2}$	fps = feet per second gpm = gallons per minute ID = internal diameter (in inches) of casing or sleeve OD = outside diameter (in inches) of the motor .409 is a constant used because of the various units of measurement (inches, feet, meters, etc.)
---	---

Table 6. Minimum gpm required for motor cooling in water up to 86 °F (30 °C)

Casing or Sleeve ID Inches (mm)	Cooling Flow by Motor Type GPM (LPM)						
	4-inch (3-10 hp) 0.25 ft (7.62 cm) per sec	6-inch 5-60 hp encapsulated 6-inch < 40 hp Magforce 0.50 ft (15.24 cm) per sec	6-inch MagForce ≥ 40 hp 1.6 ft (48.76 cm) per sec	8-inch encapsulated 0.50 ft (15.24 cm) per sec	8-inch MagForce 1.5 ft (45.72 cm) per sec	10-inch 1.6 ft (48.76 cm) per sec	12-inch 1.6 ft (48.76 cm) per sec
4 (102)	1.2 (4.5)	-	-	-	-	-	-
5 (127)	7 (25.3)	-	-	-	-	-	-
6 (152)	13 (51)	8 (30)	25 (95)	-	-	-	-
7 (178)	21 (81)	24 (90)	76 (287)	-	-	-	-
8 (203)	31 (116)	42 (159)	135 (510)	6 (22)	17 (65)	-	-
10 (254)	53 (199)	86 (326)	275 (1043)	50 (188)	149 (565)	56 (214)	-
12(305)	79 (301)	140 (529)	448 (1694)	104 (392)	311 (1176)	229 (865)	67 (255)
14 (356)	111 (421)	203 (770)	651 (2464)	167 (633)	501 (1898)	432 (1635)	271 (1025)
16 (406)	148 (560)	277 (1048)	886 (3353)	240 (910)	721 (2731)	667 (2524)	505 (1913)

MOTOR APPLICATION
Hot Water Applications (Standard Motors)

Flow Inducer Sleeve

If the flow rate is less than specified, then use a flow inducer sleeve. A flow sleeve is always required in an open body of water.

EXAMPLE: A 6-inch motor and pump that delivers 60 gpm will be installed in a 10 inch well.

As shown in [“Required Cooling Flow” on page 9](#), 90 gpm is required to maintain proper cooling. In this case adding an 8-inch or smaller flow sleeve provides the required cooling.

1. Worm gear clamps
2. Intake
3. Flow inducer sleeve

NOTE: Ensure flow sleeve covers the entire motor.

4. Submersible Motor
5. Centering bolt

NOTE: Locate centering bolts on the motor casting. Do not put on stator shell.

6. Motor casting
7. Saw cuts
8. Notch out (for cable guards)
9. Lock nuts (inside sleeve)
10. Centering bolt hole

NOTE: Three centering bolt holes are recommended.

Figure 2.

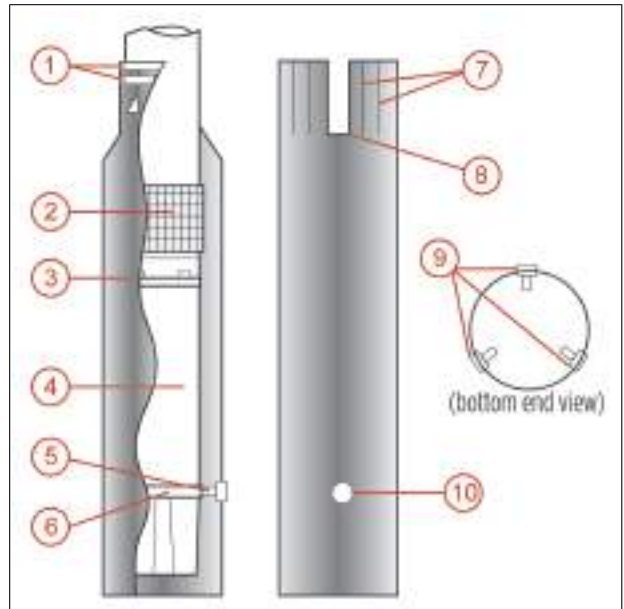

Hot Water Applications (Standard Motors)

Franklin Electric offers a line of Hi-Temp motors which are designed to operate in water with various temperatures up to 194 °F (90 °C) without increased flow.

- When a standard, 4-inch pump-motor operates in water hotter than 86 °F (30 °C), a flow rate of at least 3 ft/s is required. See [“Table 7” on page 10](#)
- When selecting the motor to drive a pump in over 86 °F (30 °C) water, de-rate the motor horsepower per [“Table 8” on page 10](#).

NOTE: If necessary, add a flow sleeve.

Table 7. 3 ft per second flow

Casting or Sleeve ID Inches (mm)	4-inch motor GPM (LPM)
4 (102)	15 (57)
5 (127)	80 (303)
6 (152)	106 (606)

Table 8. 4-inch Motors 1/3 – 5 hp

Water Temperature	Approximate Allowable % of Maximum Nameplate Amps
95 °F (35 °C)	100%
104 °F (40 °C)	100%
113 °F (45 °C)	100%
122 °F (50 °C)	100%

Table 8 4-inch Motors 1/3 — 5 hp (continued)

Water Temperature	Approximate Allowable % of Maximum Nameplate Amps
130 °F (55 °C)	90%
140 °F (60 °C)	80%

Head Loss

Head loss is a loss of pump performance and output due to friction inside a pipe, well casing or flow sleeve. If you keep the water velocity moving past the motor to less than 10 ft per second, head loss is typically not a problem. Refer to Cooling Flow formula in [“Formulas” on page 143](#).

Equipment Grounding

WARNING



Contact with hazardous voltage could result in death or serious injury.

- Serious or fatal electrical shock may result from failure to connect the motor, control enclosures, metal plumbing, and all other metal near the motor or cable to the power supply ground terminal using wire no smaller than motor cable wires.

Safety is the primary purpose of grounding the metal drop pipe and/or metal well casing in an installation. Grounding limits the voltage between nonelectrical (exposed metal) parts of the system and ground, thus minimizing dangerous shock hazards.

- Use wire at least the size of the motor cable wires to provide adequate current-carrying capability for any ground fault that might occur. Use this wire to provide a low resistance path to ground, ensuring that the current to ground will be large enough to trip any over-current device designed to detect faults (such as a ground fault circuit interrupter [GFCI]).
- Normally, the ground wire to the motor provides the primary path back to the power supply ground for any ground fault. However, there are conditions where the ground wire connection can become compromised. For example, when the water in the well is abnormally corrosive or aggressive, a grounded metal drop pipe or casing becomes the primary path to ground.
- When an installation has abnormally corrosive water and the drop pipe or casing is plastic, use a GFCI with a 10 mA set-point. In this case, route the motor ground wire through the current-sensing device along with the motor power leads. Wired this way, the GFCI will trip only when a ground fault has occurred and the motor ground wire is no longer functional.

IMPORTANT: Installations that use plastic drop pipes and/or casings require taking further steps to ensure the water column itself does not become the conductive path to ground.

Grounding Control Boxes and Panels

WARNING



High voltages capable of causing severe injury or death by electrical shock are present in this unit.

- Failure to ground the control frame can result in a serious or fatal electrical shock hazard.

Always connect the control box or panel-grounding terminal to supply ground per the National Electrical Code (NEC) requirements. If the circuit has no grounding conductor and no metal conduit from the box to supply panel, use a wire at least as large as line conductors. Connect this wire from the grounding terminal to the electrical supply ground, per NEC requirements.

Single-Phase Motors

2-Wire Motor Solid State Controls

 **CAUTION**

Risk of bodily injury, electric shock, or property damage.

- Restarting the motor within 5 seconds after power is removed may cause the motor overload to trip.

BIAC Switch Operation

- When power is applied, the bi-metal switch contacts are closed, so the triac is conducting and energizes the start winding.
- As rpm increases, the voltage in the sensor coil generates heat in the bi-metal strip.
- The bi-metal strip bends and opens the switch circuit, removing the start winding.
- The motor continues to run on the main winding alone.
- Approximately 5 seconds after power is removed from the motor, the bi-metal strip cools sufficiently to return to its closed position.
- The motor is ready for the next start cycle.

NOTE: If the motor speed drops during operation, the lowered voltage in the sensor coil allows the bi-metal contacts to close and bring the motor back to operating speed.

Rapid Cycling

The BIAC starting switch will reset within approximately 5 seconds after the motor is stopped. If an attempt is made to restart the motor before the starting switch has reset, the motor may not start; however, there will be current in the main winding until the overload protector interrupts the circuit. The time for the protector to reset is longer than the reset of the starting switch. Therefore, the start switch will have closed and the motor will operate.

A waterlogged tank condition causes fast cycling. When this condition occurs, the user will be alerted to the problem during the off time (overload reset time) because the pressure will drop drastically. Correct this condition to prevent nuisance tripping of the overload protector.

Bound Pump (Sand-locked)

When the motor is not free to turn, as with a sandlocked pump, the BIAC switch creates a "reverse impact torque" in the motor in either direction. Once the sand is dislodged, the motor will start and operate in the correct direction.

3-Wire Control Boxes

NOTICE

Risk of damage to equipment.

- The control box and motor are two pieces of one assembly. Be certain that the control box and motor hp and voltage match. Since a motor is designed to operate with a control box from the same manufacturer, we can promise warranty coverage only when a Franklin control box is used with a Franklin motor.

Single-phase three-wire submersible motors require the use of control boxes. Operation of motors without control boxes or with incorrect boxes can result in motor failure and voids warranty.

Control boxes contain starting capacitors, a starting relay, and, in some sizes, overload protectors, running capacitors, and contactors.

Ratings through 1 hp may use either a Franklin Electric solid state QD or a potential (voltage) type starting relay, while larger ratings use potential relays.

QD Relays (Solid State)

There are two elements in the relay: a reed switch and a triac. The reed switch consists of two tiny rectangular blade-type contacts, which bend under magnetic flux. It is hermetically sealed in glass and is located within a coil that conducts line current.

When power is supplied to the control box:

- The main winding current passing through the coil immediately closes the reed switch contacts.
- The triac turns on, supplying voltage to the start winding.
- The motor starts.
- The QD relay operates, interacting between the triac, reed switch, and motor windings.
- The solid state switch senses motor speed through the changing phase relationship between start winding current and line current.
- As the motor approaches running speed, the phase angle between the start current and the line current becomes nearly in phase.
- The reed switch contacts open.
- The triac turns off, removing voltage from the start winding.
- The motor continues to run on the main winding only.
- The QD relay is ready for the next starting cycle.

Potential (Voltage) Relays

Potential relays have normally closed contacts.

- When power is applied, the start and main motor windings are energized.
- The motor starts.
- The voltage across the start winding is relatively low and not enough to open the contacts of the relay.
- As the motor accelerates, the increasing voltage across the start winding (and the relay coil) opens the relay contacts.
- The starting circuit opens.
- The motor continues to run on the main winding alone, or the main plus run capacitor circuit.

After the motor is started the relay contacts remain open.

MOTOR APPLICATION

Single-Phase Motors

Auxiliary Running Capacitors

A submersible pump system itself is normally not a source of problem noise. However, sometimes the system tolerances come together to create an audible noise. Changing any of the system features will often reduce or eliminate this noise. Adding run capacitors is one way to eliminate system noise.

1. Connect added capacitors across "Red" and "Black" control box terminals, in parallel with any existing running capacitors.
2. Mount the additional capacitor(s) in an auxiliary box.

NOTE: Although motor amps decrease when auxiliary run capacitance is added, the load on the motor does not. If a motor is overloaded with normal capacitance, it will still be overloaded with auxiliary run capacitance, even though motor amps may be within nameplate values.

Auxiliary Capacitor Sizing

NOTE: This table includes maximum SF amps normally in each lead with the auxiliary capacitor.

Table 9.

Motor Rating		Normal Running Capacitor(s) Microfarad (MFD)	Auxiliary Running Capacitors for Noise Reduction				Maximum Amps with Run Capacitor			
HP	Volts		MFD	Min. Volts	Part Number	Qty	Yellow	Black	Red	
1/2	115	0	60 *	370	155327101	2	8.4	7.0	4.0	
1/2	230		15 *		155328101	1	4.2	3.5	2.0	
3/4			20 *		155328103		5.8	5.0	2.5	
1			25 *		155328101		7.1	5.6	3.4	
1.5		15	155328102	9.3	7.5		4.4			
2		20	155328101	11.2	9.2		3.8			
3		45	-	-	-		17.0	12.6	6.0	
5		80	-	-	-		27.5	19.1	10.8	
7.5		45	45	370	155327101		37.0	32.0	11.3	
					155328101					
					155327101					
10	70	30	-	-	-	49.0	42.0	13.0		
15	135	-	-	-	-	75.0	62.5	16.9		

NOTE: *Do not add running capacitors to 1/3 through 1 hp control boxes that use solid state switches or QD relays. Adding capacitors will cause switch failure. If the control box is converted to use a voltage relay, the specified running capacitance can be added.

Buck-Boost Transformers

When the available power supply voltage is not within the proper range, a buck-boost transformer is often used to adjust voltage to match the motor. The most common application with submersible motors is boosting a 208 volt supply to use a standard 230 volt single-phase submersible motor and control. While tables giving a wide range of voltage boost or buck are published by transformer manufacturers, the following table shows Franklin's recommendations. The values given below are based on boosting the voltage 10% and show the minimum kVA needed as well as the common transformer kVA available.

Buck-Boost Transformer Sizing

Table 10.

kVA	Motor HP										
	1/3	1/2	3/4	1	1.5	2	3	5	7.5	10	15
Load kVA	1.02	1.36	1.84	2.21	2.65	3.04	3.91	6.33	9.66	11.70	16.60
Minimum XFMR kVA	0.11	0.14	0.19	0.22	0.27	0.31	0.40	0.64	0.97	1.20	1.70
Standard XFMR kVA	0.25	0.25	0.25	0.25	0.50	0.50	0.50	0.75	1.00	1.50	2.00

NOTE: Buck-Boost transformers are power transformers, not control transformers. They may also be used to lower voltage when the available power supply voltage is too high.

Three-Phase Motors

Power Connections and Transformers

When connecting transformers, the utility companies have many different options. Open or Closed Wye, Open or Closed Delta, Center Tap and Corner grounded Delta are examples. Three transformer Closed systems are recommended.

Even if the supply appears to be full three-phase power, voltage measurements can vary depending on the transformer's internal connections.

Figures 3 and 4 are examples of line-to-line and line-to-ground voltages.

Figure 3.

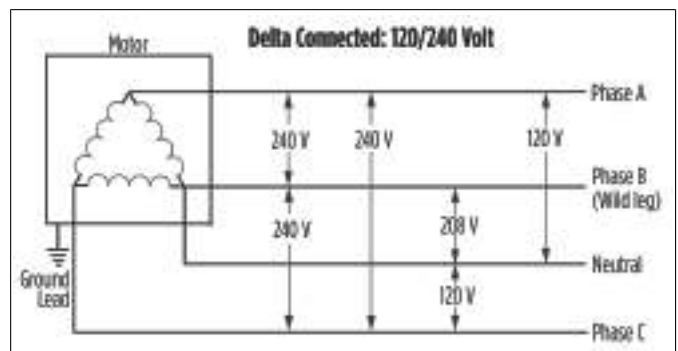
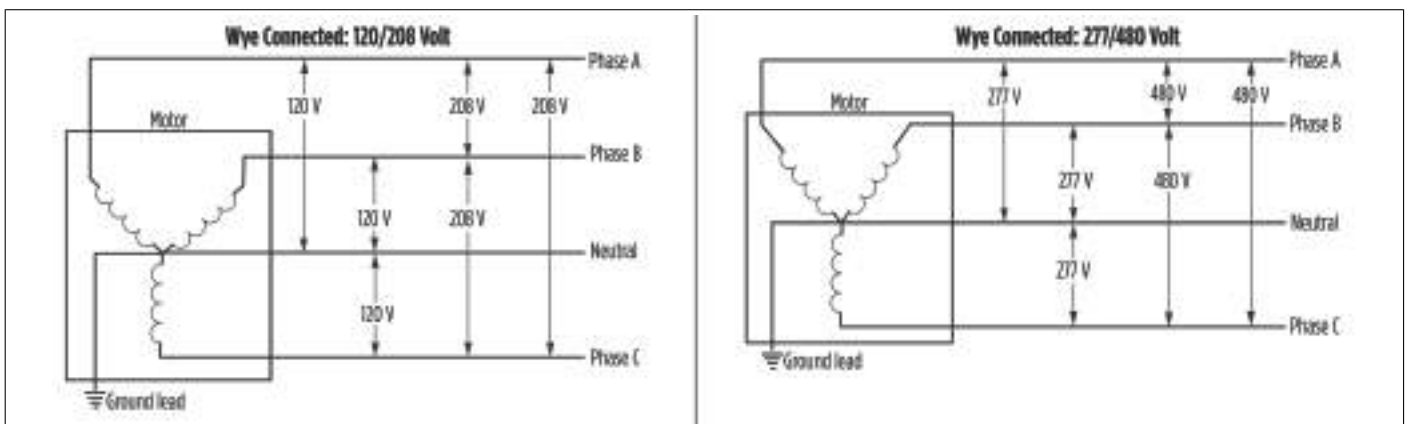

Figure 4.



MOTOR APPLICATION

Three-Phase Motors

Power Factor Correction

In some installations, power supply limitations require an increase to the power factor of a submersible motor. [“kVAR Required” on page 16](#) lists the capacitive kVAR required to increase the power factor of large Franklin Electric three-phase submersible motors to the approximate values shown at maximum input loading.

Connect capacitors on the line side of the overload relay or overload protection will be lost.

kVAR Required

Table 11.

Motor		kVAR		
HP	KW	0.90 PF	0.95 PF	1.00 PF
5	3.7	1.2	2.1	4.0
7.5	5.5	1.7	3.1	6.0
10	7.5	1.5	3.3	7.0
15	11	2.2	4.7	10.0
20	15	1.7	5.0	12.0
25	18.5	2.1	6.2	15.0
30	22	2.5	7.4	18.0
40	30	4.5	11.0	24.0
50	37	7.1	15.0	32.0
60	45	8.4	18.0	38.0
75	55	6.3	18.0	43.0
100	75	11.0	27.0	60.0
125	93	17.0	36.0	77.0
150	110	20.0	42.0	90.0
175	130	9.6	36.0	93.0
200	150	16.0	46.0	110.0
250	185	15.4	48.8	133.2
300	220	25.2	67.1	172.8
335	250	39.3	84.8	199.7
400	300	8.5	61.0	193.6
470	350	20.1	83.9	244.8
540	400	33.9	107.3	292.7

NOTE: Values listed are total required (not per phase).

Phase Converters

Many different types of phase converters are available. Each generates three-phase power from a single-phase power line.

In all phase converters, the voltage balance is critical to current balance. Although some phase converters may be well-balanced at one point on the system-operating curve, submersible pumping systems often operate at differing points on the curve as water levels and operating pressures fluctuate. Other converters may be well-balanced at varying loads, but their output may vary widely with fluctuations in the input voltage.

Follow these established guidelines for warranties of submersible installations with a phase converter:

1. Limit pump loading to rated horsepower. Do not load into motor service factor.
2. Maintain at least 3 ft/s flow past the motor. Use a flow sleeve when necessary.
3. Use time delay fuses or circuit breakers in pump panel. Standard fuses or circuit breakers do not provide secondary motor protection.
4. Do not use SubMonitor with electronic solid state or electro mechanical phase converters.
5. Do not allow current unbalance to exceed 10%.

Reduced Voltage Starters (RVS)

CAUTION

Risk of bodily injury, electric shock, or property damage.

- Do not use a Reduced Voltage Starter with a minimum sized generator. Both items drop the output voltage and combining these items causes the potential for severe motor damage and equipment failure due to low voltage.

All Franklin Electric three-phase submersible motors are suitable for full-voltage starting. Under this condition the motor speed goes from zero to full speed within a half second or less. The motor current goes from zero to locked rotor amps, then drops to running amps at full speed. This may dim lights, cause momentary voltage dips to other electrical equipment, and shock power distribution transformers.

Use a RVS:

- When the power company requires one to limit voltage drop.
- To reduce motor starting torque thus reducing the stress on shafts, couplings, and discharge piping.
- To slow the rapid acceleration of the water on start-up to help control upthrust and water hammer.

If the maximum recommended cable length is used, an RVS may not be required. In this case, there is a 5% voltage drop in the cable at running amps. This causes about 20% reduction in starting current and about 36% reduction in starting torque compared to having rated voltage at the motor.

Three-Lead Motors: Use an autotransformer or solid-state RVS to soft-start standard three-phase motors.

When using autotransformer starters, supply the motor with at least 55% of rated voltage to ensure adequate starting torque. Most autotransformer starters have 65% and 80% taps. Setting the taps on these starters depends on the percentage of the maximum allowable cable length used in the system.

- If the cable length is less than 50% of maximum allowable, use either the 65% or the 80% taps.
- If the cable length is more than 50% of maximum allowable, use the 80% tap.

Six-Lead Motors: Wye-Delta starters are used with six-lead Wye-Delta motors. All Franklin Electric 6-inch and 8-inch three-phase motors are available in six-lead Wye-Delta construction. Consult the factory for details and availability. Do not use part winding starters because they are not compatible with Franklin Electric submersible motors.

Do not use Wye-Delta starters of the open-transition type that momentarily interrupt power during the starting cycle. Instead use closed-transition starters which do not interrupt power during the start cycle.

MOTOR APPLICATION

Three-Phase Motors

An RVS has settings for acceleration ramp time that are typically preset to 30 seconds. Adjust them so the motor is at full voltage within three seconds maximum to prevent excessive radial and thrust bearing wear.

If using SubMonitor or SubMonitor-Plus, set the acceleration time to two seconds maximum because of the 3 second reaction time of the SubMonitor or SubMonitor-Plus.

Solid-state starters (soft starts) may not be compatible with SubMonitor/SubMonitor-Plus. However, in some cases a bypass contactor has been used. Consult the factory for details.

During shutdown, remove the power to allow the pump/motor to coast down. Stopping the motor by ramping down the voltage is possible, but should be limited to three (3) seconds maximum.

Three-Phase Starter Diagrams

Three-phase combination magnetic starters have two distinct circuits: power and control.

The power circuit consists of a circuit breaker or fused line switch, contacts, and overload heaters connecting incoming power lines L1, L2, L3 and the three-phase motor.

The control circuit consists of the magnetic coil, overload contacts, and a control device (e.g. a pressure switch).

- When the control device contacts are closed, current flows through the magnetic contactor coil, the contacts close, and power is applied to the motor.
- Hand-Off-Auto switches, start timers, level controls, and other control devices may also be in series in the control circuit.

Line Voltage Control

This is the most common type of control encountered. Ensure the coil matches the line voltage because the coil is connected directly across the power lines L1 and L2.

Figure 5.

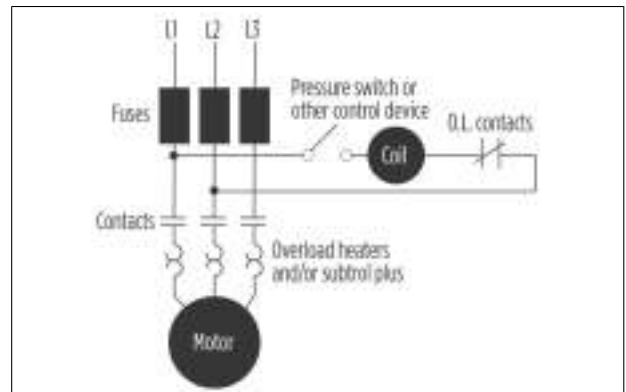

Low Voltage Transformer Control

Use this control to operate push buttons or other control devices at some voltage lower than the motor voltage. Make sure the transformer primary matches the line voltage and the coil voltage matches the secondary voltage of the transformer.

Figure 6.

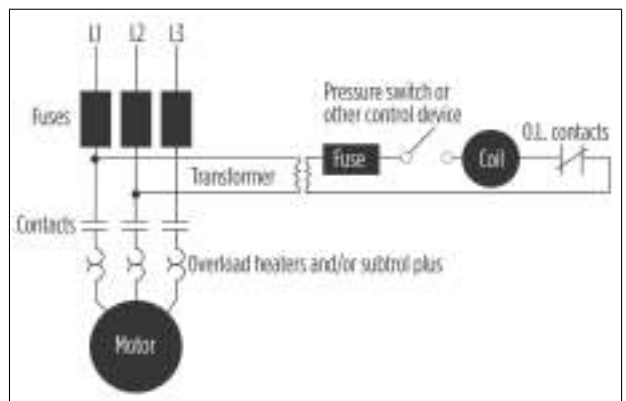

External Voltage Controls

Connect to a separate control voltage source to obtain control of a power circuit by a lower circuit voltage. Ensure the coil rating matches the control voltage source.

Figure 7.

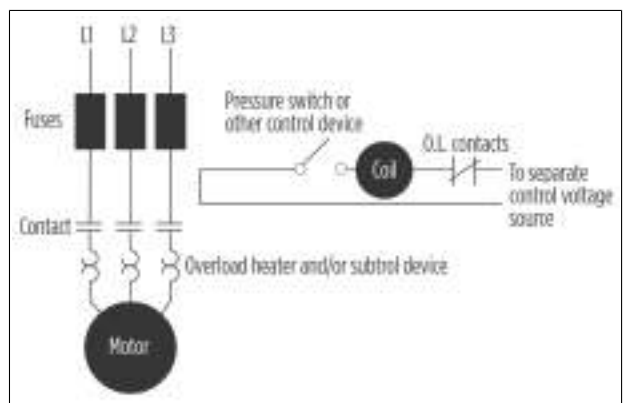

MOTOR APPLICATION

Three-Phase Motors

Overload Protection of Three-Phase Submersible Motors

NOTE: Class 10 protection required

Special overload protection is required for submersible motors. To provide sufficient protection against overloading and locked rotor conditions, ensure the relay meets the following characteristics:

- Trips within 10 seconds or less at 500% of set current.
- Ultimately trips at 125% of set current.
- Protects against single phasing.
- Temperature compensates to avoid nuisance tripping.

Make sure the trip points meet with the relay at -10 °C room ambient and 50 °C temperatures.

Obtain specific overload information directly from the manufacturer's catalog. This information is available from a Time/Current curve as shown.

Figure 8.

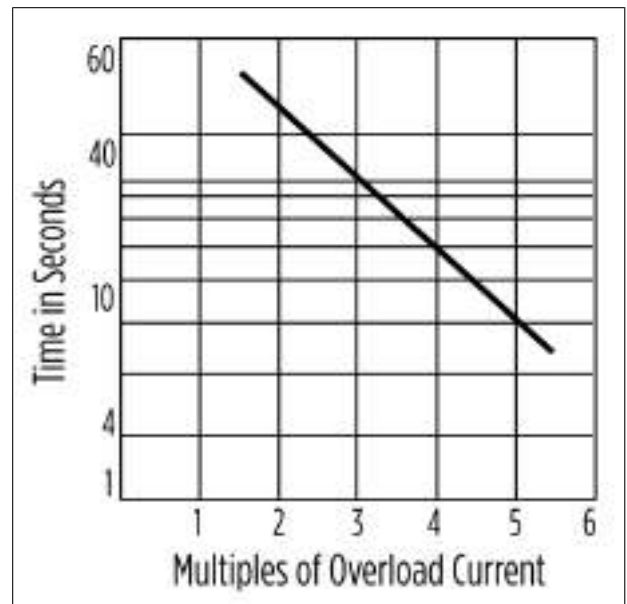

Three-Phase Power Unbalance

Figure 9.

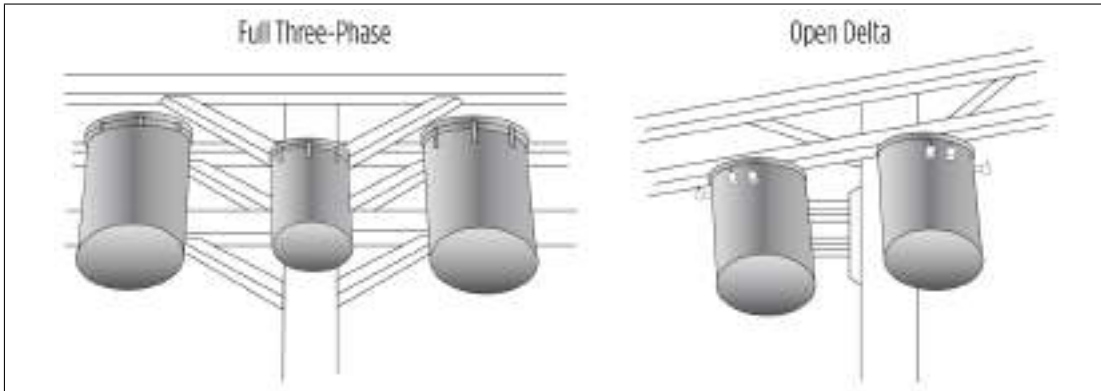

Use a full three-phase supply for all three-phase motors. This supply consists of three individual transformers or one three-phase transformer.

Open Delta or Wye connections that use only two transformers are more likely to cause problems, such as poor performance, overload tripping, or early motor failure due to current unbalance.

Ensure transformer rating are no smaller than listed in [“Transformer Capacity” on page 4](#) for supply power to the motor alone.

Motor Rotation

Normal rotation is counterclockwise (CCW) viewing the shaft end.

CCW Rotation Lead Phase Designation

- Phase 1 or "A" - Black, T1, or U1
- Phase 2 or "B" - Yellow, T2, or V1
- Phase 3 or "C" - Red, T3, or W1

NOTE: Phase 1, 2, and 3 may not be L1, L2, and L3

Establish correct motor rotation by running the motor in both directions. The rotation that gives the most water flow is typically the correct rotation. Change rotation by interchanging any two of the three motor leads.

Current Unbalance

- After correct rotation has been established, check the current in each of the three motor leads and calculate the current unbalance:
 - Add the three line amps values together.
 - $\text{Sum} \div 3 = \text{average current}$
 - Pick the amp value that is furthest from the average current (either high or low).
 - Average — this amp value (furthest from average)
 - $\text{Difference} \div \text{average} = \text{result}$
 $\text{Result} \times 100 = \text{percent of unbalance.}$
 - If the current unbalance is 2% or less, leave the leads as connected.
 - If the current unbalance is more than 2%, check current readings on each leg using each of three possible hook-ups. Roll the motor leads across the starter in the same direction to prevent motor reversal.

Figure 10.

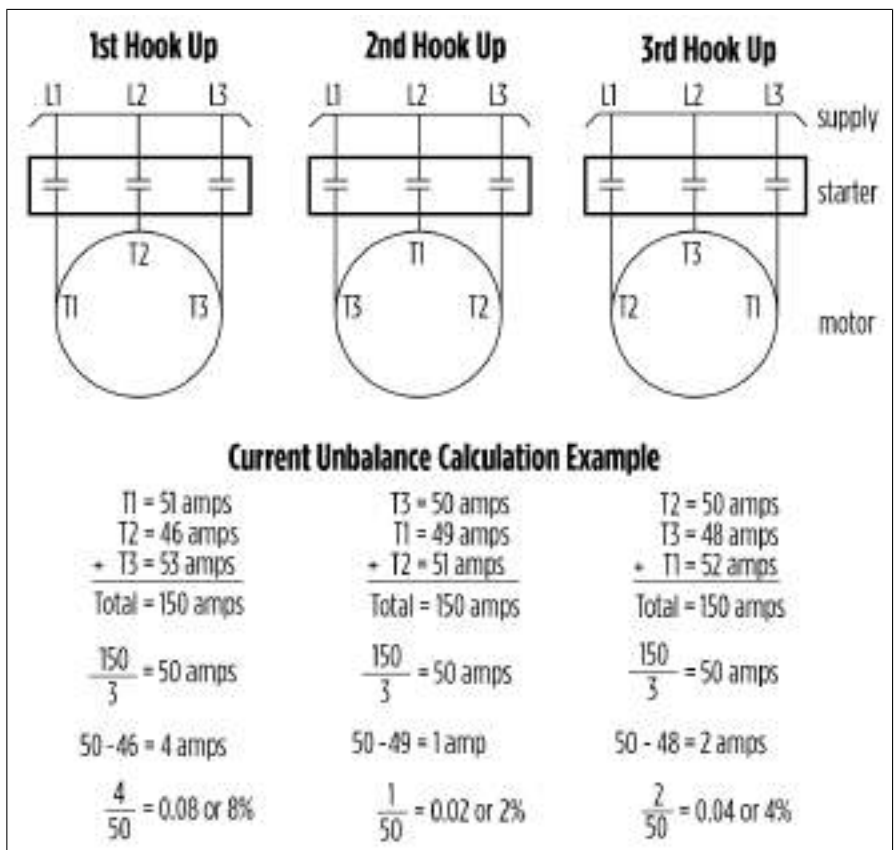

- Correct any unbalance that exceeds 5% max amp load or 10% rated input load.
 - If the unbalance cannot be corrected by rolling leads, locate and correct the source of the unbalance.
 - If, on the three possible hookups, the leg farthest from the average stays on the same power lead, most of the unbalance is coming from the "power side" of the system.
 - If the reading farthest from average moves with the same motor lead, the primary source of unbalance is on the "motor side" of the starter. In this instance, consider a damaged cable, leaking splice, poor connection, or faulty motor winding.

MOTOR APPLICATION

Three-Phase Motors

Three-Phase Motor Lead Identification

⚠ WARNING

Risk of severe injury or death.

- When installing 6-lead motors extra care must be used to ensure lead identification at the surface. Leads must be marked and connected per diagram. Motor leads are not connected red to red, yellow to yellow, etc.

Six-Lead Motors Line Connections

- T1-U1 (BLK)*
- T2-V1 (YEL)*
- T3-W1 (RED)*
- T4-U2 (BLK)
- T5-V2 (YEL)
- T6-W2 (RED)
- Check valve or pipe plug on right side facing motor shaft

NOTE: *Only leads T1-T3 are provided in 3-lead (dol) motors.

Figure 11.

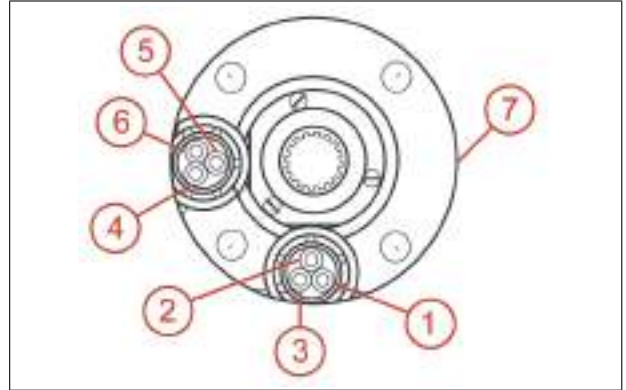

90° Lead Spacing

NOTE: Each motor lead is numbered with two markers, one near each end. To reverse rotation, interchange any two line connections.

Figure 12.

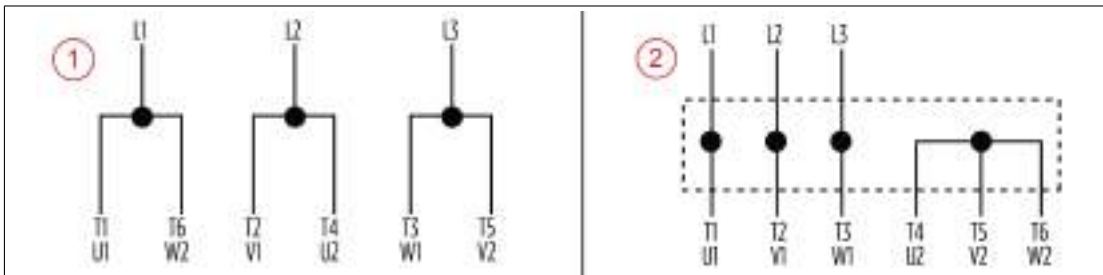

- Connections for across-the-line starting, running, and any reduced voltage starting except WYE-DELTA type starters
- WYE-DELTA starters connect the motor as shown below during starting, then change to the running connection shown in number 1.

Inline Booster Pump Systems

Franklin Electric offers different types of motors for non-vertical applications that must be applied per the guidelines in [“Design and Operational Requirements” on page 23](#).

For all applications where the motor is applied in a sealed system, a Submersible Motor Booster Installation Record (Form 3655) or its equivalent must be completed at start-up and received by Franklin Electric within 60 days. A sealed system is one where the motor and pump intake are mounted in a sleeve and the water feeding the pump intake is not open to the atmosphere.

1. Booster motors:
 - are specifically designed for booster applications.
 - are the best choice for sealed Reverse Osmosis applications.
 - bring additional value and durability to booster module systems.
 - are only available to OEMs or Distributors who have demonstrated capability in Booster Module systems design and operation and adhere to AIM requirements.
2. Hi-Temp motors:
 - have many of the internal design features of the Booster motor.
 - allow for higher temperature handling.
 - provide greater abrasion resistance with the Sand Fighter sealing system.

NOTE: These conditions often occur in open atmosphere applications such as lakes and ponds.

3. Standard Vertical Water Well (40–125 hp) motors:
 - can be adapted to non-vertical applications when applied per [“Design and Operational Requirements” on page 23](#).
 - will be more sensitive to application variances than the other two designs.

Design and Operational Requirements

Non-Vertical Operation

Vertical Shaft-up (0°) to Horizontal (90°) operation is acceptable as long as the pump transmits down-thrust to the motor within 3 seconds after start-up and continuously during operation. However, it is best practice to provide a positive slope whenever possible, even if it is only a few degrees.

Motor, Sleeve, and Pump Support System

- Size the booster sleeve ID according to the motor cooling and pump NPSHR requirements. The support system must support the motor’s weight, prevent motor rotation, and keep the motor and pump aligned.
- The support system must also allow for thermal axial expansion of the motor without creating binding forces.

Motor Support Points

- A minimum of two support points are required on the motor: one in the motor/pump flange connection area and one in the bottom end of the motor area.
- Use the motor castings, not the shell area, as support points.

IMPORTANT: If the support is a full length support and/or has bands in the shell area, they must not restrict heat transfer or deform the shell.

Motor Support Material and Design

- Do not allow the support system to create any areas of cavitation or of reduced flow that is less than the minimum rate in [“Required Cooling Flow” on page 9](#).
- Design the supports to minimize turbulence and vibration and provide stable alignment.
- The support materials and locations must not inhibit the heat transfer away from the motor.

MOTOR APPLICATION

Three-Phase Motors

Motor and Pump Alignment

- The maximum allowable misalignment between the motor, pump, and pump discharge is 0.025 inch per 12 inches of length (2 mm per 1000 mm of length). Measure this in both directions along the assembly using the motor/pump flange connection as the starting point.
- Ensure the booster sleeve and support system are rigid enough to maintain this alignment during assembly, shipping, operation, and maintenance.

Lubrication and Heat Resistance

- The best motor lubrication and heat resistance is obtained with the factory based propylene glycol fill solution. Replace this solution only when an application has deionized (DI) water.
- Permanently stamp the motor shell with a DI closely behind the serial number.

IMPORTANT: The maximum pressure that can be applied to the motor internal components during the removal of the factory fill solution is 7 psi (0.5 bar.)

NOTE: The exchange of the motor fill solution to DI water must be done by an approved Franklin service shop or representative using a vacuum—fill system.

Figure 13.

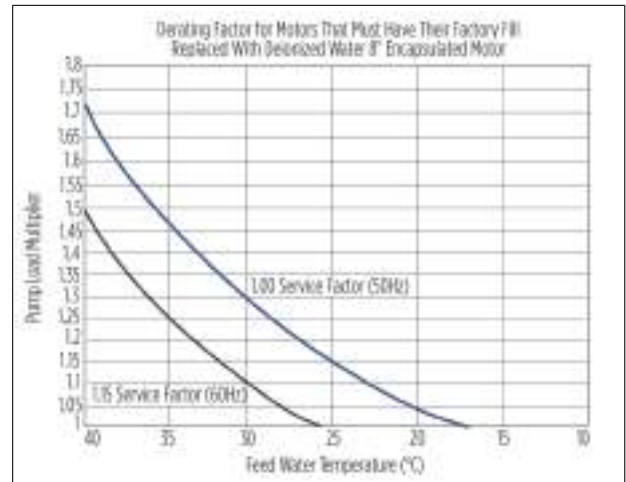

When a deionized water fill is required, derate the motor:

1. Determine maximum feed water temperature that this application will experience.
 - Refer to [“Figure 13” on page 24](#).
 - If the feed water exceeds the maximum ambient of the motor, apply both the DI water derating and a hot water application derating.
2. Determine the Pump Load Multiplier from the appropriate Service Factor curve.

NOTE: Typical 1.15 Service Factor is for 60 Hz ratings and 1.00 Service Factor for 50 Hz ratings.

3. Multiply the Pump Load Requirement times the pump load multiplier number indicated on the vertical axis to determine the Minimum Motor Nameplate Rating.
4. Select a motor with a nameplate equal or higher than the above calculated value.

Motor Alterations - Sand Slinger & Check Valve Plug

- On 6-inch and 8-inch motors, remove the rubber sand slinger located on the shaft.
- If a pipe plug is covering the check valve, remove it.

NOTE: The special Booster motor already has these modifications.

Frequency of Starts

- Refer to [“Frequency of Starts” on page 3](#).

Controls-Soft Starters and VFDs

- Reduced voltage starters and variable speed drives (inverter drives) may be used with Franklin three-phase submersible motors to reduce starting current, upthrust, and mechanical stress during start-up.
- The guidelines for their use with submersible motors are different than with normal air cooled motor applications. Refer to [“Reduced Voltage Starters \(RVS\)” on page 17](#) and [“Variable Frequency Drive Submersible Motor Requirements” on page 28](#) for specific details including required filtering.

Motor Overload Protection

- Submersible motors require properly sized ambient compensated Class 10 quick-trip overloads per [“Overload Protection of Three-Phase Submersible Motors” on page 20](#) to protect the motor.
- Do not use Class 20 or higher overloads.
- Use Franklin Electric’s SubMonitor for all large submersibles because it can sense motor heat without any additional wiring to the motor.
- Applications using Soft Starters with a SubMonitor require a start-up bypass. Consult the factory for details. SubMonitor can not be used in applications using a VFD control.

Motor Surge Protection

- Install properly sized, grounded, and dedicated motor surge arrestors in the supply line of the booster module as close to the motor as possible.
- This is required on all systems including those using soft-starters and variable speed drives (inverter drives).

Wiring

 CAUTION
Risk of bodily injury, electric shock, or property damage.
<ul style="list-style-type: none"> • Franklin’s lead assemblies are only sized for submerged operation in water to the motor nameplate maximum ambient temperature and may overheat and cause failure or serious injury if operated in air.

- Any wiring not submerged must meet applicable national and local wiring codes and match the tables in [“Motor, Cable, & Fuse/Circuit Breaker Reference” on page 49](#).

NOTE: Wire size, wire rating, and insulation temperature rating must be known when determining its suitability to operate in air or conduit. Typically, for a given size and rating, as the insulation temperature rating increases its ability to operate in air or conduit also increases.

Table 12.

Cable Temp. Rating (°C)	Motor Nameplate Rated Amps Full Load	#10 AWG		#8 AWG		#6 AWG		#4 AWG		#2 AWG	
		In Air	In Conduit	In Air	In Conduit	In Air	In Conduit	In Air	In Conduit	In Air	In Conduit
75	3-Lead (DOL)	40A	28A	56A	40A	76A	52A	100A	68A	136A	92A
	6-Lead (Y-Δ)	69A	48A	97A	69A	132A	90A	173A	118A	236A	159A
90	3-Lead (DOL)	44A	32A	64A	44A	84A	60A	112A	76A	152A	104A
	6-Lead (Y-Δ)	76A	55A	111A	76A	145A	104A	194A	132A	263A	180A
125	3-Lead (DOL)	66A	46A	77A	53A	109A	75A	153A	105A	195A	134A
	6-Lead (Y-Δ)	114A	80A	133A	91A	188A	130A	265A	181A	337A	232A

NOTE: Based on 30 °C maximum ambient with cable length of 100 feet or less.

MOTOR APPLICATION

Three-Phase Motors

Check Valves

Use spring-loaded check valves:

- on start-up to minimize motor upthrusting and water hammer
- in multiple booster (parallel) applications to prevent reverse flow

Pressure Relief Valves

Use a pressure relief valve that is selected to ensure that, as the pump approaches shut-off, it never reaches the point that the motor will not have adequate cooling flow past it.

System Purge (Can Flooding)

- Install an air bleeder valve on the booster sleeve so that flooding occurs prior to booster start-up.
- Once flooding is complete, start the booster and bring it up to operating pressure as quickly as possible to minimize the duration of an upthrust condition.

IMPORTANT: Do not allow air to gather in the booster sleeve because this will prevent proper cooling of the motor and permanently damage it.

System Flush – Must Not Spin Pump

- Applications may utilize a low flow flushing operation.
- Flow through the booster sleeve must not spin the pump impellers and the motor shaft.
- Consult the booster pump manufacturer for maximum flow rate through the pump when the motor is not energized.

IMPORTANT: If spinning takes place, the bearing system will be permanently damaged and the motor life shortened.

Open Atmosphere Booster Pump Systems

- When an open booster is placed in an environment that is open to atmospheric pressure, the water level must provide sufficient head pressure to allow the pump to operate above its NPSHR requirement at all times and all seasons.
- Provide adequate inlet pressure prior to booster start-up.

Four Continuous Monitoring System Requirements for Sealed Booster Systems

1. Water Temperature

IMPORTANT: If the inlet temperature exceeds the motor nameplate maximum ambient temperature, shut down the system immediately to prevent permanent motor damage.

- Feed water on each booster must be continuously monitored and not allowed to exceed the motor nameplate maximum ambient temperature at any time.
- If feed water temperatures are expected to be above the allowable temperature, derate the motor.
- See for derating guidelines.
- The high temperature feed water derating is in addition to the exchange to DI water derating if the motor factory fill solution was exchanged to DI water.

2. Inlet Pressure

IMPORTANT: If at any time these pressure requirements are not being met, de-energize the motor immediately to prevent permanent damage to the motor. Once the motor is damaged, it is not immediately noticeable, but progresses and results in a premature motor failure weeks or months after the damage occurred.

- Continuously monitor the inlet pressure on each booster module.
- Ensure the inlet pressure is always positive and higher than the NPSHR (Net Positive Suction Head Requirement) of the pump.
- A minimum of 20 PSIG (1.38 Bar) is required at all times, except for 10 seconds or less when the motor is starting and the system is coming up to pressure. Even during these 10 seconds the pressure must remain positive and be higher than the NPSHR of the pump.
 - PSIG is the actual value displayed on a pressure gauge in the system piping.
 - PSIG is the pressure above the atmospheric conditions.
- Motors that will be exposed to pressure in excess of 500 psi (34.47 Bar) must undergo special high pressure testing. Consult factory for details and availability.

3. Discharge Flow

- Do not allow the flow rate for each pump to drop below the motor minimum cooling flow requirement.

IMPORTANT: If the motor minimum cooling flow requirement is not being met for more than 10 seconds, shut down the system immediately to prevent permanent motor damage.

4. Discharge Pressure

- Monitor the discharge pressure to ensure that a downthrust load toward the motor is present within 3 seconds after start-up and continuously during operation.

IMPORTANT: If the motor discharge pressure is not adequate to meet this requirement, shut down the system immediately to prevent permanent motor damage.

Variable Frequency Drive Submersible Motor Requirements

WARNING



Contact with hazardous voltage could result in death or serious injury.

- There is a potential shock hazard from contact with and/or touching the insulated cables connected to the variable frequency drive output anytime the motor has energy applied.

Franklin Electric's three-phase, encapsulated submersible motors can be used with variable frequency drives (VFDs) when applied within the guidelines below.

Size the VFD for all three-phase, encapsulated submersible motors based on the motor's nameplate maximum amps, not horsepower. Ensure the continuous rated amps of the VFD are equal to or greater than the motor's nameplate maximum amps or the warranty will be void.

Franklin Electric's single-phase, 2- and 3-wire, encapsulated submersible motors can only be used with the appropriate Franklin Electric constant pressure controller.

NOTE: The warranty on Franklin Electric 2-wire motors is void if applied to non-Franklin VFDs.

Output Filter Requirement Test

NOTICE

Risk of damage to equipment.

- An incoming power supply or line-side filter for the drive does not replace the need for additional output filters.

An output filter is required if:

1. The motor nameplate voltage is more than 379 volts.
2. The cable from drive-to-motor is more than 50 ft (15.2 m).

NOTE: More than 99% of the drives applied on water well submersible motors meet the requirements above.

An output filter may be necessary for the motor to be considered for warranty.

Filtering Guidelines

- The drive manufacturer should recommend filters.
- Franklin Electric has a line of VFDs that are specifically designed for Franklin Electric systems. These VFDs are used in the SubDrive constant pressure systems. The Franklin Electric SubDrive systems already have the required additional output filtering installed.
- For other Franklin Electric VFD products, follow the filter requirements as recommended in the product manuals.

VFD Filter Sizing

Be sure to have the following information while ordering a filter.

- VFD model
- Carrier frequency setting
- Motor nameplate voltage
- Motor nameplate max amps
- Cable length from the drive output terminals to the motor
- Motor operating frequency or hertz

Filter & Reactor Types

For submersible applications, typical installations use either a reactor, dV/dt filter, or sine wave filter. While a sine wave filter is generally best, it is not always required.

A resistor-inductor-capacitor (RLC) filter has both a high pass filter and a low pass filter section. These filters are considered the best practice, but a low pass reactor filter is also acceptable in some cases

PWM (Pulse Width Modulated) dV/dt value is either the rate at which voltage is changing with time or how fast the voltage is accelerating.

- This information can be supplied by the drive manufacturer or the manufacturer’s drive specification sheet.
- The dV/dt value cannot be measured with typical field equipment, even when using a true-RMS voltage/amperage multi-meter.

VFD Output Filtering Requirements

For suggestions on dV/dt and sine wave filters:

Table 13.

Motor Voltage Rating (VAC)	Input Voltage (VAC)	Motor Cable Length (ft)	Recommended Output Filter	Recommended VFD Carrier Frequency (kHz)
< 380	<342	—	None	2
> 342 – 575	< 632	< 50		
		50 - 800	dV/dt*	2 - 2.5
		> 800	sine wave**	> 4

NOTE: *MagForce 4-Pole Motors with fundamental frequency up to 120 Hz will require dV/dt filter current derating.

NOTE: **VFD Operating Frequencies greater than 75 Hz may need derating depending on filter manufacturer.

Input Current & Motor Overload Protection

- Set motor input current at the system’s typical operating current when running at nameplate rated voltage and frequency (Hz).
- Set motor overload protection to trip at 115% of the system’s typical operating current.
- Check that motor overload protection trips equal to or faster than NEMA Class 10 motor overload curve requirements. Refer to [“Overload Protection of Three-Phase Submersible Motors” on page 20.](#)

Motor Maximum Load Limits

- Make sure the system never operates above the motor nameplate maximum amps.
- On 50 Hz motors, nameplate full load amps are maximum amps since they have a 1.0 service factor.

Motor Operating Hertz, Cooling Requirements, and Underload Settings

- For three-phase induction submersible motors with large VFD installations, limit the operation to 60 Hz max. Operating at greater than 60 Hz requires special system design considerations.
- Check that the motor never exceeds maximum nameplate amps.
- Ensure the motor never operates below 30 Hz. This is the minimum speed required to provide correct bearing lubrication.
- Make sure the motor’s operating speed always operates so the minimum water flow requirements of 0.5 ft/sec for 6-inch and 8-inch motors and 0.25 ft/sec for 4-inch motors is supplied.
- Select the motor underload protection trip point so minimum flow requirements are always met.

MOTOR APPLICATION

Three-Phase Motors

VFD Frequency of Starts

Keep the starts per day within the recommended numbers shown in [“Frequency of Starts” on page 3](#) to provide the best system life. Large three-phase submersible motors can be started more frequently because in-rush current is typically reduced when used with a properly configured VFD. In all cases a maximum of 200 starts per 24 hour period is recommended.

Starting and Stopping Ramp Settings

- The motor must reach or pass the 30 Hz operating speed within 1 second of the motor being energized. If this does not occur, the motor bearings will be damaged and the motor life reduced.
- The best stopping method is to turn power off followed by a natural coast to stop.
- A controlled stop from 30 Hz to 0 Hz is allowed if the time does not exceed 1 second.

Drive Carrier Frequency

- The carrier frequency is set in the field. The drive normally has a selectable range between 2k and 12k Hz. The higher the carrier frequency setting, the more losses the drive will have which causes heat in the drive; the lower the carrier wave frequency setting, the rougher/poorer the shape of the power curve.
- Set the carrier frequency within the range of 2k to 2.5k Hz for encapsulated submersible motors.

Application Function Setting

If the VFD doesn't have a setting for submersible pump, use a centrifugal pump or propeller fan setting. Centrifugal pumps and fans have similar load characteristics.

VFD Pressure Tank Sizing

- VFD systems only need a small pressure tank to maintain constant pressure, although a larger tank may be used. For proper tank sizing, refer to the VFD manufacturer.
- For generic tank sizing, size the tank volume to be 10 to 20% of the pumps output rating at 60Hz. For example, a system capable of 100 GPM = 10-to-20-Gal tank by volume minimum.

NEMA MG1 Above Ground Motor Standard Comments

Franklin Electric encapsulated submersible motors are not declared inverter duty motors by NEMA MG1 standards because part 31 does not include a section covering encapsulated winding designs. However, these motors can be used with VFDs without warranty concerns so long as Franklin Electric guidelines are followed.

INSTALLATION

Submersible Motor Dimensions for a Standard Water Well

NOTE: Visit franklinwater.com or refer to the catalog for motor lengths and shipping weights.

Figure 14.

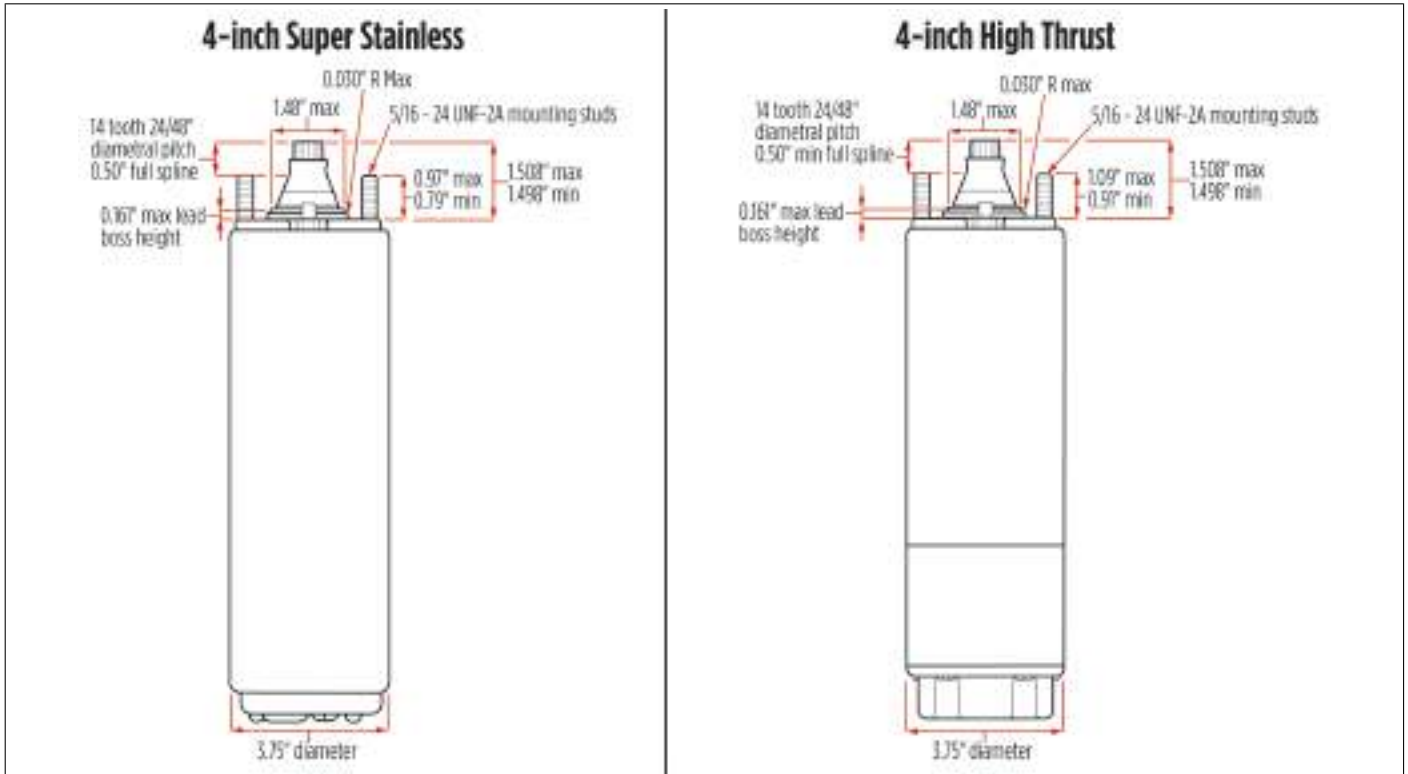

INSTALLATION
Submersible Motor Dimensions for a Standard Water Well

Figure 15.

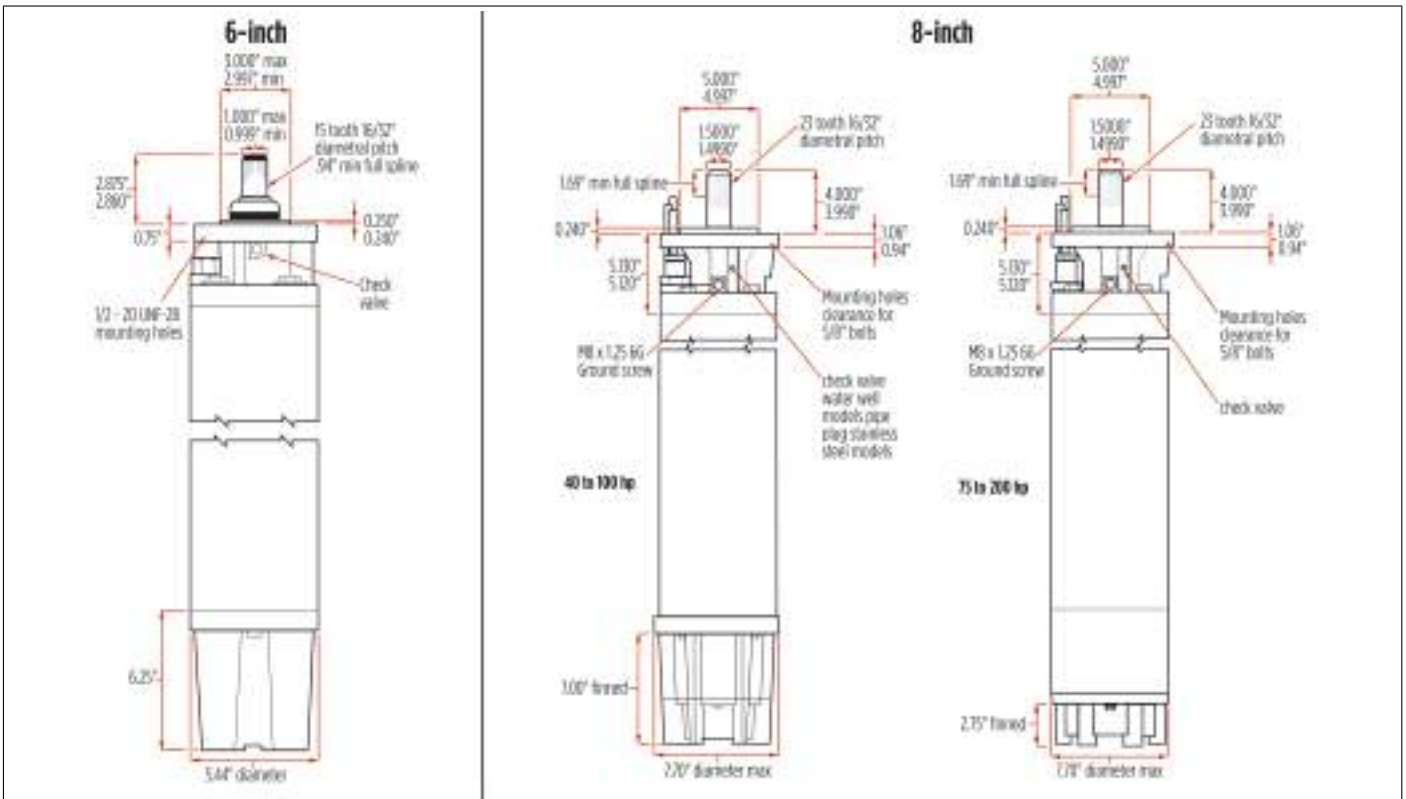
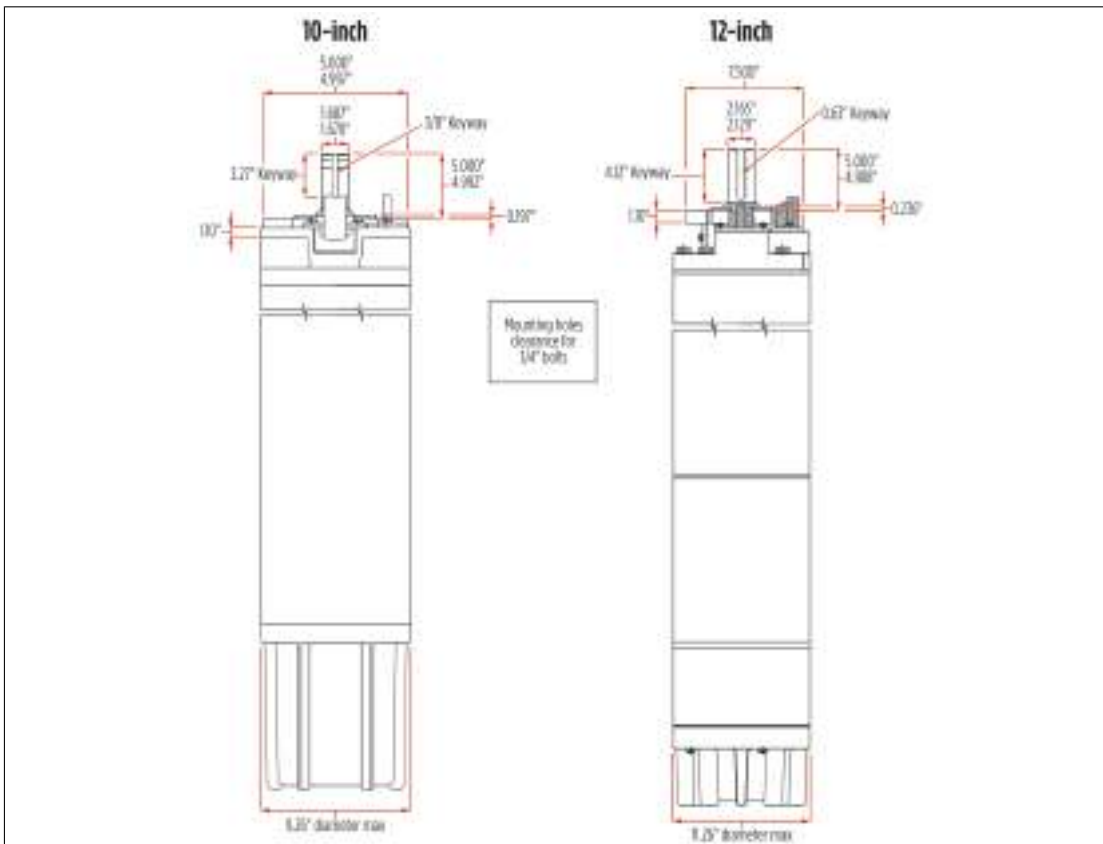

Figure 16.



Submersible Leads and Cables

⚠ CAUTION

Risk of bodily injury, electric shock, or property damage.

- Lead assemblies on submersible motors are suitable only for use in water and may overheat and cause failure if operated in air.

The motor leads are smaller than specified in this manual's cable tables because:

- The leads are considered a part of the motor and are a connection between the large supply wire and the motor winding. The motor leads are short and there is virtually no voltage drop across the lead.
- The lead assemblies operate under water, while at least part of the supply cable must operate in air. Lead assemblies running under water operate cooler.

Lead Connector Jam Nut Torque

Jam nut tightening torques recommended for field assembly are shown. Rubber compression set within the first few hours after assembly may reduce the jam nut torque. This is a normal condition which does not indicate reduced seal effectiveness. Retighten if original torque was questionable.

Do not reuse a motor lead assembly. Use a new lead assembly when one is removed from the motor because rubber set and possible damage may prevent proper resealing of the old lead.

NOTE: All motors returned for warranty consideration must have the lead returned with the motor.

NOTE: 8-inch MagForce, 10-inch and 12-inch motor leads are not Field Replaceable.

Table 14.

Motor Type	Torque
4" with Jam Nut	15 to 20 ft-lb (20 to 27 Nm)
4" with 2 Screw Clamp Plate	35 to 45 in-lb (4.0 to 5.1 Nm)
6"	40 to 50 ft-lb (54 to 68 Nm)
8" with 1-3/16" to 1-5/8" Jam Nut	50 to 60 ft-lb (68 to 81 Nm)
8" with 4 Screw Clamp Plate*	Apply increasing torque to the screws equally in a criss-cross pattern until 80 to 90 in-lb (9.0 to 10.2 Nm) is reached.

*Does not apply to 8-inch MagForce motors.

Pump to Motor Coupling Assembly

Assemble coupling with non-toxic FDA approved waterproof grease such as Mobile FM222, Texaco CYG-NUS2661, or approved equivalent. This prevents abrasives from entering the spline area and prolongs spline life.

Pump to Motor Assembly Torque

After assembling the motor to the pump, torque mounting fasteners in a criss-cross pattern to the following:

Table 15.

Pump and Motor Type (inches)	Torque
4	10 lb-ft (14 Nm)
6	50 lb-ft (68 Nm)
8	120 lb-ft (163 Nm)
10	170 lb-ft (230 Nm)
12	220 lb-ft (300 Nm)

Shaft Height and Free End Play

Table 16.

Motor Type	Normal Shaft Height		Dimension Shaft Height inches (mm)		Free End Play inches (mm)	
	inches	mm	Min	Max	Min	Max
4 inch	1 1/2	38.1	1.498 (38.05)	1.508 (38.30)	0.010 (0.25)	0.045 (1.14)
6 inch	2 7/8	73.0	2.860 (72.64)	2.875 (73.02)	0.030 (0.76)	0.050 (1.27)
8 inch Type 1	4	101.6	3.990 (101.35)	4.000 (101.60)	0.008 (0.20)	0.032 (0.81)
8 inch Type 2.1					0.030 (0.76)	0.080 (2.03)
10 inch	4	101.6	3.990 (101.35)	4.000 (101.60)	0.028 (0.70)	0.079 (2.00)
12 inch	5	127.0	4.990 (126.7)	5.000 (127.0)	0.024 (0.60)	0.098 (2.50)

NOTE: If the height, measured from the pump-mounting surface of the motor, is low and/or end play exceeds the limit, replace the motor thrust bearing that is possibly damaged.

MOTOR MAINTENANCE

System Troubleshooting

Table 17.

Condition	Possible Cause	Checking Procedures	Corrective Action
Motor does not start	No power or incorrect voltage	Check voltage at line terminals. The voltage must be $\pm 10\%$ of rated voltage.	Contact power company if voltage is incorrect.
	Fuses blown or circuit breakers tripped	Check fuses for recommended size and check for loose, dirty or corroded connections in fuse receptacle. Check for tripped circuit breakers.	Replace with proper fuse or reset circuit breakers.
	Defective pressure switch	Check voltage at contact points. Improper contact of switch points can cause voltage less than line voltage.	Replace pressure switch or clean points.
	Control box malfunction	For detailed procedure, see "Single-Phase Motors & Controls" on page 38.	Repair or replace.
	Defective wiring	Check for loose or corroded connections or defective wiring.	Correct faulty wiring or connections.
	Bound pump	Check for misalignment between pump and motor or a sand bound pump. Amp readings will be 3 to 6 times higher than normal until the overload trips.	Pull pump and correct problem. Run new installation until the water clears.
	Defective cable or motor	For detailed procedure, see "Preliminary Tests" on page 36.	Repair or replace.
Motor starts too often	Pressure switch	Check setting on pressure switch and examine for defects.	Reset limit or replace switch.
	Check valve - stuck open	Damaged or defective check valve will not hold pressure.	Replace if defective.
	Waterlogged tank	Check air charge.	Clean or replace.
	Leak in system	Check system for leaks.	Replace damaged pipes or repair leaks.
Motor Runs Continuously	Pressure switch	Check switch for welded contacts. Check switch adjustments.	Clean contacts, replace switch, or adjust setting.
	Low water level in well	Pump may exceed well capacity. Shut off pump, wait for well to recover. Check static and drawdown level from well head.	Throttle pump output or reset pump to lower level. Do not lower if sand may clog pump.
	Leak in system	Check system for leaks.	Replace damaged pipes or repair leaks.
	Worn pump	Symptoms of worn pump are similar to those of drop pipe leak or low water level in well. Reduce pressure switch setting, if pump shuts off worn parts may be the fault.	Pull pump and replace worn parts.
	Loose coupling or broken motor shaft	Check for loose coupling or damaged shaft.	Replace worn or damaged parts.
	Pump screen blocked	Check for clogged intake screen.	Clean screen and reset pump depth.
	Check valve stuck closed	Check operation of check valve.	Replace if defective.
Control box malfunction	See "Single-Phase Motors & Controls" on page 38 for single-phase.	Repair or replace.	
Motor runs but overload protector trips	Incorrect voltage	Using voltmeter, check the line terminals. Voltage must be within $\pm 10\%$ of rated voltage.	Contact power company if voltage is incorrect.
	Overheated protectors	Direct sunlight or other heat source can raise control box temperature causing protectors to trip. The box must not be hot to touch.	Shade box, provide ventilation or move box away from source.
	Defective control box	For detailed procedures, see "Single-Phase Motors & Controls" on page 38.	Repair or replace.
	Defective motor or cable	For detailed procedures, see "Preliminary Tests" on page 36.	Repair or replace.
	Worn pump or motor	Check running current, see motor specifications tables in "Motor, Cable, & Fuse/Circuit Breaker Reference" on page 49.	Replace pump and/or motor.

Preliminary Tests

Complete these tests before removing the motor from the well or other location. These tests are for all sizes, including single- and three-phase.

NOTE:

- Check Line-to-Line voltage (Nameplate +/-10%)
- Check amperage in all motor wires (See [“Motor, Cable, & Fuse/Circuit Breaker Reference”](#) on page 49)
- Check Line-to-Ground insulation resistance
- Check Line-to-Line winding resistance

Insulation Resistance

1. Open master breaker and disconnect all leads from control box or pressure switch to avoid electric shock hazard and damage to the meter.

NOTE: For QD-type controls, remove lid.

2. Use a megohmmeter set to 500 Volt (1000 Volt maximum).
 - If using an ohmmeter, set to R X 100k. Zero the meter.
3. Connect one meter lead to any one of the motor leads and the other lead to the ground wire, metal drop pipe, or metal well casing.
 - If the drop pipe is plastic, connect the meter lead to ground.
4. Check if the ohms value is normal ([“Insulation Resistance Readings”](#) on page 37).
 - If the ohms value is normal, the motor is not grounded and the cable insulation is not damaged.
 - If the ohms value is below normal, either the windings are grounded or the cable insulation is damaged. Check that the cable insulation at the well seal is not being pinched.

Figure 17.

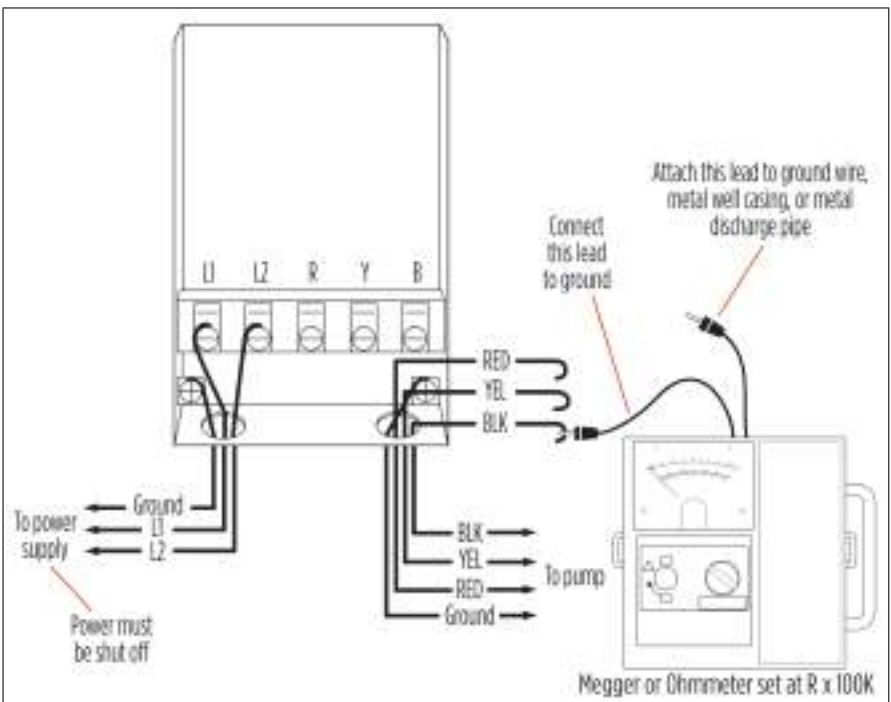

Insulation Resistance Readings

Insulation resistance varies little with rating. Motors of all hp, voltage, and phase rating have similar values of insulation resistance. This table is based on readings taken with a megohmmeter with a 500 VDC output. Readings may vary using a lower voltage ohmmeter; consult Franklin Electric if readings are in question.

Condition of motor & leads	In well?	Megohm Value	Ohms Value
A new motor (without drop cable)	No	200.0 (or more)	200,000,000 (or more)
A used motor which can be reinstalled in well	No	10.0 (or more)	10,000,000 (or more)
*New motor	Yes	2.0 (or more)	2,000,000 (or more)
*Motor in good condition	Yes	0.50 - 2.0	500,000 - 2,000,000
*Insulation damage(locate and repair)	Yes	Less than .50	Less than 500,000

NOTE: *Readings are for drop cable plus motor

Winding Resistance

1. Open master breaker and disconnect all leads from control box or pressure switch (QD type control, remove lid) to avoid electric shock hazard and damage to the meter.
2. Use a multi-meter set to 20 ohms or an ohmmeter set to R X 1 for values under 10 ohms.
 - Use next scale up for values over 10 ohms.
 - Zero the meter.
3. On 3-wire motors measure the resistance of yellow to black (main winding) and yellow to red (start winding).
4. On 2-wire motors measure the resistance from line-to-line.
5. For three-phase motors measure the resistance line-to-line for all three combinations.
6. Check ohms values.

Figure 18.

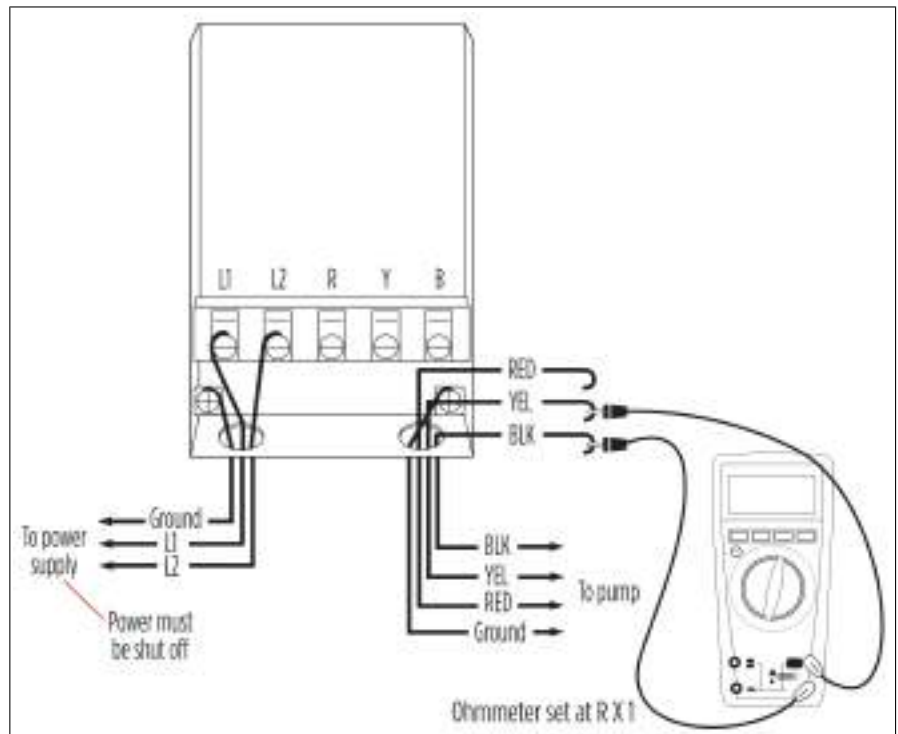

- If all ohms values are normal (see motor specifications tables in [“Motor, Cable, & Fuse/Circuit Breaker Reference” on page 49](#)), the motor windings are neither shorted nor open, and the cable colors are correct.
- If any one value is less than normal, the motor is shorted.
- If any one ohm value is greater than normal, the winding or the cable is open, or there is a poor cable joint or connection.
- If some ohms values are greater than normal and some less on single-phase motors, the leads are mixed. Refer to [“Cable Identification” on page 38](#) to verify cable colors.

MOTOR MAINTENANCE

Single-Phase Motors & Controls

Resistance of Drop Cable (ohms)

The values in [“Table 17” on page 38](#) are for two copper conductors per 100 feet of wire at 50 °F . If aluminum conductor drop cable is used, the resistance will be higher. To determine the actual resistance of the aluminum drop cable, divide the ohm readings from this table by 0.61. This table shows total resistance of cable from control to motor and back.

NOTE: The winding resistance measured at the motor should fall within the values specified in the motor spec tables in [“Motor, Cable, & Fuse/Circuit Breaker Reference” on page 49](#). When measured through the drop cable, subtract the resistance of the drop cable from the ohmmeter readings to get the winding resistance of the motor.

Table 18.

AWG or MCM Wire Size (Copper)	Resistance per 100 ft of distance (ohms)
14	0.544
12	0.338
10	0.214
8	0.135
6	0.082
4	0.052
3	0.041
2	0.032
1	0.026
1/0	0.021
2/0	0.017
3/0	0.013
4/0	0.010
250	0.0088
300	0.0073
350	0.0063
400	0.0056
500	0.0044
600	0.0037
700	0.0032

Single-Phase Motors & Controls

Cable Identification

NOTE: For single-phase, 3-wire units.

- If the colors on the individual drop cables cannot be found with an ohmmeter, measure:
 - Cable 1 to Cable 2; Cable 2 to Cable 3; Cable 3 to Cable 1
- Find the highest resistance reading.
 - The lead not used in the highest reading is the yellow lead.
- Use the yellow lead and each of the other two leads to get two readings:
 - Highest is the red lead. Lowest is the black lead.

Example Results:

- The lead not used in the highest reading (6 ohms) was Cable 3, making it the yellow lead.
- The yellow lead’s highest reading was 4 ohms. The other cable in this reading was Cable 1, making it the red lead.
- The yellow lead’s lowest reading was 2 ohms. The other cable in this reading was Cable 3, making it the black lead.

Table 19. Example

Cables	Ohmmeter Reading
Cable 1 to Cable 2	6 ohms
Cable 2 to Cable 3	2 ohms
Cable 3 to Cable 1	4 ohms

Control Box Checks

WARNING



Contact with hazardous voltage could result in death or serious injury.

- Power must be on for these tests. Do not touch any live parts.

IMPORTANT: Regard the component tests in this manual as indicative and not as conclusive. For example, a capacitor may test good (not open, not shorted) but may have lost some of its capacitance and no longer be able to perform its function.

Voltage Measurements

1. Ensure the motor is off.
2. Measure voltage at L1 and L2 of pressure switch or line contactor.
 - Ensure the voltage reading is $\pm 10\%$ of motor rating.
3. Turn the motor on until it is running normally.
4. Measure voltage at load side of pressure switch or line contactor with pump running.
 - Ensure the voltage reading remains the same except for slight dip on starting. Loose connections, bad contacts, ground faults, or inadequate power supply can cause excessive voltage drop.
 - Either low voltage or ground faults cause relay chatter.

Current (Amp) Measurements

Measure current on all motor leads.

- For the amp reading, refer to [“4-inch / Single-Phase / Encapsulated Motor Specs / 3450 RPM” on page 51](#) and [“6-inch / Single-Phase / 3-Lead / Encapsulated Motor Specs / 3450 RPM” on page 63](#).
 - Ensure current in red lead is momentarily high, then drop within one second to those values. This verifies relay or solid state relay operation.
 - Check current in black and yellow leads does not exceed those values.
- Relay or switch failures cause red lead current to remain high and overload tripping.
- Open run capacitor(s) cause amps to be higher than normal in the black and yellow motor leads and lower than normal in the red motor lead.
- A bound pump causes locked rotor amps and overloading tripping.
- Pump running at shut-off, worn pump, or stripped splines may cause low amps.
- Failed start capacitor or open switch/relay are indicated if the red lead current is not momentarily high at starting.

MOTOR MAINTENANCE
Single-Phase Motors & Controls

Ohmmeter Tests

IMPORTANT: The component tests in this manual are indicative, not conclusive. For example, a capacitor may test good (not open, not shorted) but may have lost some of its capacitance and no longer be able to perform its function.

IMPORTANT: Perform these tests with the power off

QD, Solid State Control Box

Table 20.

Test	Meter Setting	Connections	Correct Motor Reading
Start Capacitor and Run Capacitor (CRC), if applicable	R x 1,000	Capacitor terminals	Pointer should swing toward zero, then back to infinity.
Q.D. (Blue) Relay Triac Test	R x 1,000	Cap and B terminal	Infinity for all models
Q.D. (Blue) Relay Coil Test	R x 1	L1 and B	Zero ohms for all models.
Potential (Voltage) Relay: Coil Test	R x 1,000	#2 & #5	For 115 Volt Boxes: 0.7-1.8 (700 to 1,800 ohms). For 230 Volt Boxes: 4.5-7.0 (4,500 to 7,000 ohms).
Potential (Voltage) Relay: Contact Test	R x 1	#1 & #2	Zero for all models.

Integral Horsepower Control Box

Table 21.

Test	Meter Setting	Connections	Correct Motor Reading
Overloads (Push Reset Buttons to make sure contacts are closed.)	R x 1	Overload terminals	Less than 0.5 ohms
Capacitor (Disconnect leads from one side of each capacitor before checking.)	R x 1,000	Capacitor terminals	Pointer should swing toward zero, then drift back to infinity, except for capacitors with resistors which will drift back to 15,000 ohms.
Potential (Voltage) Relay: Coil Test	R x 1,000	#2 & #5	4.5-7.0 (4,500 to 7,000 ohms) for all models.
Potential (Voltage) Relay: Contact Test	R x 1	#1 & #2	Zero ohms for all models
Contactors: Coil Test	R x 100	Coil terminals	1.8-14.0 (180 to 1,400 ohms)
Contactors: Contacts (Manually close the contacts)	R X 1	L1 & T1 or L2 & T2	Zero ohms

Ordering Information

QD Control Box Parts

Table 22.

HP	Volts	Control Box Model Number	QD (Blue) Relay	Start Capacitor			Run Capacitor		
				Order Number	MFD	Volts	Order Number	MFD	Volts
1/3	115	280 102 4915	223 415 905	275 464 125	159-191	110	—	—	—
	230	280 103 4915	223 415 901	275 464 126	43-53	220	—	—	—
1/2	115	280 104 4915	223 415 906	275 464 201	250-300	125	—	—	—
		280 105 4915	223 415 902	275 464 105	59-71	220	—	—	—
	282 405 5015 (CRC)	223 415 912	275 464 126	43-53	156 362 101		15	370	
3/4	230	280 107 4915	223 415 903	275 464 118	86-103		—	—	—
		282 407 5015 (CRC)	223 415 913	275 464 105	59-71	156 362 102	23	370	
1	230	280 108 4915	223 415 904	275 464 113	105-126	—	—	—	
		282 408 5015 (CRC)	223 415 914	275 464 118	86-103	156 362 102	23	370	

NOTE: Control boxes supplied with QD Relays are designed to operate on 230 Volt systems. For 208 Volt systems or where line voltage is between 200 volts and 210 volts use the next larger cable size, or use a boost transformer to raise the voltage.

QD Capacitor Replacement Kits

Table 23.

Capacitor Number	Kit
275 464 105	305 207 905
275 464 113	305 207 913
275 464 118	305 207 918
275 464 125	305 207 925
275 464 126	305 207 926
275 464 201	305 207 951
156 362 101	305 203 907
156 362 102	305 203 908

NOTE: Voltage relays kits for 115 Volts (305 102 901) and 230 Volts (305 102 902) will replace current, voltage or QD Relays, and Solid State Switches.

MOTOR MAINTENANCE
Single-Phase Motors & Controls

Integral Horsepower Control Box Parts

Table 24.

Motor Size (inches)	Motor Rating (HP)	Control Box ¹ Model No.	Capacitors				Part Number			
			Part No. ²	MFD.	Volts	QTY	Overload ²	Relay ³	Contact ²	
4	1 - 1.5	282 300 8110 Standard	275 464 113 S	105-126	220	1	275 411 107	155 031 102	—	
			155 328 102 R	10	370		275 411 114 S			
		282 300 8110 Standard (See Note 4)	275 464 137 S	105-126	220		275 411 113 M			
			155 328 101 R	15	370		275 411 117 S			
	2	282 301 8110 Standard	275 464 137 S	105-126	220		275 411 113 M	155 031 102	—	
			155 328 103 R	20	370		275 411 117 S	155 031 102	155 325 102 L	
	2	282 301 8310 Deluxe	275 464 137 S	105-126	220		275 411 113 M			155 031 102
			155 328 103 R	20	370		275 411 118 S	155 031 102	—	
	3	282 302 8110 Standard	275 463 123 S	208-250	220		275 411 115 M			155 031 102
			155 327 109 R	45	370		275 411 118 S	155 031 102	155 325 102 L	
	3	282 302 8310 Deluxe	275 463 123 S	208-250	220		275 411 115 M			155 031 102
			155 327 109 R	45	370		275 411 119 S	155 031 601	—	
4 & 6	5	282 113 8110 Standard	275 468 118 S	216-259	330	2	275 406 102 M	155 031 601	—	
			155 327 114 R	40	370		275 411 119 S			
	5	282 113 9310 Deluxe	275 468 118 S	216-259	330	1	275 411 119 S	155 031 601	155 326 101 L	
			155 327 114 R	40	370	2	275 406 102 M	155 031 601	155 326 101 L	
6	7.5	282 201 9210 Standard	275 468 119 S	270-324	330	1	275 411 102 S	155 031 601	—	
			275 468 117 S	130-154			275 406 122 M			
			155 327 109 R	45			370			
	7.5	282 201 9310 Deluxe	275 468 119 S	270-324	330	1	275 411 102 S	155 031 601	155 326 102 L	
			275 468 117 S	130-154			275 406 121 M			
			155 327 109 R	45			370			
	10	282 202 9210 Standard	275 468 119 S	270-324	330	1	275 406 103 S	155 031 601	—	
			275 468 120 S	350-420			155 409 101 M			
		282 202 9230 Standard	275 468 119 S	270-324	330	2	275 406 103 S		155 409 101 M	—
			155 327 102 R	35			370		155 409 101 M	
	10	282 202 9310 Deluxe	275 468 119 S	270-324	330	1	275 406 103 S	155 031 601	155 326 102 L	
			275 468 120 S	350-420			155 409 101 M			
		282 202 9330 Deluxe	275 468 119 S	270-324	330	2	275 406 103 S		155 409 101 M	155 326 102 L
			155 327 102 R	35			370		155 409 101 M	
	15	282 203 9310 Deluxe	275 468 120 S	350-420	330	2	275 406 103 S	155 031 601	155 429 101 L	
			155 327 109 R	45			370			155 409 102 M
		282 203 9330 Deluxe	275 468 119 S	270-324	330	2	275 406 103 S			155 409 102 M
			155 327 109 R	45			370			155 409 102 M
	15	282 203 9621 X-Large	275 468 119 S	270-324	330	2	275 406 103 S	155 031 601 (2 required)	155 429 101 L	
			155 327 109 R	45			370			155 409 102 M

NOTE:

- (1) Surge arrestors 150 814 902 are suitable for all control boxes.
- (2) S = Start, M = Main, L = Line, R = Run, Deluxe = Control box with line contactor.
- (3) Control box model 282 300 8110 with date code 11C19 (March 2011) and newer. These models contain 15 MFD run capacitor and both start and run overloads. This box is designed for use with any Franklin 1.5 hp motor.
- (4) For 208 Volt systems or where line voltage is between 200 volts and 210 volts, a low voltage relay is required. On 3 hp and smaller control boxes use relay part 155 031 103 in place of 155 031 102 and use the next larger cable size than specified in the 230 Volt table. On 5 hp and larger use relay 155 031 602 in place of 155 031 601 and next larger wire. Boost transformers are an alternative to special relays and cable. Refer to [“Buck-Boost Transformers” on page 14.](#)

Integral HP Capacitor Replacement Kits

Table 25.

Capacitor Number	Kit
275 463 120	305 206 920
275 463 122	305 206 922
275 463 123	305 206 923
275 464 113	305 207 913
275 464 137	305 207 937
275 468 117	305 208 917
275 468 118	305 208 918
275 468 119	305 208 919
275 468 120	305 208 920
155 327 101	305 203 901
155 327 102	305 203 902
155 327 109	305 203 909
155 327 114	305 203 914
155 328 101	305 204 901
155 328 102	305 204 902
155 328 103	305 204 903

Integral HP Overload Replacement Kits

Table 26.

Overload Number	Kit
275 406 102	305 214 902
275 406 103	305 214 903
275 406 121	305 214 921
275 406 122	305 214 922
275 411 102	305 215 902
275 411 107	305 215 907
275 411 108	305 215 908
275 411 113	305 215 913
275 411 114	305 215 914
275 411 115	305 215 915
275 411 117	305 215 917
275 411 118	305 215 918
275 411 119	305 215 919

Integral HP Voltage Relay Replacement Kits

Table 27.

Relay Number	Description	Kit
155 031 102	230V Standard Duty	305 213 902
155 031 103	208V Standard Duty	305 213 903
155 031 601	230V Heavy Duty	305 213 961
155 031 602	208V Heavy Duty	305 213 962

MOTOR MAINTENANCE
Single-Phase Motors & Controls

Integral HP Contactor Replacement Kits

Table 28.

Contactor	Kit
155 325 102	305 226 902
155 326 101	305 347 903
155 326 102	305 347 902
155 429 101	305 347 901

Control Box Wiring Diagrams

Figure 19.

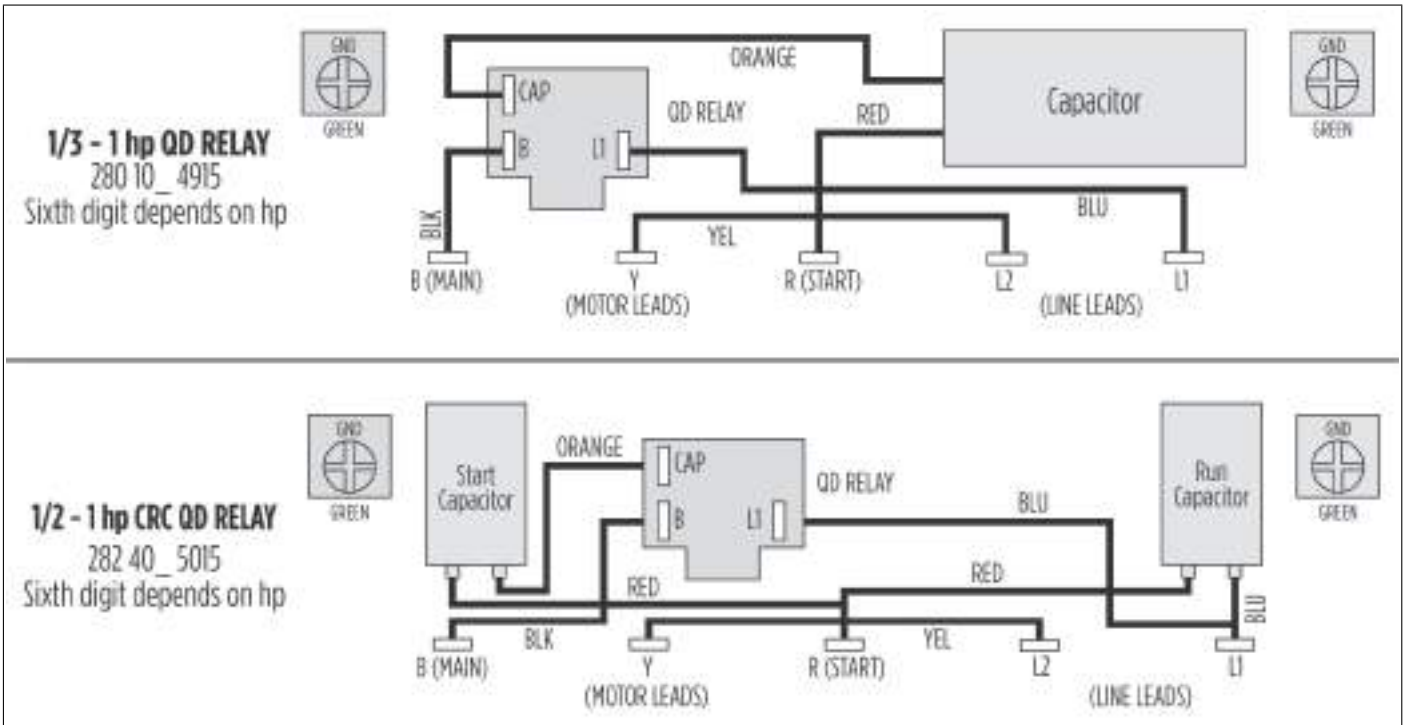

Figure 20.

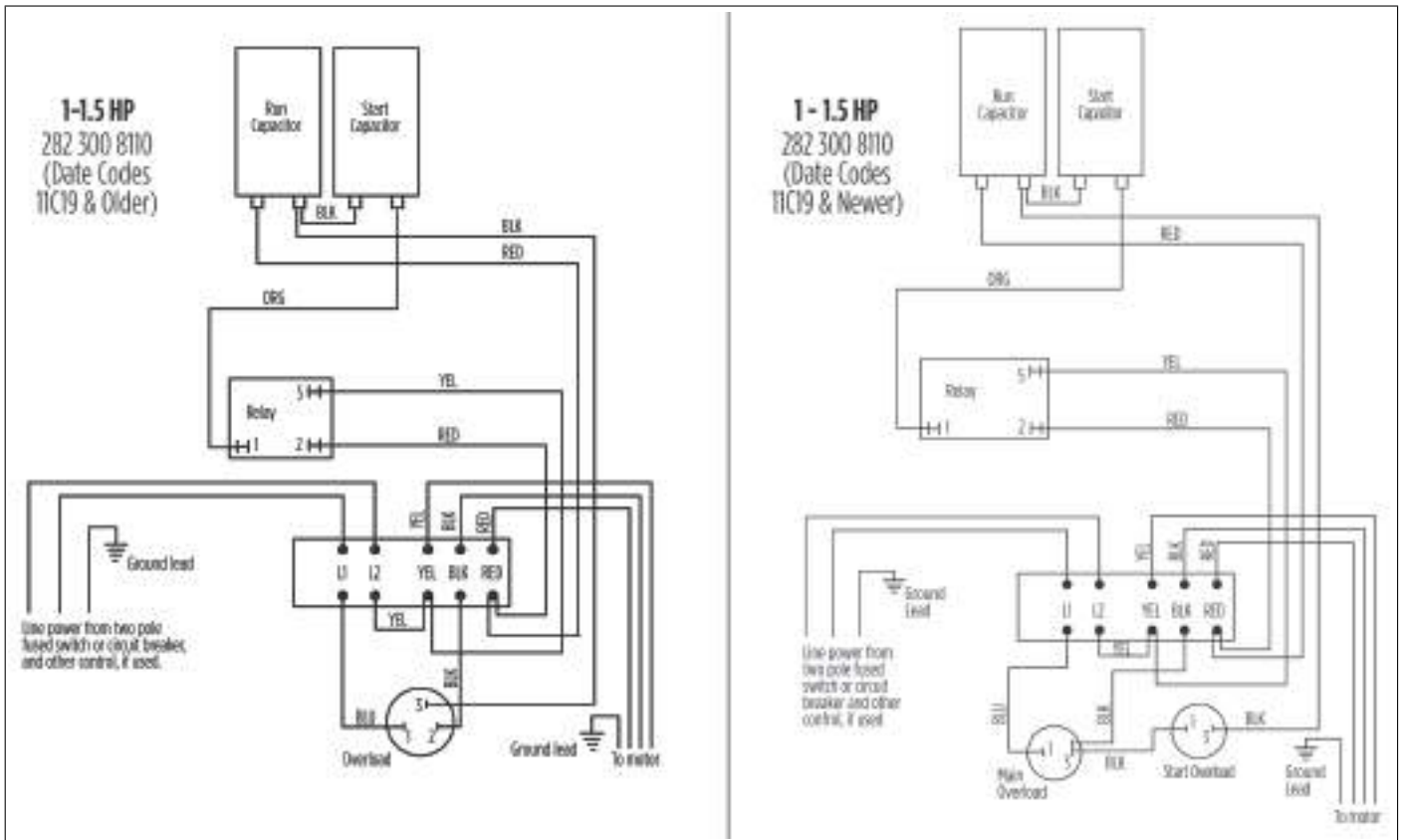
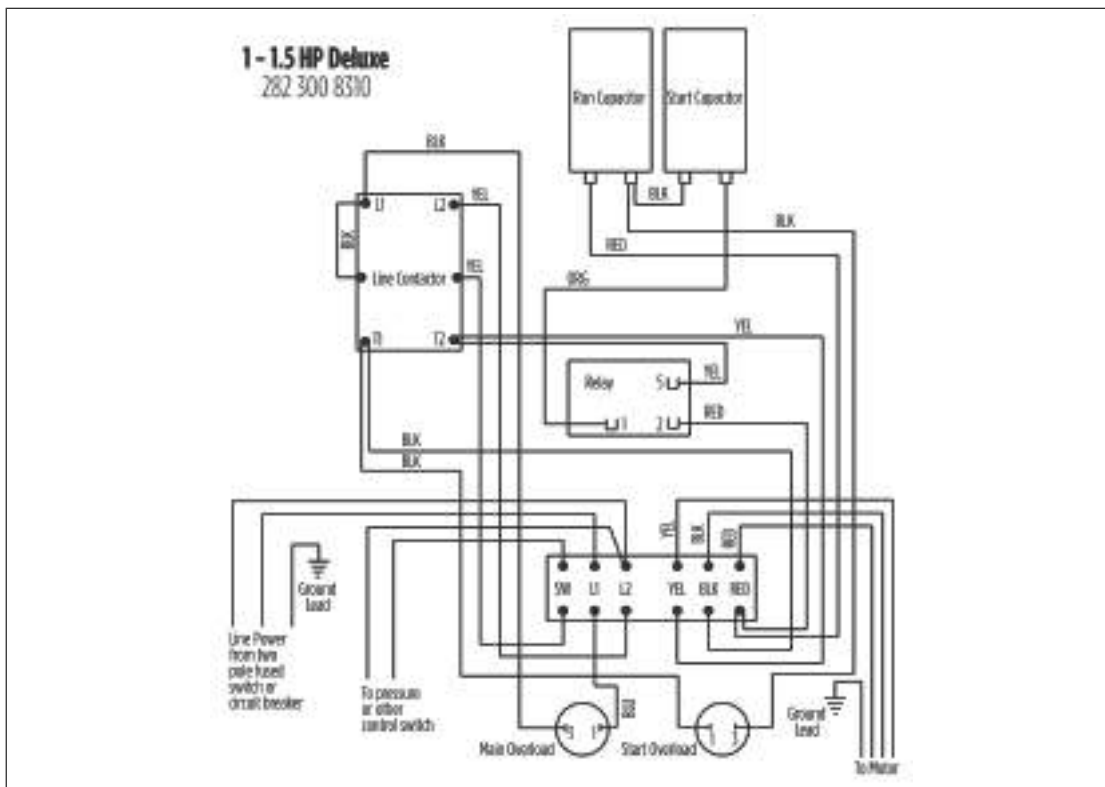

Figure 21.



MOTOR MAINTENANCE
Single-Phase Motors & Controls

Figure 22.

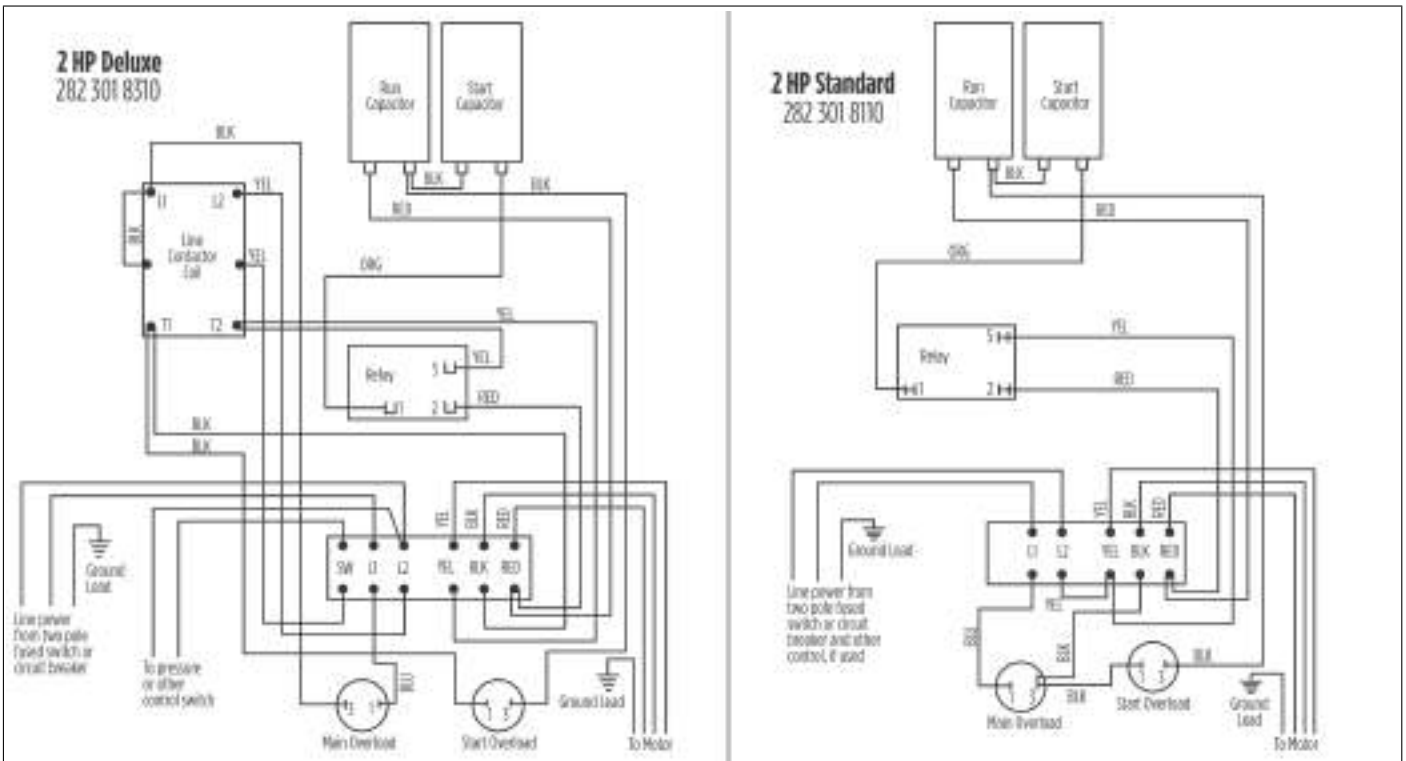

Figure 23.

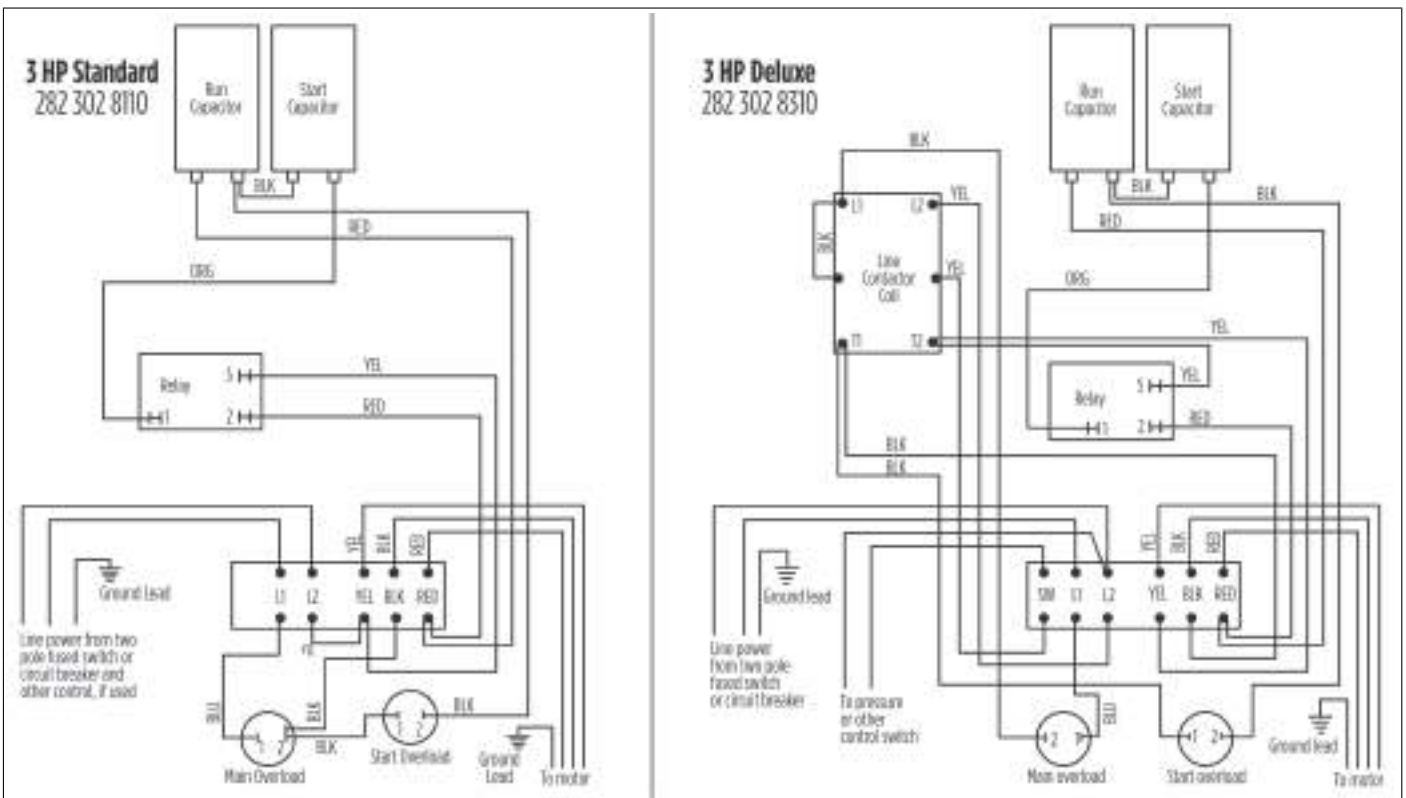

Figure 24.

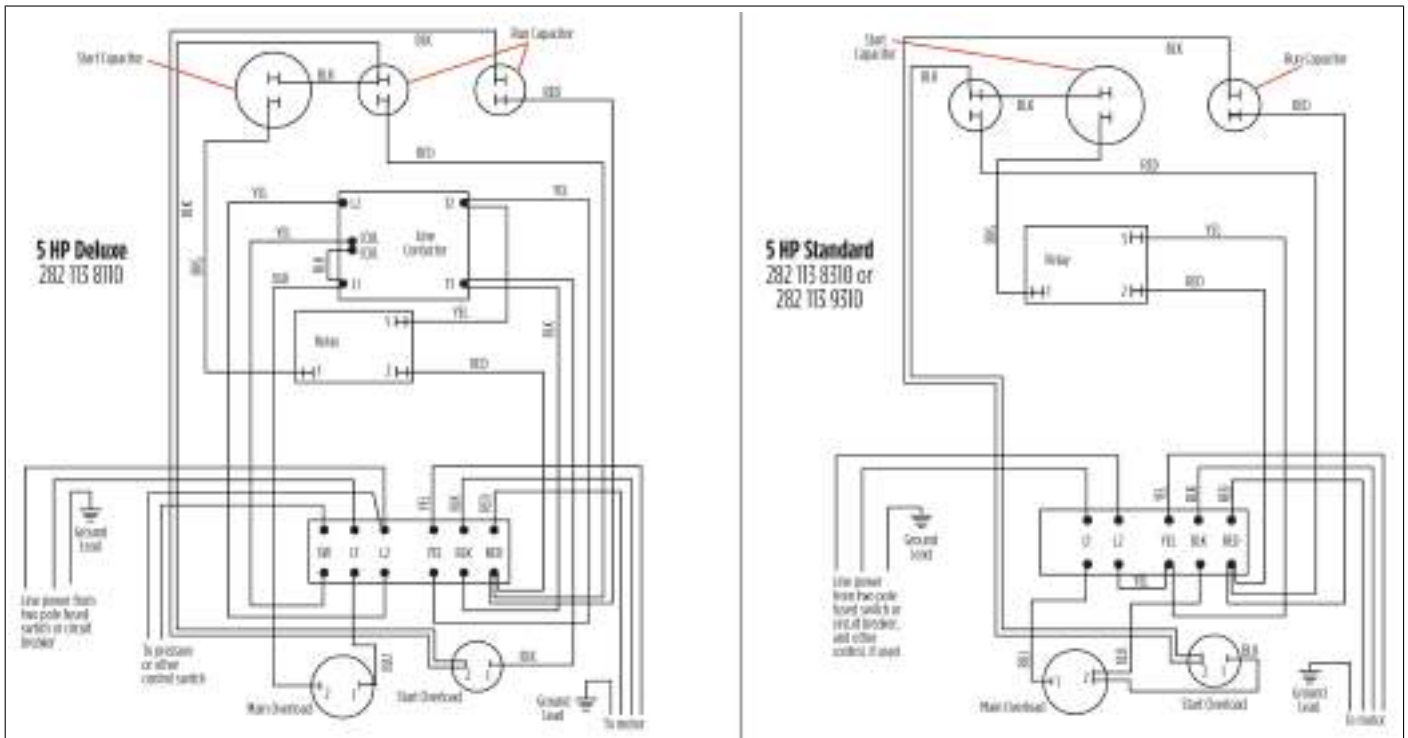
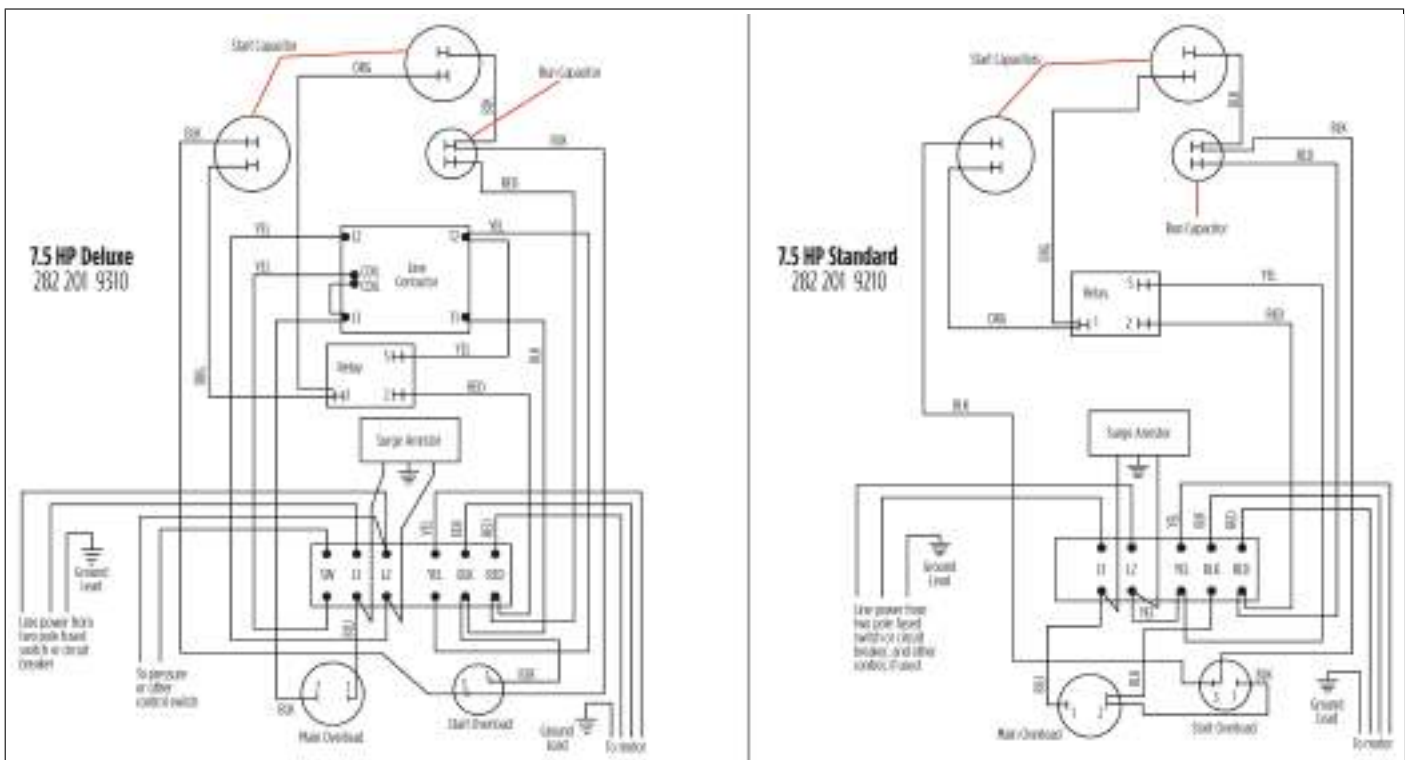

Figure 25.



MOTOR MAINTENANCE
Single-Phase Motors & Controls

Figure 26.

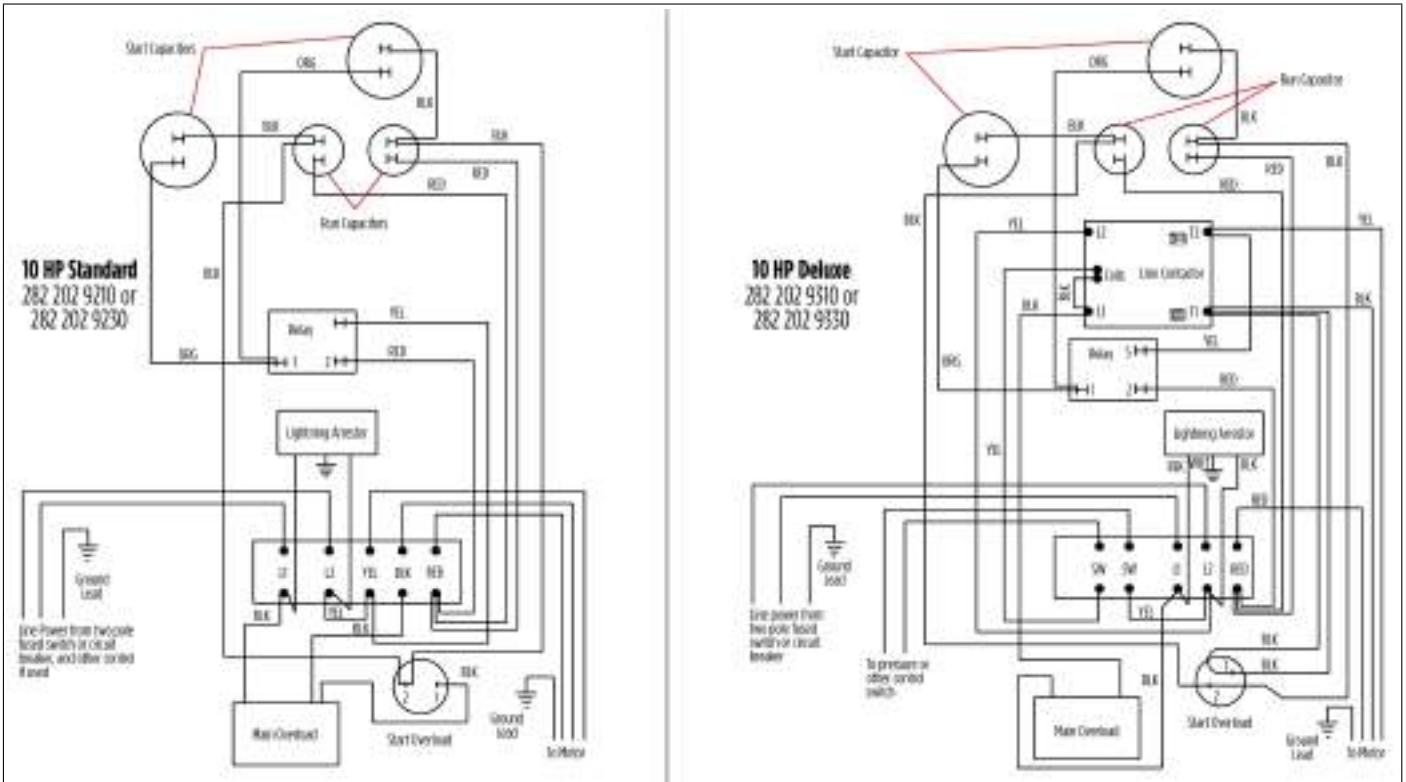
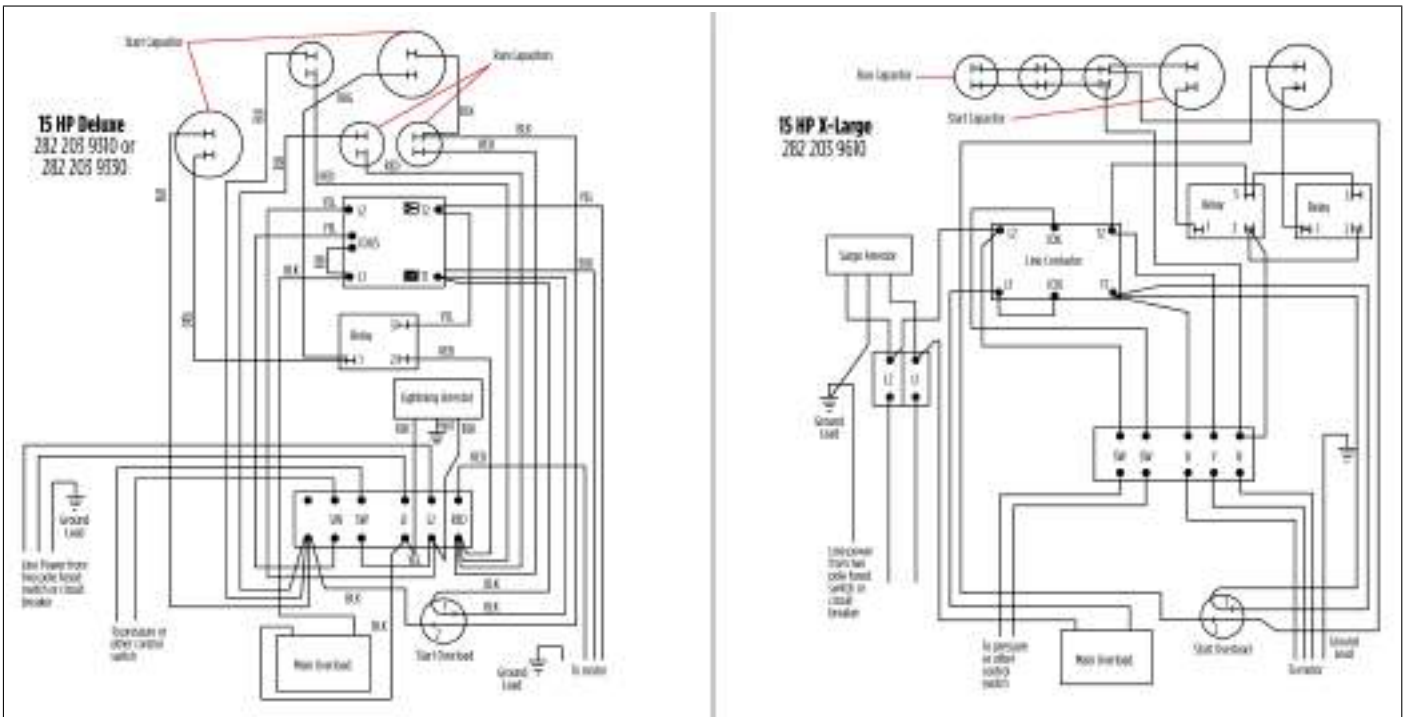

Figure 27.



MOTOR, CABLE, & FUSE/CIRCUIT BREAKER REFERENCE

Motor Specifications

The following tables provide detailed information on Franklin submersible motors. Individual motor performance curves can also be found online using FE Select.

Performance specifications given are typical and normal, but not guaranteed.

NOTE: For guaranteed performance, use a calibrated motor.

Cable Selection

Unshaded cells in the following cable reference tables meet the NEC ampacity requirements for either individual conductors or jacketed 75 °C cable and can be in conduit or direct buried. Flat molded and web/ribbon cable are considered jacketed cable. If any other cable is used, observe the NEC and local codes.

NOTE: Contact Franklin Electric or see the online AIM App for 60 °C and 90 °C cable charts.

Total cable length refers to the cable between the power supply and the motor. Cable lengths shown in the following cable tables allow for a 5% voltage drop when running at maximum nameplate amperes. Multiply the 5% voltage drop length by 0.6 to get the 3% voltage drop maximum cable length.

To ensure reliable contactor operation for single-phase systems using a Control Box with line contactor, the portion of the total cable length between the power supply and single-phase control box should not exceed 25% of the total allowable maximum. Single-phase Control Boxes without line contactors can be connected at any point in the total cable length.

Values found in the following tables are based on copper wire. If aluminum wire is used, it must be two sizes larger than copper wire, and oxidation inhibitors must be used on connections.

EXAMPLE: If #12 copper wire is called for, #10 aluminum wire would be required.

Cable Size Combinations

Depending on the installation, different combinations of cable can be used.

EXAMPLE: In a replacement/upgrade installation, the well already has 160 feet of buried #10 AWG copper wire installed cable between the service entrance and the wellhead.

A new 3 hp, 230 Volt, single-phase motor is being installed at 310 feet to replace a smaller motor.

NOTE: The below cable length specifications come from the cable selection tables included in this section.

- A 3 hp motor can use up to 300 feet of #10 AWG cable.
 - Using the formula, 160 feet (actual length) ÷ 300 feet (max allowed) = 0.533.
 - $0.533 \times 100 = 53.3\%$ of the allowable voltage drop or loss, between the service entrance and the motor, occurs in this wire.
 - 46.7% ($1.00 - 0.533 = 0.467$) of wire size is left to use in the remaining 310 feet "down hole" wire run.
- #8 AWG copper wire can use up to 470 feet.
 - Using the formula, 310 feet (actual length) ÷ 470 feet (max allowed) = 0.660
 - $0.533 + 0.660 = 1.193$
 - This is greater than 1.00 and will not meet NEC voltage drop requirements.
- #6 AWG copper wire can use up to 750 feet.
 - Using the formula, 310 feet (actual length) ÷ 750 feet (max allowed) = 0.413
 - $0.533 + 0.413 = 0.946$.
 - This is less than 1.00 and will meet NEC voltage drop requirements.

This works for two or more combinations of wire and it does not matter which size wire comes first in the installation.

Figure 28.

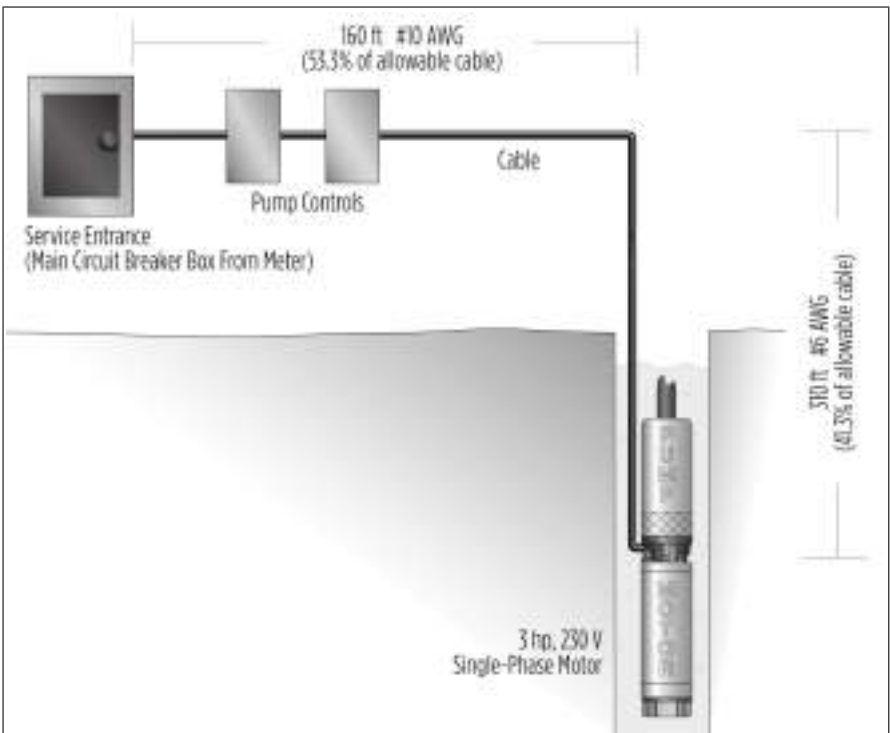

Figure 29. Cable Sizing Formula

$$\frac{\text{Actual Length}}{\text{Max Allowed}} + \frac{\text{Actual Length}}{\text{Max Allowed}} = 1.00$$

Motor Fuses/Circuit Breakers

Fuse and Circuit Breaker sizes are determined by local, state, and national electric codes.

Franklin's AIM tables list both the maximum allowable values per the National Electrical Code (NEC) and more conservative breaker/fuse sizes that are typically used in submersible applications. Either size will protect the circuit, but never exceed the maximum NEC value.

4-inch Motor, Cable, & Fuse/Circuit Breaker Reference

4-inch / Single-Phase / Encapsulated Motor Specs / 3450 RPM

Table 29.

Type	Motor Model Prefix	Rating				Full Load		Maximum Load		[1] Winding Res. in ohms	Efficiency %		Power Factor %		Locked Rotor Amps	KVA Code
		HP	KW	Volts	SF	[2] Amps	Watts	[2] Amps	Watts	M=Main Res. S=Start Res.	SF	FL	SF	FL		
4" 2-Wire	244504	1/2	0.37	115	1.6	10.0	670	12.0	960	1.0 – 1.3	62	56	73	58	64.4	R
	244505	1/2	0.37	230	1.6	5.0	670	6.0	960	4.2 – 5.2	62	56	73	58	32.2	R
	244507	3/4	0.55		1.5	6.8	940	8.0	1310	3.0 – 3.6	64	59	74	62	40.7	N
	244508	1	0.75		1.4	8.2	1210	10.4	1600	2.2 – 2.7	65	62	74	63	48.7	N
	244309	1.5	1.1		1.3	10.6	1710	13.1	2280	1.5 – 2.1	64	63	83	76	66.2	M
4" 3-Wire	214504	1/2	0.37	115	1.6	Y10.0 B10.0 R0	670	Y12.0 B12.0 R0	960	M1.0-1.3 S4.1-5.1	62	56	73	58	50.5	M
	214505	1/2	0.37	230	1.6	Y5.0 B5.0 R0	670	Y6.0 B6.0 R0	960	M4.2-5.2 S16.7-20.5	62	56	73	58	23	M
	214507	3/4	0.55		1.5	Y6.8 B6.8 R0	940	Y8.0 B8.0 R0	1310	M3.0-3.6 S10.7-13.1	64	59	74	62	34.2	M
	214508	1	0.75		1.4	Y8.2 B8.2 R0	1210	10.4 10.4 R0	1600	M2.2-2.7 S9.9-12.1	65	62	74	63	41.8	L
4" 3-Wire w/CRC CB	214505	1/2	0.37		230	1.6	Y3.2 B3.7 R2.0	655	Y4.3 B4.0 R2.0	890	M4.2-5.2 S16.7-20.5	67	57	90	81	23
	214507	3/4	0.55	1.5		Y4.4 B5.0 R3.2	925	Y5.7 B5.2 R3.1	1220	M3.0-3.6 S10.7-13.1	69	60	92	84	34.2	M
	214508	1	0.75	1.4		Y5.6 B5.7 R3.4	1160	Y8.1 B6.2 R3.3	1490	M2.2-2.7 S9.9-12.1	70	64	92	86	41.8	L
4" 3-Wire	214508 w/1-1.5 CB	1	0.75	230	1.4	Y6.6 B6.6 R1.3	1130	Y8.0 B7.9 R1.3	1500	M2.2-2.7 S9.9-12.1	70	66	82	72	43	L
	224300	1.5	1.1		1.3	Y10.0 B9.9 R1.3	1620	Y11.5 B11.0 R1.3	2080	M1.7-2.1 S7.5-9.2	70	69	85	79	51.4	J
	224301	2	1.5		1.25	Y10.0 B9.3 R2.6	2025	Y13.2 B11.9 R2.6	2555	M1.8-2.3 S5.5-7.2	73	74	95	94	53.1	G
	224302	3	2.2		1.15	Y14.0 B11.2 R6.1	3000	Y17.0 B12.6 R6.0	3400	M1.1-1.4 S4.0-4.8	75	75	99	99	83.4	H
	224303	5	3.7		1.15	Y23.0 B15.9 R11.0	4830	Y27.5 B19.1 R10.8	5500	M.71-.82 S1.8-2.2	78	77	100	100	129	G

1. M: Main winding = yellow to black; S: Start winding = yellow to red
2. Y: Yellow lead = line amps; B: Black lead = main winding amps; R: Red lead = start or auxiliary winding amps

NOTE: Performance is typical, not guaranteed, at specified voltages and capacitor values. Performance at voltage ratings not shown is similar, except amps vary inversely with voltage.

MOTOR, CABLE, & FUSE/CIRCUIT BREAKER REFERENCE
4-inch Motor, Cable, & Fuse/Circuit Breaker Reference

4-inch/Single-Phase/Encapsulated Motor Specs with "G" suffix/3450 RPM

e.g. 2445059004G

NOTE: For all model numbers with "7" as its fourth digit, even if ending with "G," consult ["4-inch / Single-Phase / Encapsulated Motor Specs 700 series / 3450 RPM"](#) on page 53.

Table 30.

Type	Motor Model Prefix	Rating				Full Load		Maximum Load		[1] Winding Res. in ohms	Efficiency %		Power Factor %		Locked Rotor Amps	KVA Code
		HP	KW	Volts	SF	[2] Amps	Watts	[2] Amps	Watts	M=Main Res. S=Start Res.	SF	FL	SF	FL		
4" 2-Wire	244504	1/2	0.37	115	1.6	10.0	660	12.0	1000	1.1-1.5	60	56	78	64	58.8	P
	244505	1/2	0.37	230	1.6	5.0	660	6.0	1000	4.7-5.8	60	56	78	64	28.5	P
	244507	3/4	0.55	230	1.5	6.8	925	8.0	1350	3.3-4.1	62	60	79	68	36.9	N
	244508	1	0.75	230	1.4	8.2	1215	10.4	1630	2.4-3.0	64	62	77	67	47.6	M
	244309	1.5	1.1	230	1.3	10.3	1690	13.1	2170	1.8-2.2	67	66	81	75	62.0	L
4" 3-Wire	214504	1/2	0.37	115	1.6	Y10.0 B10.0 R0	660	Y12.0 B12.0 R0	1000	M1.1-1.5 S4.3-5.3	60	56	78	64	44.1	M
	214505	1/2	0.37	230	1.6	Y5.0 B5.0 R0	660	Y6.0 B6.0 R0	1000	M4.7-5.8 S17.5-21.5	60	56	78	64	20.6	M
	214507	3/4	0.55	230	1.5	Y6.8 B6.8 R0	925	Y8.0 B8.0 R0	1350	M3.3-4.1 S11.2-13.8	62	60	79	68	29.7	L
	214508	1	0.75	230	1.4	Y8.2 B8.2 R0	1215	Y10.4 B10.4 R0	1630	M2.4-3.0 S10.2-12.6	64	62	77	67	35.9	K
4" 3-Wire w/CRC CB	214505	1/2	0.37	230	1.6	Y3.2 B3.7 R2.0	620	Y4.3 B4.0 R2.0	860	M4.7-5.8 S17.5-21.5	69	60	97	93	20.6	M
	214507	3/4	0.55	230	1.5	Y4.4 B5.0 R3.2	885	Y5.7 B5.2 R3.1	1185	M3.3-4.1 S11.2-13.8	71	63	99	98	29.7	L
	214508	1	0.75	230	1.4	Y5.6 B5.7 R3.4	1135	Y8.1 B6.2 R3.3	1455	M2.4-3.0 S10.2-12.6	72	66	96	93	35.9	K
4" 3-Wire	214508 w/1-1.5 CB	1	0.75	230	1.4	Y6.6 B6.6 R2.0	1150	Y8.0 B7.4 R1.9	1460	M2.4-3.0 S10.2-12.6	71	65	89	85	41.7	L
	224300	1.5	1.1	230	1.3	Y10.0 B9.3 R1.9	1540	Y11.5 B10.8 R1.9	1980	M1.9-2.4 S6.8-8.3	73	73	90	87	49.0	J
	224301	2	1.5	230	1.25	Y10.0 B8.8 R2.6	1985	Y13.2 B12.0 R2.5	2535	M1.8-2.3 S5.6-6.9	74	75	96	95	51.0	G
	224302	3	2.2	230	1.15	Y12.8 B8.7 R6.1	2930	Y17.0 B13.2 R5.8	3350	M1.2-1.5 S3.2-3.9	77	76	98	98	84.0	H
	224303	5	3.7	230	1.15	Y20.5 B13.5 R10.5	4740	Y27.5 B21.0 R10.0	5440	M.81-1.00 S1.8-2.3	79	78	100	100	126	G

1. M: Main winding = yellow to black; S: Start winding = yellow to red
2. Y: Yellow lead = line amps; B: Black lead = main winding amps; R: Red lead = start or auxiliary winding amps

NOTE: Performance is typical, not guaranteed, at specified voltages and specified capacitor values. Performance at voltage ratings not shown is similar, except amps vary inversely with voltage.

4-inch / Single-Phase / Encapsulated Motor Specs 700 series / 3450 RPM

e.g. 2247022504G, any model number with “7” as its fourth digit.

Table 31.

Type	Motor Model Prefix	Rating				Full Load		Maximum Load		[1] Winding Res. in ohms	Efficiency %		Power Factor %		Locked Rotor Amps	KVA Code
		HP	KW	Volts	SF	[2] Amps	Watts	[2] Amps	Watts	M=Main Res. S=Start Res.	SF	FL	SF	FL		
4" 3-Wire	224702	3	2.2	230	1.15	Y13.3 B10.6 R6.1	2980	Y17.0 B13.9 R5.9	3400	M1.1-1.4 S3.0-3.7	76	75	97	97	77.9	G
	224703	5	3.7			Y21.3 B14.5 R10.5	4860	Y27.5 B21.3 R10.1	5580	M0.78-0.95 S1.8-2.2	77	77	100	100	107	E

1. M: Main winding = yellow to black; S: Start winding = yellow to red
2. Y: Yellow lead = line amps; B: Black lead = main winding amps; R: Red lead = start or auxiliary winding amps

NOTE: Performance is typical, not guaranteed, at specified voltages and specified capacitor values. Performance at voltage ratings not shown is similar, except amps vary inversely with voltage.

4-inch / Single-Phase / 3-Lead / 75 °C Cable

Table 32.

Motor Rating			AWG Copper Wire Size												
Volts	HP	KW	14	12	10	8	6	4	3	2	1	0	00	000	0000
115	1/2	0.37	100	160	250	390	620	960	1190	1460	1780	2160	2630	3140	3770
230	1/2	0.37	400	650	1020	1610	2510	3880	4810	5880	7170	8720	-	-	-
	3/4	0.55	300	480	760	1200	1870	2890	3580	4370	5330	6470	7870	9380	-
	1	0.75	250	400	630	990	1540	2380	2960	3610	4410	5360	6520	7780	9350
	1.5	1.1	190	310	480	770	1200	1870	2320	2850	3500	4280	5240	6300	7620
	2	1.5	150	250	390	620	970	1530	1910	2360	2930	3620	4480	5470	6700
	3	2.2	120	190	300	470	750	1190	1490	1850	2320	2890	3610	4470	5550
	5	3.7	0	110	180	280	450	710	890	1110	1390	1740	2170	2680	3330

NOTE: If aluminum wire is used, it must be two sizes larger than copper wire and oxidation inhibitors must be used on connections.

NOTE: Shaded cells meet the NEC ampacity requirements for only individual conductors in free air or water. Unshaded cells meet NEC ampacity requirements for either individual conductors or jacketed cable. See [“Cable Selection” on page 49.](#)

MOTOR, CABLE, & FUSE/CIRCUIT BREAKER REFERENCE
4-inch Motor, Cable, & Fuse/Circuit Breaker Reference

4-inch / Single-Phase / Encapsulated Motor Fuse Sizing / 3450 RPM

NOTE: Fuse and beaker sizing is the same for Franklin standard, "G," and Series "700" 4-inch motors.

Table 33.

Type	Motor Model Prefix	Rating			Circuit Breaker or Fuse Amps					
		HP	KW	Volts	Maximum per NEC			Typical Submersible		
					Standard Fuse	Dual Element Time Delay Fuse	Circuit Breaker	Standard Fuse	Dual Element Time Delay Fuse	Circuit Breaker
4" 2-Wire	244504	1/2	0.37	115	35	20	30	30	15	30
	244505	1/2	0.37	230	20	10	15	15	8	15
	244507	3/4	0.55		25	15	20	20	10	20
	244508	1	0.75		30	20	25	25	11	25
	244309	1.5	1.1		35	20	30	35	15	30
214504	1/2	0.37	115		35	20	30	30	15	30
4" 3-Wire	214505	1/2	0.37	230	20	10	15	15	8	15
	214507	3/4	0.55		25	15	20	20	10	20
	214508	1	0.75		30	20	25	25	11	25
	214505	1/2	0.37		20	10	15	15	8	15
4" 3-Wire w/ CRC CB	214507	3/4	0.55	230	25	15	20	20	10	20
	214508	1	0.75		30	20	25	25	11	25
	214508 w/ 1-1.5 CB	1	0.75		30	20	25	25	11	25
4" 3-Wire	224300	1.5	1.1	230	35	20	30	30	15	30
	224301	2	1.5		30	20	25	30	15	30
	224302	3	2.2		45	30	40	45	20	40
	224303	5	3.7		80	45	60	70	30	60

For further table details, see ["Motor Specifications" on page 49.](#)

4-inch / Three-Phase / 3-Lead / Encapsulated Motor Specs / 3450 RPM

Table 34.

Motor Model Prefix	Rating				Full Load		Maximum Load		Winding Resistance (Ohms)	Efficiency %		Locked Rotor Amps	kVA Code			
	HP	KW	Volts	SF	Amps	Watts	Amps	Watts		SF	FL					
234904	1/2	0.37	48	1.6	10.3	590	13.3	870	.34-.43	68	63	67.3	N			
234501			200		2.8		3.4		6.6-8.4					70	64	17.5
234511			230		2.4		2.9		9.5-10.9							
234541			380		1.4		2.1		23.2-28.6							
234521			460		1.2		1.5		38.4-44.1							
234531			575		1.0		1.2		58.0-71.0							
234902	3/4	0.55	100	1.5	6.9	775	8.6	1105	.77-.94	76	72	58.0	M			
234502			200		3.6		4.4		4.6-5.9					73	69	24.6
234512			230		3.1		3.8		6.8-7.8							
234542			380		1.9		2.5		16.6-20.3							
234522			460		1.6		1.9		27.2-30.9							
234532			575		1.3		1.6		41.5-50.7							
234503	1	0.75	200	1.4	4.5	1070	5.4	1440	3.8-4.5	72	70	30.9	M			
234513			230		3.9		4.7		4.9-5.6							
234543			380		2.3		2.8		12.2-14.9							
234523			460		2.0		2.4		19.9-23.0							
234533			575		1.6		1.9		30.1-36.7					10.8		
234504	1.5	1.1	200	1.3	5.8	1460	6.8	1890	2.5-3.0	76	76	38.2	K			
234514			230		5.0		5.9		3.2-4.0							
234544			380		3.0		3.6		8.5-10.4							
234524			460		2.5		3.1		13.0-16.0							
234534			575		2.0		2.4		20.3-25.0					13.3		
234305	2.0	1.5	200	1.25	7.7	1960	9.3	2430	1.8-2.4	76	76	50.3	K			
234315			230		6.7		8.1		2.3-3.0							
234345			380		4.1		4.9		6.6-8.2							
234325			460		3.4		4.1		9.2-12.0							
234335			575		2.7		3.2		14.6-18.7					17.8		
234306	3.0	2.2	200	1.15	10.9	2920	12.5	3360	1.3-1.7	77	77	69.5	K			
234316			230		9.5		10.9		1.8-2.2							
234346			380		5.8		6.6		4.7-6.0							
234326			460		4.8		5.5		7.2-8.8							
234336			575		3.8		4.4		11.4-13.9					25.1		
234307	5	3.7	200	1.15	18.3	4800	20.5	5500	0.68-0.83	78	78	116	K			
234317			230		15.9		17.8		0.91-1.1							
234347			380		9.6		10.8		2.6-3.2							
234327			460		8.0		8.9		3.6-4.4							
234337			575		6.4		7.1		5.6-6.9					41.8		
234308	7.5	5.5	200	1.15	26.5	7150	30.5	8200	.45-.53	78	78	117	K			
234318			230		23.0		26.4		.60-.73							
234348			380		13.9		16.0		1.6-2.0							
234328			460		11.5		13.2		2.3-2.8							
234338			575		9.2		10.6		3.6-4.5					64.6		
234549	10	7.5	380	1.15	19.3	10000	21.0	11400	1.2-1.6	75	75	140	L			
234595			460		15.9		17.3		1.8-2.3							
234598			575		12.5		13.6		2.8-3.5					92.8		

MOTOR, CABLE, & FUSE/CIRCUIT BREAKER REFERENCE
4-inch Motor, Cable, & Fuse/Circuit Breaker Reference

Table 34 (continued)

Motor Model Prefix	Rating				Full Load		Maximum Load		Winding Resistance (Ohms)	Efficiency %		Locked Rotor Amps	kVA Code
	HP	KW	Volts	SF	Amps	Watts	Amps	Watts		SF	FL		
234646	15	11	380	1.15	27.6	14600	31.2	16800	.86-1.1	77	76	178	J
234626			460		22.8		25.8		1.2-1.5			147	
234636			575		18.2		20.7		1.9-2.4			118	

NOTE: Performance is typical, not guaranteed, at specified voltages. Performance at voltage ratings not shown is similar, except amps vary inversely with voltage.

4-inch/Three-Phase/3-Lead/Encapsulated Motor Specs with "G" suffix/3450 RPM

e.g. 2343278602G

NOTE: For all model numbers with "7" as its fourth digit, even if ending with "G," consult ["4-inch/Three-Phase/3-Lead/Encapsulated Motor Specs 700 series/3450 RPM" on page 57.](#)

Table 35.

Motor Model Prefix	Rating				Full Load		Maximum Load		Winding Resistance (Ohms)	Efficiency %		Locked Rotor Amps	kVA Code
	HP	KW	Volts	SF	Amps	Watts	Amps	Watts		SF	FL		
234501	1/2	0.37	200	1.6	2.8	580	3.4	865	7.7-9.4	69	64	16.0	N
234511			230		2.4		2.9		9.8-12.0			13.9	
234541			380		1.4		2.1		26.1-31.9			8.4	
234521			460		1.2		1.5		39.5-48.2			7.0	
234531			575		1.0		1.2		56.0-68.4			5.6	
234502	3/4	0.55	200	1.5	3.6	820	4.4	1180	5.4-6.7	71	68	22.4	M
234512			230		3.1		3.8		7.0-8.6			19.5	
234542			380		1.9		2.5		18.5-22.6			11.8	
234522			460		1.6		1.9		28.4-34.7			9.7	
234532			575		1.3		1.6		44.0-53.8			7.8	
234503	1	0.75	200	1.4	4.5	1060	5.4	1440	3.9-4.8	72	70	28.8	M
234513			230		3.9		4.7		5.1-6.3			25.0	
234543			380		2.3		2.8		13.5-16.5			15.1	
234523			460		2.0		2.4		20.7-25.3			12.5	
234533			575		1.6		1.9		32.6-39.9			10.0	
234504	1.5	1.1	200	1.3	5.8	1475	6.8	1915	2.8-3.4	76	76	34.8	K
234514			230		5.0		5.9		3.6-4.4			30.5	
234544			380		3.0		3.6		9.5-11.7			18.3	
234524			460		2.5		3.1		14.4-17.6			15.1	
234534			575		2.0		2.4		22.7-27.8			12.2	
234305	2.0	1.5	200	1.25	7.7	1935	9.3	2410	2.0-2.5	77	77	46.3	K
234315			230		6.7		8.1		2.6-3.2			40.1	
234345			380		4.1		4.9		7.6-9.3			25.3	
234325			460		3.4		4.1		10.4-12.7			20.9	
234335			575		2.7		3.2		16.4-20.0			16.4	
234306	3.0	2.2	200	1.15	10.9	2870	12.5	3310	1.4-1.7	78	78	65.2	J
234316			230		9.5		10.9		1.8-2.2			57.0	
234346			380		5.8		6.6		5.3-6.5			33.0	
234326			460		4.8		5.5		7.3-8.9			27.3	
234336			575		3.8		4.4		11.5-14.1			21.9	

MOTOR, CABLE, & FUSE/CIRCUIT BREAKER REFERENCE
4-inch Motor, Cable, & Fuse/Circuit Breaker Reference

Table 35 (continued)

Motor Model Prefix	Rating				Full Load		Maximum Load		Winding Resistance (Ohms)	Efficiency %		Locked Rotor Amps	kVA Code
	HP	KW	Volts	SF	Amps	Watts	Amps	Watts		SF	FL		
234307	5.0	3.7	200	1.15	16.1	4710	18.8	5410	0.81-1.0	79	79	123	K
234317			230		14.2		16.4		1.0-1.3			111	
234347			380		8.6		9.9		2.9-3.6			67.1	
234327			460		7.1		8.2		4.2-5.1			55.4	
234337			575		5.7		6.6		6.2-7.6			45.9	
234308	7.5	5.5	200	1.15	24	7000	28.2	8020	0.50-0.61	80	80	193	K
234318			230		21		24.6		0.67-0.82			171	
234348			380		12.7		14.9		1.9-2.3			104	
234328			460		10.5		12.3		2.7-3.3			87.9	
234338			575		8.2		9.8		4.1-5.0			71.0	L
234549	10	7.5	380	1.15	16.1	9200	18.6	10620	1.5-1.9	81	81	127	K
234595			460		13.3		15.4		2.2-2.7			105	
234598			575		10.7		12.4		3.5-4.3			81.6	

NOTE: Performance is typical, not guaranteed, at specified voltages. Performance at voltage ratings not shown is similar, except amps vary inversely with voltage.

4-inch/Three-Phase/3-Lead/Encapsulated Motor Specs 700 series/3450 RPM

e.g. 2347078600G, any model number with “7” as its fourth digit

Table 36.

Motor Model Prefix	Rating				Full Load		Maximum Load		Winding Resistance (Ohms)	Efficiency %		Locked Rotor Amps	kVA Code
	HP	KW	Volts	SF	Amps	Watts	Amps	Watts		SF	FL		
234707	5	3.7	200	1.15	17.4	4870	19.8	5580	0.78-0.95	77	76	111	J
234717			230		15.4		17.4		1.0-1.3			98.5	K
234747			380		9.1		10.4		2.8-3.5			58.5	J
234727			460		7.5		8.6		4.1-5.0			48.3	J
234737			575		6.1		6.9		6.0-7.3			42.0	K
234708	7.5	5.5	200	1.15	26.8	7190	30.0	8220	0.45-0.56	78	78	193	K
234718			230		21.8	7130	24.8	8190	0.65-0.80			171	
234748			380		13.2	7100	15.0	8140	1.8-2.2			104	
234728			460		10.9	12.4	2.6-3.2	87.9					
234738			575		8.9	7035	10.1	8065	3.8-4.7			71.0	
234749	10	7.5	380	1.15	17.1	9455	19.7	10925	1.5-1.8	78	79	127	K
234729			460		14.5	9375	16.5	10780	1.9-2.4			105	
234739			575		11.5	9550	13.2	11000	3.4-4.1			81.6	

NOTE: Performance is typical, not guaranteed, at specified voltages. Performance at voltage ratings not shown is similar, except amps vary inversely with voltage.

MOTOR, CABLE, & FUSE/CIRCUIT BREAKER REFERENCE
4-inch Motor, Cable, & Fuse/Circuit Breaker Reference

4-inch / Three-Phase / 3-Lead / 75 °C Cable

Table 37.

Motor Rating			Maximum Cable Length (ft) Measured from service entrance to motor																	
			AWG Copper Wire Size													MCM Copper Wire Size				
Volts	HP	KW	14	12	10	8	6	4	3	2	1	0	00	000	0000	250	300	350	400	500
48	1/2	0.37	40	70	110	170	270	420	520	650	790	960	1170	1400	1400	1680	—	—	—	—
100	3/4	0.55	150	140	380	580	900	1400	1710	2110	2570	3120	3790	3790	4510	5360	—	—	—	—
200	1/2	0.37	710	1140	1800	2840	4420	—	—	—	—	—	—	—	—	—	—	—	—	—
	3/4	0.55	510	810	1280	2030	3160	—	—	—	—	—	—	—	—	—	—	—	—	—
	1	0.75	430	690	1080	1710	2670	4140	5140	—	—	—	—	—	—	—	—	—	—	—
	1.5	1.1	310	500	790	1260	1960	3050	3780	—	—	—	—	—	—	—	—	—	—	—
	2	1.5	240	390	610	970	1520	2360	2940	3610	4430	5420	—	—	—	—	—	—	—	—
	3	2.2	180	290	470	740	1160	1810	2250	2760	3390	4130	—	—	—	—	—	—	—	—
	5	3.7	110	170	280	440	690	1080	1350	1660	2040	2490	3050	3670	4440	5030	—	—	—	—
	7.5	5.5	0	0	200	310	490	770	960	1180	1450	1770	2170	2600	3150	3560	—	—	—	—
230	1/2	0.37	930	1490	2350	3700	5760	8910	—	—	—	—	—	—	—	—	—	—	—	—
	3/4	0.55	670	1080	1700	2580	4190	6490	8060	9860	—	—	—	—	—	—	—	—	—	—
	1	0.75	560	910	1430	2260	3520	5460	6780	8290	—	—	—	—	—	—	—	—	—	—
	1.5	1.1	420	670	1060	1670	2610	4050	5030	6160	7530	9170	—	—	—	—	—	—	—	—
	2	1.5	320	510	810	1280	2010	3130	3890	4770	5860	7170	8780	—	—	—	—	—	—	—
	3	2.2	240	390	620	990	1540	2400	2980	3660	4480	5470	6690	8020	9680	—	—	—	—	—
	5	3.7	140	230	370	590	920	1430	1790	2190	2690	3290	4030	4850	5870	6650	7560	8460	9220	—
	7.5	5.5	0	160	260	420	650	1020	1270	1560	1920	2340	2870	3440	4160	4710	5340	5970	6500	7510
380	1/2	0.37	2690	4290	6730	—	—	—	—	—	—	—	—	—	—	—	—	—	—	—
	3/4	0.55	2000	3190	5010	7860	—	—	—	—	—	—	—	—	—	—	—	—	—	—
	1	0.75	1620	2580	4060	6390	9980	—	—	—	—	—	—	—	—	—	—	—	—	—
	1.5	1.1	1230	1970	3100	4890	7630	—	—	—	—	—	—	—	—	—	—	—	—	—
	2	1.5	870	1390	2180	3450	5400	8380	—	—	—	—	—	—	—	—	—	—	—	—
	3	2.2	680	1090	1710	2690	4200	6500	8020	9830	—	—	—	—	—	—	—	—	—	—
	5	3.7	400	640	1010	1590	2490	3870	4780	5870	7230	8830	—	—	—	—	—	—	—	—
	7.5	5.5	270	440	690	1090	1710	2640	3260	4000	4930	6010	7290	8780	—	—	—	—	—	—
	10	7.5	200	320	510	800	1250	1930	2380	2910	3570	4330	5230	6260	7390	8280	9340	—	—	—
460	1/2	0.37	3770	6020	9460	—	—	—	—	—	—	—	—	—	—	—	—	—	—	—
	3/4	0.55	2730	4350	6850	—	—	—	—	—	—	—	—	—	—	—	—	—	—	—
	1	0.75	2300	3670	5770	9070	—	—	—	—	—	—	—	—	—	—	—	—	—	—
	1.5	1.1	1700	2710	4270	6730	—	—	—	—	—	—	—	—	—	—	—	—	—	—
	2	1.5	1300	2070	3270	5150	8050	—	—	—	—	—	—	—	—	—	—	—	—	—
	3	2.2	1000	1600	2520	3970	6200	—	—	—	—	—	—	—	—	—	—	—	—	—
	5	3.7	590	950	1500	2360	3700	5750	—	—	—	—	—	—	—	—	—	—	—	—
	7.5	5.5	420	680	1070	1690	2640	4100	5100	6260	7680	—	—	—	—	—	—	—	—	—
		10	7.5	310	500	790	1250	1960	3050	3800	4680	5750	7050	—	—	—	—	—	—	—
	15	11	0	340	540	850	1340	2090	2600	3200	3930	4810	5900	7110	—	—	—	—	—	

MOTOR, CABLE, & FUSE/CIRCUIT BREAKER REFERENCE
4-inch Motor, Cable, & Fuse/Circuit Breaker Reference

Table 37 (continued)

Motor Rating			Maximum Cable Length (ft) Measured from service entrance to motor																	
			AWG Copper Wire Size													MCM Copper Wire Size				
Volts	HP	KW	14	12	10	8	6	4	3	2	1	0	00	000	0000	250	300	350	400	500
575	1/2	0.37	5900	9410	—	—	—	—	—	—	—	—	—	—	—	—	—	—	—	—
	3/4	0.55	4270	6810	—	—	—	—	—	—	—	—	—	—	—	—	—	—	—	—
	1	0.75	3630	5800	9120	—	—	—	—	—	—	—	—	—	—	—	—	—	—	—
	1.5	1.1	2620	4180	6580	—	—	—	—	—	—	—	—	—	—	—	—	—	—	—
	2	1.5	2030	3250	5110	8060	—	—	—	—	—	—	—	—	—	—	—	—	—	—
	3	2.2	1580	2530	3980	6270	—	—	—	—	—	—	—	—	—	—	—	—	—	—
	5	3.7	920	1480	2330	3680	5750	—	—	—	—	—	—	—	—	—	—	—	—	—
	7.5	5.5	660	1060	1680	2650	4150	—	—	—	—	—	—	—	—	—	—	—	—	—
	10	7.5	490	780	1240	1950	3060	4770	5940	—	—	—	—	—	—	—	—	—	—	—

NOTE: If aluminum wire is used, it must be two sizes larger than copper wire and oxidation inhibitors must be used on connections.

NOTE: Shaded cells meet NEC ampacity requirements for only individual conductors in free air or water. Unshaded cells meet NEC ampacity requirements for either individual conductors or jacketed cable. See [“Cable Selection” on page 49](#).

MOTOR, CABLE, & FUSE/CIRCUIT BREAKER REFERENCE
4-inch Motor, Cable, & Fuse/Circuit Breaker Reference

4-inch / Three-Phase / 3-Lead / Encapsulated Motor Fuse Sizing

NOTE: Fuse and breaker sizing are the same for Franklin standard, G-Series, and 700-Series 4-inch motors.

Table 38.

Motor Model Prefix	Rating			Circuit Breakers or Fuse Amps (Maximum per NEC)			Circuit Breakers or Fuse Amps (Typical Submersible)		
	HP	KW	Volts	Standard Fuse	Dual Element Time Delay Fuse	Circuit Breaker	Standard Fuse	Dual Element Time Delay Fuse	Circuit Breaker
234904	1/2	0.37	48	30	17.5	25	30	12	25
234501			200	10	5	8	10	4	15
234511			230	8	4.5	6	8	4	15
234541			380	5	2.5	4	5	2	15
234521			460	4	2.25	3	4	2	15
234531			575	3	1.8	3	3	1.4	15
234902	3/4	0.55	100	20	12	20	20	8	20
234502			200	15	7	10	12	5	15
234512			230	10	5.6	8	10	5	15
234542			380	6	3.5	5	6	3	15
234522			460	5	2.8	4	5	3	15
234532			575	4	2.5	4	4	1.8	15
234503	1	0.75	200	15	8	15	15	6	15
234513			230	15	7	10	12	6	15
234543			380	8	4.5	8	8	4	15
234523			460	6	3.5	5	6	3	15
234533			575	5	2.8	4	5	2.5	15
234504			1.5	1.1	200	20	12	15	20
234514	230	15			9	15	15	8	15
234544	380	10			5.6	8	10	4	15
234524	460	8			4.5	8	8	4	15
234534	575	6			3.5	5	6	3	15
234305	2.0	1.5			200	25	15	20	25
234315			230	25	12	20	25	10	20
234345			380	15	8	15	15	6	15
234325			460	15	6	10	11	5	15
234335			575	10	5	8	10	4	15
234306			3.0	2.2	200	35	20	30	35
234316	230	30			17.5	25	30	12	25
234346	380	20			12	15	20	8	15
234326	460	15			9	15	15	6	15
234336	575	15			7	10	11	5	15
234307	5	3.7			200	60	35	50	60
234317			230	50	30	40	45	20	40
234347			380	30	17.5	25	30	12	25
234327			460	25	15	20	25	10	20
234337			575	20	12	20	20	8	20
234308			7.5	5.5	200	90	50	70	80
234318	230	80			45	60	70	30	60
234348	380	45			25	40	40	20	40
234328	460	40			25	30	35	15	30
234338	575	30			17.5	25	30	12	25

MOTOR, CABLE, & FUSE/CIRCUIT BREAKER REFERENCE
4-inch Motor, Cable, & Fuse/Circuit Breaker Reference

Table 38 (continued)

Motor Model Prefix	Rating			Circuit Breakers or Fuse Amps (Maximum per NEC)			Circuit Breakers or Fuse Amps (Typical Submersible)		
	HP	KW	Volts	Standard Fuse	Dual Element Time Delay Fuse	Circuit Breaker	Standard Fuse	Dual Element Time Delay Fuse	Circuit Breaker
234349	10	7.5	380	70	40	60	60	25	60
234329			460	60	30	45	50	25	45
234339			575	45	25	35	40	20	35
234549			380	70	35	60	60	25	60
234595			460	60	30	45	50	25	45
234598			575	45	25	35	40	20	35
234646	15	11	380	90	50	70	80	35	70
234626			460	80	45	60	70	30	60
234636			575	60	35	50	60	25	50

4-inch/Three-Phase/3-Lead/Encapsulated MagForce Motor Specs/3600 RPM

Table 39.

Type	Motor Model Prefix	Rating				Maximum Load		Winding Resistance (Ohms)	Efficiency % SF
		HP	KW	Volts	SF	Amps	Watts		
4-inch	234055	1.5	1.1	230	1.3	4.8	1700	2.9-3.5	85
	234052	2	1.5	230	1.25	6.4	2160	1.8-2.3	86
		3	2.2		1.15	8.1	2955		87
	234054	5	3.7	230	1.15	13.9	4750	.65-.79	90
	234064	5	3.7	460	1.15	6.9	4750	2.6-3.2	90
	234056	7.5	5.5	230	1.15	19.8	7105	.44-.54	90
		10	7.5			26.0	9460		
	234066	7.5	5.5	460	1.15	9.9	7105	1.8-2.2	90
10		7.5	13.0			9460			

4-inch/Three-Phase/3-Lead/Encapsulated MagForce Motor 75 °C Cable/3600 RPM

Table 40.

Motor Rating			Maximum Cable Length (ft) Measured from service entrance to motor												
Volts	HP	KW	AWG Copper Wire Size												
			14	12	10	8	6	4	3	2	1	0	00	000	0000
230	1.5	1.1	520	830	1320	2030	3160	4910	6020	7470	9150	—	—	—	—
	2	1.5	390	620	990	1520	2370	3680	4510	5600	6860	8360	—	—	—
	3	2.2	300	490	780	1200	1870	2910	3560	4420	5420	6610	8070	9680	—
	5	3.7	180	290	460	700	1100	1700	2090	2600	3180	3880	4740	5680	6800
	7.5	5.5	120	200	320	490	760	1190	1450	1810	2210	2700	3300	3960	4740
	10	7.5	0	150	240	370	580	900	1110	1380	1680	2060	2510	2010	3610
460	5	3.7	720	1160	1840	2820	4400	6830	8370	—	—	—	—	—	—
	7.5	5.5	500	810	1280	1970	3070	4760	5830	7240	8870	—	—	—	—
	10	7.5	380	610	970	1500	2330	3620	5520	6750	8240	—	—	—	—

NOTE: If aluminum wire is used, it must be two sizes larger than copper wire and oxidation inhibitors must be used on connections.

NOTE: Shaded cells meet NEC ampacity requirements for only individual conductors in free air or water. Unshaded cells meet NEC ampacity requirements for either individual conductors or jacketed cable. See [“Cable Selection” on page 49.](#)

MOTOR, CABLE, & FUSE/CIRCUIT BREAKER REFERENCE

4-inch Motor, Cable, & Fuse/Circuit Breaker Reference

4-inch / Three-Phase / Encapsulated MagForce Motor Fuse Sizing

MagForce motors must be used with Variable Frequency Drives. Contact Franklin Electric for further details.

6-inch Motor, Cable, & Fuse/Circuit Breaker Reference

6-inch / Single-Phase / 3-Lead / Encapsulated Motor Specs / 3450 RPM

Table 41.

Type	Motor Model Prefix	Rating				Full Load		Maximum Load		[1] Winding Res. in ohms M=Main Res. S=Start Res.	Efficiency %		Power Factor %		Locked Rotor Amps	kVA Code
		HP	KW	Volts	SF	[2] Amps	Watts	[2] Amps	Watts		SF	FL	SF	FL		
6"	[3] 226110	5	3.7	230	1.15	Y23.0 B14.3 R10.8	4910	Y27.5 B17.4 R10.5	5570	M.55-.68 S1.3-1.7	77	76	100	99	99	E
	226111	7.5	5.5		1.15	Y36.5 B34.4 R5.5	7300	Y42.1 B40.5 R5.4	8800	M.36-.50 S.88-1.1	73	74	91	90	165	F
	226112	10	7.5		1.15	Y44.0 B39.5 R9.3	9800	Y51.0 B47.5 R8.9	11300	M.27-.33 S.80-.99	76	77	96	96	204	E
	226113	15	11		1.15	Y62.0 B52.0 R17.5	13900	Y75.0 B62.5 R16.9	16200	M.17-.22 S.68-.93	79	80	97	98	303	E

1. M: Main winding = yellow to black; S: Start winding = yellow to red
2. Y: Yellow lead = line amps; B: Black lead = main winding amps; R: Red lead = start or auxiliary winding amps
3. Control Boxes date coded 01M and older have 60 MFD run capacitors and the current values on a 6-inch motor will be Y23.0 @ FL -Y27.5 @ Max Load.
 - B18.2; B23.2; R8.0; R7.8

NOTE: Performance is typical, not guaranteed, at specified voltages and capacitor values. Performance at voltage ratings not shown is similar, except amps vary inversely with voltage.

6-inch / Single-Phase / 3-Lead / 75 °C Cable

Table 42.

Motor Rating			AWG Copper Wire Size												
Volts	HP	KW	14	12	10	8	6	4	3	2	1	0	00	000	0000
230	5	3.7	0	110	180	280	450	710	890	1110	1390	1740	2170	2680	3330
	7.5	5.5	0	0	120	200	310	490	610	750	930	1140	1410	1720	2100
	10	7.5	0	0	0	160	250	390	490	600	750	930	1160	1430	1760
	15	11	0	0	0	0	170	270	340	430	530	660	820	1020	1260

NOTE: If aluminum wire is used, it must be two sizes larger than copper wire and oxidation inhibitors must be used on connections.

NOTE: Shaded cells meet the NEC ampacity requirements for only individual conductors in free air or water. Unshaded cells meet NEC ampacity requirements for either individual conductors or jacketed cable. See ["Cable Selection" on page 49.](#)

MOTOR, CABLE, & FUSE/CIRCUIT BREAKER REFERENCE
6-inch Motor, Cable, & Fuse/Circuit Breaker Reference

6-inch / Single-Phase / Encapsulated Motor Fuse Sizing

Table 43.

Type	Motor Model Prefix	Rating			Circuit Breaker or Fuse Amps					
		HP	KW	Volts	Maximum per NEC			Typical Submersible		
					Standard Fuse	Dual Element Time Delay Fuse	Circuit Breaker	Standard Fuse	Dual Element Time Delay Fuse	Circuit Breaker
6"	226110	5	3.7	230	80	45	60	70	30	60
	226111	7.5	5.5		125	70	100	110	50	100
	226112	10	7.5		150	80	125	150	60	125
	226113	15	11		200	125	175	200	90	175

MOTOR, CABLE, & FUSE/CIRCUIT BREAKER REFERENCE
6-inch Motor, Cable, & Fuse/Circuit Breaker Reference

6-inch / Three-Phase / 3-Lead / Encapsulated Motor Specs / 3450 PRM

Table 44.

Motor Model Prefix	Rating				Full Load		Maximum Load		Winding Resistance (Ohms)	Efficiency %		Locked Rotor Amps	kVA Code
	HP	KW	Volts	SF	Amps	Watts	Amps	Watts		SF	FL		
236650	5	3.7	200	1.15	17.5	4700	20.0	5400	.77-.93	79	79	99	H
236600			230		15		17.6		1.0-1.2			86	
236660			380		9.1		10.7		2.6-3.2			52	
236610			460		7.5		8.8		3.9-4.8			43	
236620			575		6		7.1		6.3-7.7			34	
236651	7.5	5.5	200	1.15	25.1	7000	28.3	8000	.43-.53	80	80	150	H
236601			230		21.8		24.6		.64-.78			130	
236661			380		13.4		15		1.6-2.1			79	
236611			460		10.9		12.3		2.4-2.9			65	
236621			575		8.7		9.8		3.7-4.6			52	
236652	10	7.5	200	1.15	32.7	9400	37	10800	.37-.45	79	79	198	H
236602			230		28.4		32.2		.47-.57			172	
236662			380		17.6		19.6		1.2-1.5			104	
236612			460		14.2		16.1		1.9-2.4			86	
236622			575		11.4		12.9		3.0-3.7			69	
236653	15	11	200	1.15	47.8	13700	54.4	15800	.24-.29	81	81	306	H
236603			230		41.6		47.4		.28-.35			266	
236663			380		25.8		28.9		.77-.95			161	
236613			460		20.8		23.7		1.1-1.4			133	
236623			575		16.6		19		1.8-2.3			106	
236654	20	15	200	1.15	61.9	18100	69.7	20900	.16-.20	82	82	416	J
236604			230		53.8		60.6		.22-.26			362	
236664			380		33.0		37.3		.55-.68			219	
236614			460		26.9		30.3		.8-1.0			181	
236624			575		21.5		24.2		1.3-1.6			145	
236655	25	18.5	200	1.15	77.1	22500	86.3	25700	.12-.15	83	83	552	J
236605			230		67.0		76.4		.15-.19			480	
236665			380		41.0		46.0		.46-.56			291	
236615			460		33.5		38.2		.63-.77			240	
236625			575		26.8		30.0		1.0-1.3			192	
236656	30	22	200	1.15	90.9	26900	104	31100	.09-.11	83	83	653	J
236606			230		79.0		90.4		.14-.17			568	
236666			380		48.8		55.4		.35-.43			317	
236616			460		39.5		45.2		.52-.64			284	
236626			575		31.6		36.2		.78-.95			227	
236667	40	30	380	1.15	66.5	35600	74.6	41400	.26-.33	83	83	481	J
236617			460		54.9		62.9		.34-.42			397	
236627			575		42.8		49.6		.52-.64			318	
236668	50	37	380	1.15	83.5	45100	95	52200	.21-.25	82	83	501	H
236618			460		67.7		77		.25-.32			414	
236628			575		54.2		61.6		.40-.49			331	
276668			380		82.4		94.5		.21-.25			501	
276618			460		68.1		78.1		.25-.32			414	
276628	575	54.5	62.5	.40-.49	331								
276029	60/50	45/37	380	1.15	98.1	53500	111.8	61700	.15-.18	84	84	627	H
276009			460		81.0		92.3		.22-.27			518	
276059			575		64.8		73.9		.35-.39			414	

MOTOR, CABLE, & FUSE/CIRCUIT BREAKER REFERENCE
6-inch Motor, Cable, & Fuse/Circuit Breaker Reference

Table 44 (continued)

Motor Model Prefix	Rating				Full Load		Maximum Load		Winding Resistance (Ohms)	Efficiency %		Locked Rotor Amps	kVA Code
	HP	KW	Volts	SF	Amps	Watts	Amps	Watts		SF	FL		
236669	60	45	380	1.15	98.7	53500	111	61700	.15-.18	84	84	627	H
236619			460		80.5		91		.22-.27			518	
236629			575		64.4		72.8		.35-.39			414	
276669			380		98.1		111.8		.15-.18			627	
276619			460		81.0		92.3		.22-.27			518	
276629			575		64.8		73.9		.35-.39			414	

NOTE: Model numbers above are for three-lead motors. Six-lead motors with different model numbers have the same running performance, but when Wye connected for starting draw 33% of the values shown. Six-lead individual phase resistance = table X 1.5.

6-inch/Three-Phase/3-Lead/Encapsulated Motor Specs Hi-Temp (90 °C)/3450 RPM

Table 45.

Motor Model Prefix	Rating				Full Load		Maximum Load		Winding Resistance (Ohms)	Efficiency %		Locked Rotor Amps	kVA Code
	HP	KW	Volts	SF	Amps	Watts	Amps	Watts		SF	FL		
276650	5	3.7	200	1.15	17.2	5200	19.8	5800	.53-.65	73	72	124	K
276600			230		15.0		17.2		.68-.84			108	
276660			380		9.1		10.4		2.0-2.4			66	
276610			460		7.5		8.6		2.8-3.4			54	
276620			575		6.0		6.9		4.7-5.7			43	
276651	7.5	5.5	200	1.15	24.8	7400	28.3	8400	.30-.37	77	76	193	K
276601			230		21.6		24.6		.41-.50			168	
276661			380		13.1		14.9		1.1-1.4			102	
276611			460		10.8		12.3		1.7-2.0			84	
276621			575		8.6		9.9		2.6-3.2			67	
276652	10	7.5	200	1.15	32.0	9400	36.3	10700	.21-.26	80	79	274	L
276602			230		27.8		31.6		.28-.35			238	
276662			380		16.8		19.2		.80-.98			144	
276612			460		13.9		15.8		1.2-1.4			119	
276622			575		11.1		12.7		1.8-2.2			95	
276653	15	11	200	1.15	48.5	14000	54.5	15900	.15-.19	81	80	407	L
276603			230		42.2		47.4		.19-.24			354	
276663			380		25.5		28.7		.52-.65			214	
276613			460		21.1		23.7		.78-.96			177	
276623			575		16.9		19.0		1.2-1.4			142	
276654	20	15	200	1.15	64.9	18600	73.6	21300	.10-.12	80	80	481	K
276604			230		56.4		64.0		.14-.18			418	
276664			380		34.1		38.8		.41-.51			253	
276614			460		28.2		32.0		.58-.72			209	
276624			575		22.6		25.6		.93-1.15			167	
276655	25	18.5	200	1.15	80	22600	90.6	25800	.09-.11	83	82	665	L
276605			230		69.6		78.8		.11-.14			578	
276665			380		42.1		47.7		.27-.34			350	
276615			460		34.8		39.4		.41-.51			289	
276625			575		27.8		31.6		.70-.86			231	

MOTOR, CABLE, & FUSE/CIRCUIT BREAKER REFERENCE
6-inch Motor, Cable, & Fuse/Circuit Breaker Reference

Table 45 (continued)

Motor Model Prefix	Rating				Full Load		Maximum Load		Winding Resistance (Ohms)	Efficiency %		Locked Rotor Amps	kVA Code
	HP	KW	Volts	SF	Amps	Watts	Amps	Watts		SF	FL		
276656	30	22	200	1.15	95.0	28000	108.6	31900	.07-.09	81	80	736	K
276606			230		82.6		94.4		.09-.12			640	
276666			380		50.0		57.2		.23-.29			387	
276616			460		41.3		47.2		.34-.42			320	
276626			575		33.0		37.8		.52-.65			256	
276667			380		67.2		76.0		.18-.23			545	
276617	40	30	460	1.15	55.4	35900	62.8	42400	.23-.29	84	83	450	L
276627			575		45.2		50.2		.34-.43			360	

NOTE: Model numbers above are for three-lead motors. Six-lead motors with different model numbers have the same running performance, but when Wye connected for starting draw 33% of the values shown. Six-lead individual phase resistance = table X 1.5.

6-inch / Three-Phase / 6-Lead / Encapsulated Motor Specs / 3450 RPM

Table 46.

Type	Motor Model Prefix	Rating				Full Load		Maximum Load		Winding Resistance (Ohms)	Efficiency %		Locked Rotor Amps	kVA Code
		HP	KW	Volts	SF	Amps	Watts	Amps	Watts		SF	FL		
6-inch	236767	40	30	200	1.15	127	35600	142	41400	.064-.078	83	83	913	J
	236727			230		110		124		.090-.110			794	
	236768	50	37	200		159	45100	181	52200	.050-.062	82	83	952	H
	236728			230		138		157		.067-.081			828	
	236729	60	45	163		54400	184	62700	.057-.070	82	82	1036		

6-inch / Three-Phase / 3-Lead / 75 °C Cable

Table 47.

Motor Rating			Maximum Cable Length (ft) Measured from service entrance to motor																	
			AWG Copper Wire Size													MCM Copper Wire Size				
Volts	HP	KW	14	12	10	8	6	4	3	2	1	0	00	000	000-0	250	300	350	400	500
200	5	3.7	110	170	280	440	690	1080	1350	1660	2040	2490	3050	3670	4440	5030	—	—	—	—
	7.5	5.5	0	0	200	310	490	770	960	1180	1450	1770	2170	2600	3150	3560	—	—	—	—
	10	7.5	0	0	150	230	370	570	720	880	1090	1330	1640	1970	2390	2720	3100	3480	3800	4420
	15	11	0	0	0	160	250	390	490	600	740	910	1110	1340	1630	1850	2100	2350	2570	2980
	20	15	0	0	0	0	190	300	380	460	570	700	860	1050	1270	1440	1650	1850	2020	2360
	25	18.5	0	0	0	0	0	240	300	370	460	570	700	840	1030	1170	1330	1500	1640	1900
230	5	3.7	140	230	370	590	920	1430	1790	2190	2690	3290	4030	4850	5870	6650	7560	8460	9220	—
	7.5	5.5	0	160	260	420	650	1020	1270	1560	1920	2340	2870	3440	4160	4710	5340	5970	6500	7510
	10	7.5	0	0	190	310	490	760	950	1170	1440	1760	2160	2610	3160	3590	4100	4600	5020	5840
	15	11	0	0	0	210	330	520	650	800	980	1200	1470	1780	2150	2440	2780	3110	3400	3940
	20	15	0	0	0	160	250	400	500	610	760	930	1140	1380	1680	1910	2180	2450	2680	3120
	25	18.5	0	0	0	0	200	320	400	500	610	750	920	1120	1360	1540	1760	1980	2160	2520
30	22	0	0	0	0	0	260	330	410	510	620	760	930	1130	1280	1470	1650	1800	2110	

MOTOR, CABLE, & FUSE/CIRCUIT BREAKER REFERENCE
6-inch Motor, Cable, & Fuse/Circuit Breaker Reference

Table 47 (continued)

Motor Rating			Maximum Cable Length (ft) Measured from service entrance to motor																	
			AWG Copper Wire Size													MCM Copper Wire Size				
Volts	HP	KW	14	12	10	8	6	4	3	2	1	0	00	000	000-0	250	300	350	400	500
380	5	3.7	400	640	1010	1590	2490	3870	4780	5870	7230	8830	—	—	—	—	—	—	—	—
	7.5	5.5	270	440	690	1090	1710	2640	3260	4000	4930	6010	7290	8780	—	—	—	—	—	—
	10	7.5	200	320	510	800	1250	1930	2380	2910	3570	4330	5230	6260	7390	8280	9340	—	—	—
	15	11	0	0	370	590	920	1430	1770	2170	2690	3290	4000	4840	5770	6520	7430	8250	8990	—
	20	15	0	0	280	440	700	1090	1350	1670	2060	2530	3090	3760	4500	5110	2840	6510	7120	8190
	25	18.5	0	0	0	360	570	880	1100	1350	1670	2050	2510	3040	3640	4130	4720	5250	5740	6590
	30	22	0	0	0	290	470	730	910	1120	1380	1700	2080	2520	3020	3430	3920	4360	4770	5490
	40	30	0	0	0	0	0	530	660	820	1010	1240	1520	1840	2200	2500	2850	3170	3470	3990
	50	37	0	0	0	0	0	440	540	660	820	1000	1220	1480	1770	2010	2290	2550	2780	3190
	60	45	0	0	0	0	0	370	460	560	690	850	1030	1250	1500	1700	1940	2150	2350	2700
460	5	3.7	590	950	1500	2360	3700	5750	—	—	—	—	—	—	—	—	—	—	—	
	7.5	5.5	420	680	1070	1690	2640	4100	5100	6260	7680	—	—	—	—	—	—	—	—	
	10	7.5	310	500	790	1250	1960	3050	3800	4680	5750	7050	—	—	—	—	—	—	—	
	15	11	0	340	540	850	1340	2090	2600	3200	3930	4810	5900	7110	—	—	—	—	—	
	20	15	0	0	410	650	1030	1610	2000	2470	3040	3730	4580	5530	—	—	—	—	—	
	25	18.5	0	0	330	530	830	1300	1620	1990	2450	3010	3700	4470	5430	—	—	—	—	
	30	22	0	0	270	430	680	1070	1330	1640	2030	2490	3060	3700	4500	5130	5860	—	—	
	40	30	0	0	0	320	500	790	980	1210	1490	1830	2250	2710	3290	3730	4250	—	—	
	50	37	0	0	0	0	410	640	800	980	1210	1480	1810	2190	2650	3010	3420	3830	4180	4850
	60	45	0	0	0	0	0	540	670	830	1020	1250	1540	1850	2240	2540	2890	3240	3540	4100
575	5	3.7	920	1480	2330	3680	5750	—	—	—	—	—	—	—	—	—	—	—	—	
	7.5	5.5	660	1060	1680	2650	4150	—	—	—	—	—	—	—	—	—	—	—	—	
	10	7.5	490	780	1240	1950	3060	4770	5940	—	—	—	—	—	—	—	—	—	—	
	15	11	330	530	850	1340	2090	3260	4060	—	—	—	—	—	—	—	—	—	—	
	20	15	0	410	650	1030	1610	2520	3140	3860	4760	5830	—	—	—	—	—	—	—	
	25	18.5	0	0	520	830	1300	2030	2530	3110	3840	4710	—	—	—	—	—	—	—	
	30	22	0	0	430	680	1070	1670	2080	2560	3160	3880	4770	5780	7030	8000	—	—	—	
	40	30	0	0	0	500	790	1240	1540	1900	2330	2860	3510	4230	5140	5830	—	—	—	
	50	37	0	0	0	410	640	1000	1250	1540	1890	2310	2840	3420	4140	4700	5340	5990	6530	7580
	60	45	0	0	0	0	540	850	1060	1300	1600	1960	2400	2890	3500	3970	4520	5070	5530	6410

NOTE: If aluminum wire is used, it must be two sizes larger than copper wire and oxidation inhibitors must be used on connections.

NOTE: Shaded cells meet NEC ampacity requirements for only individual conductors in free air or water. Unshaded cells meet NEC ampacity requirements for either individual conductors or jacketed cable. See [“Cable Selection” on page 49.](#)

MOTOR, CABLE, & FUSE/CIRCUIT BREAKER REFERENCE
6-inch Motor, Cable, & Fuse/Circuit Breaker Reference

6-inch / Three-Phase / 6-Lead / 75 °C Cable

Table 48.

Motor Rating			Maximum Cable Length (ft) Measured from service entrance to motor																	
			AWG Copper Wire Size													MCM Copper Wire Size				
Volts	HP	KW	14	12	10	8	6	4	3	2	1	0	00	000	0000	250	300	350	400	500
200	5	3.7	160	250	420	660	1030	1620	2020	2490	3060	3730	4570	5500	6660	7540	—	—	—	—
	7.5	5.5	110	180	300	460	730	1150	1440	1770	2170	2650	3250	3900	4720	5340	—	—	—	—
	10	7.5	80	130	210	340	550	850	1080	1320	1630	1990	2460	2950	3580	4080	4650	5220	5700	6630
	15	11	0	0	140	240	370	580	730	900	1110	1360	1660	2010	2440	2770	3150	3520	3850	4470
	20	15	0	0	120	170	280	450	570	690	850	1050	1290	1570	1900	2160	2470	2770	3030	3540
	25	18.5	0	0	0	140	220	360	450	550	690	850	1050	1260	1540	1750	1990	2250	2460	2850
	30	22	0	0	0	120	180	294	370	460	570	700	870	1050	1270	1450	1660	1870	2040	2380
	40	30	0	0	0	0	130	220	270	330	420	510	630	760	910	1050	1200	1350	1470	1710
	50	37	0	0	0	0	0	180	210	270	330	420	510	610	730	840	960	1080	1170	1360
60	45	0	0	0	0	0	0	180	220	280	340	420	510	630	720	810	910	990	1150	
230	5	3.7	210	340	550	880	1380	2140	2680	3280	4030	4930	6040	7270	8800	9970	—	—	—	—
	7.5	5.5	150	240	390	630	970	1530	1900	2340	2880	3510	4300	5160	6240	7060	8010	8950	9750	—
	10	7.5	110	180	280	460	730	1140	1420	1750	2160	2640	3240	3910	4740	5380	6150	6900	7530	8760
	15	11	0	130	190	310	490	780	970	1200	1470	1800	2200	2670	3220	3660	4170	4660	5100	5910
	20	15	0	0	140	230	370	600	750	910	1140	1390	1710	2070	2520	2860	3270	3670	4020	4680
	25	18.5	0	0	120	190	300	480	600	750	910	1120	1380	1680	2040	2310	2640	2970	3240	3780
	30	22	0	0	0	150	240	390	490	610	760	930	1140	1390	1690	1920	2200	2470	2700	3160
	40	30	0	0	0	0	180	280	360	450	550	670	840	1000	1210	1390	1590	1780	1950	2260
	50	37	0	0	0	0	150	240	280	360	450	550	670	810	970	1120	1270	1420	1560	1810
60	45	0	0	0	0	0	190	240	300	370	460	570	690	820	940	1080	1210	1320	1530	
380	5	3.7	600	960	1510	2380	3730	5800	7170	8800	—	—	—	—	—	—	—	—	—	—
	7.5	5.5	400	660	1030	1630	2560	3960	4890	6000	7390	9010	—	—	—	—	—	—	—	—
	10	7.5	300	480	760	1200	1870	2890	3570	4360	5350	6490	7840	9390	—	—	—	—	—	—
	15	11	210	340	550	880	1380	2140	2650	3250	4030	4930	6000	7260	8650	9780	—	—	—	—
	20	15	160	260	410	660	1050	1630	2020	2500	3090	3790	4630	5640	6750	7660	4260	9760	—	—
	25	18.5	0	210	330	540	850	1320	1650	2020	2500	3070	3760	4560	5460	6190	7080	7870	8610	9880
	30	22	0	0	270	430	700	1090	1360	1680	2070	2550	3120	3780	4530	5140	5880	6540	7150	8230
	40	30	0	0	210	320	510	790	990	1230	1510	1860	2280	2760	3300	3750	4270	4750	5200	5980
	50	37	0	0	0	250	400	630	810	990	1230	1500	1830	2220	2650	3010	3430	3820	4170	4780
60	45	0	0	0	0	340	540	660	840	1030	1270	1540	1870	2250	2550	2910	3220	3520	4050	
460	5	3.7	880	1420	2250	3540	5550	8620	—	—	—	—	—	—	—	—	—	—	—	—
	7.5	5.5	630	1020	1600	2530	3960	6150	7650	9390	—	—	—	—	—	—	—	—	—	—
	10	7.5	460	750	1180	1870	2940	4570	5700	7020	8620	—	—	—	—	—	—	—	—	—
	15	11	310	510	810	1270	2010	3130	3900	4800	5890	7210	8850	—	—	—	—	—	—	—
	20	15	230	380	610	970	1540	2410	3000	3700	4560	5590	6870	8290	—	—	—	—	—	—
	25	18.5	190	310	490	790	1240	1950	2430	2980	3670	4510	5550	6700	8140	—	—	—	—	—
	30	22	0	250	410	640	1020	1600	1990	2460	3040	3730	4590	5550	6750	7690	8790	—	—	—
	40	30	0	0	300	480	750	1180	1470	1810	2230	2740	3370	4060	4930	5590	6370	—	—	—
	50	37	0	0	250	370	590	960	1200	1470	1810	2220	2710	3280	3970	4510	5130	5740	6270	7270
60	45	0	0	0	320	500	810	1000	1240	1530	1870	2310	2770	3360	3810	4330	4860	5310	6150	

MOTOR, CABLE, & FUSE/CIRCUIT BREAKER REFERENCE
6-inch Motor, Cable, & Fuse/Circuit Breaker Reference

Table 48 (continued)

Motor Rating			Maximum Cable Length (ft) Measured from service entrance to motor																		
			AWG Copper Wire Size													MCM Copper Wire Size					
Volts	HP	KW	14	12	10	8	6	4	3	2	1	0	00	000	0000	250	300	350	400	500	
575	5	3.7	1380	2220	3490	5520	8620	—	—	—	—	—	—	—	—	—	—	—	—	—	—
	7.5	5.5	990	1590	2520	3970	6220	—	—	—	—	—	—	—	—	—	—	—	—	—	—
	10	7.5	730	1170	1860	2920	4590	7150	8910	—	—	—	—	—	—	—	—	—	—	—	—
	15	11	490	790	1270	2010	3130	4890	6090	—	—	—	—	—	—	—	—	—	—	—	—
	20	15	370	610	970	1540	2410	3780	4710	5790	7140	8740	—	—	—	—	—	—	—	—	—
	25	18.5	300	490	780	1240	1950	3040	3790	4660	5760	7060	—	—	—	—	—	—	—	—	—
	30	22	240	400	645	1020	1600	2500	3120	3840	4740	5820	7150	8670	—	—	—	—	—	—	—
	40	30	0	300	480	750	1180	1860	2310	2850	3490	4290	5260	6340	7710	8740	—	—	—	—	—
	50	37	0	0	380	590	960	1500	1870	2310	2830	3460	4260	5130	6210	7050	8010	8980	9790	—	—
	60	45	0	0	330	500	790	1270	1590	1950	2400	2940	3600	4330	5250	5950	6780	7600	8290	9610	—

NOTE: If aluminum wire is used, it must be two sizes larger than copper wire and oxidation inhibitors must be used on connections.

NOTE: Shaded cells meet NEC ampacity requirements for only individual conductors in free air or water. Unshaded cells meet NEC ampacity requirements for either individual conductors or jacketed cable. See [“Cable Selection” on page 49.](#)

6-inch/Three-Phase/3-Lead /Standard & Hi-Temp (90 °C) Encapsulated Motor Fuse Sizing

Table 49.

Motor Model Prefix		Rating			Circuit Breakers or Fuse Amps (Maximum per NEC)			Circuit Breakers or Fuse Amps (Typical Submersible)		
Standard	Hi-Temp	HP	KW	Volts	Standard Fuse	Dual Element Time Delay Fuse	Circuit Breaker	Standard Fuse	Dual Element Time Delay Fuse	Circuit Breaker
236650	276650	5	3.7	200	60	35	45	50	25	45
236600	276600			230	45	30	40	45	20	40
236660	276660			380	30	17.5	25	30	12	25
236610	276610			460	25	15	20	25	10	20
236620	276620			575	20	12	15	20	8	15
236651	276651	7.5	5.5	200	80	45	70	80	35	70
236601	276601			230	70	40	60	70	30	60
236661	276661			380	45	25	35	40	20	35
236611	276611			460	35	20	30	35	15	30
236621	276621			575	30	17.5	25	25	11	25
236652	276652	10	7.5	200	100	60	90	100	45	90
236602	276602			230	90	50	80	90	40	80
236662	276662			380	60	35	45	50	25	45
236612	276612			460	45	25	40	45	20	40
236622	276622			575	35	20	30	35	15	30
236653	276653	15	11	200	150	90	125	150	60	125
236603	276603			230	150	80	110	125	60	110
236663	276663			380	80	50	70	80	35	70
236613	276613			460	70	40	60	60	30	60
236623	276623			575	60	30	45	50	25	45

MOTOR, CABLE, & FUSE/CIRCUIT BREAKER REFERENCE
6-inch Motor, Cable, & Fuse/Circuit Breaker Reference

Table 49 (continued)

Motor Model Prefix		Rating			Circuit Breakers or Fuse Amps (Maximum per NEC)			Circuit Breakers or Fuse Amps (Typical Submersible)		
Standard	Hi-Temp	HP	KW	Volts	Standard Fuse	Dual Element Time Delay Fuse	Circuit Breaker	Standard Fuse	Dual Element Time Delay Fuse	Circuit Breaker
236654	276654	20	15	200	200	110	175	175	80	175
236604	276604			230	175	100	150	175	70	150
236664	276664			380	100	60	90	100	45	90
236614	276614			460	90	50	70	80	35	70
236624	276624			575	70	40	60	70	30	60
236655	276655	25	18.5	200	250	150	200	225	100	200
236605	276605			230	225	125	175	200	90	175
236665	276665			380	125	80	110	125	50	110
236615	276615			460	110	60	90	100	45	90
236625	276625			575	90	50	70	80	35	70
236656	276656	30	22	200	300	175	250	300	125	250
236606	276606			230	250	150	225	250	100	200
236666	276666			380	150	90	125	150	60	125
236616	276616			460	125	70	110	125	50	100
236626	276626			575	100	60	90	100	40	80
236667	276667	40	30	380	200	125	175	200	90	175
236617	276617			460	175	100	150	175	70	150
236627	276627			575	150	80	110	125	60	110
236668	276668	50	37	380	250	150	225	250	110	225
236618	276618			460	225	125	175	200	90	175
236628	276628			575	175	100	150	175	70	150
236669	276669	60	45	380	300	175	250	300	125	250
236619	276619			460	250	150	225	250	100	225
236629	276629			575	200	125	175	200	80	175

6-inch /Three-Phase / 6-Lead / Encapsulated Motor Fuse Sizing

Table 50.

Motor Model Prefix Standard	Rating				Circuit Breakers or Fuse Amps					
	HP	KW	Volts	SF	Maximum per NEC			Typical Submersible		
					Standard Fuse	Dual Element Time Delay Fuse	Circuit Breaker	Standard Fuse	Dual Element Time Delay Fuse	Circuit Breaker
236767	40	30	200	1.15	400	225	350	400	175	350
236727			230		350	200	300	350	150	300
236768	50	37	200		500	300	400	450	200	400
236728			230		450	250	350	400	175	350
236729	60	45	230		500	300	450	500	225	450

MOTOR, CABLE, & FUSE/CIRCUIT BREAKER REFERENCE
6-inch Motor, Cable, & Fuse/Circuit Breaker Reference

6-inch/Three-Phase/3-Lead/Encapsulated MagForce Motor Specs/3600 RPM

Table 51.

Type	Motor Model Prefix	Rating				Maximum Load		Winding Resistance (Ohms)	Efficiency %
		HP	KW	Volts	SF	Amps	Watts		
6-inch	236080	7.5	5.5	460	1.15	11.6	7305	.76-.94	88
		10	7.5			14.2	9545		90
		15	11			20.5	14160		
	236084	20	15			28.9	18835	.30-.37	91
		25	18.5			34.6	23380		92
		30	22			41.0	28000		
	236086	40	30			56.5	37270	.17-.22	92
		50	37			69.2	46490		
		60	45			80.0	55970		

6-inch/Three-Phase/3-Lead/Encapsulated MagForce Motor 75 °C Cable/3600 RPM

Table 52.

Motor Rating			Maximum Cable Length (ft) Measured from service entrance to motor																							
Volts	HP	KW	AWG Copper Wire Size													MCM Copper Wire Size										
			14	12	10	8	6	4	3	2	1	0	00	000	0000	250	300	350	400	500	600	700	750	800		
460	7.5	5.5	430	690	1090	1680	2620	4060	4980	6180	7570	9230	—	—	—	—	—	—	—	—	—	—	—	—	—	—
	10	7.5	350	560	890	1370	2140	3320	4070	5050	6180	7540	9210	—	—	—	—	—	—	—	—	—	—	—	—	—
	15	11	240	390	610	950	1480	2290	2820	3500	4280	5220	6380	7650	9150	—	—	—	—	—	—	—	—	—	—	—
	20	15	0	270	430	670	1050	1630	2000	2480	3040	3700	4520	5420	6490	7390	8370	9350	—	—	—	—	—	—	—	—
	25	18.5	0	0	360	560	870	1360	1670	2070	2530	3090	3780	4530	5420	6170	6990	7810	8480	9790	—	—	—	—	—	—
	30	22	0	0	300	470	740	1140	1410	1750	2140	2610	3190	3820	4570	5210	5900	6590	7160	8260	9110	9810	—	—	—	—
	40	30	0	0	0	340	530	830	1020	1270	1550	1890	2310	2770	3320	3780	4280	4780	5190	5990	6610	7120	7360	7570	—	—
	50	37	0	0	0	0	430	680	830	1030	1260	1540	1890	2260	2710	3080	3490	3900	4240	4890	5390	5810	6010	6180	—	—
	60	45	0	0	0	0	0	580	720	890	1090	1330	1630	1960	2340	2670	3020	3380	3670	4230	4660	5030	5200	5340	—	—

NOTE: If aluminum wire is used, it must be two sizes larger than copper wire and oxidation inhibitors must be used on connections.

NOTE: Shaded cells meet NEC ampacity requirements for only individual conductors in free air or water. Unshaded cells meet NEC ampacity requirements for either individual conductors or jacketed cable. See [“Cable Selection” on page 49.](#)

6-inch / Three-Phase / Encapsulated MagForce Motor Fuse Sizing

MagForce motors must be used with Variable Frequency Drives. Contact Franklin Electric for further details.

8-inch Motor, Cable, & Fuse/Circuit Breaker Reference

8-inch / Three-Phase / 3-Lead / Encapsulated Motor Specs / 3525 RPM

Table 53.

Motor Model Prefix	Rating			Full Load		Maximum Load		Winding Resistance (Ohms)	Efficiency %		Locked Rotor Amps	kVA Code	
	HP	KW	Volts	SF	Amps	KW	Amps		KW	SF			FL
239660	40	30	380	1.15	64	35	72	40	.16-.20	86	86	479	J
239600			460		53		60		.24-.30			396	
239610			575		42		48		.39-.49			317	
239661	50	37	380	1.15	79	43	88	49	.12-.16	87	87	656	K
239601			460		64		73		.18-.22			542	
239611			575		51		59		.28-.34			434	
239662	60	45	380	1.15	92	52	104	60	.09-.11	88	87	797	K
239602			460		76		86		.14-.17			658	
239612			575		61		69		.22-.28			526	
239663	75	55	380	1.15	114	64	130	73.5	.06-.09	88	88	1046	L
239603			460		94		107		.10-.13			864	
239613			575		76		86		.16-.21			691	
239664	100	75	380	1.15	153	85	172	97.5	.05-.06	89	89	1466	L
239604			460		132		148		.07-.09			1211	
239614			575		101		114		.11-.13			969	
239165	125	93	380	1.15	202	109	228	125	.03-.04	87	86	1596	K
239105			460		167		188		.05-.07			1318	
239115			575		134		151		.08-.11			1054	
239166	150	110	380	1.15	235	128	266	146	.02-.03	88	87	1961	K
239106			460		194		219		.04-.05			1620	
239116			575		164		182		.06-.08			1296	
239167	175	130	380	1.15	265	150	302	173	.02-.04	88	88	1991	J
239107			460		219		249		.04-.05			1645	
239117			575		175		200		.06-.08			1316	
239168	200	150	380	1.15	298	169	342	194	.02-.03	88	88	2270	J
239108			460		246		282		.03-.05			1875	
239118			575		197		226		.05-.07			1500	

NOTE: Model numbers above are for three-lead motors. Six-lead motors with different model numbers have the same running performance, but when Wye connected for starting draw 33% of the values shown. Six-lead individual phase resistance = table X 1.5.

MOTOR, CABLE, & FUSE/CIRCUIT BREAKER REFERENCE
8-inch Motor, Cable, & Fuse/Circuit Breaker Reference

8-inch/Three-Phase/3-Lead/Encapsulated Motor Specs Hi-Temp (75 °C)/3525 RPM

Table 54.

Motor Model Prefix	Rating				Full Load		Maximum Load		Winding Resistance (Ohms)	Efficiency %		Locked Rotor Amps	kVA Code
	HP	KW	Volts	SF	Amps	KW	Amps	KW		SF	FL		
279160	40	30	380	1.15	69.9	38	78.7	43	.11-.14	79	78	616	M
279100			460		57.5		65.0		.16-.19			509	
279110			575		46.0		52.0		.25-.31			407	
279161	50	37	380	1.15	84.3	47	95.4	53	.07-.09	81	80	832	M
279101			460		69.6		78.8		.11-.14			687	
279111			575		55.7		63.0		.18-.22			550	
279162	60	45	380	1.15	98.4	55	112	62	.06-.07	83	82	1081	N
279102			460		81.3		92.1		.09-.11			893	
279112			575		65.0		73.7		.13-.16			715	
279163	75	56	380	1.15	125	68	141	77	.05-.06	83	82	1175	L
279103			460		100		114		.07-.09			922	
279113			575		80		92		.11-.14			738	
279164	100	75	380	1.15	159	88	181	100	.04-.05	86	85	1508	M
279104			460		131		149		.05-.07			1246	
279114			575		105		119		.08-.10			997	
279165	125	93	380	1.15	195	109	223	125	.03-.04	86	85	1793	L
279105			460		161		184		.04-.06			1481	
279115			575		129		148		.07-.09			1185	
279166	150	110	380	1.15	235	133	269	151	.02-.03	85	84	2012	K
279106			460		194		222		.03-.05			1662	
279116			575		155		178		.05-.07			1330	

NOTE: Model numbers above are for three-lead motors. Six-lead motors with different model numbers have the same running performance, but when Wye connected for starting draw 33% of the values shown. Six-lead individual phase resistance = table X 1.5.

8-inch / Three-Phase / 3-Lead / 75 °C Cable

Table 55.

Motor Rating			Maximum Cable Length (ft) Measured from service entrance to motor																	
			AWG Copper Wire Size													MCM Copper Wire Size				
Volts	HP	KW	14	12	10	8	6	4	3	2	1	0	00	000	0000	250	300	350	400	500
380	40	30	0	0	0	0	0	530	660	820	1010	1240	1520	1840	2200	2500	2850	3170	3470	3990
	50	37	0	0	0	0	0	440	540	660	820	1000	1220	1480	1770	2010	2290	2550	2780	3190
	60	45	0	0	0	0	0	370	460	560	690	850	1030	1250	1500	1700	1940	2150	2350	2700
	75	55	0	0	0	0	0	0	0	460	570	700	860	1050	1270	1440	1660	1850	2030	2350
	100	75	0	0	0	0	0	0	0	0	420	510	630	760	910	1030	1180	1310	1430	1650
	125	93	0	0	0	0	0	0	0	0	0	0	510	620	740	840	950	1060	1160	1330
	150	110	0	0	0	0	0	0	0	0	0	0	0	520	620	700	790	880	960	1090
	175	130	0	0	0	0	0	0	0	0	0	0	0	0	560	650	750	840	920	1070
	200	150	0	0	0	0	0	0	0	0	0	0	0	0	0	550	630	700	760	880
460	40	30	0	0	0	320	500	790	980	1210	1490	1830	2250	2710	3290	3730	4250	—	—	—
	50	37	0	0	0	0	410	640	800	980	1210	1480	1810	2190	2650	3010	3420	3830	4180	4850
	60	45	0	0	0	0	0	540	670	830	1020	1250	1540	1850	2240	2540	2890	3240	3540	4100
	75	55	0	0	0	0	0	440	550	680	840	1030	1260	1520	1850	2100	2400	2700	2950	3440
	100	75	0	0	0	0	0	0	0	500	620	760	940	1130	1380	1560	1790	2010	2190	2550
	125	93	0	0	0	0	0	0	0	0	0	600	740	890	1000	1220	1390	1560	1700	1960
	150	110	0	0	0	0	0	0	0	0	0	0	630	760	920	1050	1190	1340	1460	1690
	175	130	0	0	0	0	0	0	0	0	0	0	0	670	810	930	1060	1190	1300	1510
	200	150	0	0	0	0	0	0	0	0	0	0	0	590	710	810	920	1030	1130	1310
575	40	30	0	0	0	500	790	1240	1540	1900	2330	2860	3510	4230	5140	5830	—	—	—	—
	50	37	0	0	0	410	640	1000	1250	1540	1890	2310	2840	3420	4140	4700	5340	5990	6530	7580
	60	45	0	0	0	0	540	850	1060	1300	1600	1960	2400	2890	3500	3970	4520	5070	5530	6410
	75	55	0	0	0	0	0	690	860	1060	1310	1600	1970	2380	2890	3290	3750	5220	4610	5370
	100	75	0	0	0	0	0	0	640	790	970	1190	1460	1770	2150	2440	2790	3140	3430	3990
	125	93	0	0	0	0	0	0	0	630	770	950	1160	1400	1690	1920	2180	2440	2650	3070
	150	110	0	0	0	0	0	0	0	0	660	800	990	1190	1440	1630	1860	2080	2270	2640
	175	130	0	0	0	0	0	0	0	0	0	700	870	1050	1270	1450	1650	1860	2030	2360
	200	150	0	0	0	0	0	0	0	0	0	0	760	920	1110	1260	1440	1620	1760	2050

NOTE: If aluminum wire is used, it must be two sizes larger than copper wire and oxidation inhibitors must be used on connections.

NOTE: Shaded cells meet NEC ampacity requirements for only individual conductors in free air or water. Unshaded cells meet NEC ampacity requirements for either individual conductors or jacketed cable. See [“Cable Selection” on page 49.](#)

MOTOR, CABLE, & FUSE/CIRCUIT BREAKER REFERENCE
8-inch Motor, Cable, & Fuse/Circuit Breaker Reference

8-inch / Three-Phase / 6-Lead / 75 °C Cable

Table 56.

Motor Rating			Maximum Cable Length (ft) Measured from service entrance to motor																	
			AWG Copper Wire Size													MCM Copper Wire Size				
Volts	HP	KW	14	12	10	8	6	4	3	2	1	0	00	000	0000	250	300	350	400	500
380	40	30	0	0	210	320	510	790	990	1230	1510	1860	2280	2760	3300	3750	4270	4750	5200	5980
	50	37	0	0	0	250	400	630	810	990	1230	1500	1830	2220	2650	3010	3430	3820	4170	4780
	60	45	0	0	0	0	340	540	660	840	1030	1270	1540	1870	2250	2550	2910	3220	3520	4050
	75	55	0	0	0	0	290	450	550	690	855	1050	1290	1570	1900	2160	2490	2770	3040	3520
	100	75	0	0	0	0	0	340	420	520	640	760	940	1140	1360	1540	1770	1960	2140	2470
	125	93	0	0	0	0	0	0	340	400	490	600	730	930	1110	1260	1420	1590	1740	1990
	150	110	0	0	0	0	0	0	0	350	420	510	620	750	930	1050	1180	1320	1440	1630
	175	130	0	0	0	0	0	0	0	0	360	440	540	660	780	970	1120	1260	1380	1600
	200	150	0	0	0	0	0	0	0	0	0	410	480	580	690	790	940	1050	1140	1320
460	40	30	0	0	300	480	750	1180	1470	1810	2230	2740	3370	4060	4930	5590	6370	—	—	—
	50	37	0	0	250	370	590	960	1200	1470	1810	2220	2710	3280	3970	4510	5130	5740	6270	7270
	60	45	0	0	0	320	500	810	1000	1240	1530	1870	2310	2770	3360	3810	4330	4860	5310	6150
	75	55	0	0	0	0	420	660	810	1020	1260	1540	1890	2280	2770	3150	3600	4050	4420	5160
	100	75	0	0	0	0	310	500	610	760	930	1140	1410	1690	2070	2340	2680	3010	3280	3820
	125	93	0	0	0	0	0	390	470	590	730	880	1110	1330	1500	1830	2080	2340	2550	2940
	150	110	0	0	0	0	0	0	420	510	630	770	950	1140	1380	1570	1790	2000	2180	2530
	175	130	0	0	0	0	0	0	0	450	550	680	830	1000	1220	1390	1580	1780	1950	2270
	200	150	0	0	0	0	0	0	0	0	480	590	730	880	1070	1210	1380	1550	1690	1970
575	40	30	0	300	480	750	1180	1860	2310	2850	3490	4290	5260	6340	7710	8740	—	—	—	—
	50	37	0	0	380	590	960	1500	1870	2310	2830	3460	4260	5130	6210	7050	8010	8980	9790	—
	60	45	0	0	330	500	790	1270	1590	1950	2400	2940	3600	4330	5250	5950	6780	7600	8290	9610
	75	55	0	0	0	420	660	1030	1290	1590	1960	2400	2950	3570	4330	4930	5620	6330	6910	8050
	100	75	0	0	0	0	490	780	960	1180	1450	1780	2190	2650	3220	3660	4180	4710	5140	5980
	125	93	0	0	0	0	0	600	740	920	1150	1420	1740	2100	2530	2880	3270	3660	3970	4600
	150	110	0	0	0	0	0	520	650	800	990	1210	1480	1780	2160	2450	2790	3120	3410	3950
	175	130	0	0	0	0	0	0	570	700	860	1060	1300	1570	1910	2170	2480	2780	3040	3540
	200	150	0	0	0	0	0	0	500	610	760	930	1140	1370	1670	1890	2160	2420	2640	3070

NOTE: If aluminum wire is used, it must be two sizes larger than copper wire and oxidation inhibitors must be used on connections.

NOTE: Shaded cells meet NEC ampacity requirements for only individual conductors in free air or water. Unshaded cells meet NEC ampacity requirements for either individual conductors or jacketed cable. See [“Cable Selection” on page 49.](#)

8-inch / Three-Phase / 3-Lead / Encapsulated Motor Fuse Sizing

Table 57.

Motor Model Prefix	Rating			Circuit Breakers or Fuse Amps (Maximum per NEC)			Circuit Breakers or Fuse Amps (Typical Submersible)		
	Standard	HP	KW	Volts	Standard Fuse	Dual Element Time Delay Fuse	Circuit Breaker	Standard Fuse	Dual Element Time Delay Fuse
239660	40	30	380	200	125	175	200	80	175
239600			460	175	100	150	175	70	150
239610			575	150	80	110	125	60	110
239661	50	37	380	250	150	200	225	100	200
239601			460	200	125	175	200	80	175
239611			575	175	90	150	150	70	150
239662	60	45	380	300	175	250	300	125	250
239602			460	250	150	200	225	100	200
239612			575	200	110	175	175	80	175
239663	75	55	380	350	200	300	350	150	300
239603			460	300	175	250	300	125	250
239613			575	250	150	200	225	100	200
239664	100	75	380	500	275	400	450	200	400
239604			460	400	225	350	400	175	350
239614			575	350	200	300	300	125	300
239165	125	93	380	700	400	600	600	250	600
239105			460	500	300	450	500	225	450
239115			575	450	250	350	400	175	350
239166	150	110	380	800	450	600	700	300	600
239106			460	600	350	500	600	250	500
239116			575	500	300	400	450	200	400
239167	175	130	380	800	500	700	800	350	700
239107			460	700	400	600	700	300	600
239117			575	600	350	450	600	225	450
239168	200	150	380	1000	600	800	1000	400	800
239108			460	800	450	700	800	350	700
239118			575	600	350	500	600	250	500

MOTOR, CABLE, & FUSE/CIRCUIT BREAKER REFERENCE
8-inch Motor, Cable, & Fuse/Circuit Breaker Reference

8-inch/Three-Phase/3-Lead/Encapsulated Hi-Temp (75 °C) Motor Fuse Sizing

Table 58.

Motor Model Prefix	Rating			Circuit Breakers or Fuse Amps (Maximum per NEC)			Circuit Breakers or Fuse Amps (Typical Submersible)		
	Standard	HP	KW	Volts	Standard Fuse	Dual Element Time Delay Fuse	Circuit Breaker	Standard Fuse	Dual Element Time Delay Fuse
279160	40	30	380	225	125	175	200	90	175
279100			460	175	110	150	175	70	150
279110			575	150	90	125	125	60	125
279161	50	37	380	250	150	225	225	110	225
279101			460	200	125	175	200	90	175
279111			575	175	100	150	150	70	150
279162	60	45	380	300	175	250	300	125	250
279102			460	275	150	225	250	100	225
279112			575	200	125	175	175	80	175
279163	75	56	380	400	200	350	350	150	350
279103			460	300	175	275	300	125	275
279113			575	275	150	225	225	100	225
279164	100	75	380	500	300	450	450	200	450
279104			460	400	250	350	400	175	350
279114			575	350	200	300	300	125	300
279165	125	93	380	700	400	600	600	250	600
279105			460	500	300	450	500	225	450
279115			575	450	250	350	400	175	350
279166	150	110	380	800	450	600	700	300	600
279106			460	600	350	500	600	250	500
279116			575	500	300	400	450	200	400

8-inch/Three-Phase/3-Lead/Rewindable MagForce Motor Specs/3600 RPM

Table 59.

Type	Motor Model Prefix	Rating				Maximum Load		Winding Resistance (Ohms)	Efficiency %
		HP	KW	Volts	SF	Amps	KW		
8-inch	263014	60	45	460	1.15	73	55.3	.13-.17	93
		75	55			91	68.9		
		100	75			124	92.3		
	263016	100	75			127	92.8	.09-.12	92
		125	93			160	117		
		125	93			150	114		
	263018	150	110			182	137	.07-.10	94
		175	130			216	161		

8-inch / Three-Phase / 3-Lead / Rewindable MagForce Motor 75 °C Cable

Table 60.

Motor Rating			Maximum Cable Length (ft) Measured from service entrance to motor																					
Volts	HP	KW	AWG Copper Wire Size									MCM Copper Wire Size												
			6	4	3	2	1	0	00	000	0000	250	300	350	400	500	600	700	750	800	900	1000	1250	1500
460	60	45	0	640	790	980	1200	1460	1790	2140	2570	2920	3310	3700	4020	4640	5110	5510	5690	5860	6160	6410	6950	7360
	75	55	0	510	630	780	960	1170	1430	1720	2060	2340	2650	2970	3220	3720	4100	4420	4570	4700	4940	5140	5570	5900
	100	75	0	0	0	560	690	840	1030	1230	1470	1680	1900	2120	2310	2660	2940	3170	3270	3360	3540	3680	3990	4230
	125	93	0	0	0	0	540	660	810	980	1170	1330	1510	1690	1830	2110	2330	2510	2600	2670	2810	2920	3170	3350
	150	110	0	0	0	0	0	580	710	860	1030	1170	1320	1480	1610	1860	2050	2210	2280	2350	2470	2570	2780	2950
	175	130	0	0	0	0	0	0	600	720	860	980	1120	1250	1350	1560	1720	1860	1920	1980	2080	2160	2340	2480
575	60	45	650	1000	1230	1530	1880	2290	2800	3350	4010	4570	5180	5780	6280	7250	7990	8610	8900	9150	9620	—	—	—
	75	55	0	800	990	1230	1500	1830	2240	2690	3220	3670	4150	4640	5040	5810	6410	6910	7140	7340	7720	8030	8710	9220
	100	75	0	580	710	880	1080	1310	1610	1930	2310	2620	2970	3320	3610	4160	4590	4950	5110	5260	5530	5750	6240	6610
	125	93	0	0	0	700	850	1040	1270	1530	1830	2080	2360	2640	2860	3300	3640	3930	4060	4170	4390	4560	4950	5240
	150	110	0	0	0	0	750	910	1120	1340	1610	1830	2070	2320	2520	2900	3200	3450	3570	3670	3860	4010	4350	4610
	175	130	0	0	0	0	0	770	940	1130	1350	1540	1750	1950	2120	2450	2700	2910	3000	3090	3250	3380	3670	3880

NOTE: If aluminum wire is used, it must be two sizes larger than copper wire and oxidation inhibitors must be used on connections.

NOTE: Shaded cells meet NEC ampacity requirements for only individual conductors in free air or water. Unshaded cells meet NEC ampacity requirements for either individual conductors or jacketed cable. See [“Cable Selection” on page 49.](#)

8-inch / Three-Phase / Encapsulated MagForce Motor Fuse Sizing

MagForce motors must be used with Variable Frequency Drives. Contact Franklin Electric for further details.

MOTOR, CABLE, & FUSE/CIRCUIT BREAKER REFERENCE
10-inch Motor, Cable, & Fuse/Circuit Breaker Reference

10-inch Motor, Cable, & Fuse/Circuit Breaker Reference

10-inch / Three-Phase / 3-Lead / Rewindable Motor Specs / 3510 RPM

Table 61.

Type	Motor Model Prefix	Rating				Full Load		Maximum Load		Winding Resistance (Ohms)	Efficiency %		Locked Rotor Amps	kVA Code
		HP	KW	Volts	SF	Amps	KW	Amps	KW		SF	FL		
10-inch	264134	175	130	460	1.15	219	149	254	172	.057-.070	87	87	1308	G
	264564			575		175		204		.090-.110			1046	
	264135	200	150	460		249	172	294	199	.049-.061			1557	G
	264565			575		199		236		.074-.090			1246	
	264136	250	185	460		322	213	377	246	.037-.046			2130	H
	264566			575		258		302		.055-.067			1704	

10-inch/Three-Phase/3-Lead/Rewindable MagForce Motor Specs/3600 RPM

Table 62.

Type	Motor Model Prefix	Rating				Maximum Load		Winding Resistance (Ohms)	Efficiency %
		HP	KW	Volts	SF	Amps	KW		SF
10-inch	264028	200	150	460	1.15	284	183	.027-.034	94
		250	185			354	229		
	264029	300	220			423	273		

10-inch / Three-Phase / 3-Lead / Rewindable Motor 75 °C Cable

Table 63.

Motor Rating			Maximum Cable Length (ft) Measured from service entrance to motor																				
Volts	HP	KW	AWG Copper Wire Size							MCM Copper Wire Size													
			2	1	0	00	000	0000	250	300	350	400	500	600	700	750	800	900	1000	1250	1500	1750	2000
460	175	130	0	0	0	570	690	830	950	1090	1220	1330	1550	1720	1860	1930	1990	2100	2190	2400	2550	2750	2860
	200	150	0	0	0	600	720	820	940	1050	1150	1340	1480	1610	1670	1720	1810	1890	2070	2210	2370	2470	
	250	185	0	0	0	0	0	640	730	810	880	1020	1130	1210	1260	1290	1360	1410	1540	1630	1740	1810	
575	175	130	0	0	730	900	1080	1310	1490	1700	1910	2080	2420	2690	2910	3020	3110	3280	3430	3750	3990	4300	5560
	200	150	0	0	780	940	1130	1290	1470	1650	1800	2090	2320	2520	2610	2690	2840	2960	3240	3450	3710	3860	
	250	185	0	0	0	730	880	1000	1140	1270	1380	1600	1760	1900	1960	2020	2120	2210	2400	2550	2730	2830	

NOTE: If aluminum wire is used, it must be two sizes larger than copper wire and oxidation inhibitors must be used on connections.

NOTE: Shaded cells meet NEC ampacity requirements for only individual conductors in free air or water. Unshaded cells meet NEC ampacity requirements for either individual conductors or jacketed cable. See [“Cable Selection” on page 49.](#)

10-inch / Three-Phase / 6-Lead / Rewindable Motor 75 °C Cable

Table 64.

Rating			Maximum Cable Length (ft) Measured from service entrance to motor																						
Volts	HP	KW	AWG Copper Wire Size									MCM Copper Wire Size													
			6	4	3	2	1	0	00	000	0000	250	300	350	400	500	600	700	750	800	900	1000	1250	1500	1750
460	175	130	0	0	0	460	570	700	850	1030	1240	1420	1630	1830	1990	2320	2580	2790	2890	2980	3150	3280	3600	3820	4120
	200	150	0	0	0	0	490	600	730	900	1080	1230	1410	1570	1720	2010	2220	2410	2500	2580	2710	2830	3100	3310	3550
	250	185	0	0	0	0	0	480	580	700	840	960	1090	1210	1320	1530	1690	1810	1890	1930	2040	2110	2310	2440	2610
575	175	130	0	480	580	720	900	1090	1350	1620	1960	2230	2550	2860	3120	3660	4030	4360	4530	4660	4920	5140	5620	5980	6450
	200	150	0	0	510	630	780	940	1170	1410	1690	1930	2200	2470	2700	3130	3480	3780	3910	4030	4260	4440	4860	5170	5560
	250	185	0	0	0	0	610	750	910	1090	1320	1500	1710	1900	2070	2400	2640	2850	2940	3030	3180	3310	3600	3820	4090

NOTE: If aluminum wire is used, it must be two sizes larger than copper wire and oxidation inhibitors must be used on connections.

NOTE: Shaded cells meet NEC ampacity requirements for only individual conductors in free air or water. Unshaded cells meet NEC ampacity requirements for either individual conductors or jacketed cable. See [“Cable Selection” on page 49.](#)

10-inch / Three-Phase / 3-Lead / Rewindable MagForce Motor 75 °C Cable

Table 65.

Motor Rating			Maximum Cable Length (ft) Measured from service entrance to motor																					
Volts	HP	KW	AWG Copper Wire Size								MCM Copper Wire Size													
			4	3	2	1	0	00	000	0000	250	300	350	400	500	600	700	750	800	900	1000	1250	1500	
460	200	150	0	0	0	0	0	0	0	550	660	750	850	950	1030	1190	1310	1410	1460	1500	1580	1640	1780	1890
	250	185	0	0	0	0	0	0	0	0	0	600	680	760	820	950	1050	1130	1170	1200	1270	1320	1430	1510
	300	220	0	0	0	0	0	0	0	0	0	0	570	630	690	800	880	950	980	1010	1060	1100	1190	1270

NOTE: If aluminum wire is used, it must be two sizes larger than copper wire and oxidation inhibitors must be used on connections.

NOTE: Shaded cells meet NEC ampacity requirements for only individual conductors in free air or water. Unshaded cells meet NEC ampacity requirements for either individual conductors or jacketed cable. See [“Cable Selection” on page 49.](#)

10-inch / Three-Phase / Rewindable MagForce Motor Fuse Sizing

MagForce motors must be used with Variable Frequency Drives. Contact Franklin Electric for further details.

MOTOR, CABLE, & FUSE/CIRCUIT BREAKER REFERENCE
12-inch Motor, Cable, & Fuse/Circuit Breaker Reference

12-inch Motor, Cable, & Fuse/Circuit Breaker Reference

12-inch/2-Pole/Three-Phase/3-Lead/Rewindable Motor Specs/3540 RPM

Table 66.

Type	Motor Model Prefix	Rating				Full Load		Maximum Load		Winding Resistance (Ohms)	Efficiency %		Locked Rotor Amps	kVA Code
		HP	KW	Volts	SF	Amps	KW	Amps	KW		SF	FL		
12-inch	265610	250	185	460	1.15	307	213	339	246	.032-.039	87	87	1797	G
	265690			575		246		272		.051-.062			1438	
	265611	300	220	460		362	251	425	289	.027-.033	88	88	2312	G
	265691			575		290		340		.040-.049			1850	
	265612	335	250	460		417	289	462	332	.027-.033	87	87	2513	G
	265692			575		334		370		.039-.047			2010	
	265614	400	300	460		493	342	533	394	.020-.025	88	88	3118	G
	265694			575		395		427		.030-.038			2494	
	265696	470	350	575		466	404	518	465	.030-.037	87	87	2655	G
	265697	540	400	575		521	451	596	519	.029-.036	90	89	2855	F

12-inch/4-Pole/Three-Phase/3-Lead/Rewindable Motor Specs/1760 RPM

Table 67.

Type	Motor Model Prefix	Rating				Full Load		Winding Resistance (Ohms)	Efficiency (%)	Locked Rotor Amps	kVA Code
		HP	KW	Volts	SF	Amps	KW				
12-inch	265682	175	130	460	1.0	238	149	.066-.081	87	1261	G
	265684	200	150			258	171	.063-.077		1367	F
	265686	250	185			312	213	.052-.064		1654	

12-inch/2-Pole/Three-Phase/6-Lead/Rewindable Motor Specs/3540 RPM

Table 68.

Type	Motor Model Prefix	Rating				Full Load		Maximum Load		Winding Resistance (Ohms)	Efficiency %		Locked Rotor Amps	kVA Code
		HP	KW	Volts	SF	Amps	KW	Amps	KW		SF	FL		
12-inch	265716	470	350	460	1.15	582	404	647	465	.020-.024	87	87	3319	G
	265717	540	400			651	451	745	519	.016-.020	90	89	3569	F

12-inch / Three-Phase / 3-Lead / Rewindable Motor 75 °C Cable

Table 69.

Motor Rating			Maximum Cable Length (ft) Measured from service entrance to motor																				
Volts	HP	KW	AWG Copper Wire Size							MCM Copper Wire Size													
			2	1	0	00	000	0000	250	300	350	400	500	600	700	750	800	900	1000	1250	1500	1750	2000
460	175	130	0	0	0	570	690	830	950	1090	1220	1330	1550	1720	1860	1930	1990	2100	2190	2400	2550	2750	2860
	200	150	0	0	0	0	600	720	820	940	1050	1150	1340	1480	1610	1670	1720	1810	1890	2070	2210	2370	2470
	250	185	0	0	0	0	0	0	640	730	810	880	1020	1130	1210	1260	1290	1360	1410	1540	1630	1740	1810
	300	220	0	0	0	0	0	0	0	650	720	790	920	1010	1100	1140	1170	1240	1290	1410	1500	1610	1670
575	175	130	0	0	730	900	1080	1310	1490	1700	1910	2080	2420	2690	2910	3020	3110	3280	3430	3750	3990	4300	5560
	200	150	0	0	0	780	940	1130	1290	1470	1650	1800	2090	2320	2520	2610	2690	2840	2960	3240	3450	3710	3860
	250	185	0	0	0	0	730	880	1000	1140	1270	1380	1600	1760	1900	1960	2020	2120	2210	2400	2550	2730	2830
	300	220	0	0	0	0	0	0	890	1010	1130	1240	1430	1590	1720	1780	1830	1930	2020	2200	2340	2510	2610

NOTE: If aluminum wire is used, it must be two sizes larger than copper wire and oxidation inhibitors must be used on connections.

NOTE: Shaded cells meet NEC ampacity requirements for only individual conductors in free air or water. Unshaded cells meet NEC ampacity requirements for either individual conductors or jacketed cable. See [“Cable Selection” on page 49.](#)

12-inch / Three-Phase / 6-Lead / Rewindable Motor 75°C Cable

Table 70.

Rating			Maximum Cable Length (ft) Measured from service entrance to motor																						
Volts	HP	KW	AWG Copper Wire Size								MCM Copper Wire Size														
			6	4	3	2	1	0	00	000	0000	250	300	350	400	500	600	700	750	800	900	1000	1250	1500	1750
460	175	130	0	0	0	460	570	700	850	1030	1240	1420	1630	1830	1990	2320	2580	2790	2890	2980	3150	3280	3600	3820	4120
	200	150	0	0	0	0	490	600	730	900	1080	1230	1410	1570	1720	2010	2220	2410	2500	2580	2710	2830	3100	3310	3550
	250	185	0	0	0	0	0	480	580	700	840	960	1090	1210	1320	1530	1690	1810	1890	1930	2040	2110	2310	2440	2610
	300	220	0	0	0	0	0	0	510	610	750	850	970	1080	1180	1380	1510	1650	1710	1750	1860	1930	2110	2250	2410
	335	250	0	0	0	0	0	0	0	570	690	780	880	990	1080	1240	1380	1480	1530	1570	1660	1720	1870	1990	2130
	400	300	0	0	0	0	0	0	0	0	600	670	780	870	960	1120	1240	1360	1410	1450	1540	1620	1780	1900	2050
	470	350	0	0	0	0	0	0	0	0	0	550	640	720	780	910	1020	1110	1140	1180	1240	1300	1440	1530	1650
	540	400	0	0	0	0	0	0	0	0	0	0	550	610	670	780	870	940	970	1000	1060	1110	1210	1300	1390
575	175	130	0	480	580	720	900	1090	1350	1620	1960	2230	2550	2860	3120	3660	4030	4360	4530	4660	4920	5140	5620	5980	6450
	200	150	0	0	510	630	780	940	1170	1410	1690	1930	2200	2470	2700	3130	3480	3780	3910	4030	4260	4440	4860	5170	5560
	250	185	0	0	0	0	610	750	910	1090	1320	1500	1710	1900	2070	2400	2640	2850	2940	3030	3180	3310	3600	3820	4090
	300	220	0	0	0	0	0	660	810	970	1170	1330	1510	1690	1860	2140	2380	2580	2670	2740	2890	3030	3300	3510	3760
	335	250	0	0	0	0	0	0	750	900	1080	1230	1390	1560	1690	1950	2160	2320	2400	2470	2590	2700	2940	3120	3340
	400	300	0	0	0	0	0	0	0	760	930	1060	1210	1380	1500	1750	1960	2130	2220	2280	2410	2530	2790	2980	3210
	470	350	0	0	0	0	0	0	0	0	760	870	1000	1120	1230	1440	1590	1720	1800	1860	1960	2050	2250	2400	2580
	540	400	0	0	0	0	0	0	0	0	0	760	870	970	1060	1230	1360	1480	1540	1590	1680	1750	1920	2040	2190

NOTE: If aluminum wire is used, it must be two sizes larger than copper wire and oxidation inhibitors must be used on connections.

NOTE: Shaded cells meet NEC ampacity requirements for only individual conductors in free air or water. Unshaded cells meet NEC ampacity requirements for either individual conductors or jacketed cable. See [“Cable Selection” on page 49.](#)

MOTOR, CABLE, & FUSE/CIRCUIT BREAKER REFERENCE
12-inch Motor, Cable, & Fuse/Circuit Breaker Reference

12-inch / Three-Phase / Rewindable Motor Fuse Sizing

MagForce motors must be used with Variable Frequency Drives. Contact Franklin Electric for further details.

MOTOR GLOSSARY

Term	Definition
A	Amp or amperage
AWG	American Wire Gauge
BJT	Bipolar Junction Transistor
°C	Degree Celsius
CB	Control Box
CRC	Capacitor Run Control
DI	Deionized
DOL	Direct on Line
Dv/dt	Rise Time of the Voltage
EFF	Efficiency
°F	Degree Fahrenheit
FDA	Food & Drug Administration
FL	Full Load Amps at Nameplate HP
ft	Foot
ft-lb	Foot Pound
ft/s	Feet per Second
GFCI	Ground Fault Circuit Interrupter
gpm	Gallons per Minute
HERO	High Efficiency Reverse Osmosis
hp	Horsepower
Hz	Hertz
ID	Inside Diameter
IGBT	Insulated Gate Bipolar Transistor
in	Inch
kVA	Kilovolt Amp
kVAR	Kilovolt Amp Rating
kW	Kilowatt (1000 watts)
L1, L2, L3	Line One, Line Two, Line Three
lb-ft	Pound Feet
L/min	Liters per Minute
lpm	
mA	Milliamp
max	Maximum
MCM	Thousand Circular Mils
mm	Millimeter
MOV	Metal Oxide Varister
NEC	National Electrical Code
NEMA	National Electrical Manufacturer Association
Nm	Newton Meter
NPSH	Net Positive Suction Head
OD	Outside Diameter
OL	Overload
PF	Power Factor
psi	Pounds per Square Inch
PSIG	Pounds per square inch gauge

MOTOR GLOSSARY

Term	Definition
PWM	Pulse Width Modulation
QD	Quick Disconnect
R	Resistance
RMA	Return Material Authorization
RMS	Root Mean Squared
rpm	Revolutions per Minute
SF	Service Factor = Amps at Maximum HP Loads
SFhp	Service Factor Horsepower
S/N	Serial Number
TDH	Total Dynamic Head
UNF	Unified Fine Thread
V	Voltage
VAC	Voltage Alternating Current
VDC	Voltage Direct Current
VFD	Variable Frequency Drive
W	Watts
XFMR	Transformer
Y-D	Wye-Delta
Ω	ohms

CONTROLS APPLICATION

Pumptec Family

Single-phase Pump Protection

Years of experience in designing and manufacturing our own motors mean that Franklin also knows how to protect them. Franklin's single-phase protective devices have been exclusively designed to help extend the life of Franklin motors. They monitor and diagnose motor load to prevent pump or motor failure due to adverse conditions, such as low-flow wells, pump damage, clogging, bound pump, or power mishaps.



SubMonitor Connect

Three-Phase Motor Protection, 50/60 Hz, 200–600 VAC, 1–700 HP

The Franklin Electric SubMonitor Connect, with its NEMA4x-rated display, offers a simple plug-and-play design to provide protection of three-phase motors against arc flash and a universal power outage. The SubMonitor Connect can also be connected to the FE Connect mobile App to provide real-time system monitoring.



SubDrive

Constant Pressure Variable Frequency Drives

From residential to agricultural and commercial applications, Franklin Electric's SubDrive family of variable frequency drives (VFDs) offers a cost-effective, easy-to-install upgrade to traditional systems. Simply wire up the unit, flip a switch or two, and you instantly have motor protection, pressure boosting and constant pressure delivery. The SubDrive family offers a range of motor voltage and horsepower ratings to meet a variety of submersible and above ground pumping system application needs.



Cerus X-Drive

Designed for variable torque applications up to 600 hp (480 V)*, the Cerus® X-Drive is Franklin Electric's all-inclusive drive solution for a variety of markets. Available as a standalone drive and in multiple enclosed configurations, these panels are built to last, with every detail and component centered around your requirements.

*Models are available for up to 700 hp for 575 V applications only.



Control and Protection Features

Table 71.

Specifications		Protection				Variable Frequency Drives (VFD)						
		QD Pumptec	Pumptec	Pumptec Plus	SubMonitor Connect	SubDrive Utility UT2W	SubDrive Utility UT3P	MonoDrive/ MonoDriveXT	SubDrive 75/100/150/300	SubDrive 20/30/50 Connect	SubDrive Connect Plus	Cerus X-Drive
Features	Constant Pressure					✓	✓	✓	✓	✓	✓	✓
	Electrical Filtering					Good	Good	Best	Best	Better	Better	dV/dt in 460V & 575V SUB models
Protection	Enclosure Rating		NEMA 3R	NEMA 3R	Base: NEMA 1 Display: NEMA 4X	NEMA 3R	NEMA 3R	NEMA 4	NEMA 4	NEMA 3R	NEMA 3R	NEMA 1 or 3R and UL Type 1, IP21, or 4X
	Underload	✓	✓	✓	✓	✓	✓	✓	✓	✓	✓	✓
	Under/Over Voltage	✓	✓	✓	✓	✓	✓	✓	✓	✓	✓	✓
	Rapid Cycle		✓	✓	✓		Soft Start	Soft Start	Soft Start	Soft Start	Soft Start	Soft Start
	Overload/Locked Pump	✓	✓	✓	✓	✓	✓	✓	✓	✓	✓	✓
	Open Circuit				Phase Loss	✓	✓	✓	✓	✓	✓	
	Short Circuit					✓	✓	✓	✓	✓	✓	✓
	Phase Imbalance				✓					✓	✓	✓
	Fireman's Override											✓
Input/Output/Control	Pressure Sensor (Hobbs)					✓	✓	✓	✓	✓	✓	✓
	Pressure Transducer					4-20mA	4-20mA			4-20mA	4-20mA	4-20mA or 0-10VDC
	Run Relay Output							Accessory	Accessory or Sub-Drive300	✓	✓	✓
	Fault Relay Output				✓					✓	✓	✓
	Broken Pipe					✓	✓			✓	✓	✓
	Pressure Sensor Error					✓	✓			✓	✓	✓
	Auxiliary Control				Hand/Off/Auto Modbus					✓	Run/Stop Hand/Auto	Programmable
	Wet Floor Sensor									✓	✓	
	Lead/Lag/Alternate				Accessory, 2 Drives	Accessory, 2 Drives	Accessory, 2 Drives	Accessory, 2 Drives	Accessory, 2 Drives	Built-in 2 Drives	Built-in up to 8 Drives	Built-in up to 8 Drives
	Communication				✓						Wired Terminal	3-wire terminals or RJ-45 sockets
Mobile App				✓					✓	✓	✓	

Checking Power for Controls

WARNING



High voltages capable of causing severe injury or death by electrical shock are present in this unit.

- Do not remove cover for wiring or periodic inspections while power is applied, or the unit is in operation.
- Capacitors inside the drive can still hold lethal voltage even after power has been disconnected. Allow 5 minutes for dangerous internal voltage to discharge before removing cover or working with internal components.

NOTICE

Risk of damage to equipment or other property.

- Before connecting power to a VFD, test incoming supply voltages to meet nameplate ratings.
- If any line-to-line voltage measures outside these ratings, do not use the drive on the incoming power supply. Add a suitably sized transformer to bring the voltages within these limits.
- If line to line voltage is imbalanced, or line to ground voltage is low on one phase, this may be an Open Delta Power Supply.
- If one or more line to ground voltage measures 0 V or less than noted above, check system fuses. If fuses are good, this may be a Corner-Grounded Delta Supply.

IMPORTANT: Do not use with a Ground Fault Circuit Interrupter (GFCI). If using an externally regulated generator, verify that the voltage and frequency are appropriate to supply the drive. FE drives have not been tested with inverter-controlled generators and AC-DC inverters.

NOTE:

- If a Corner-Grounded Delta Power Supply is used, special wiring may be required to prevent drive damage.
- If an Open Delta Power Supply is used, derate the drive to prevent drive damage and fault tripping. Refer to [“Power Connections and Transformers” on page 15](#). See product manual for derating requirements.

Table 72. Testing Incoming Supply Voltages for Nameplate Ratings

Model	Line-to-Line VAC	Line-to-Ground VAC
230 VAC	190 – 253 (208 – 230 +/- 10%)	Less than or equal to 253
460 VAC	414 – 506 (460 +/- 10%)	Less than or equal to 506

VFD Generator Sizing / SubDrive

Basic generator sizing for the Franklin Electric SubDrive Connect, SubDrive Utility UT2W, and SubDrive Utility UT3P is 1.5 times maximum input watts consumed by the drive, rounded up to the next normal sized generator.

For Franklin Electric X-Drive generator sizing, see [“VFD Generator Sizing / X-Drive” on page 90.](#)

Table 73.

Variable Frequency Drive (VFD)	Model	Recommended Minimum Generator Watts
SubDrive Utility	SubDrive Utility UT2W	6000
	SubDrive Utility UT3P	5000
SubDrive Connect	SubDrive15	3500
	SubDrive20	5700
	SubDrive30	7000
	SubDrive 50	11000
SubDrive Connect Plus	SDCP-SUB0723 ¹	8800
	SDCP-SUB1023 ¹	12000
	SDCP-SUB1523 ¹	17600
	SDCP-SUB0723	11200
	SDCP-SUB1023	14400
	SDCP-SUB1523	18400
	SDCP-SUB1043	17600
	SDCP-SUB1543	24000
	SDCP-SUB2043	26400
	SDCP-SUB2543	32000
SubDrive/MonoDrive NEMA 4	SDCP-SUB3043	38400
	MonoDrive 1/2 hp	2000
	MonoDrive 3/4 hp	3000
	MonoDrive 1 hp	3500
	MonoDriveXT 1.5 hp	4000
	MonoDriveXT 2 hp	5000
	SubDrive75	3500
	SubDrive100	5700
	SubDrive150	7000
SubDrive300	11000	

NOTE:

- ¹ Generator Sizing for 1-phase input.
- Generator sizes noted above are a minimum recommendation.

VFD Generator Sizing / X-Drive

Use this formula to find the minimum sized, three-phase generator for Franklin X-Drives:

Figure 30.

Watts = Maximum VFD Amp Rating x 1.5 x 1.732 x Motor Nameplate Voltage

Maximum VFD Amps = nameplate max of the VFD unit.
 (This value will typically be higher than the motor max amps)

1.5 (or 150%) = an industry value to provide tolerance for difference generator manufacturers and designs.

1.732 = square root of 3 (For 1-phase generators, delete this value).

Nameplate volts = voltage rating of the motor, not the power source (i.e. 460v, not 480v).

Cable Routing

Use the following diagram as a guide when routing wiring to VFD.

IMPORTANT: All control wiring—sensors, switches, transducers, etc.—should be in a separate conduit routed individually, not parallel, from high voltage wiring. In addition, any shielded cables should be properly grounded.

1. Mount the drive as close as possible to the service entrance panel. Wire directly to the service entrance. Do not connect to a sub-panel.
2. Use a dedicated branch circuit for the drive. Refer to the owner's manual for more details.
3. Route motor wiring out of building as soon as possible to reduce the chance of EMI or electrical interference on the motor cables. Separate input power and motor wiring by at least 8 inches (20.3 cm). Refer to the owner's manual for more details.
4. Cross over other branch circuits and facility wiring at a 90° angle. If it is necessary to run wiring in parallel, separate by at least 8 inches (20.3 cm).

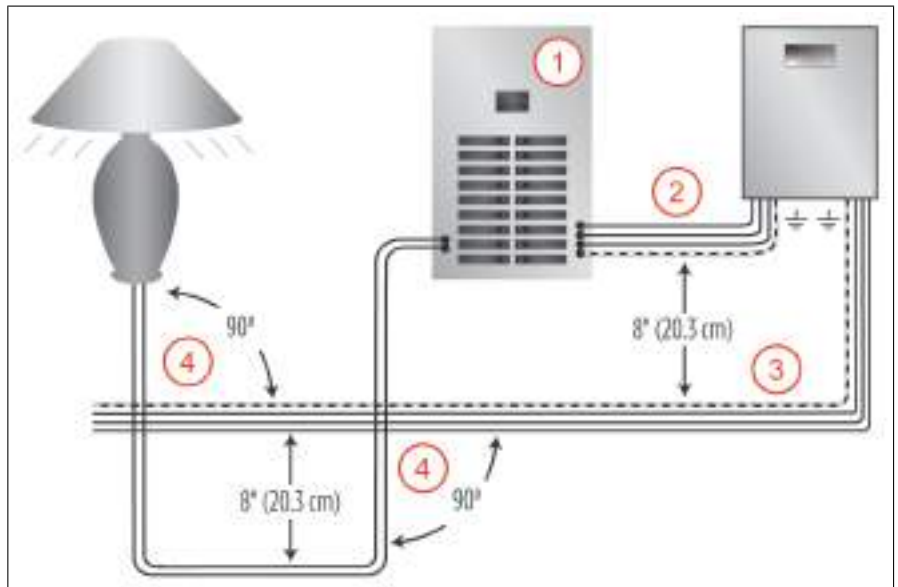

Fuse/Circuit Breaker and Wire Sizing

Use the following guidelines for [“Circuit Breaker Sizing & Max Input Cable Lengths / SubDrive”](#) on page 92 and [“Motor Cable Sizing”](#) on page 93:

- A 10-foot (3.05 m) section of cable is provided with the SubDrive to connect the pressure sensor.
- 1 ft = 0.305 m.
- Maximum allowable wire lengths are measured between the controller and motor.
- Do not use aluminum wires with SubDrive.
- All wiring must comply with the National Electrical Code and/or local codes.
- SubDrive minimum breaker amps may appear to exceed AIM manual specifications for the motors listed because SubDrive controllers are supplied from a single-phase service rather than three-phase Amps (SFA).
- Motor Overload Protection: The drive electronics provide motor overload protection by preventing motor current from exceeding the maximum Service Factor Amps (SFA). Motor over-temperature sensing is not provided by the drive.

CONTROLS APPLICATION
Fuse/Circuit Breaker and Wire Sizing

Circuit Breaker Sizing & Max Input Cable Lengths / SubDrive

Table 74.

SubDrive Family	Model	HP	Input Voltage	Input Phase	Fuse/Breaker Amps ²	AWG Copper Wire Sizes, 75 °C Insulation, and Panel to Drive Cable Lengths (in feet) ¹												
						14	12	10	8	6	4	3	2	1	1/0	2/0		
SubDrive Utility	UT2W	1/2	115	1	15	40	60	100	155	245	390	485	635	805	—	—		
		1/2				130	205	340	525	835	1315	1635	2150	2720	—	—		
	3/4	130	150			250	390	620	975	1210	1595	2020	—	—				
	1	70	110			185	285	450	715	885	1165	1475	—	—				
	1.5	—	—			140	215	340	540	670	880	1115	—	—				
	2	—	—			105	167	264	421	530	669	843	1062	—				
	UT3P	1/2	230		15	130	205	340	525	835	1315	1635	2150	2720	—	—		
		3/4				130	150	250	390	620	975	1210	1595	2020	—	—		
		1			70	110	185	285	450	715	885	1165	1475	—	—			
		1.5			—	—	140	215	340	540	670	880	1115	—	—			
		2			—	—	105	167	264	421	530	669	843	1062	—			
		2			—	—	105	167	264	421	530	669	843	1062	—			
SubDrive Connect	SubDrive 15	1.5	208	1	15	70	110	185	280	450	710	880	1160	1465	—	—		
		230	15		85	135	225	345	550	865	1075	1415	1795	—	—			
	SubDrive 20	2	208		20	—	—	115	180	285	450	555	730	925	—	—		
		230	20		—	85	140	220	345	550	680	895	1130	—	—			
	SubDrive 30	3	208		25	—	—	95	145	235	370	460	605	765	—	—		
		230	25		—	—	115	180	285	455	560	740	935	—	—			
	SubDrive 50	5	208		40	—	—	—	—	150	235	295	385	490	610	735		
		230	40		—	—	—	115	185	290	360	470	600	745	895			
SubDrive Connect Plus	SDCP-SUB0723	3	208 / 230	3	35	—	—	—	217	336	515	628	774	935	1128	1363		
		7.5			40	—	—	—	207	321	493	602	744	904	1094	1327		
	SDCP-SUB1023	5			1	50	—	—	—	—	232	356	433	534	646	779	941	
		10			3	50	—	—	—	—	244	376	459	567	688	833	1010	
	SDCP-SUB1523	7.5			1	70	—	—	—	—	—	245	298	368	445	536	648	
		15			3	60	—	—	—	—	—	293	357	441	536	649	787	
	SDCP-SUB1043	10			460	3	30	—	—	—	513	795	1225	1495	1847	2243	2715	3293
	SDCP-SUB1543	15					40	—	—	—	—	580	894	1091	1348	1637	1981	2403
	SDCP-SUB2043	20					45	—	—	—	—	524	806	985	1216	1477	1788	2169
	SDCP-SUB2543	25					60	—	—	—	—	—	661	807	997	1211	1466	1778
SDCP-SUB3043	30	70	—	—			—	—	—	—	551	637	831	1009	1222	1482		
		70	—	—			—	—	—	—	551	637	831	1009	1222	1482		

NOTE:

- ¹All values are based on a 3% voltage drop.
- Bold numbers are 194 °F (90 °C) insulation only. All other maximum cable length values are for 167 °F (75 °C) insulation.
- Blue shading indicates wire sizes that are larger than the maximum wire rating of the terminal blocks. An external junction box is required to splice the cables.
- ²All SDCP Models must be protected by fast-acting Class T fuses only, rated 100 A maximum.

Circuit Breaker Sizing & Max Input Cable Lengths / X-Drive

See appropriate owner's manual for proper sizing.

NOTE:

- The X-Drive is suitable for use on a circuit capable of delivering no more than 100,000 symmetrical amperes (rms) when protected by suitable Class J fuses.
- Integral solid-state circuit protection does not provide Branch Circuit Protection. Branch Circuit Protection must be provided in accordance with the National Electrical Code (NEC) and applicable state and local codes.

Motor Cable Sizing

- Use 75 °C copper wire in all SubDrive and X-Drive applications.
- For maximum motor cable lengths, refer to [“Motor, Cable, & Fuse/Circuit Breaker Reference” on page 49.](#)
- For best results, limit motor cable lengths to 1,000 feet. In applications with more than 1,000 feet:
 - For SubDrive Connect Plus models add an appropriately sized output filter.
 - Contact Franklin Electric Technical Support for guidance.
- Consult the appropriate SubDrive or X-Drive owner's manual for additional cable sizing information.

Pressure Tank

A SubDrive needs only a small pressure tank to maintain constant pressure. For pumps rated 12 gpm (45.4 lpm) or more, use a slightly larger tank for optimum pressure regulation. SubDrive can also use an existing tank with a much larger capacity. Refer to the owner's manual for tank vs. pump sizing.

NOTE: Franklin Electric 2-wire submersible motors require a minimum 20 gallon tank by volume.

Pressure Tank Pre-charge

Check tank pre-charge regularly to maintain optimum pressure regulation.

NOTE: 1 PSI = 0.068 bar

Table 75.

System Pressure (at Pressure Sensor)	Pressure Tank Setting (±2 PSI)
25	18
30	21
35	25
40	28
45	32
50 (Factory Set)	35
55	39
60	42
65	46
70	49
75	53
80	56

Minimum Supply Pipes

The minimum supply pipe diameter past the pressure sensor (transducer) should be selected not to exceed a maximum velocity of 8 feet per second (2.4 m/s) based on the flow rate of the system.

IMPORTANT: Water system piping should be verified by an experienced professional to ensure adequate flow.

Table 76.

Maximum GPM (lpm)	Minimum Pipe Diameter (inches)
11.0 (41.6)	0.75
19.6 (74.2)	1
30.6 (115.8)	1.25
44.1 (166.9)	1.5
78.3 (296.4)	2
122.4 (463)	2.5
176.3 (667)	3
240.0 (908)	3.5
313.3 (1186)	4
396.6 (1501)	4.5
489.6 (1853)	5

CONTROLS MAINTENANCE

Pumptec-Plus: Troubleshooting During Installation

Table 77.

Symptom	Possible Cause	Solution
Unit seems dead (No Lights)	No power to unit	Check wiring. Power supply voltage should be applied to L1 and L2 terminals of the Pumptec-Plus. In some installations, the pressure switch or other control device is wired to the input of the Pumptec-Plus. Make sure this switch is closed.
Flashing Yellow Light	Unit needs to be calibrated	Pumptec-Plus requires calibration before use. Otherwise, the Pumptec-Plus will overload on most pump systems at initial installation. See the Pumptec-Plus manual for further instruction.
	Miscalibrated	Pumptec-Plus should be calibrated on a full recovery well with the maximum water flow. NOTE: Flow restrictions are not recommended.
Flashing Yellow Light During Calibration	2-wire motor	Usually during calibration, a flashing green light condition will occur 2 to 3 seconds after taking the snapshot of the motor load. On some two-wire motors, the yellow light will flash instead of the green light. Press and release the reset button. The green should start flashing.
Flashing Red and Yellow Lights	Power interruption	During the installation of Pumptec-Plus, power may be switched on and off several times. If power is cycled more than four times within a minute, Pumptec-Plus will trip on rapid cycle. Press and release the reset button to restart the unit.
	Float switch	A bobbing float switch may cause the unit to detect a rapid cycle condition on any motor or an overload condition on two-wire motors. Try to reduce water splashing or use a different switch.
Flashing Red Light	High line voltage	The line voltage is over 253 volts. Check line voltage. Report high line voltage to the power company.
	Unloaded generator	If you using a generator, the line voltage may become too high when the generator unloads. Pumptec-Plus will not allow the motor to turn on again until the line voltage returns to normal. Overvoltage trips will also occur if the frequency drops too far below 60 Hz.
Solid Red Light	Low line voltage	The line voltage is below 207 volts. Check line voltage.
	Loose connections	Check for loose connections which may cause voltage drops.
	Loaded generator	If you are using a generator, the line voltage may become too low when the generator loads. Pumptec-Plus will trip on undervoltage if the generator voltage drops below 207 volts for more than 2,5 seconds. Undervoltage trips will also occur if the line frequency rises too far above 60 Hz.

NOTE: Standard kVA ratings are shown. If the power company allows transformer loading higher than standard, higher loading values may be used to meet total effective kVA required, as long as correct voltage and balance are maintained.

CONTROLS MAINTENANCE**Pumptec-Plus and Pumptec with 3 Lights: Troubleshooting After Installation****Pumptec-Plus and Pumptec with 3 Lights: Troubleshooting After Installation****Table 78.**

Symptom	Possible Cause	Solution
Solid Yellow Light	Dry Well	Wait for the automatic restart timer to time out. During the time out period, the well should recover and fill with water. If the automatic reset timer of the Pumptec-Plus is set to the manual position, push the reset button to reactivate the unit. If the reset timer is set to manual in the Pumptec, turn off power for 5 seconds to reset the unit.
	Blocked Intake	Clear or replace pump intake screen.
	Blocked Discharge	Remove blockage in plumbing.
	Check Valve Stuck	Replace check valve.
	Broken Shaft	Replace broken parts.
	Severe Rapid Cycling	Machine-gun rapid cycling can cause an overload condition. See flashing red and yellow lights section below.
	Worn Pump	Replace worn pump parts and recalibrate.
Flashing Yellow Light	Stalled Motor	Repair or replace motor. Pump may be sand- or mud-blocked.
	Float Switch	A bobbing float switch can cause two-wire motors to stall. Arrange plumbing to avoid splashing water. Replace float switch.
	Ground Fault	Check insulation resistance on motor and control box cable.
Solid Red Light	Low Line Voltage	The line voltage is below 207 volts. Pumptec and Pumptec-Plus will try to restart the motor approximately every two minutes until the line voltage is normal.
	Loose Connections	Check for excessive voltage drops in the system electrical connections (i.e. circuit breakers, fuse clips, pressure switch, and Pumptec-Plus L1 and L2 terminals). Repair connections.
Flashing Red Light	High Line Voltage	The line voltage is over 253 volts. Check line voltage. Report high line voltage to the power company.
Flashing Red and Yellow Lights	Rapid Cycle	The most common cause for the rapid cycle condition is a waterlogged tank. Check for a ruptured bladder in the water tank. Check the air volume control or snifter valve for proper operation. Check setting on the pressure switch and examine for defects.
	Leaky Well System	Replace damaged pipes or repair leaks.
	Stuck Check Valve	Failed valve will not hold pressure. Replace valve.
	Float Switch	A bobbing float switch may cause the unit to detect a rapid cycle condition on any motor or an overload condition on 2-wire motors. To reset a Pumptec, remove power for 5 seconds. To reset a Pumptec-Plus, press and release the reset button. To eliminate float switch bounce, try to reduce water splash or use a different switch.

SubMonitor Connect: Fault and Alarm Descriptions

Table 79.

Fault	Type	Displayed Text	Description	Default Setting
Overload	Fault	OVERLOAD FAULT	Selectable Class 5-30, and S. Trips if the current integrator exceeds the trip point.	Class 5
Over Current	Fault	OVERCURR FAULT	Trips if the measured current is greater than the trip point setting for a time that exceeds the over current trip time setting.	On, 110%, 30 s
Over Power	Fault or Alarm	OVERPOWER FAULT	Trips if the measured kW is greater than the kW trip point setting continuously for a time that exceeds the over power trip time setting.	On, 125%, 10 s
Under Power	Fault or Alarm	UNDER-POWER FAULT	Trips if the measured kW is less than the kW trip point setting continuously for a time that exceeds the under power trip time setting.	On, 65%, 1 s
Insulation Check	Fault and Alarm	INSULATION FAULT	Trips if the measured resistance of the motor windings is less than insulation check resistance fault/alarm trip threshold.	Off, 500 kΩ (Alarm), 200 kΩ (Fault)
Over Voltage	Fault or Alarm	OVERVOLT FAULT	Trips if the average of the 3 line-to-line voltages exceeds the nominal voltage setting by the over voltage percentage setting continuously for a time exceeding the over voltage trip time setting.	On, 110%, 10 s
Under Voltage	Fault or Alarm	UNDERVOLT FAULT	Trips if the average of the 3 line-to-line voltages is lower than the nominal voltage setting by the under voltage percentage continuously for a time exceeding the under voltage trip time setting.	On, 90%, 10 s
Current Phase Unbalanced	Fault or Alarm	CURR UNBL FAULT	Trips if any of the 3 measured phase currents deviates from the average current by a value greater than or equal to the trip percentage setting.	On, 5%, 10 s
Voltage Phase Loss	Fault	VOLT LOSS FAULT	Trips if the L-G voltage of any phase is more than 40% lower than the average voltage.	On, 60 VAC, N/A
Voltage Phase Unbalanced	Fault or Alarm	VOLT UNBL FAULT	Trips if any of the 3 measured line-to-line voltages deviates from the average line-to-line voltage by a value greater than or equal to the voltage phase unbalance trip percentage setting for a time exceeding the voltage phase unbalanced trip time setting.	Off, 1%, 10 s
Cycle Fault	Fault	CYCLE FAULT	Trips if run command is triggered at a rate exceeding the start limit divided by the limit period.	Off
Locked Rotor	Fault	LCKD ROTOR FAULT	Trips if the current exceeds 300% of the calculated FLA setting for 0.5 seconds, the current is flat or increasing and the power factor is not changing. This protection is active during the first ten seconds of operation after a start.	On
Stall	Fault	STALL FAULT	Trips if the current exceeds 300% of the FLA for 0.5 seconds, the current is flat or increasing and the power factor is not changing. This protection is active after the first ten seconds of a start event and after the FLA has been determined.	Off
Max Time to Start	Fault	START TIME FAULT	Trips ten seconds after current is detected following a contactor closure, if the average current is above 200% of the FLA setting and still declining.	Off
Out of Calibration	Fault	OUT OF CAL FAULT	Trips if the measured peak inrush is outside the range of 400% to 1400% of the FLA/SFA setting. This protection is only active during each start sequence and for 10 seconds after every start.	Off
PT100/PT1000 Over Temp	Fault	RTD TEMP FAULT	Trips if the temperature measured by a PT100 or PT1000 exceeds the trip temperature setting.	Off

CONTROLS MAINTENANCE

SubDrive/MonoDrive NEMA 1 and NEMA 4 Troubleshooting

Table 79 (continued)

Fault	Type	Displayed Text	Description	Default Setting
Reverse Phase	Fault	PHASE ORDR FAULT	Trips if the phase order detected is different than phase order setting of either A-B-C or A-C-B.	On
No Current	Fault or Alarm	NO CURR FAULT	Faults if there is no current for three seconds after a start.	Off
Unexpected Current Flow	Alarm	UNEXP CURR FAULT	Alarms if the starter detects current flow above a threshold of 0.2 A while the starter is in the stopped state.	Off
Ground Fault	Fault	GROUND FAULT	Trips if the vector sum of the 3 measured phase currents exceeds the ground fault threshold setting.	On, 1 A

SubDrive/MonoDrive NEMA 1 and NEMA 4 Troubleshooting

Diagnostic Fault Codes

Table 80.

Number of Flashes	Fault	Possible Cause	Corrective Action
1	Motor Underload	<ul style="list-style-type: none"> High static, light loading pump Over-pumped well Broken shaft or coupling Blocked screen, worn pump Air/gas locked pump Incorrect motor/pump HP setting Incorrect Underload Sensitivity setting Frequency near maximum with load less than configured underload sensitivity (Potentiometer) System is drawing down to pump inlet (out of water) SubDrive only: pump rotation incorrect. 	<ul style="list-style-type: none"> Reset Potentiometer for less sensitivity if not out of water. If possible, set deeper in well to reduce possibility of air/gas locked pump. Verify DIP switches are set properly. SubDrive only: correct pump rotation.
2	Undervoltage	<ul style="list-style-type: none"> Low line voltage High input voltage Mis-wired input leads Loose connection at breaker or panel Incorrect motor voltage setting NEMA 4 Models: Malfunctioning fan 	<ul style="list-style-type: none"> Check incoming line voltage, including circuit breaker or fuses, and contact the power company if needed. <ul style="list-style-type: none"> For 150 VAC, line should be 190-260 VAC. Check incoming power connections and correct or tighten if necessary. For malfunctioning fan: <ul style="list-style-type: none"> Remove power from the drive. Wait five minutes. Remove Customer Access panel and unplug the fan connector from the control board. Reinstall customer access panel. Reapply power to the drive. If the drive operates normally, replace the fan.
3	Locked Pump	<ul style="list-style-type: none"> Motor and/or pump misalignment Dragging motor and/or pump Abrasives in pump Amperage above SFA 	<ul style="list-style-type: none"> Verify correct motor/pump HP setting. Remove and repair or replace as required.

Table 80 (continued)

Number of Flashes	Fault	Possible Cause	Corrective Action
4 (MonoDrive Only)	Incorrectly Wired	<ul style="list-style-type: none"> • Loose connection • Defective motor or drop cable • Incorrect motor • Open circuit reading on DC test at startup 	<ul style="list-style-type: none"> • Check motor terminal connections. Tighten and repair as necessary. • Disconnect motor leads. Check drop cable and motor resistance. • Check drive with a “dry” bench top motor. If drive will not run the motor or achieve under-load fault at max frequency, replace the drive.
5	Open Circuit	<ul style="list-style-type: none"> • Loose connection • Defective motor or drop cable • Incorrect motor • Open circuit reading on DC test at startup 	<ul style="list-style-type: none"> • Check motor terminal connections. Tighten and repair as necessary. • Disconnect motor leads. Check drop cable and motor resistance. • Check drive with a “dry” bench top motor. If drive will not run the motor or achieve under-load fault at max frequency, replace the drive.
6	Short Circuit/ Over-current	<ul style="list-style-type: none"> • If fault occurs immediately after power-up: <ul style="list-style-type: none"> – Shorted connection – Defective cable – Bad splice or failed motor • If fault occurs while motor running: <ul style="list-style-type: none"> – Over-current due to trapped debris in pump – Incorrect HP setting • Amperage exceeded 50 amps on DC test or while running • Incorrect wiring • Phase to phase short circuit • Phase to ground short circuit 	<ul style="list-style-type: none"> • Verify wire connections at motor terminal block. • Disconnect motor leads and use megger to check motor insulation resistance. If low reading, replace motor. • If fault is still present after resetting the drive and removing motor leads, replace drive.
7	Overheated Drive	<ul style="list-style-type: none"> • High ambient temperature • High internal drive temperature • Direct sunlight • Obstruction of airflow 	<ul style="list-style-type: none"> • Check air screen for debris. Clean as necessary. • Check for proper fan operation. Replace as necessary. • Ensure internal drive temperature is below 80 °C (179 °F) before starting the motor, or below 70 °C before starting a motor after a Locked Pump fault. • Refer to drive placement recommendations.
8 (SubDrive 300 Only)	Overpressure	<ul style="list-style-type: none"> • Improper pre-charge • Valve closing too fast • Pressure setting too close to relief valve rating 	<ul style="list-style-type: none"> • Reset the pre-charge to 70% of the sensor rating. • Reduce the pressure setting well below relief valve rating. • Use larger pressure tank. • Verify valve operation is within manufacturer’s specifications. • Reduce system pressure setting to a value less than the pressure relief rating.
Rapid	Internal Fault	<ul style="list-style-type: none"> • A fault was detected internal to the drive 	<ul style="list-style-type: none"> • Contact Franklin Electric Technical Support. • Unit may require replacement. Contact supplier.

CONTROLS MAINTENANCE

SubDrive/MonoDrive NEMA 1 and NEMA 4 Troubleshooting

Symptom Based Troubleshooting

Table 81.

Condition	Display	Possible Cause	Corrective Action
No water	None	<ul style="list-style-type: none"> No supply voltage present 	<ul style="list-style-type: none"> Connect supply voltage. If correct voltage is present, replace drive.
	Solid Green	<ul style="list-style-type: none"> Pressure sensor circuit 	<ul style="list-style-type: none"> Verify water pressure is below system set point.
	Solid Red or Sold Red and Green	<ul style="list-style-type: none"> Power surge Bad component Internal Fault 	<ul style="list-style-type: none"> Turn off power to clear the fault and verify input voltage. If repetitive, replace drive.
	Flashing Red	<ul style="list-style-type: none"> Fault detected 	<ul style="list-style-type: none"> Refer to “Diagnostic Fault Codes” on page 98.
	Flashing Green	<ul style="list-style-type: none"> Loose switch or cable connection Gulping water at pump inlet 	<ul style="list-style-type: none"> If frequency max with low amps, check for closed valve or stuck check valve. If frequency max with high amps, check for hole in pipe. If frequency max with erratic amps, check pump operation and dragging impellers. This is not a drive problem. Check all connections, disconnect power, allow well to recover, and retry.
Pressure Fluctuations (Poor Regulation)	Flashing Green	<ul style="list-style-type: none"> Pressure sensor placement and setting Pressure gauge placement Pressure tank size and pre-charge Leak in system Air in pump intake (lack of submergence) 	<ul style="list-style-type: none"> Correct pressure sensor placement and settings. Tank may be too small for system flow. This is not a drive problem. Disconnect power and check pressure gauge for drop. Set deeper in the well or tank; install a flow sleeve with airtight seal around drop pipe and cable. If fluctuation is only on branches before sensor, flip DIP SW 4 to “on” (07C and newer).
Run On (pump won't stop)	Flashing Green	<ul style="list-style-type: none"> Pressure sensor placement and setting Tank pre-charge pressure Impeller damage Leaky system Sized improperly (pump can't build enough head) 	<ul style="list-style-type: none"> Check frequency at low flows, pressure setting may be too close to pump max head. Verify precharge at 70% if tank size is larger than minimum, increase precharge (up to 85%). Verify that the system will build and hold pressure.
Runs But Trips	Flashing Red	<ul style="list-style-type: none"> Check fault code and see corrective action 	<ul style="list-style-type: none"> Refer to “Diagnostic Fault Codes” on page 98.
Low Pressure	Flashing Green	<ul style="list-style-type: none"> Pressure sensor setting, pump sizing 	<ul style="list-style-type: none"> Adjust pressure sensor. Check pump rotation. Check frequency at max flow and max pressure.
High Pressure	Flashing Green	<ul style="list-style-type: none"> Pressure sensor setting Shorted sensor wire 	<ul style="list-style-type: none"> Adjust pressure sensor. Remove sensor wire at Input Board. <ul style="list-style-type: none"> If drive stops running, wire may be shorted. If drive continues to run, replace drive. Verify condition of sensor wire. Repair or replace if necessary.
Audible Noises	Flashing Green	<ul style="list-style-type: none"> Fan Drive Hydraulic Plumbing 	<ul style="list-style-type: none"> For excessive fan noise, replace fan. If fan noise is normal, drive will need to be relocated to a more remote area. If hydraulic, try raising or lowering depth of pump. Pressure tank location should be at entrance of water line into house.





Table 81 (continued)

Condition	Display	Possible Cause	Corrective Action
No Lights	None	<ul style="list-style-type: none"> Ribbon cable detached from LED printed circuit board 	<ul style="list-style-type: none"> Reattach cable. If cable is attached, replace drive.
RFI-EMI Interference	Flashing Green	<ul style="list-style-type: none"> Poor grounding Wire routing Radio or other electronic equipment too close to motor leads 	<ul style="list-style-type: none"> Adhere to grounding and wire routing recommendations. An additional external filter may be needed.

SubDrive Utility UT2W Maintenance

Diagnostic Fault Codes

Table 82.

Flashes	Fault	Possible Cause	Corrective Action
	Motor Underload	<ul style="list-style-type: none"> High static, light loading pump Over-pumped well Broken shaft or coupling Blocked screen, worn pump Air/gas locked pump Incorrect motor/pump HP setting Incorrect Underload Sensitivity setting Frequency near maximum with load less than configured underload sensitivity (Potentiometer) System is drawing down to pump inlet (out of water) 	<ul style="list-style-type: none"> Reset Potentiometer for less sensitivity if not out of water. If possible, set deeper in well to reduce possibility of air/gas locked pump. Verify DIP switches are set properly.
	Undervoltage / Overvoltage	<ul style="list-style-type: none"> Low line voltage High input voltage Mis-wired input leads Loose connection at breaker or panel Incorrect motor voltage setting 	<ul style="list-style-type: none"> Check incoming line voltage, including circuit breaker or fuses, and contact the power company if needed. <ul style="list-style-type: none"> For 115 VAC, line should be 105-130 VAC. For 230 VAC, line should be 190-260 VAC. Check incoming power connections and correct or tighten if necessary.
	Locked Pump	<ul style="list-style-type: none"> Motor and/or pump misalignment Dragging motor and/or pump Abrasives in pump Amperage above SFA 	<ul style="list-style-type: none"> Verify correct motor/pump HP setting. Remove and repair or replace as required.
	Open circuit / Open Phase	<ul style="list-style-type: none"> Loose connection Defective motor or drop cable Incorrect motor Open circuit reading on DC test at startup 	<ul style="list-style-type: none"> Check motor terminal connections. Tighten and repair as necessary. Disconnect motor leads. Check drop cable and motor resistance. Check drive with a “dry” bench top motor. If drive will not run the motor or achieve underload fault at max frequency, replace the drive.



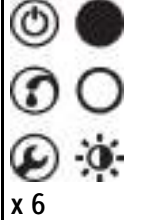
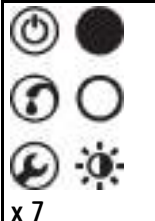
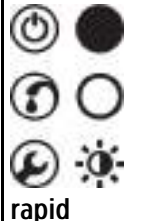
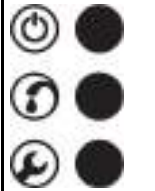
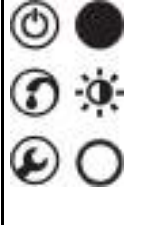
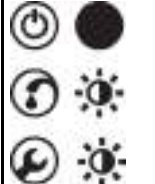

CONTROLS MAINTENANCE
SubDrive Utility UT2W Maintenance

Table 82 (continued)

Flashes	Fault	Possible Cause	Corrective Action
 x 6	Short Circuit Over-Current	<ul style="list-style-type: none"> If fault occurs immediately after power-up: <ul style="list-style-type: none"> Shorted connection Defective cable Bad splice or failed motor If fault occurs while motor running: <ul style="list-style-type: none"> Over-current due to trapped debris in pump Incorrect HP setting Amperage exceeded 72 amps on DC test or while running Incorrect wiring Phase to phase short circuit Phase to ground short circuit 	<ul style="list-style-type: none"> Verify wire connections at motor terminal block. Disconnect motor leads and use megger to check motor insulation resistance. If low reading, replace motor. If fault is still present after resetting the drive and removing motor leads, replace drive.
 x 7	Overheated Drive	<ul style="list-style-type: none"> High ambient temperature High internal drive temperature Direct sunlight Obstruction of airflow 	<ul style="list-style-type: none"> Check air screen for debris. Clean as necessary. Check for proper fan operation. Replace as necessary. Internal drive temperature must be below 80 °C before starting the motor, or below 70 °C before starting a motor after a Locked Pump fault. Refer to drive placement recommendations.
 rapid	Internal Fault	<ul style="list-style-type: none"> A fault was detected internal to the drive 	<ul style="list-style-type: none"> Contact Franklin Electric Technical Support. Unit may require replacement. Contact supplier.
	Invalid Configuration	<ul style="list-style-type: none"> DIP switches are incorrectly set 	<ul style="list-style-type: none"> Verify DIP switch settings.
	Broken Pipe	<ul style="list-style-type: none"> Drive runs at full power for 10 minutes without reaching pressure setpoint Broken pipe or large leak is detected in the system Large water draw, such as a sprinkler system or filling a pool, does not allow system to reach pressure setpoint 	<ul style="list-style-type: none"> Check system for large leak or broken pipe. If the system contains a sprinkler system or is being used to fill a pool or cistern, disable the Broken Pipe Detection.
	Transducer Fault	<ul style="list-style-type: none"> DIP SW2 position 1 is incorrectly set Pressure transducer is incorrectly wired, disconnected, damaged, or failed Pressure transducer signal is outside the expected range 	<ul style="list-style-type: none"> Verify DIP SW2 position 1 is in the XDCR (up) position if using a transducer. Inspect transducer wiring connections. Replace transducer.

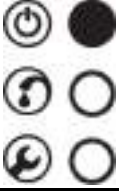
Symptom Based Troubleshooting

Table 83.



Condition	Display	Possible Cause	Corrective Action
No water		<ul style="list-style-type: none"> No supply voltage present 	<ul style="list-style-type: none"> Connect supply voltage. If correct voltage is present, replace drive.
		<ul style="list-style-type: none"> Pressure sensor circuit 	<ul style="list-style-type: none"> Verify water pressure is below system set point.
		<ul style="list-style-type: none"> Fault detected Underload 	<ul style="list-style-type: none"> Refer to “Diagnostic Fault Codes” on page 101. Repair or replace the required foot valve for pump applications with suction lift.
		<ul style="list-style-type: none"> Power surge Bad component Internal Fault 	<ul style="list-style-type: none"> Turn off power to clear the fault and verify input voltage. If repetitive, replace drive.
		<ul style="list-style-type: none"> Loose switch or cable connection Gulping water at pump inlet 	<ul style="list-style-type: none"> If frequency max with low amps, check for closed valve or stuck check valve. If frequency max with high amps, check for hole in pipe. If frequency max with erratic amps, check pump operation, dragging impellers. This is not a drive problem. Check all connections, disconnect power, allow well to recover, and retry. Confirm max amps setting is set correctly. Confirm Underload Sensitivity is set correctly.
		<ul style="list-style-type: none"> Invalid Configuration 	<ul style="list-style-type: none"> A max amps setting is not configured for PSC or CEN applications.

CONTROLS MAINTENANCE
SubDrive Utility UT2W Maintenance

Table 83 (continued)

Condition	Display	Possible Cause	Corrective Action
Pressure Fluctuations (Poor Regulation)		<ul style="list-style-type: none"> Pressure sensor placement and setting Pressure gauge placement Pressure tank size and pre-charge Leak in system Air in pump intake (lack of submergence) System response setting 	<ul style="list-style-type: none"> Correct pressure sensor placement and settings. Tank may be too small for system flow. This is not a drive problem. Disconnect power and check pressure gauge for drop. Set deeper in the well or tank; install a flow sleeve with airtight seal around drop pipe and cable. If fluctuation is only on branches before sensor, enable Steady Flow. Adjust System Response value.
Run On (pump won't stop)		<ul style="list-style-type: none"> Pressure sensor placement and setting Tank pre-charge pressure Impeller damage Leaky system Sized improperly (pump can't build enough head) 	<ul style="list-style-type: none"> Check frequency at low flows, pressure setting may be too close to pump max head. Verify precharge at 70% if tank size is larger than minimum, increase precharge (up to 85%). Verify that the system will build and hold pressure. Enable bump and/or aggressive bump. Increase minimum frequency.
Runs But Trips		<ul style="list-style-type: none"> Check fault code and see corrective action 	<ul style="list-style-type: none"> Proceed to fault code description and remedy.
Low Pressure		<ul style="list-style-type: none"> Pressure sensor setting, pump sizing High temperature 	<ul style="list-style-type: none"> Adjust pressure sensor. Check pump rotation. Check frequency at max flow and max pressure. High ambient and/or drive temperature will cause drive to fold-back power and run with reduced performance.
High Pressure		<ul style="list-style-type: none"> Pressure sensor setting Shorted sensor wire 	<ul style="list-style-type: none"> Adjust pressure sensor. Remove sensor wire at Input Board. <ul style="list-style-type: none"> If drive stops running, wire may be shorted. If drive continues to run, replace drive. Verify condition of sensor wire. Repair or replace if necessary.
Audible Noises		<ul style="list-style-type: none"> Fan Drive Hydraulic Plumbing 	<ul style="list-style-type: none"> For excessive fan noise, replace fan. If fan noise is normal, drive will need to be relocated to a more remote area. If hydraulic, try raising or lowering depth of pump. Pressure tank location should be at entrance of water line into house.

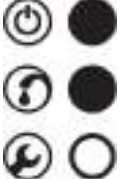
Table 83 (continued)

Condition	Display	Possible Cause	Corrective Action
RFI-EMI Interference		<ul style="list-style-type: none"> • Poor grounding • Wire routing • Radio or other electronic equipment too close to motor leads 	<ul style="list-style-type: none"> • Adhere to grounding and wire routing recommendations. • An additional external filter may be needed.
Intermittent drive or pump operation	 x 5	<ul style="list-style-type: none"> • Open Circuit • Drive motor output is wired through the pump pressure switch 	<ul style="list-style-type: none"> • Wire the drive directly to the pump/motor, bypassing the pump pressure switch.

SubDrive Utility UT3P Maintenance

Diagnostic Fault Codes

Table 84.



















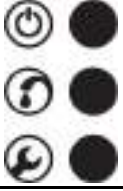





















Flashes	Fault	Possible Cause	Corrective Action
	Motor Underload	<ul style="list-style-type: none"> High static, light loading pump Air/gas locked pump Over-pumped well Broken shaft or coupling Blocked screen, worn pump Air/gas locked pump Incorrect motor/pump HP setting Incorrect Underload Sensitivity setting Frequency near maximum with load less than configured underload sensitivity (Potentiometer) System is drawing down to pump inlet (out of water) 	<ul style="list-style-type: none"> Reset Potentiometer for less sensitivity if not out of water. If possible, set deeper in well. Verify DIP switches are set properly. Check pump rotation. Reconnect for proper rotation if necessary.
	Undervoltage / Overvoltage	<ul style="list-style-type: none"> Low line voltage High input voltage Mis-wired input leads Loose connection at breaker or panel Incorrect motor voltage setting 	<ul style="list-style-type: none"> Check incoming line voltage, including circuit breaker or fuses, and contact the power company if needed. <ul style="list-style-type: none"> For 230 VAC, line should be 190-260 VAC. Check incoming power connections and correct or tighten if necessary.
	Locked Pump	<ul style="list-style-type: none"> Motor and/or pump misalignment Dragging motor and/or pump Abrasives in pump Amperage above SFA 	<ul style="list-style-type: none"> Verify correct motor/pump HP setting. Remove and repair or replace as required.
	Incorrectly Wired	<ul style="list-style-type: none"> Wrong resistance values on main and start 	<ul style="list-style-type: none"> Wrong resistance on DC test at start. Check wiring, motor size, and DIP switch setting. Adjust or repair as needed.
	Open circuit / Open Phase Phase Imbalance (3-phase only)	<ul style="list-style-type: none"> Loose connection Defective motor or drop cable Incorrect motor Open circuit reading on DC test at startup Loose connection Defective motor or drop cable Incorrect motor 	<ul style="list-style-type: none"> Check motor terminal connections. Tighten and repair as necessary. Disconnect motor leads. Check drop cable and motor resistance. Check drive with a “dry” bench top motor. If drive will not run the motor or achieve underload fault at max frequency, replace the drive.

Table 84 (continued)







Flashes	Fault	Possible Cause	Corrective Action
      x 6	Short Circuit Over Current	<ul style="list-style-type: none"> If fault occurs immediately after power-up: <ul style="list-style-type: none"> Shorted connection Defective cable Bad splice or failed motor If fault occurs while motor running: <ul style="list-style-type: none"> Over current due to trapped debris in pump Incorrect HP setting Amperage exceeded 72 amps on DC test or while running Incorrect wiring Phase to phase short circuit Phase to ground short circuit 	<ul style="list-style-type: none"> Verify wire connections at motor terminal block. Disconnect motor leads and use megger to check motor insulation resistance. If low reading, replace motor. If fault is still present after resetting the drive and removing motor leads, replace drive.
      x 7	Overheated Drive	<ul style="list-style-type: none"> High ambient temperature High internal drive temperature Direct sunlight Obstruction of airflow 	<ul style="list-style-type: none"> Check air screen for debris. Clean as necessary. Check for proper fan operation. Replace as necessary. Internal drive temperature must be below 80 °C before starting the motor, or below 70 °C before starting a motor after a Locked Pump fault. Refer to drive placement recommendations.
      rapid	Internal Fault	<ul style="list-style-type: none"> A fault was detected internal to the drive 	<ul style="list-style-type: none"> Contact Franklin Electric Technical Support. Unit may require replacement. Contact supplier.
     	Invalid Configuration	<ul style="list-style-type: none"> DIP switches are incorrectly set 	<ul style="list-style-type: none"> Verify settings per instruction.
     	Broken Pipe	<ul style="list-style-type: none"> Drive runs at full power for 10 minutes without reaching pressure setpoint Broken pipe or large leak is detected in the system Large water draw, such as a sprinkler system or filling a pool, does not allow system to reach pressure setpoint 	<ul style="list-style-type: none"> Check system for large leak or broken pipe. If the system contains a sprinkler system or is being used to fill a pool or cistern, disable the Broken Pipe Detection.
     	Transducer Fault	<ul style="list-style-type: none"> DIP SW2 position 1 is incorrectly set Pressure transducer is incorrectly wired, disconnected, damaged, or failed Pressure transducer signal is outside the expected range 	<ul style="list-style-type: none"> Verify DIP SW2 position 1 is in the XDRC (up) position if using a transducer. Inspect transducer wiring connections. Replace transducer.

Symptom Based Troubleshooting

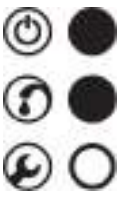
Table 85.

Condition	Display	Possible Cause	Corrective Action
No water		<ul style="list-style-type: none"> No supply voltage present 	<ul style="list-style-type: none"> Connect supply voltage. If correct voltage is present, replace drive.
		<ul style="list-style-type: none"> Pressure sensor circuit 	<ul style="list-style-type: none"> Verify water pressure is below system set point.
	 1 – 7	<ul style="list-style-type: none"> Fault detected Underload 	<ul style="list-style-type: none"> Refer to “Diagnostic Fault Codes” on page 106. Repair or replace the required foot valve for pump applications with suction lift.
	 rapid	<ul style="list-style-type: none"> Power surge Bad component Internal Fault 	<ul style="list-style-type: none"> Turn off power to clear the fault and verify input voltage. If repetitive, replace drive.
		<ul style="list-style-type: none"> Loose switch or cable connection Gulping water at pump inlet Motor may be running backwards 	<ul style="list-style-type: none"> If frequency max with low amps, check for closed valve or stuck check valve. If frequency max with high amps, check for hole in pipe. If frequency max with erratic amps, check pump operation, dragging impellers. This is not a drive problem. Check all connections, disconnect power, allow well to recover, and retry. Confirm max amps setting is set correctly. Confirm Underload Sensitivity is set correctly. Verify that motor connections are correct.
Pressure Fluctuations (Poor Regulation)		<ul style="list-style-type: none"> Pressure sensor placement and setting Pressure gauge placement Pressure tank size and pre-charge Leak in system Air in pump intake (lack of submergence) System response setting 	<ul style="list-style-type: none"> Correct pressure sensor placement and settings. Tank may be too small for system flow. This is not a drive problem. Disconnect power and check pressure gauge for drop. Set deeper in the well or tank; install a flow sleeve with airtight seal around drop pipe and cable. If fluctuation is only on branches before sensor, enable Steady Flow. Adjust System Response value.

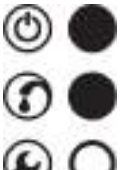
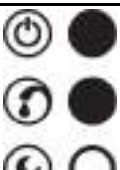
Table 85 (continued)

Condition	Display	Possible Cause	Corrective Action
Run On (pump won't stop)		<ul style="list-style-type: none"> • Pressure sensor placement and setting • Tank pre-charge pressure • Impeller damage • Leaky system • Sized improperly (pump can't build enough head) 	<ul style="list-style-type: none"> • Check frequency at low flows, pressure setting may be too close to pump max head. • Verify precharge at 70% if tank size is larger than minimum, increase precharge (up to 85%). • Verify that the system will build and hold pressure. • Enable bump and/or aggressive bump. • Increase minimum frequency.
Runs But Trips		<ul style="list-style-type: none"> • Check fault code and see corrective action 	<ul style="list-style-type: none"> • Proceed to fault code description and remedy.
Low Pressure		<ul style="list-style-type: none"> • Pressure sensor setting, pump sizing • High temperature 	<ul style="list-style-type: none"> • Adjust pressure sensor. Check pump rotation. • Check frequency at max flow and max pressure. • High ambient and/or drive temperature will cause drive to fold-back power and run with reduced performance.
High Pressure		<ul style="list-style-type: none"> • Pressure sensor setting, pump rotation, pump sizing • Shorted sensor wire 	<ul style="list-style-type: none"> • Adjust pressure sensor. • Remove sensor wire at Input Board. <ul style="list-style-type: none"> – If drive stops running, wire may be shorted. – If drive continues to run, replace drive. • Verify condition of sensor wire and repair or replace if necessary.
Audible Noises		<ul style="list-style-type: none"> • Fan • Drive • Hydraulic • Plumbing 	<ul style="list-style-type: none"> • For excessive fan noise, replace fan. • If fan noise is normal, drive will need to be relocated to a more remote area. • If hydraulic, try raising or lowering depth of pump. • Pressure tank location should be at entrance of water line into house.
RFI-EMI Interference		<ul style="list-style-type: none"> • Poor grounding • Wire routing • Radio or other electronic equipment too close to motor leads 	<ul style="list-style-type: none"> • Adhere to grounding and wire routing recommendations. • An additional external filter may be needed.
Intermittent drive or pump operation		<ul style="list-style-type: none"> • Open Circuit • Drive motor output is wired through the pump pressure switch 	<ul style="list-style-type: none"> • Wire the drive directly to the pump/motor, bypassing the pump pressure switch.

SubDrive Connect Maintenance

Diagnostic Fault Codes

Table 86.

Codes	Fault	Possible Causes	Corrective Action
F1	Motor Underload	<ul style="list-style-type: none"> High static, light loading pump Over-pumped well Broken shaft or coupling Blocked screen, worn pump Air/gas locked pump SubDrive not set properly for pump end Frequency near maximum with load less than configured underload sensitivity System is drawing down to pump inlet (out of water) Maximum frequency set too low for permanent magnet motor 	<ul style="list-style-type: none"> Reset Potentiometer for less sensitivity if not out of water Check pump rotation, reconnect if necessary for proper rotation If possible, set deeper in well to reduce possibility of air/gas locked pump Verify DIP switches are set properly Check Underload Sensitivity Setting (Potentiometer or Wi-Fi) Increase maximum frequency to 125Hz or more for permanent magnet motors - if maximum frequency must be below 125Hz, adjust underload sensitivity setting to a lower value.
F2	Undervoltage	<ul style="list-style-type: none"> Low line voltage, less than approximately 150 VAC Miswired input leads Loose connection at breaker or panel 	<ul style="list-style-type: none"> Line voltage needs to be 190 to 260 VAC Check incoming power connections and correct or tighten if necessary Correct incoming voltage. Check circuit breaker or fuses, contact power company
F3	Overcurrent or Locked Pump	<ul style="list-style-type: none"> Motor and/or pump misalignment Dragging motor and/or pump Motor and/or pump locked Abrasives in pump Excess motor cable length Amperage above SFL at 30 Hz Incorrect motor type selected 	<ul style="list-style-type: none"> Remove and repair or replace as required Reduce motor cable length. Adhere to Maximum Motor Cable Length table. Confirm the motor type on DIP SW1 Position 7 is set correctly.
F4	Incorrectly Wired	<ul style="list-style-type: none"> Wrong resistance values on main and start 	<ul style="list-style-type: none"> Check wiring, motor size and DIP switch setting. Adjust or repair as needed
F5	Output Open Phase	<ul style="list-style-type: none"> Loose connection Defective motor or drop cable Wrong motor 	<ul style="list-style-type: none"> Open reading on DC test at start. Check drop cable and motor resistance, tighten output connections, and repair or replace as necessary. Use dry motor to check drive functions. If drive runs and exhibits an underload fault, drive is good.
F6	Short Circuit	<ul style="list-style-type: none"> When fault is indicated immediately after power-up, short circuit caused by a shorted connection, defective cable, splice, or motor Amperage exceeded 25 amps on DC test at start or SF amps during running Incorrect output wiring, phase to phase short, phase to ground short in wiring or motor 	<ul style="list-style-type: none"> Check wiring and fix as necessary If fault is present after resetting and removing motor leads, replace drive

Table 86 (continued)

Codes	Fault	Possible Causes	Corrective Action
F7	Overheated Drive	<ul style="list-style-type: none"> High ambient temperature Direct sunlight Obstruction of airflow channel Fan blocked or inoperable, ambient above 122 °F (50 °C) 	<ul style="list-style-type: none"> Wait until drive temperature drops below 194 °F (90 °C) to restart Replace fans or fan module; or relocate drive as necessary Remove debris from fan intake/exhaust Remove and clean optional air screen kit (if installed)
F9	Internal PCB Fault	<ul style="list-style-type: none"> A fault was found internal to drive 	<ul style="list-style-type: none"> Contact your Franklin Electric Service Personnel Unit may require replacement. Contact your supplier.
F12	Overvoltage	<ul style="list-style-type: none"> High line voltage Internal voltage too high 	<ul style="list-style-type: none"> Check incoming power connections and correct or tighten terminals if necessary If line voltage is stable and measured below 260 VAC and problem persists, contact your Franklin Electric Service Personnel.
F14	Broken Pipe	<ul style="list-style-type: none"> Broken pipe or large leak is detected in the system Drive runs at full power for 10 minutes without reaching pressure setpoint Large water draw, such as a sprinkler system, does not allow system to reach pressure setpoint 	<ul style="list-style-type: none"> Check system for large leak or broken pipe If the system contains a sprinkler system or is being used to fill a pool or cistern, disable the Broken Pipe Detection.
F15	Phase Imbalance	<ul style="list-style-type: none"> Motor phase currents differ by 20% or more. Motor is worn internally Motor cable resistance is not equal Incorrect motor type setting (single- or three-phase) 	<ul style="list-style-type: none"> Check resistance of motor cable and motor windings. Verify motor type matched drive settings (single- or three-phase)
F16	Ground Fault	<ul style="list-style-type: none"> Motor output cable is damaged or exposed to water Phase to ground short 	<ul style="list-style-type: none"> Check motor cable insulation resistance with megger (while not connected to drive). Replace motor cable if needed.
F17	Inverter Temperature Sensor Fault	<ul style="list-style-type: none"> Internal temperature sensor is malfunctioning 	<ul style="list-style-type: none"> Contact your Franklin Electric Service Personnel If problem persists, unit may require replacement. Contact your supplier.
F18	PFC Temperature Sensor Fault		
F19	Communication Fault	<ul style="list-style-type: none"> Cable connection between Control Board and Power Board is loose or disconnected Internal circuit failure 	<ul style="list-style-type: none"> Check cable connection between Display/Wi-Fi Board and Main Control Board. If problem persists, unit may require replacement. Contact your supplier.
F22	Display/Wi-Fi Board Expected Fault	<ul style="list-style-type: none"> A fault was found internal to drive 	<ul style="list-style-type: none"> Contact your Franklin Electric Service Personnel Unit may require replacement. Contact your supplier.
F23	Main Board Startup Fault		

CONTROLS MAINTENANCE
SubDrive Connect Maintenance

Table 86 (continued)

Codes	Fault	Possible Causes	Corrective Action
F24	Invalid DIP Switch Setting	<ul style="list-style-type: none"> No DIP Switch set or more than one (1) DIP Switch set for Motor and/or Pump size Invalid combination of DIP switches for drive type (SD or MD mode), Motor hp, and Pump hp. 	<ul style="list-style-type: none"> Check DIP switch settings
F25	Moisture Sensor Fault	<ul style="list-style-type: none"> Moisture Sensor has detected moisture or water External device wired to the WET SENSOR terminal has satisfied the configured fault condition Input is incorrectly configured 	<ul style="list-style-type: none"> Check Moisture Sensor location for moisture or presence of water. Clean and dry area. If drive is stopped, power must be cycled to clear the fault. Ensure Moisture Sensor input is configured correctly
F26	Aux Input Fault	<ul style="list-style-type: none"> External device wired to the AUX IN terminal has satisfied the configured fault condition Input is incorrectly configured 	<ul style="list-style-type: none"> Ensure the Auxiliary Input is configured correctly
F27	Pressure Transducer Error	<ul style="list-style-type: none"> Pressure transducer has failed Pressure transducer is incorrectly wired Pressure transducer signal is outside of the expected range Pressure transducer is being used but DIP SW1 Position 5 is in the UP position Pressure Sensor is being used but SW1 Position 5 is in the DOWN position 	<ul style="list-style-type: none"> Replace pressure transducer Check pressure transducer wiring connections Ensure DIP SW1 Position 5 is in the correct position for the sensor type being used (DOWN for pressure transducer, UP for pressure switch)
F28	Real Time Clock Fault	<ul style="list-style-type: none"> Internal real time clock is not programmed Real time clock battery on Control Board is loose Real time clock battery is dead 	<ul style="list-style-type: none"> Ensure battery is properly inserted. If corrected, reconnect to drive using mobile app to reset the internal clock time Replace battery. If replaced, reconnect to the drive using the mobile app to reset the internal clock time
F41	Duplex Alternator Sensor Mismatch	<ul style="list-style-type: none"> Drives using the built-in Duplex Alternator function are configured with pressure sensor types that do not match 	<ul style="list-style-type: none"> Ensure the drives using the built-in Duplex Alternator function have matching pressure sensor types, either a traditional pressure sensor or a pressure transducer. Make sure the transducers are both PSI type or bar type, if both drives are configured with a pressure transducer.
F42	Duplex Alternator Firmware Mismatch	<ul style="list-style-type: none"> Drives using the built-in Duplex Alternator function have firmware versions that are not matched 	<ul style="list-style-type: none"> Update the firmware version of one or both drives to a matching firmware version using the FE Connect mobile app.
F43	Duplex Alternator Comm Fault	<ul style="list-style-type: none"> Improper Duplex Alternator cable connection Duplex Alternator cable is damaged 	<ul style="list-style-type: none"> Check Duplex Alternator cable connections Replace Duplex Alternator cable

Table 86 (continued)

Codes	Fault	Possible Causes	Corrective Action
F44	Duplex Alternator Unexpected Comm	<ul style="list-style-type: none"> Duplex Alternator cable is installed but Duplex Alternator function is only configured on one drive Drives are incorrectly configured 	<ul style="list-style-type: none"> Complete Duplex Alternator configuration on both drives Ensure both drives are configured properly. One drive must be configured as Pump 1, the other drive must be configured as Pump 2, and the Switching Interval must match.
F45	Duplex Alternator Demand Fault	<ul style="list-style-type: none"> Both drives are running and unable to satisfy the Primary Setpoint pressure 	<ul style="list-style-type: none"> Inspect each system for proper pump operation

Power down, disconnect leads to the motor and power up the SubDrive:

- If the SubDrive does not give an “open phase” fault (F5), then there is a problem with the SubDrive.
- Connect the SubDrive to a dry motor. If the motor goes through DC test and gives “underload” fault (F1), the SubDrive is working properly.

Symptom Based Troubleshooting

Table 87.

Condition	Display	Possible Cause	Corrective Action
No water	None	<ul style="list-style-type: none"> No supply voltage present Display board cable disconnected or loose 	<ul style="list-style-type: none"> Verify cable connection between Power Board and Control Board If correct voltage is present, replace drive
	Green "_"	<ul style="list-style-type: none"> Pressure sensor circuit 	<ul style="list-style-type: none"> Verify water pressure is below system set point If Pressure Input Board break-away tab is removed, ensure auxiliary device is connected and closed circuit Jumper wires together at pressure sensor; if pump starts, replace sensor If pump doesn't start, check sensor connection at Pressure Input Board; if loose, repair If pump doesn't start, jumper sensor connection at Pressure Input Board. If pump starts, replace wire If pump doesn't start with sensor Pressure Input Board connection jumpered, replace Pressure Input Board If pump doesn't start with new Pressure Input Board, replace
	Red Fault Codes	<ul style="list-style-type: none"> Fault detected 	<ul style="list-style-type: none"> Refer to "Diagnostic Fault Codes" on page 110 .
	Green Motor Frequency	<ul style="list-style-type: none"> Incorrect motor or pump settings Loose switch or cable connection Motor may be running backwards Gulping water at pump inlet Frequency max and amps high Frequency max and amps erratic with dragging impellers 	<ul style="list-style-type: none"> Verify Maximum Frequency setting. If this setting was reduced below maximum value, increase Verify motor/pump ratings and match to motor/pump settings on drive (DIP switch or Wi-Fi) Verify motor connections Frequency max, amps low, check for closed valve, or stuck check valve Check all piping connections Disconnect power, allow well to recover, and restart Check for hole in pipe Check pump operation and for dragging impellers
Pressure Fluctuations (Poor Regulation)	Green Motor Frequency	<ul style="list-style-type: none"> Pressure sensor placement and setting Pressure gauge placement Pressure tank size and precharge Tank may be too small for system flow Leak in system Air in pump intake (lack of submergence) System response setting 	<ul style="list-style-type: none"> Correct pressure sensor placement and settings Disconnect power and check pressure gauge for drop Set deeper in the well or tank. Install a flow sleeve with airtight seal around drop pipe and cable If fluctuation is only on branches before sensor, enable Steady Flow Change tank size configuration Reduce frequency output range Adjust System Response value
Run On (pump won't stop)	Green Motor Frequency	<ul style="list-style-type: none"> Pressure sensor placement and setting Tank pre-charge pressure Impeller damage Leaky system Sized improperly (pump can't build enough head) 	<ul style="list-style-type: none"> Check frequency at low flows. Pressure setting may be too close to pump max head Verify precharge at 70% if tank size is larger than minimum. Increase precharge (up to 85%). Verify that the system will build and hold pressure Enable bump and/or aggressive bump Increase minimum frequency

Table 87 (continued)

Condition	Display	Possible Cause	Corrective Action
Runs But Trips	Flashing Red	<ul style="list-style-type: none"> A fault has occurred 	<ul style="list-style-type: none"> Proceed to fault code description and remedy
Low Pressure	Green Motor Frequency	<ul style="list-style-type: none"> Pressure sensor setting, pump rotation, pump sizing High temperature 	<ul style="list-style-type: none"> Adjust pressure sensor, check pump rotation. Check frequency at max flow, check max pressure High ambient and/or drive temperature will cause drive to fold-back power and run with reduced performance
High Pressure	Green Motor Frequency	<ul style="list-style-type: none"> Pressure sensor setting Shorted sensor wire 	<ul style="list-style-type: none"> Adjust pressure sensor Verify condition of sensor wire and repair. Remove sensor wire at Pressure Input Board. <ol style="list-style-type: none"> if drive stops running, wire may be shorted if drive continues to run, replace Pressure Input Board If drive continues to run after replacing Pressure Input board, replace drive
Audible Noises	Green Motor Frequency	<ul style="list-style-type: none"> Fan Hydraulic Plumbing 	<ul style="list-style-type: none"> For excessive fan noise, replace fan If fan noise is normal, drive will need to be relocated to a more remote area If a hydraulic problem, try raising or lowering depth of pump Pressure tank location should be at entrance of water line into house
No Display	None	<ul style="list-style-type: none"> Display board cable disconnected or loose 	<ul style="list-style-type: none"> Verify cable connection between main control board and display
Cannot Connect to Drive Bluetooth	FE Connect Light On Soid	<ul style="list-style-type: none"> Attempting to connect to incorrect drive Out of Wi-Fi range of drive (more than 100 ft line-of-site) 	<ul style="list-style-type: none"> Ensure the Wi-Fi SSID (hotspot name) you are connecting to matches the correct drive Move so Wi-Fi signal is closer to the drive if walls or floors are between you and the drive Wi-Fi module not responding, cycle power to drive Cycle Wi-Fi radio on mobile device, refresh Wi-Fi connection list
	FE Connect Light Off	<ul style="list-style-type: none"> Wi-Fi timeout expired 	<ul style="list-style-type: none"> If more than fifteen (15) minutes since last power cycle, cycle power to drive If more than one (1) hour since last disconnection from Wi-Fi, cycle power to drive
RFI-EMI Interference	Green Motor Frequency	<ul style="list-style-type: none"> Poor grounding Wire routing 	<ul style="list-style-type: none"> Adhere to grounding and wire routing recommendations An additional external filter may be needed.
System Regulates but displays 199P	Green 199P	<ul style="list-style-type: none"> The pressure in the system is 199 psi or higher 	<ul style="list-style-type: none"> The max pressure the display can show is 199 psi. Use the pressure gauge or Wi-Fi / FE-Connect app to view the system pressure.

SubDrive Connect Plus Maintenance

Diagnostic Fault Codes

Table 88.

Codes	Fault	Possible Causes	Corrective Action
F1	Motor Underload	<ul style="list-style-type: none"> Over-pumped well Broken shaft or coupling Blocked screen, worn pump Air/gas locked pump SubDrive not set properly for pump end Underload Sensitivity setting incorrect Drive is in thermal foldback 	<ul style="list-style-type: none"> Frequency near maximum with load less than configured underload sensitivity (SubDrive Connect Plus mobile app) System is drawing down to pump inlet (out of water) High static, light loading pump - reset Underload Sensitivity setting (in the programming menu and mobile app) if not out of water Check pump rotation, reconnect if necessary for proper rotation Air/gas locked pump - if possible, set deeper in well to reduce Verify MAX AMPS setting (in the programming menu and mobile app) is correct. For FE MagForce application, make sure MAX AMPS matches pump load's rated current. If the drive is in thermal foldback, see corrective actions for fault code F7.
F2	Undervoltage	<ul style="list-style-type: none"> Low line voltage Miswired input leads Loose connection at breaker or panel 	<ul style="list-style-type: none"> Line voltage low, less than approximately: <ul style="list-style-type: none"> - 155 VAC (normal 230 operating range = 190 to 260) - 290 VAC (normal 460 operating range = 380 to 520) Check incoming power connections and correct or tighten if necessary Incorrect incoming voltage — check fuses, contact power company
F3	Overcurrent or Locked Pump	<ul style="list-style-type: none"> Motor and/or pump misalignment Dragging motor and/or pump Motor and/or pump locked Abrasives in pump Excess motor cable length 	<ul style="list-style-type: none"> Amperage is above MAX AMPS at minimum frequency Remove and repair or replace as required Reduce motor cable length. Adhere to Maximum Motor Cable Length table. For FE MagForce application, verify motor model selection, pump load, and max amps.
F4	Incorrectly Wired	<ul style="list-style-type: none"> Input and output wires are swapped 	<ul style="list-style-type: none"> Check wiring, check motor size, adjust or repair as needed
F5	Output Open Phase	<ul style="list-style-type: none"> Loose connection Defective motor or drop cable Wrong motor 	<ul style="list-style-type: none"> Open reading on DC test at start. Check drop cable and motor resistance, tighten output connections, repair or replace as necessary. Use dry motor to check drive functions. If drive runs and exhibits an underload fault, drive is good.
F6	Short Circuit	<ul style="list-style-type: none"> When fault is indicated immediately after power-up, short circuit caused by a shorted connection, defective cable, splice, or motor 	<ul style="list-style-type: none"> Amperage exceeded 25 amps on DC test at start or SF amps during running Incorrect output wiring, phase to phase short, phase to ground short in wiring or motor If fault is present after resetting and removing motor leads, replace drive
F7	Overheated Drive	<ul style="list-style-type: none"> High ambient temperature Direct sunlight Obstruction of airflow channel 	<ul style="list-style-type: none"> The drive has exceeded max rated temperature, needs to drop below 167 °F (75 °C) to restart Fans blocked or inoperable, ambient above 104 °F (40 °C), direct sunlight, air flow channel blocked Replace fans or fan module; or relocate drive as necessary Remove debris from fan intake/exhaust

Table 88 (continued)

Codes	Fault	Possible Causes	Corrective Action
F8	Over Pressure	<ul style="list-style-type: none"> Measured pressure exceeds setting 	<ul style="list-style-type: none"> Troubleshoot system to locate reason for high pressure
F9	Internal PCB Fault	<ul style="list-style-type: none"> A fault was found internal to drive 	<ul style="list-style-type: none"> Contact your Franklin Electric Service Personnel Unit may require replacement. If problem persists, note the sub-fault number on the display before contacting the FE Service Personnel.
F12	Overvoltage	<ul style="list-style-type: none"> High line voltage Internal voltage too high 	<ul style="list-style-type: none"> Line voltage high, greater than approximately: <ul style="list-style-type: none"> - 290 VAC (normal 230 operating range = 190 to 260) - 600 VAC (normal 460 operating range = 380 to 520) Check incoming power connections and correct or tighten terminals if necessary If line voltage is stable and measured below 260 VAC and problem persists, contact your Franklin Electric Service Personnel.
F14	Broken Pipe	<ul style="list-style-type: none"> Broken pipe or large leak is detected in the system Drive runs at full power for 10 minutes without reaching pressure setpoint Large water draw, such as a sprinkler system, does not allow system to reach pressure setpoint Broken Pipe Pressure setting is higher than the active Setpoint pressure setting 	<ul style="list-style-type: none"> Check system for large leak or broken pipe If the system contains a sprinkler system or is being used to fill a pool or cistern, disable the Broken Pipe Detection Adjust the Broken Pipe Pressure setting to a value lower than any active Setpoint pressure settings.
F15	Phase Imbalance	<ul style="list-style-type: none"> Motor phase currents differ by 20% or more. Motor is worn internally Motor cable resistance is not equal 	<ul style="list-style-type: none"> Check resistance of motor cable and motor windings. Phase imbalance and loss of phase may indicate similar issues.
F19	Communication Fault	<ul style="list-style-type: none"> Cable connection between Control Board and Power Board is loose or disconnected Internal circuit failure 	<ul style="list-style-type: none"> Check cable connection between Control Board and Power Board. The cable connection on the control board is located on the back side of the control board. If problem persists, unit may require replacement. Contact your supplier.
F22	Control Board Fault	<ul style="list-style-type: none"> EEPROM error Bluetooth error 	<ul style="list-style-type: none"> Cycle power to see if fault resets. Check cable connection between Control Board and Power Board. Check all programming parameters. Verify all programming parameters Reset the drive to factory default settings, refer to If problem persists, note the sub-fault number on the display before contacting the FE Service personnel.
F25	Moisture Sensor Faults	<ul style="list-style-type: none"> Moisture Sensor has detected moisture or water External device wired to the WET SENSOR terminal has satisfied the configured fault condition Input is incorrectly configured 	<ul style="list-style-type: none"> Check Moisture Sensor location for moisture or presence of water. Clean and dry area. Drive will restart when moisture or water is no longer detected. Ensure Moisture Sensor input is configured/wired correctly

CONTROLS MAINTENANCE
SubDrive Connect Plus Maintenance

Table 88 (continued)

Codes	Fault	Possible Causes	Corrective Action
F27	Pressure Transducer Error	<ul style="list-style-type: none"> Pressure transducer has failed Pressure transducer is incorrectly wired Pressure transducer signal is outside of the expected range Pressure transducer is disconnected Incorrect sensor type setting 	<ul style="list-style-type: none"> Check pressure transducer wiring connections; tighten or correct, if necessary Ensure sensor type setting is correct Replace pressure transducer
F28	Real Time Clock Fault, not displayed, but logged.	<ul style="list-style-type: none"> Internal real time clock is not programmed Real time clock battery on Control Board is loose Real time clock battery is dead 	<ul style="list-style-type: none"> Ensure battery is properly inserted. If corrected, reconnect to drive using mobile app to reset the internal clock time Replace battery. If replaced, reconnect to the drive using the mobile app to reset the internal clock time
F29	RTD Temperature Alarm	<ul style="list-style-type: none"> Motor windings are getting hot 	<ul style="list-style-type: none"> Shut off the system to allow the PMA to cool down
F30	RTD Temperature Fault	<ul style="list-style-type: none"> Motor windings are too hot 	<ul style="list-style-type: none"> Shut off the system to allow the PMA to cool down Persistent faults may require pulling the PMA and installing a cooling sleeve (AIM manual)
F31	Input Phase Loss	<ul style="list-style-type: none"> DC bus ripple amplitude exceeds a set value 	<ul style="list-style-type: none"> Input phase imbalance and loss of phase may indicate similar issues Phase imbalance could be caused by an Open Delta Power Supply. Measure and confirm adequate voltage at the drive input (L1-L2, L2-L3, and L3-L1). Confirm input power leads are properly inserted into the input power terminal block and confirm proper torque.
F32	No Motor	<ul style="list-style-type: none"> All three phases have current below 15% of motor FLA for 250 ms Motor circuit has open or loose connection 	<ul style="list-style-type: none"> Refer to the motor's owner's manual for troubleshooting Tighten motor connections
F35	Incompatible Firmware	<ul style="list-style-type: none"> Firmware of Power board and Control board are incompatible 	<ul style="list-style-type: none"> Update firmware of boards to latest version
F37	Fan Speed Fault	<ul style="list-style-type: none"> One or more of the internal fans are not working Airflow is impeded 	<ul style="list-style-type: none"> Check fan connections to the Control Board. Fan blocked or inoperable, ambient above 104 °F (40 °C), direct sunlight, air flow channel blocked Replace internal stirring fans or relocate drive as necessary Remove debris from fan intake/exhaust
F38	Internal Over Temperature	<ul style="list-style-type: none"> High ambient temperature Drive is in direct sunlight Airflow is impeded 	<ul style="list-style-type: none"> The drive has exceeded max rated internal temperature of 176 °F (80 °C), and needs to drop below 167 °F (75 °C) to restart Replace fan or relocate drive as necessary Remove debris from fan intake/exhaust
F39	RTD Device Missing	<ul style="list-style-type: none"> PT100 Select is set to "Enabled" and no RTD device is connected to the drive. 	<ul style="list-style-type: none"> Switch PT100 Select to "Disabled" Connect the RTD device to the drive
F41	MultiDrive Sensor Mismatch	<ul style="list-style-type: none"> Drives using the built-in MultiDrive function are configured with pressure sensor types that do not match 	<ul style="list-style-type: none"> Drives using the built-in MultiDrive function must have matching pressure sensor types, either a traditional pressure sensor or a pressure transducer. If both drives are configured with a pressure transducer, the transducers must both be PSI type or bar type.

Table 88 (continued)

Codes	Fault	Possible Causes	Corrective Action
F42	MultiDrive Firmware Mismatch	<ul style="list-style-type: none"> Drives using the built-in MultiDrive function have firmware versions that are not matched 	<ul style="list-style-type: none"> Firmware version of one or more drives must be updated to a matching firmware version using the SubDrive Connect Plus mobile app.
F43	MultiDrive Comm Fault	<ul style="list-style-type: none"> Improper MultiDrive cable connection MultiDrive cable is damaged 	<ul style="list-style-type: none"> Check MultiDrive cable connections Replace MultiDrive cable Check dip switch setting for terminating resistor.

Symptom Based Troubleshooting

Table 89.

Condition	Display	Possible Cause	Corrective Action
No water	None	<ul style="list-style-type: none"> No supply voltage present Control Board cable disconnected or loose 	<ul style="list-style-type: none"> Verify cable connection between Power Board and Control Board If correct voltage is present, replace drive
	Home Screen at 0 Hz	<ul style="list-style-type: none"> Pressure sensor circuit 	<ul style="list-style-type: none"> Verify water pressure is below system set point Ensure auxiliary device is connected and closed circuit Jumper wires together at pressure sensor; if pump starts, replace sensor If pump doesn't start, check sensor connection at J14; if loose, repair If pump doesn't start, jumper sensor connection at J14. If pump starts, replace wire If pump doesn't start with new sensor, replace drive
	Fault Code	<ul style="list-style-type: none"> Fault detected 	<ul style="list-style-type: none"> Refer to “Diagnostic Fault Codes” on page 116
	Motor Frequency	<ul style="list-style-type: none"> Drive and motor are operating, but the max frequency was set too low to lift/pump/produce water Loose switch or cable connection Incorrect motor or pump settings Motor may be running backwards Gulping water at pump inlet 	<ul style="list-style-type: none"> Verify Maximum Frequency setting. Verify motor/pump ratings and match to motor/pump settings on drive Verify motor connections Frequency max, amps low, check for closed valve, or stuck check valve Frequency max, amps high, check for hole in pipe Frequency max, amps erratic, check pump operation, dragging impellers This is not a drive problem Check all connections Disconnect power, allow well to recover and retry
Pressure Fluctuations (Poor Regulation)	Motor Frequency	<ul style="list-style-type: none"> Pressure sensor placement and setting Pressure gauge placement Pressure tank size and pre-charge Leak in system Air in pump intake (lack of submergence) System response setting 	<ul style="list-style-type: none"> Correct pressure sensor placement and settings Tank may be too small for system flow This is not a drive problem Disconnect power and check pressure gauge for drop Set deeper in the well or tank; install a flow sleeve with airtight seal around drop pipe and cable Change tank size configuration Reduce frequency output range Adjust System Response value

CONTROLS MAINTENANCE
SubDrive Connect Plus Maintenance

Table 89 (continued)

Condition	Display	Possible Cause	Corrective Action
Run On (pump won't stop)	Motor Frequency	<ul style="list-style-type: none"> Pressure sensor placement and setting Tank pre-charge pressure Impeller damage Leaky system Sized improperly (pump can't build enough head) 	<ul style="list-style-type: none"> Check frequency at low flows, pressure setting may be too close to pump max head Verify precharge at 70% if tank size is larger than minimum, increase precharge (up to 85%) Verify that the system will build and hold pressure Enable bump and/or aggressive bump Increase minimum frequency
Runs But Trips	None	<ul style="list-style-type: none"> Check fault code and see corrective action 	<ul style="list-style-type: none"> Proceed to fault code description and remedy
Low Pressure	Motor Frequency	<ul style="list-style-type: none"> Pressure sensor setting, pump rotation, pump sizing High temperature 	<ul style="list-style-type: none"> Adjust pressure sensor Check frequency at max flow, check max pressure High ambient and/or drive temperature will cause drive to foldback power and run with reduced performance
High Pressure	Motor Frequency	<ul style="list-style-type: none"> Pressure sensor setting Shorted sensor wire 	<ul style="list-style-type: none"> Adjust pressure sensor Remove sensor wire at Control Board, if drive stops running, wire may be shorted Remove sensor wire at Control Board, if drive continues to run, replace Control Board Remove sensor wire at new Control Board, if drive continues to run, replace drive Verify condition of sensor wire and repair or replace if necessary
Audible Noises	Motor Frequency	<ul style="list-style-type: none"> Fan, hydraulic, plumbing dV/dt filter 	<ul style="list-style-type: none"> For excessive fan noise, replace fan If fan noise is normal, drive will need to be relocated to a more remote area If hydraulic, try raising or lowering depth of pump Pressure tank location should be at entrance of water line into house For EMI noise, change switching frequency to 8 kHz if using a CEN model for surface applications, otherwise it is locked at 2.5 kHz.
No Display	None	<ul style="list-style-type: none"> Control Board cable disconnected or loose 	<ul style="list-style-type: none"> Verify cable connection between Power Board and Control Board
Cannot Connect to Drive Bluetooth	Bluetooth Icon Off	<ul style="list-style-type: none"> Attempting to connect to incorrect drive Out of Bluetooth range of drive 	<ul style="list-style-type: none"> Ensure the Bluetooth SSID (Drive ID) you are connecting to matches the drive you wish to connect to Bluetooth range is 100 feet line-of-sight, must be closer to drive if walls or floors are between you and the drive Bluetooth module not responding, cycle power to drive Cycle Bluetooth radio on mobile device, refresh Bluetooth connection list
RFI-EMI Interference	Motor Frequency	<ul style="list-style-type: none"> Poor grounding Wire routing 	<ul style="list-style-type: none"> Adhere to grounding and wire routing recommendations An additional external filter may be needed.

Cerux X-Drive Maintenance

Troubleshooting

Error Messages: When the drive detects a fault or warning, an error message displays on the screen showing the current problem condition. In some cases the fault can be cleared by pressing the **STOP/RESET** button.



Fault Records: In addition, the drive records up to 30 of the most recent faults. These can be accessed by pressing the **F3** key. Use the arrow keys to scroll through the list. For more information about a selected fault, press the **ENTER** key to display details about the occurrence, including date, time, output frequency, output current, and other related data.



NOTE: Fault records can also be located through **[PROT-51]** to **[PROT-56]**, or by pressing **MENU**, **BACK**, or **DOWN**, or **FAULT**.

Using the displayed fault title, refer to the following table for troubleshooting details.

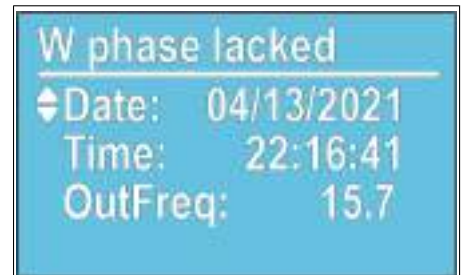

CONTROLS MAINTENANCE
Cerus X-Drive Maintenance

Diagnostic Fault Codes

NOTE: For more details, please refer to the X-Drive Owner's Manual.

Table 90.

Fault Display	Possible Cause	Corrective Action
ACE (48) ACI loss	<ul style="list-style-type: none"> Loose or broken connection Sensor failure Drive failure 	<ul style="list-style-type: none"> Check the ACI wiring Check if the ACI signal is less than 4mA (2V)
ACE(88) AVI loss	<ul style="list-style-type: none"> Loose or broken connection Sensor failure Drive failure 	<ul style="list-style-type: none"> Check the AVI1 and AVI2 wiring Check if the AVI1 or AVI2 signal is less than 2V (4mA)
ATJM (188) Anti-Jam Failed	<ul style="list-style-type: none"> Impeller or pump is clogged with debris Load is larger than motor Bad motor 	<ul style="list-style-type: none"> Remove debris impeller/pump Replace and resize motor Attempt to start motor without impeller/pump. If problem persists, replace motor
AUE (40) AUE 1 (142) AUE 2 (143) AUE 3 (144) AUE 4 (148) Auto tuning error	<ul style="list-style-type: none"> STOP pressed during tuning Incorrect motor capacity Accel/Decel time to short Incorrect motor wiring Locked rotor or motor error Sine-filter installed 	<ul style="list-style-type: none"> Restart tuning. Check motor capacity and parameter settings. Check cabling between drive and motor. If sine-filter is installed, remove filter for auto-tuning.
bF (60) Braking fault	<ul style="list-style-type: none"> Hardware error EMI interference 	<ul style="list-style-type: none"> Check wiring and grounding for possible interference. If error still exists after RESET, please call technical support.
BKPI (180) Broken Pipe	<ul style="list-style-type: none"> Pipe broken or hole in tubing between pump and sensor Pump sized too small Parameters set incorrectly Check valve above pump stuck close 	<ul style="list-style-type: none"> Fix break, hole, or leak in piping Replace pump with larger one Review functionality and change parameters for broken pipe Unclog check valve
CADE (106) CAN bus Add Err	<ul style="list-style-type: none"> Incorrect address setting 	<ul style="list-style-type: none"> Reset address
CardiBTc (181) Internal BT	<ul style="list-style-type: none"> Improper card installation Card ID not set Hardware failure 	<ul style="list-style-type: none"> Check card installation. Verify [Comm-30]. Replace card.
CbFE (104) CFrE (107) CAN bus off	<ul style="list-style-type: none"> CANopen card not installed CANopen speed incorrect EMI Interference Communication cable broken Firmware update 	<ul style="list-style-type: none"> Check Comm card installation Check communications settings Check wiring and grounding for possible interference Make sure communication circuit is wired in series For CFrE error, reset parameters and station address
cd1 (33) lbs sensor Err	<ul style="list-style-type: none"> Hardware failure 	<ul style="list-style-type: none"> If error still exists after power cycle, please call Technical Support.
cd2 (34) lbs sensor Err	<ul style="list-style-type: none"> Hardware failure 	<ul style="list-style-type: none"> If error still exists after power cycle, please call Technical Support.
cd3 (35) lbs sensor Err	<ul style="list-style-type: none"> Hardware failure 	<ul style="list-style-type: none"> If error still exists after power cycle, please call Technical Support.
CE2 (55) PC Err address CE1 (54) PC Err command CE3 (56) PC Err data CE4 (57) PC slave fault	<ul style="list-style-type: none"> Incorrect communication command from the master unit Malfunction caused by interference Different communication setting from the master unit Disconnection or bad connection of the cable 	<ul style="list-style-type: none"> Check if the communication command is correct. Verify the wiring and grounding of the communication circuit. It is recommended to separate the communication circuit from the main circuit, or wire in 90 degree for effective anti-interference performance. Check if the setting for [Comm-02] is the same as the setting for the master unit. Check the cable and replace it if necessary.
CE10 (58) PC time out	<ul style="list-style-type: none"> The upper unit does not transmit the communication command within [Comm-03] setting time Malfunction caused by interference Different communication setting from the master unit Disconnection or bad connection of the cable 	<ul style="list-style-type: none"> Check if the master unit transmits the communication command within [Comm-03]. Verify the wiring and grounding of the communication circuit. It is recommended to separate the communication circuit from the main circuit, or wire in 90 degree for effective anti-interference performance. Check if the setting for [Comm-02] is the same as the setting for the master unit. Check the cable and replace it if necessary.

Table 90 (continued)

Fault Display	Possible Cause	Corrective Action
cF1 (30) EEPROM write err	<ul style="list-style-type: none"> Hardware failure 	<ul style="list-style-type: none"> If condition still exists after power restart, please call Technical Support.
cF2 (31) EEPROM read err	<ul style="list-style-type: none"> Hardware failure 	<ul style="list-style-type: none"> If condition still exists after power restart, please call Technical Support.
CGdE (101) Guarding T-out	<ul style="list-style-type: none"> Guarding time is too short EMI Interference Faulting communication cable 	<ul style="list-style-type: none"> Increase guarding time and detection times. Verify wiring and grounding of communication circuit. Make sure communication circuit is wired in series. Use CANopen cable or add terminating resistance.
CHbE (102) Heartbeat T-out	<ul style="list-style-type: none"> Heartbeat time is too short EMI Interference Faulting communication cable 	<ul style="list-style-type: none"> Increase heartbeat time. Verify wiring and grounding of communication circuit. Make sure communication circuit is wired in series. Use CANopen cable or add terminating resistance.
CIdE (105) CAN bus Index Err	<ul style="list-style-type: none"> Incorrect index setting 	<ul style="list-style-type: none"> Reset index
dEb (62) Dec Energy back	<ul style="list-style-type: none"> Unstable power source Power is off Other large loads in power system 	<ul style="list-style-type: none"> Check power supply capacity Separate other large loads
DPR (177) Damper Fault	<ul style="list-style-type: none"> Damper is not opening Limit switch failure Incorrect wiring Incorrect settings 	<ul style="list-style-type: none"> Check limit switch connections and function Check damper relay connections and damper function Verify all damper related parameters
EF (49) External Fault	<ul style="list-style-type: none"> Multi-function input terminal that is set to external fault has been activated. 	<ul style="list-style-type: none"> Deactivate input terminal with function set to external fault Check Normally Open / Normally Closed settings for DI NO/NC [IO-46]
EF1 (50) Emergency stop	<ul style="list-style-type: none"> Multi-function input terminal that is set to emergency stop has been activated. 	<ul style="list-style-type: none"> Deactivate input terminal with function set to emergency stop Check Normally Open / Normally Closed settings DI NO/NC [IO-46]
EoL1 (22) Thermal relay 1	<ul style="list-style-type: none"> Motor shaft lock The load is too large V/F voltage is too high Overload during low-speed operation. When using a general motor, even it operates below rated current, an overload may still occur during low-speed operation. When using VFD dedicated motors, [PROT-16] = 0 (electronic thermal relay selection motor 1 = inverter motor) Incorrect value of electronic thermal relay [PROT-17] The maximum motor frequency is set too low Torque compensation is too large Motor fan error Unbalanced three-phase impedance of the motor 	<ul style="list-style-type: none"> Remove the shaft lock. Reduce the load and increase the motor capacity. Adjust settings for V/F curve, especially the setting value for the mid-point voltage (if the mid-point voltage is set too low, the load capacity decreases at low speed). Decrease low-speed operation time. Replace the drive with a dedicated to VFD model. Increase the motor capacity. [PROT-16] = 1 electronic thermal relay selection motor 1 = standard motor (with fan on the shaft). Reset to the correct motor rated current and [PROT-17]. Reset to the correct motor rated frequency. Adjust the torque compensation (refer to [MOTOR-17]) until the current reduces and the motor does no stall. Check the status of the fan, or replace the fan. Replace the motor.
FANL (91) FAN PWR lost	<ul style="list-style-type: none"> Fan not connected Broken fan wire Damaged fan 	<ul style="list-style-type: none"> Check that fan connector has correctly mated with drive connection. Check wires going to fan. If broken, replace fan. Check fan works by power cycling the drive. If fan does not run for 5 seconds at initial turn-on, replace fan.
Fire (74) Override	<ul style="list-style-type: none"> A secondary fault is present Too many faults during FO Retry Delay FO mode initiated prematurely causing secondary fault 	<ul style="list-style-type: none"> View fault log to identify active fault. Review fault log to diagnosis system issues. Review FO mode setup including digital input assignments.
FStp (90) Force Stop	<ul style="list-style-type: none"> [SET-61] = 1: keypad STOP button is valid Press STOP button during PLC operation 	<ul style="list-style-type: none"> Check if it is necessary to set [SET-61] = 0, so the keypad STOP button is invalid Verify the timing of STOP function

CONTROLS MAINTENANCE
Cerus X-Drive Maintenance

Table 90 (continued)

Fault Display	Possible Cause	Corrective Action
GFF (4) Ground Fault	<ul style="list-style-type: none"> Motor failure Broken motor cable Capacitance cable and ground EMI Interference Drive failure 	<ul style="list-style-type: none"> Check motor and wiring with meg-ohm meter. If cable exceeds 100 m (328 ft) decrease carrier frequency. Verify grounding of communication circuit. Ensure separation of communication circuits and high-voltage wiring. Check whether the IGBT power module is damaged.
Hd0 (36) cc HW error	<ul style="list-style-type: none"> Hardware failure 	<ul style="list-style-type: none"> If condition still exists after power restart, please call Technical Support.
Hd1 (37) oc HW error	<ul style="list-style-type: none"> Hardware failure 	<ul style="list-style-type: none"> If condition still exists after power cycle, please call Technical Support.
Hd2 (38) ov HW error	<ul style="list-style-type: none"> Hardware failure 	<ul style="list-style-type: none"> If condition still exists after power cycle, please call Technical Support
Hd3 (39) occ HW error	<ul style="list-style-type: none"> Hardware failure 	<ul style="list-style-type: none"> If condition still exists after power cycle, please call Technical Support.
HLD (176) High Load	<ul style="list-style-type: none"> Motor and/or pump misalignment Dragging motor and/or pump Motor and/or pump locked Abrasives in pump Excess motor cable length 	<ul style="list-style-type: none"> Amperage is above MAX AMPS at minimum frequency. Remove and repair or replace as required. Reduce motor cable length. Adhere to Maximum Motor Cable Length table. For FE MagForce application, verify motor model selection, pump load, and max amps.
ictE (111) InrCom Time Out	<ul style="list-style-type: none"> EMI Interference Communication cable broken 	<ul style="list-style-type: none"> Check Comm card installation. Check communications settings. Check wiring and grounding for possible interference.
LvA (11) Lv at accel	<ul style="list-style-type: none"> Power voltage changes Load is too large Improper wiring at +1 and +2 Generator voltage dips 	<ul style="list-style-type: none"> Check if the input voltage is normal. Check for possible sudden load. Adjust setting of [PROT-03]. Check DC reactor connection. If powered by a generator, increase the throttle. If powered by a generator, replace generator with large one.
Lvd (12) Lv at decel	<ul style="list-style-type: none"> Power-off Power voltage changes Start up the motor with large capacity Sudden load DC bus 	<ul style="list-style-type: none"> Improve power supply condition. Adjust voltage to the power range of the drive. Check the power system. Increase the capacity of power equipment. Reduce the load and increase the drive capacity. Install DC reactor.
Lvn (13) Lv at normal SPD	<ul style="list-style-type: none"> Power voltage changes Sudden load changes Improper wiring at +1 and +2 	<ul style="list-style-type: none"> Check if the input voltage is normal. Check for possible sudden load. Adjust setting of [PROT-03]. Check DC reactor connection. If powered by a generator, increase the throttle. If powered by a generator, replace generator with large one.
LvS (14) Lv at Stop	<ul style="list-style-type: none"> Incorrect drive model Power voltage change Hardware failure 	<ul style="list-style-type: none"> Check if the input voltage is normal. Check for possible sudden load. Adjust setting of [PROT-03]. Check DC reactor connection. Cycle the power. If error still exists, please call Technical Support. If powered by a generator, increase the throttle. If powered by a generator, replace generator with large one.
MVWS (183) M-VFD Wrong Set	<ul style="list-style-type: none"> Wrong parameter values for [ADV-35], [ADV-36], [SET-07], and [SET-17] Multiple masters on network 	<ul style="list-style-type: none"> Verify settings match master drive. To identify master drive, set [SET-58] to 23_Comm Role. On screen, 0=No Role, 1=Master, and 2=Followers. If network has multiple masters, make sure each drive on network has unique Mult-VFD [ADV-37] and that value is equal or less than Multi-VFD Set [ADV-35]. If network has multiple masters, check communication wiring between drives and replace wiring as needed.

Table 90 (continued)

Fault Display	Possible Cause	Corrective Action
MVWV (184) M-VFD Wrong Ver	<ul style="list-style-type: none"> Drive has different firmware VFD-49 than master 	<ul style="list-style-type: none"> Reprogram drive with same firmware as master. To identify master drive, set [SET-58] to 23_Comm Role. On screen, 0=No Role, 1=Master, and 2=Follower. Replace drive with one that has matching firmware. Remove drive from network and operate independent.
NOFL (178) No Flow(l)	<ul style="list-style-type: none"> No water (dry well) No-flow switch is Normally Closed (closed when water is moving) Nuisance tripping Water flow is too low Pump has not finished filling pipe with water 	<ul style="list-style-type: none"> Refill cistern or wait for well to fill with water. Change DI NO/NC [IO-46] for designated input to NC. Review installation instructions with No-Flow Switch which include installing on long straight pipes (no turns) and orientation (horizontal). Calibrate flow switch. Increase Prime Time.
ocA (1) Oc at accel	<ul style="list-style-type: none"> Acceleration time is too short Short circuit at motor output due to poor insulation wiring Check for possible burnout or aging insulation of the motor The load is too large Impulsive change of the load Use special motor or motor with larger capacity than the drive Use ON/OFF controller of an electromagnetic contactor at the output (U/V/W) of the drive V/F curve setting error Torque compensation is too large Malfunction caused by interference The motor starts when in free run Improper parameter settings for the speed tracking function (including restart after momentary power loss and restart after fault) Incorrect combination of control mode and used motor The length of motor cable is too long Hardware failure Check if the setting for stall prevention is correct 	<ul style="list-style-type: none"> Increase the acceleration time. Increase the acceleration time of S curve. Set auto-acceleration and auto-deceleration parameter [ADV-06]. Set over-current stall prevention function [PROT-07]. Replace the drive with a larger capacity model. <ul style="list-style-type: none"> Check the motor cable and remove causes of the short circuits, or replace the cable before turning on the power. Check the motor insulation value with megger. Replace the motor if the insulation is poor. Check if the output current during the whole working process exceeds the AC motor drive's rated current. If yes, replace the AC motor drive with a larger capacity model. Reduce the load or increase the capacity of AC motor drive. Check the motor capacity (the rated current on the motor's nameplate should be less than rated current of the drive). Check the action timing of the contactor and make sure it is not turned ON/OFF when the drive outputs the voltage. Adjust V/F curve setting and frequency/voltage. When the fault occurs, and the frequency voltage is too high, reduce the voltage. Adjust the torque compensation (refer to [MOTOR-17]) until the output current reduces and the motor does not stall. Verify the wiring of the control circuit and wiring/grounding of the main circuit to prevent interference. Enable the speed tracking during start-up of [PROT-42]. Correct the parameter settings for speed tracking. Start the speed tracking function. Adjust the maximum current for [PROT-39] speed search tracking. <ul style="list-style-type: none"> Check the settings for [MOTOR-05]. Increase AC motor drive's capacity. Install AC reactor(s) on the output side (U/V/W). The ocA occurs due to short circuit or ground fault at the output side of the drive. Check for possible short circuits between terminals with the electric meter: B1 corresponds to U, V and W; DC corresponds to U, V and W; corresponds to U, V and W. If short circuit occur, call Technical Support. Set the stall prevention to the proper value.
occ (5) Short Circuit	<ul style="list-style-type: none"> IGBT Error Short-circuit detecting circuit error 	<ul style="list-style-type: none"> Check the motor wiring. Cycle the power, if occ still exists, contact technical support.

CONTROLS MAINTENANCE
Cerus X-Drive Maintenance

Table 90 (continued)

Fault Display	Possible Cause	Corrective Action
<p>ocd (2) Oc at decel</p>	<ul style="list-style-type: none"> • Deceleration time too short • Check if the mechanical brake of the motor activates too early • Short-circuit at motor output due to poor insulation wiring • Check for possible burnout or aging insulation of the motor • The load is too large • Impulsive change of the load • Use special motor or motor with larger capacity than the drive • Use ON/OFF controller of an electromagnetic contactor at the output (U/V/W) of the drive • V/F curve setting error • Torque compensation is too large • Malfunction caused by interference • The length of motor cable is too long • Hardware error • Check if the setting of stall prevention is correct 	<ul style="list-style-type: none"> • Increase the deceleration time. • Increase the deceleration time of S-curve. • Set auto-acceleration and auto-deceleration parameter [ADV-06]. • Set over-current stall prevention function [PROT-07]. • Replace the drive with a larger capacity model. <ul style="list-style-type: none"> – Check the action timing of the mechanical brake. – Check the motor cable and remove causes of the short circuits, or replace the cable before turning on the power. – Check the motor insulation value with megger. Replace the motor if the insulation is poor. – Check if the output current during the whole working process exceeds the AC motor drive's rated current. If yes, replace the AC motor drive with a larger capacity model. – Reduce the load or increase the capacity of AC motor drive. – Check the motor capacity (the rated current on the motor's nameplate should be the rated current of the drive). – Check the action timing of the contactor and make sure it is not turned ON/OFF when the drive outputs the voltage. – Adjust V/F curve settings and frequency/voltage. When the fault occurs, and the frequency voltage is too high, reduce the voltage. – Adjust the torque compensation (refer to [MOTOR-17]) until the output current reduces and the motor does not stall. – Verify the wiring of the control circuit and wiring/grounding of the main circuit to prevent interference. – Increase AC motor drive's capacity Install AC reactor(s) on the output side (U/V/W). – The ocd occurs due to short circuit or ground fault at the output side of the drive. – Check for possible short circuits between terminals with the electric meter: B1 corresponds to U, V and W; DC- corresponds to U, V and W; Earth Ground corresponds to U, V and W. If short circuits occur, call Technical Support. – Set the stall prevention to the proper value.

Table 90 (continued)

Fault Display	Possible Cause	Corrective Action
ocn (3) oc at normal SPD	<ul style="list-style-type: none"> • Short-circuit at motor output due to poor insulation wiring • Check for possible shaft lock, burnout or aging insulation of the motor • Impulsive change of the load • Use special motor or motor with larger capacity than the drive • Use ON/OFF controller of an electromagnetic contactor at the output (U/V/W) of the drive • V/F curve setting error • Over-torque offset value too high • Torque compensation is too large • Malfunction caused by interference • The length of motor cable is too long • Hardware failure 	<ul style="list-style-type: none"> • Check the motor cable and remove causes of the short circuits, or replace the cable before turning on the power. • Troubleshoot the motor shaft lock. Check the motor insulation value with megger. Replace the motor if the insulation is poor. • Reduce the load or increase the capacity of AC motor drive. • Check motor capacity (the rated current on the motor's nameplate should be the rated current of the drive). • Check the action timing of the contactor and make sure it is not turned ON/OFF when the drive outputs the voltage. • Adjust V/F curve settings and frequency/voltage. When the fault occurs, and the frequency voltage is too high, reduce the voltage. • Adjust over-torque offset value (refer to [MOTOR-17] for torque compensation gain), until the output current is reduced and not motor stall. • Adjust the torque compensation (refer to [MOTOR-17] for torque compensation gain) until the output current reduces and the motor does not stall. • Verify the wiring of the control circuit and wiring/grounding of the main circuit to prevent interference. • Increase the AC motor drive's capacity. Install AC reactor(s) on the output side (U/V/W). • The ocn occurs due to short circuit or ground fault at the output side of the drive. Check for possible short circuit between terminals with the electric meter: B1 corresponds to U, V and W; DC- corresponds to U, V, and W; Earth Ground corresponds to U, V, and W. • If short circuits occur, call Technical Support.
OcS (6) oc at stop	<ul style="list-style-type: none"> • Malfunction caused by interference • Hardware failure 	<ul style="list-style-type: none"> • Verify the wiring of the control circuit and wiring/grounding of the main circuit to prevent interference. • Check if other error code such as cd1-cd3 occur after cycling the power. If yes, contact technical support.
oHI (16) IGBT over heat	<ul style="list-style-type: none"> • Ambient temperature too high • VFD size does not match load • Direct sunlight • Obstruction of flow 	<ul style="list-style-type: none"> • Ensure that the ambient temperature falls within the specified temperature range. • Make sure heat sink is not obstructed. Check if the fan is operating. • Check if there is enough ventilation clearance for the drive. • Reduce load. • Replace drive with a larger capacity model. • Remove from direct sunlight.
oH2 (17) Heat Sink oH	<ul style="list-style-type: none"> • Ambient temperature too high • VFD size does not match load • Unstable power 	<ul style="list-style-type: none"> • Ensure that the ambient temperature falls within the specified temperature range. • Make sure heat sink is not obstructed. Check if the fan is operating. • Check if there is enough ventilation clearance for the drive.

CONTROLS MAINTENANCE
Cerus X-Drive Maintenance

Table 90 (continued)

Fault Display	Possible Cause	Corrective Action
<p>oH3 (24) Motor over heat</p>	<ul style="list-style-type: none"> • Motor shaft lock • The load is too large • Ambient temperature is too high • Motor cooling system error • Motor fan error • Operate at low-speed too long • Accel./Decel. time and working cycle are too short • V/F voltage is too high • Motor rated current does not match motor nameplate • PTC is improperly set and wired • Incorrect setting for stall prevention • Unbalanced three-phase impedance of the motor • Harmonics are too high 	<ul style="list-style-type: none"> • Remove the shaft lock. • Reduce the load and increase the motor capacity. • Change the installed place if there are heating devices in the surroundings. Install/ add cooling fan or air conditioner to lower the ambient temperature. • Check the cooling system to make it work normally. • Replace the fan. • Decrease low-speed operation time. Replace the motor with a dedicated to VFD model. Increase the motor capacity. • Increase the setting values for accel./decel. time. • Adjust settings for V/F curve, especially the setting value for the mid-point voltage (if the mid-point voltage is set too low, the load capacity decreases at low speed). • Reset to the correct motor rated current. • Check the connection between PTC thermistor and the heat protection. • Set the stall prevention to the proper value. • Replace the motor. • Use remedies like filters to reduce harmonics.
<p>oL (21) Overload</p>	<ul style="list-style-type: none"> • Motor and/or pump misalignment • Dragging motor and/or pump • Motor and/or pump locked • Abrasives in pump • Excess motor cable length 	<ul style="list-style-type: none"> • Amperage is above MAX AMPS at minimum frequency. • Remove and repair or replace as required. • Reduce motor cable length. Adhere to Maximum Motor Cable Length table. • For FE MagForce application, verify motor model selection, pump load, and max amps.
<p>OL-2 (27) Overload 2</p>	<ul style="list-style-type: none"> • Motor and/or pump misalignment • Dragging motor and/or pump • Motor and/or pump locked • Abrasives in pump • Excess motor cable length 	<ul style="list-style-type: none"> • Amperage is above MAX AMPS at minimum frequency. • Remove and repair or replace as required. • Reduce motor cable length. Adhere to Maximum Motor Cable Length table. • For FE MagForce application, verify motor model selection, pump load, and max amps.
<p>oL3 (87) Derating Error</p>	<ul style="list-style-type: none"> • Drive is too small for application • Ambient temperature is too high • Motor parameters incorrect 	<ul style="list-style-type: none"> • Check heat dissipation of drive location • Check all motor parameter settings • Lower the Carrier Frequency [SET-62]
<p>OPHL (82) U phase lacked OPHL (83) V phase lacked OPHL (84) W phase lacked</p>	<ul style="list-style-type: none"> • The three-phase impedance of motor is unbalanced • The motor is wired incorrectly • Damaged motor cable • Using a single-phase motor • The current sensor is damaged • The drive capacity is much larger than the motor capacity 	<ul style="list-style-type: none"> • Replace the motor. • Check motor wiring. • Check the motor cable condition and replace if needed. • Choose a three-phase motor. • Check the flat cable of the control board. Re-do the wiring and test again if the flat cable is loose. If the fault still exists, call Technical Support. Verify that the three-phase current is balanced via a current clamp meter. If it is balanced and the OPHL fault still exists, call Technical Support. • Make sure the capacity of the drive and motor match to each other.
<p>OPRS (174) Overpressure (M)</p>	<ul style="list-style-type: none"> • System pressure is too high • Nuisance tripping • Trips when system is at a low pressure • Trips at wrong level 	<ul style="list-style-type: none"> • Check for closed valves in system. • Increase analog input filter ([10-04], [10-09], or [10-10]). • Check wiring and voltage to sensor. Confirm pressure reading from keypad display to secondary gauge. • Check [SET-19] units, PID F/B Max [SET-20], and Over-Press Level [SET-40].

Table 90 (continued)

Fault Display	Possible Cause	Corrective Action
OrP (15) Phase lacked	<ul style="list-style-type: none"> • Phase loss of input power • Single phase power input to three-phase model • Power voltage changes • Loose wiring terminal of input power • The input cable of three-phase power is cut off • Input power voltage changes too much • Unbalanced three-phase of input power 	<ul style="list-style-type: none"> • Correctly install the wiring of the main circuit power. • Choose the model whose power matches the voltage. • If the main circuit power works normally, verify the main circuit. Cycle the power after checking the power, if OrP error still exists, call Technical Support. • Tighten the terminal screws according to the torque described in the user manual. • Wire correctly. Replace the cut off cable. • Verify the setting value for IPO Check Time [PROT-26] and IPO Ripple [PROT-27]. • Check the power three-phase status.
oSL (63) Over slip error	<ul style="list-style-type: none"> • Any of the motor parameters may be incorrect • Overload • Improper setup of feature 	<ul style="list-style-type: none"> • Verify the motor parameters. • Decrease the load. • Verify the settings of [MOTOR-18] through [MOTOR-21].
ovA (7) ov at accel	<ul style="list-style-type: none"> • Acceleration is too slow • The setting for stall prevention level is smaller than no-load current • Power voltage is too high • ON/OFF switch action of phase-in capacitor in the same power system • Regenerative voltage of motor inertia • Acceleration time is too short • Motor ground fault • Incorrect wiring of brake resistor or brake unit • Malfunction caused by interference 	<ul style="list-style-type: none"> • Decrease the acceleration time. Use brake unit or DC bus. Replace the drive with a larger capacity model. • The setting for stall prevention level should be larger than no-load current. • Check if the input voltage is within the rated AC motor drive input voltage range, and check for possible voltage spikes. • If the phase-in capacitor or active power supply unit acts in the same power system, the input voltage may surge abnormally in a short time. In this case, install an AC reactor. • Use over-voltage stall prevention function [PROT-04]. Use auto-acceleration and auto-deceleration setting [ADV-06]. Use a brake unit or DC bus. • Check if the over-voltage warning occurs after acceleration stops. When the warning occurs, do the following: <ul style="list-style-type: none"> – Increase the acceleration time – Set [PROT-04] for over-voltage stall prevention – Increase setting value for [VFD-26] S-curve acceleration arrival time 2 • The ground short circuit current charges the capacitor in the main circuit through the power. Check if there is ground fault on the motor cable, wiring box and its internal terminals. Troubleshoot the ground fault. • Check the wiring of brake resistor and brake unit. • Verify the wiring of the control circuit and wiring/grounding of the main circuit to prevent interference.

CONTROLS MAINTENANCE
Cerus X-Drive Maintenance

Table 90 (continued)

Fault Display	Possible Cause	Corrective Action
<p>ovd (8) ov at decel</p>	<ul style="list-style-type: none"> • Deceleration time is too short, causing too large regenerative energy of the load • The setting for stall prevention level is smaller than no-load current • Power voltage is too high • ON/OFF switch action of phase-in capacitor in the same power system • Motor ground fault • Incorrect wiring of brake resistor or brake unit • Malfunction caused by interference 	<ul style="list-style-type: none"> • Increase the setting value of [SET-12], [VFD-22], [VFD-24], and [SET-55] (deceleration time). • Connect brake resistor, brake unit or DC bus on the drive. • Reduce the brake frequency. • Replace the drive with a larger capacity model. • Use S-curve acceleration/deceleration. • Use over-voltage stall prevention [PROT-04]. • Use auto-acceleration and auto-deceleration [ADV-06]. • Adjust braking level [VFD-37] or the bolt position of the brake unit. <ul style="list-style-type: none"> – The setting for stall prevention level should be larger than no-load current. – Check if the input voltage is within the rated AC motor drive input voltage range, and check for possible voltage spikes. – If the phase-in capacitor or active power supply unit acts in the same power system, the input voltage may surge abnormally in a short time. In this case, install an AC reactor. – The ground short circuit current charges the capacitor in the main circuit through the power. Check if there is ground fault on the motor cable, wiring box and its internal terminals. Troubleshoot the ground fault. – Check the wiring of brake resistor or brake unit. – Verify the wiring of the control circuit and wiring/grounding of the main circuit to prevent interference.
<p>ovn (9) ov at normal SPD</p>	<ul style="list-style-type: none"> • Impulsive change of the load • The setting for stall prevention level is smaller than no-load current • Regenerative voltage of motor inertia • Power voltage is too high • ON/OFF switch action of phase-in capacitor in the same power system • Motor ground fault • Incorrect wiring of brake resistor or brake unit • Malfunction caused by interference 	<ul style="list-style-type: none"> • Connect brake resistor, brake unit or DC bus to the drive. • Reduce the load. • Replace to drive with a larger capacity model. • Adjust braking level [VFD-37] or bolt position of the brake unit. <ul style="list-style-type: none"> – The setting of stall prevention level should be larger than no-load current. – Use over-voltage stall prevention function [PROT-04]. Use a brake unit or DC bus. – Check if the input voltage is within the rated AC motor drive input voltage range, and check for possible voltage spikes. – If the phase-in capacitor or active power supply unit acts in the same power system, the input voltage may surge abnormally in a short time. In this case, install an AC reactor. – The ground short-circuit current charges the capacitor in the main circuit through the power. Check if there is ground fault on the motor cable, wiring box and its internal terminals. Troubleshoot the ground fault. – Check the wiring of brake resistor or brake unit. – Verify the wiring of the control circuit and wiring/grounding of the main circuit to prevent interference.

Table 90 (continued)

Fault Display	Possible Cause	Corrective Action
ovS (10) ov at stop	<ul style="list-style-type: none"> Power voltage is too high ON/OFF switch action of phase-in capacitor in the same power system Incorrect wiring of brake resistor or brake unit Malfunction caused by interference Hardware failure in voltage detection Motor ground fault 	<ul style="list-style-type: none"> Check if the input voltage is within the rated AC motor drive input voltage range, and check for possible voltage spikes. If the phase-in capacitor or active power supply unit activates in the same power system, the input voltage may surge abnormally in a short time. In this case, install an AC reactor. Check the wiring of brake resistor or brake unit. Verify the wiring of the control circuit and wiring/grounding of the main circuit to prevent interference. Check if other error code such as cd1-cd3 occur after cycling the power. If yes, return to the factory for repair. The ground short circuit current charges the capacitor in the main circuit through the power. Check if there is ground fault on the motor cable, wiring box and its internal terminals. Troubleshoot the ground fault.
Pcod (52) Password error	<ul style="list-style-type: none"> Incorrect password input through [ADV-02] 	<ul style="list-style-type: none"> Input the correct password after rebooting the motor drive. If you forget the password, input 9999 and press ENTER twice within 10 seconds. If more than 10 seconds passes, try again. The parameter settings will return to the default when the "Input 9999" process is finished.
PILF (187) Pipe Leak Fault	<ul style="list-style-type: none"> Leak in pipe after pressure sensor System is low flow causing long delay to reach wakeup level 	<ul style="list-style-type: none"> Pressurize pipe and then check for leaks Increase wake times [ADV2-48] through [ADV2-51]. Run system between different load demands and record Last Wake Time [ADV2-47] for each run. Set wake times larger than recorded value.
RoPd (89) Rotor Pos. Error	<ul style="list-style-type: none"> Motor cable is abnormal or broken Motor coil error Hardware failure Drive's current feedback line error 	<ul style="list-style-type: none"> Check cable and replace as needed. Replace motor. IGBT broken. Call Technical Support. Cycle the power. If RoPd still occurs during operation, call Technical Support.
ryF (64) MC Fault	<ul style="list-style-type: none"> The input power is abnormal Malfunction caused by interference Hardware failure 	<ul style="list-style-type: none"> Check if the power is shut down during the drive operation. Check if the three-phase input power is normal. Verify the wiring/grounding of the main circuit to prevent interference. Cycle the power after checking the power. If ryF error still exists, call Technical support.
S1 (73) S1-emergency stop	<ul style="list-style-type: none"> The switch action of S1 and SCM (OPEN) S1 and SCM short circuit lines are not connected Malfunction caused by interference Hardware failure Poor connection of the IO card The IO card does not match the version of the control board 	<ul style="list-style-type: none"> Reset the switch and cycle the power. Re-connect the short circuit lines. Verify the wiring/grounding of the main circuit, control circuit and encoder to prevent interference. If S1 fault still exists after cycling the power, please return to the factory for repair. Check if the PIN of IO card is broken. Check if the IO card connects to the control board correctly, and if the screws are tightened well. For incorrect version, contact Technical Support.
Sflk (112) PMLess ShaftLock	<ul style="list-style-type: none"> Improper setting of the speed observer bandwidth Motor shaft lock Motor error (e.g. demagnetization) 	<ul style="list-style-type: none"> Increase the setting value. Remove causes of the motor shaft lock. Replace the motor with a new one.
SHDN (179) Shutdown	<ul style="list-style-type: none"> External device activating shutdown Nuisance tripping External shutdown switch is Normally Closed circuit (no shutdown with switch closed) 	<ul style="list-style-type: none"> Reset external device causing shutdown Adjust DI filter [IO-20] Set MI to NC with DI NO/NC [IO-46]
STL1 (72) STO Loss 1 STL2 (77) STO Loss 2 STL3 (78) STO Loss 3	<ul style="list-style-type: none"> Short circuit lines are not connected Hardware failure Bad connection of the IO card The IO card does not match the version of the control board 	<ul style="list-style-type: none"> Connect the short circuit line. After you make sure all the wiring is correct, if fault still exists after cycling the power, please return to the factory for repair. Check if the PIN of IO card is broken. Check if the IO card connects to the control board correctly, and if the screws are tightened well. For incorrect version, contact Technical Support.

CONTROLS MAINTENANCE
Cerus X-Drive Maintenance

Table 90 (continued)

Fault Display	Possible Cause	Corrective Action
STO (76) STO	<ul style="list-style-type: none"> The switch action of STO1/SCM1 and STO2/SCM2 (OPEN) Poor connection of the IO card The IO card does not match the version of the control board 	<ul style="list-style-type: none"> Reset the switch (ON) and cycle the power. Check if the PIN of IO card is broken. Check if the IO card connects to the control board correctly, and if the screws are tightened well. For incorrect version, contact Technical Support.
tH1o (18) Thermo 1 open tH2o (19) Thermo 2 open	<ul style="list-style-type: none"> Hardware failure 	<ul style="list-style-type: none"> Wait for 10 minutes, and then cycle the power. If fault still exists, call Technical Support.
TPAI (182) Trip by AI	<ul style="list-style-type: none"> Trigger source has reached threshold Nuisance tripping Fault reset too quickly Fault does not reset Cannot adjust settings to correct value 	<ul style="list-style-type: none"> Adjust trigger source to acceptable value. Increase the filter time on analog input signal with [IO-04], [IO-09], or [IO-10]. Increase the Trigger Hysteresis [ADV2-66]. Increase the Trigger Hysteresis [ADV2-66]. Check settings [ADV2-62] through [ADV2-66]. If using Trigger Source [ADV2-63] = 0_FIB F/B (PID Feedback), compare Trigger Level [ADV2-65] to PID Setpoint to make sure operation is as intended. If using Trigger Source [ADV2-63] = 1_Aux AI, check Aux AI setup with parameters [ADV2-58] through [ADV2-61].
TRAP (93) CPU Trap 0 error	<ul style="list-style-type: none"> Hardware failure EMI Interference CPU in infinite loop 	<ul style="list-style-type: none"> Check wiring and grounding for possible interference If error cannot be reset, please call Technical Support
ULD (175) Underload (M)	<ul style="list-style-type: none"> Over-pumped well Broken shaft or coupling Blocked screen, worn pump Air/gas locked pump X-Drive not set properly for pump end Underload Sensitivity setting incorrect 	<ul style="list-style-type: none"> Frequency near maximum with load less than ULD Level [SET-42]. System is drawing down to pump inlet (out of water). High static, light loading pump - reset ULD Level [SET-42] if not out of water. Check pump rotation, reconnect if necessary for proper rotation. Air/gas locked pump - if possible, set deeper in well to reduce. Verify Motor FLA [SET-03] (SFA) setting is correct. For FE MagForce application, make sure [SET-03] matches pump load's rated current.
WDTT (71) Watchdog	<ul style="list-style-type: none"> Hardware interference 	<ul style="list-style-type: none"> Verify the wiring of the control circuit and wiring/grounding of the main circuit to prevent interference. If the WDTT fault still exists, please call Technical Support.

Diagnostic Warning Codes

NOTE: For more details, please refer to the X-Drive Owner's Manual.

Table 91.

Warning Display	Possible Cause	Corrective Action
ACILoss (12) AVILoss (138) Analog Loss	<ul style="list-style-type: none"> Loose or broken connection Sensor failure Drive failure 	<ul style="list-style-type: none"> Check the ACI wiring. Check if the ACI signal is less than 4mA (2V).
ApDx (127) App Disconnected	<ul style="list-style-type: none"> App has disconnected from VFD Phone is out of range from VFD Phone stopped transmitting Bluetooth 	<ul style="list-style-type: none"> Open app and reselect VFD from 'My Products' page. Move phone closer to VFD especially if VFD is within metal enclosure. Check phone's Bluetooth settings. FE BT Option card will not be listed in the phone's Bluetooth device pairing list.
BTFW (126) BT FW Incompat	<ul style="list-style-type: none"> VFD firmware not at least version 1.2 Improper communication 	<ul style="list-style-type: none"> Replace or update VFD with at least 1.2 firmware Check card installation
CAdn (41) CAN/S Address	<ul style="list-style-type: none"> Incorrect setting of CANOpen station address 	<ul style="list-style-type: none"> Disable CANOpen Reset CANOpen ([SET-07] = 7) Reset CANOpen station address
CbFn (39) CAN/S Bus Off	<ul style="list-style-type: none"> Check if the CANOpen card is installed Check if the CANOpen speed is correct Malfunction caused by interference Communication cable is broken or bad connected 	<ul style="list-style-type: none"> Make sure the CANOpen card is installed. Reset CANOpen speed For interference: <ul style="list-style-type: none"> Verify the wiring and grounding of the communication circuit. It is recommended to separate the communication circuit from the main circuit, or wire in 90 degree for effective anti-interference performance. Make sure the communication circuit is wired in series. Use CANOpen cable or add terminating resistance. Check or replace the communication cable.
CE1 (1) Comm. Error 1 CE2 (2) Comm. Error 2 CE3 (3) Comm. Error 3 CE4 (4) Comm. Error 4	<ul style="list-style-type: none"> Incorrect communication command from upper unit Malfunction caused by interference Different communication setting from the upper unit Disconnection or bad connection of the cable 	<ul style="list-style-type: none"> Check if the communication command is correct. Verify the wiring and grounding of the communication circuit. It is recommended to separate the communication circuit from the main circuit, or wire in 90 degree for effective anti-interference performance. Check if the setting for [Comm-02] is the same as the setting for the upper unit. Check the cable and replace it if necessary.
CE10 (5) Comm. Error 10	<ul style="list-style-type: none"> The upper unit does not transmit the communication command within [Comm-03] setting time Malfunction caused by interference Different communication setting from the upper unit Disconnection or bad connection of the cable 	<ul style="list-style-type: none"> Check if the upper unit transmits the communication command within the setting time for [Comm-03]. Verify the wiring and grounding of the communication circuit. It is recommended to separate the communication circuit from the main circuit, or wire in 90 degree for effective anti-interference performance. Check if the setting for [Comm-02] is the same as the setting for the upper unit. Check the cable and replace it if necessary.
CFrn (42) CAN/S FRAM fail	<ul style="list-style-type: none"> CANOpen internal memory error 	<ul style="list-style-type: none"> Disable CANOpen Reset CANOpen ([SET-07] = 7) Reset CANOpen station address
CGdn (36) Guarding T-out	<ul style="list-style-type: none"> The guarding time is too short, or less detection times Malfunction caused by interference 	<ul style="list-style-type: none"> Increase the guarding time (Index 100C) and detection times. Verify the wiring and grounding of the communication circuit. It is recommended to separate the communication circuit from the main circuit, or wire in 90 degree for effective anti-interference performance. Make sure the communication circuit is wired in series. Use CANOpen cable or add terminating resistance.

CONTROLS MAINTENANCE
Cerus X-Drive Maintenance

Table 91 (continued)

Warning Display	Possible Cause	Corrective Action
CHbn (37) Heartbeat T-out	<ul style="list-style-type: none"> The heartbeat time is too short Malfunction caused by interference Communication cable is broken or bad connection 	<ul style="list-style-type: none"> Increase heartbeat time (Index 1016) Verify the wiring and grounding of the communication circuit. It is recommended to separate the communication circuit from the main circuit, or wire in 90 degree for effective anti-interference performance. Make sure the communication circuit is wired in series. Use CANopen cable or add terminating resistance. Check or replace the communication cable.
CIdn (40) CAN/S Idx exceed	<ul style="list-style-type: none"> Incorrect setting of CANopen index 	<ul style="list-style-type: none"> Reset CANopen Index ([ADV-03] = 7)
CPL0 (91) Copy PLC Mode Rd CPL1 (92) Copy PLC Mode Wt	<ul style="list-style-type: none"> When copy PLC mode and the process is incorrect 	<ul style="list-style-type: none"> Cycle the power and copy PLC mode again
CPLF (95) Copy PLC Func	<ul style="list-style-type: none"> PLC function is enabled when KPCCC01 is running copy PLC 	<ul style="list-style-type: none"> Disable PLC function first, then run the PLC copy function again
CPLP (90) Copy PLC Pass Wd	<ul style="list-style-type: none"> PLC password is incorrect 	<ul style="list-style-type: none"> Reset and enter correct PLC password
CPLS (94) Copy PLC Pass Size	<ul style="list-style-type: none"> The PLC copied to the drive exceeds the allowable capacity 	<ul style="list-style-type: none"> Check if the copied PLC program is for the drive Use drive PLC program with correct capacity
CPLt (96) Copy PLC TimeOut	<ul style="list-style-type: none"> KPC-CC01 is removed while copying PLC program 	<ul style="list-style-type: none"> The KPC-CC01 cannot be removed during the PLC copy process
CPLv (93) Copy PLC Version	<ul style="list-style-type: none"> Incompatible PLC program is copied to the drive 	<ul style="list-style-type: none"> Check if the copied PLC program is for the X-Drive. Use the correct PLC program.
CPtn (46) CAN/S protocol	<ul style="list-style-type: none"> The upper unit sends incorrect communication packet 	<ul style="list-style-type: none"> Make sure the master sends the packet based on CANopen DS301 standard command format.
CSbn (44) CAN/S Buf over	<ul style="list-style-type: none"> Too much SDO from the upper unit 	<ul style="list-style-type: none"> Check if the master sends too much SDO command. Make sure the master sends SDO command according to the command format.
CSdn (43) CAN/S SDO T-out	<ul style="list-style-type: none"> Follower is not connected The synchronize cycle is set too short Malfunction caused by interference Disconnection or bad connection of the communication cable 	<ul style="list-style-type: none"> Connect follower and CANopen BUS. Increase the synchronization time For interference: <ul style="list-style-type: none"> Verify the wiring and grounding of the communication circuit. It is recommended to separate the communication circuit from the main circuit, or wire in 90 degree for effective anti-interference performance. Make sure the communication circuit is wired in series. Use CANopen cable or add terminating resistance. Check the status of the cable, or replace the cable.
dAvE (18) Deviation Warn	<ul style="list-style-type: none"> Improper parameter setting for the slip error Improper setting for ASR parameter and acceleration/ deceleration Accel./ Decel. time is too short Motor locked Incorrect parameter setting of torque limit Malfunction caused by interference 	<ul style="list-style-type: none"> Reset ASR parameters. Then set proper accel./ decel. time. Reset proper accel./ decel. time. Remove the causes of motor locked. Check the active timing of the system. Adjust to proper setting value. Verify wiring of the control circuit, and wiring/grounding of the main circuit to prevent interference.
dEb (123) Dec. Energy back	<ul style="list-style-type: none"> Instantaneous power off or low voltage and unstable/ sudden heavy load of the power that cause the voltage drop Unexpected power off 	<ul style="list-style-type: none"> Check the power consumption
EC3F (87) ExCom Mail fail	<ul style="list-style-type: none"> Communication card establishes alarm conditions 	<ul style="list-style-type: none"> No actions necessary
ECbF (73) ExCom Bus off	<ul style="list-style-type: none"> Poor connection of the cable Bad quality of the cable 	<ul style="list-style-type: none"> Re-connect the cable. Replace the cable.
ECbY (88) ExCom Busy	<ul style="list-style-type: none"> Communication packets are too much for the communication card to process 	<ul style="list-style-type: none"> Reduce communication packets.
ECCb (89) ExCom Card break	<ul style="list-style-type: none"> Communication card break off 	<ul style="list-style-type: none"> Re-install communication card
ECCFF (75) ExCom Factly def	<ul style="list-style-type: none"> Factory default setting error 	<ul style="list-style-type: none"> Use DCISoft to reset to the default value.

Table 91 (continued)

Warning Display	Possible Cause	Corrective Action
ECSS (82) ExCom Inr CRC	<ul style="list-style-type: none"> Noise interference 	<ul style="list-style-type: none"> Verify wiring of the control circuit, and wiring/grounding of the main circuit to prevent interference.
ECEF (80) ExCom Link Fail	<ul style="list-style-type: none"> Ethernet cable is loose Bad quality of Ethernet cable 	<ul style="list-style-type: none"> Re-connect the cable Replace the cable
ECId (70) ExCom ID failed	<ul style="list-style-type: none"> The setting address exceeds the range (0-63) The speed setting exceeds the range The address is duplicated with other nodes on the BUS 	<ul style="list-style-type: none"> Check the address setting of the communication card [Comm-34] Standard: 0-2; Non-standard: 0-7 Reset the address
ECiF (76) ExCom Inner err	<ul style="list-style-type: none"> Noise interference The memory is broken 	<ul style="list-style-type: none"> Verify wiring of the control circuit, and wiring/grounding of the main circuit to prevent interference. Cycle the power. Reset to the default value and check if the error still exists. If yes, replace the communication card.
ECio (77) ExCom IONet brk	<ul style="list-style-type: none"> The cable is loose Incorrect parameter setting for master communication 	<ul style="list-style-type: none"> Re-install the cable Check the setting for master communication parameter
ECiP (86) ExCom IP fail	<ul style="list-style-type: none"> IP conflict DHCP IP configuration error 	<ul style="list-style-type: none"> Reset IP MIS check if DHCP Server works normally
ECLv (71) ExCom pwr loss	<ul style="list-style-type: none"> The card is loose The 5V power that drive provides to communication card is to low 	<ul style="list-style-type: none"> Make sure the communication card is well inserted. If 5v power is too low: <ul style="list-style-type: none"> Switch the communication card to other X-Drives and observe if there is ECLv warning shown. If yes, replace with a new communication card; if not, replace the drive. Use another communication card to test if the ECLv warning has shown as well. If not, replace the card; if yes, replace the drive.
ECnP (74) ExCom No power	<ul style="list-style-type: none"> The drive detects that DeviceNet has no power 	<ul style="list-style-type: none"> Check if the cable and power is normal. If yes, return to the factory for repair.
ECo0 (84) ExCom MTCp over	<ul style="list-style-type: none"> The Master communication value is more than the allowable quantity of the communication card The upper unit is online without communicating, and does not break off the Modbus TCP link, causes occupy connection A new Modbus TCP connection is built every time when the upper unit is connected to the communication card, which caused occupy connection 	<ul style="list-style-type: none"> Reduce Master communication value Revise program of upper unit, the communication should be break off when it is not used for a long time Revise program of upper unit: use the same Modbus TCP connection when connected to the same communication card
ECo1 (85) ExCom EIP over	<ul style="list-style-type: none"> The Master communication value is more than the allowable quantity of the communication card The upper unit is online without communicating, and does not break off the Modbus TCP link, causes occupy connection A new Modbus TCP connection is built every time when the upper unit is connected to the communication card, which caused occupy connection 	<ul style="list-style-type: none"> Reduce Master communication value Revise program of upper unit, the communication should be break off when it is not used for a long time Revise program of upper unit: use the same Modbus TCP connection when connected to the same communication card
ECPi (79) ExCom Conf data	<ul style="list-style-type: none"> The GSD file is incorrect 	<ul style="list-style-type: none"> Get the correct GSD file from the software.
ECPP (78) ExCom Pr data	<ul style="list-style-type: none"> The GSD file is incorrect 	<ul style="list-style-type: none"> Get the correct GSD file from the software
ECrF (83) ExCom Rtn def	<ul style="list-style-type: none"> Communication card is returning to default setting 	<ul style="list-style-type: none"> No actions necessary
ECto (81) ExCom Intr T-out	<ul style="list-style-type: none"> Communication card is not connected with the upper unit Communication error of the upper unit 	<ul style="list-style-type: none"> Check if the connection of the communication cable is correct Check if the communication of the upper unit is normal
ECtt (72) ExCom Test Mode	<ul style="list-style-type: none"> Communication command error 	<ul style="list-style-type: none"> Cycle the power

CONTROLS MAINTENANCE
Cerus X-Drive Maintenance

Table 91 (continued)

Warning Display	Possible Cause	Corrective Action
ictn (101) InrCOM Time Out	<ul style="list-style-type: none"> Malfunction caused by interference Different communication conditions with the upper unit Communication cable break off or not connected well 	<ul style="list-style-type: none"> Verify wiring/grounding of the communication circuit. It is recommended to separate the communication circuit from the main circuit, or wire in 90 degree for effective anti-interference performance. Check if the setting for [Comm-02] is the same as the setting for upper unit Check the cable status or replace the cable
LBLV (128) Limit by Level	<ul style="list-style-type: none"> Aux AI signal is changing Max Freq changing too quickly with change of Aux AI 	<ul style="list-style-type: none"> Review system monitoring. Set Limit by Level [IO-16] to 0_Disable. Decrease Min Limit Level [IO-18] or increase Min Freq Limit [IO-19].
MVNC (131) M-VFD No Commu	<ul style="list-style-type: none"> Communication line broken Multiple VFDs with the same Multi-VFD ID [ADV-37] 	<ul style="list-style-type: none"> Check wiring between drives and replace as needed. Check Multi-VFD ID [ADV-37] on each drive to make sure each drive has a unique value and that it is less than Multi-VFD Set [ADV-35].
oH1 (9) Over heat 1 Warn	<ul style="list-style-type: none"> Ambient temperature or temperature inside the cabinet is too high, or there is obstruction in the ventilation hole of the control cabinet Check if there is any obstruction on the heat sink or if the fan is running Insufficient ventilation space Check if the drive matches the corresponded loading The drive has run 100% or more of the rated output for a long time 	<ul style="list-style-type: none"> Check the ambient temperature. Regularly inspect the ventilation hole of the control cabinet. Change the installed place if there are heating objects, such as braking resistors, in the surroundings. Install/ add cooling fan or air conditioner to lower the temperature inside the cabinet. Remove the obstruction or replace the cooling fan. Increase ventilation space of the drive. Decrease loading. Decrease the carrier. Replace with a drive with larger capacity. Replace with a drive with larger capacity.
oH2 (10) Over heat 2 Warn	<ul style="list-style-type: none"> Ambient temperature or temperature inside the cabinet is too high, or there is obstruction in the ventilation hole of the control cabinet Check if there is any obstruction on the heat sink or if the fan is running Insufficient ventilation space Check if the drive matches the corresponded loading 	<ul style="list-style-type: none"> Check the ambient temperature. Regularly inspect the ventilation hole of the control cabinet. Change the installed place if there are heating objects, such as braking resistors, in the surroundings. Install/ add cooling fan or air conditioner to lower the temperature inside the cabinet. Remove the obstruction or replace the cooling fan. Increase ventilation space of the drive. Decrease loading. Decrease the carrier. Replace with a drive with larger capacity.
oH3 (22) Motor Over Heat	<ul style="list-style-type: none"> Motor locked The load is too large Ambient temperature is too high Motor cooling system error Motor fan error Operates at low-speed too long Accel./ Decel. time and working cycle is too short V/F voltage is too high Check if the motor rated current matches the motor nameplate Check if the PTC/PT100 is properly set and wired Check if the setting for stall prevention is correct Unbalance three-phase impedance of the motor Harmonics is too high 	<ul style="list-style-type: none"> Clear the motor lock status. Decrease the loading. Replace with a motor with larger capacity. Change the installed place if there are heating devices in the surroundings. Install/ add cooling fan or air conditioner to lower the ambient temperature. Check the cooling system to make it work normally. Replace the fan. Decrease low-speed operation time. Change to dedicated motor for the drive. Increase the motor capacity. Increase setting values for [SET-12] and [SET-13]. Adjust settings for [VFD-02] (V/F curve), especially the setting value for the mid-point voltage (if the mid-point voltage is set too small, the load capacity decreases at low-speed). Configure the correct rated current value of the motor again. Check the connection between PTC/PT100 thermistor resistor and the heat protection. Set the stall prevention to the proper value. Replace the motor. Use remedies to reduce harmonics.

Table 91 (continued)

Warning Display	Possible Cause	Corrective Action
OL-2 (21) OL-2	<ul style="list-style-type: none"> Incorrect parameter setting Mechanical error (e.g. mechanical lock due to over-torque) The load is too large Accel./ Decel. time and working cycle is too short V/F voltage is too high The motor capacity is too small Over-load during low-speed operation The torque compensation is too large Improper parameter settings for the speed tracking function (including restart after momentary power loss and restart after fault) 	<ul style="list-style-type: none"> Configure the settings for [PROT-13] and [PROT-14] Remove the causes of malfunction. Decrease the loading. Replace with a motor with larger capacity. Increase the setting values for [SET-11] and [SET-12] Adjust the V/F curve (Motor 2, [VFD-03]), especially the setting value for the mid-point voltage (if the mid-point voltage is set too small, the load capacity decreases at low-speed). Replace with a motor with larger capacity. Decrease the loading during low-speed operation. Increase the motor capacity. Adjust the torque compensation value ([Motor-17]) until the output current decreases and the motor does not stall. Correct the parameter settings for speed tracking. Start speed tracking function. Adjust the maximum current for [PROT-39] speed tracking.
OPHL (28) Output PHL Warn	<ul style="list-style-type: none"> Unbalanced three-phase impedance of the motor Check if the wiring is incorrect Check if the motor is a single-phase motor Check if the current sensor is broken If capacity of the drive is larger than the motor 	<ul style="list-style-type: none"> Replace the motor. Check the cable. Replace the cable. Choose a three-phase motor. Check if the control board cable is loose. If yes, reconnect the cable and run the drive to test. If the error still occurs, return to the factory for repair. Check if the three-phase current is balanced with a current clamp meter. If the current is balanced and the OPHL error still shows on the display, return to the factory for repair. Choose the matches capacity of the drive and motor.
oSL (24) Over Slip Warn	<ul style="list-style-type: none"> Motor parameter is incorrect Load is too large Check if the settings for [Motor-19] and [Motor-20] are properly set 	<ul style="list-style-type: none"> Check the motor parameter. Decrease the loading. Check the parameter settings for oSL protection.
oSPD (17) Over Speed Warn	<ul style="list-style-type: none"> Improper setting for FOC bandwidth of speed observer Improper bandwidth setting for ASR speed controller Incorrect motor parameter setting Malfunction caused by interference 	<ul style="list-style-type: none"> Decrease setting value for FOC bandwidth of speed observer. Increase the bandwidth setting for ASR speed controller. Reset motor parameter and run parameter tuning. Verify wiring of the control circuit, and wiring/grounding of the main circuit to prevent interference.
ot1 (20) Over Torque 1	<ul style="list-style-type: none"> Incorrect parameter setting Mechanical error (e.g. mechanical lock due to over-torque) The load is too large Accel./ Decel. time and working cycle is too short V/F voltage is too high The motor capacity is too small Over-load during low-speed operation The torque compensation is too large Improper parameter settings for the speed tracking function (including restart after momentary power loss and restart after fault) 	<ul style="list-style-type: none"> Configure the settings for [SET-48] and [SET-50] again. Remove the causes of malfunction. Decrease the loading. Replace with a motor with larger capacity. Increase the setting values for [SET-11] and [SET-12] (accel./ decel. time). Adjust the settings for [VFD-02] – to be 01 to 08 (V/F curve), especially the setting value for the midpoint voltage (if the mid-point voltage is set too small, the load capacity decreases at low-speed). Replace with a motor with larger capacity. Decrease the loading during low-speed operation. Increase the motor capacity. Adjust the torque compensation value [Motor-17] until the output current decreases and the motor does not stall. Correct the parameter settings for speed tracking. Start the speed tracking function. Adjust the maximum current for [PROT-39] speed tracking.
PCAd (67) CAN/M Address	<ul style="list-style-type: none"> When the CANopen master detects an incorrect or repeated station address from the follower 	<ul style="list-style-type: none"> Set the correct follower station address.

CONTROLS MAINTENANCE
Cerus X-Drive Maintenance

Table 91 (continued)

Warning Display	Possible Cause	Corrective Action
PCbF (62) CAN/M bus off	<ul style="list-style-type: none"> Malfunction caused by interference Communication cable is broken or bad connected 	<ul style="list-style-type: none"> For interference: <ul style="list-style-type: none"> Verify wiring/grounding of the communication circuit. It is recommended to separate the communication circuit from the main circuit, or wire in 90 degree for effective anti-interference performance. Make sure the communication circuit is wired in series. Use CANopen cable or add terminating resistance. Check or replace the communication cable.
PCct (64) CAN/M Cycle Time	<ul style="list-style-type: none"> When the transmitted packet from CANopen master exceeds the maximum allowable quantity in a certain time 	<ul style="list-style-type: none"> Increase the time setting of D1090 synchronization cycle
PCGd (61) CAN/M Guard err	<ul style="list-style-type: none"> Follower is not connected or CANopen BUS cable is not connected Malfunction caused by interference Communication cable is broken or badly connected 	<ul style="list-style-type: none"> Connect the Follower and CANopen BUS For interference: <ul style="list-style-type: none"> Verify wiring/grounding of the communication circuit. It is recommended to separate the communication circuit from the main circuit, or wire in 90 degree for effective anti-interference performance. Make sure the communication circuit is wired in series. Use CANopen cable or add terminating resistance. Check or replace the communication cable.
PCnL (63) CAN/M Node Lack	<ul style="list-style-type: none"> The configured node quantity is different from the actual nodes Communication cable is broken or bad connected 	<ul style="list-style-type: none"> Connect BUS to the original follower, or change the configured node numbers to meet the actual node quantity. Check or replace the communication cable.
PCSd (66) CAN/M Sdo Tout	<ul style="list-style-type: none"> When the CANopen master transmits a SDO command, and does not receive feedback from the Follower within 1 sec. 	<ul style="list-style-type: none"> Check if the Follower responds within 1 second.
PCSF (65) CAN/M SDO over	<ul style="list-style-type: none"> Internal PLC transmits too much SDO at once 	<ul style="list-style-type: none"> The PLC program needs to confirm receiving the SDO feedback data before sending another SDO command.
PCTo (68) CAN/M T-Out	<ul style="list-style-type: none"> Malfunction caused by interference The command from the upper unit does not meet the CANopen format 	<ul style="list-style-type: none"> For interference: <ul style="list-style-type: none"> Verify wiring/grounding of the communication circuit. It is recommended to separate the communication circuit from the main circuit, or wire in 90 degree for effective anti-interference performance. Make sure the communication circuit is wired in series. Use CANopen cable or add terminating resistance. If the command does not meet the format, call Technical Support.
PHL (19) Phase Loss Warn	<ul style="list-style-type: none"> Phase loss of the input power Single phase power input on a three-phase model The power voltage has changed Loose wiring terminal of input power Check if the input cable of three-phase power is broken The voltage of input power has changed Unbalance three-phase of the input power 	<ul style="list-style-type: none"> Verify wiring of the main circuit. Use the model with voltage that matches the power. If the power of main circuit works well, check if the MC of the main circuit is broken. Cycle the power after verifying the power is normal. If PHL still occurs, return to the factory for repair. Tighten the terminal screws with the torque listed in the user manual. Check setting for IPO Check Time [PROT-26] and IPO Ripple [PROT-27]. Check the status of three-phase power.
PID (11) PID FBK Error	<ul style="list-style-type: none"> Loose or broken PID feedback wiring Feedback device malfunction Hardware error 	<ul style="list-style-type: none"> Tighten the terminals again. Replace with a new cable. Replace with a new feedback device. If the PID error still occurs after checking all the wiring, return to the factory for repair.
PILA (139) Pipe Leak Alarm	<ul style="list-style-type: none"> Leak in pipe after pressure sensor System is low flow causing long delay to reach wake-up level 	<ul style="list-style-type: none"> Pressurize pipe and then check for leaks. Increase wake times [ADV2-48] to [ADV2-51]. Run system between different load demands and record Last Wake Time [ADV2-47] for each run. Set wake times larger than recorded value.
PLCr (58) PLC MCR error	<ul style="list-style-type: none"> The MC command is continuously used for more than 9 times 	<ul style="list-style-type: none"> Check and reset the program, then re-download the program.
PLdA (52) Data defect	<ul style="list-style-type: none"> During PLC operation, the external Modbus has written/read incorrect data to internal PLC program 	<ul style="list-style-type: none"> Check if the upper unit transmits the correct command.

Table 91 (continued)

Warning Display	Possible Cause	Corrective Action
PLdF (59) Download fail	<ul style="list-style-type: none"> PLC download is forced to stop, so the program write-in is incomplete 	<ul style="list-style-type: none"> Check if there is any error in the program and re-download the PLC program
PLEd (57) No end command	<ul style="list-style-type: none"> There is no "END" command during PLC operation 	<ul style="list-style-type: none"> Disable PLC Remove PLC program ([ADV-03] = 6) Enable PLC Re-download PLC program
PLFF (55) PLFn (53) Function defect	<ul style="list-style-type: none"> The PLC runs an incorrect command during operation Unsupported command has used while downloading the program 	<ul style="list-style-type: none"> When starting the PLC function and there is no program in the PLC, the PLFF warning shows. This is a normal warning. Please download the program. Check if the firmware of the drive is the old version. If yes, contact Technical Support.
PLod (50) Opposite defect	<ul style="list-style-type: none"> Incorrect component number is found when downloading the PLC program 	<ul style="list-style-type: none"> Use the correct component number.
PLor (54) Buf overflow	<ul style="list-style-type: none"> The program detects source code error during PLC operation 	<ul style="list-style-type: none"> Disable PLC Delete PLC program ([ADV-03] = 6) Enable PLC Re-download PLC program
PLrA (47) RTC Adjust	<ul style="list-style-type: none"> When using RTC function for PLC program, and the drive is power off over 7 days or KPC-CC01 does not connect to the drive for a long time, the RTC time is different with the internal calculated time when reconnect the keypad to the drive. KPC-CC01 does not adjust the RTC time PLC detects unreasonable RTC time Replaced a KPC-CC01 	<ul style="list-style-type: none"> Stop the PLC program and restart it. Adjust the RTC time and cycle the power. Adjust the RTC time and cycle the power. Stop the PLC program and restart it. Cycle the power.
PLrT (49) Keypad RTC TOut	<ul style="list-style-type: none"> KPC-CC01 is not connected to the control board while using the RTC function 	<ul style="list-style-type: none"> Do not remove the KPC-CC01 keypad while using RTC function.
PLSF (60) Scan time fail	<ul style="list-style-type: none"> The PLC scan time exceeds the maximum allowable time (400ms) 	<ul style="list-style-type: none"> Check if the source code is correct and re-download the program.
PLSn (56) Check sum error	<ul style="list-style-type: none"> The program detects checksum error during PLC operation 	<ul style="list-style-type: none"> Disable PLC Remove PLC program ([ADV-03] = 6) Enable PLC Re-download PLC program
PLSv (51) Save mem defect	<ul style="list-style-type: none"> An incorrect written address is detected during PLC operation 	<ul style="list-style-type: none"> Make sure the write-in address is correct and re-download the program.
SE1 (7) Save Error 1	<ul style="list-style-type: none"> Communication connection error Keypad error Control board error 	<ul style="list-style-type: none"> The causes of error are mostly communication problems between the keypad and control board. Potential causes include communication signal interference and the unacceptable communication command to the Follower. Check if the error occurs randomly, or only occurs when copying certain parameters (the error displays on the upper right corner of the copy page). If you cannot clear the error, please contact Technical Support.
SE2 (8) Save Error 2	<ul style="list-style-type: none"> Add new parameters to the new firmware version Malfunction caused by interference 	<ul style="list-style-type: none"> SE2: In this stage, the copied data has been transmitted to the Follower. The Follower compares and processes the copied data, and then saves the data to the Data ROM. During the process, the data error (should be attribution error) may occur, or the data cannot be saved to EEPROM. At this time, the warning occurs. It is suggested to check the status of Data ROM and remove the error causes first. If you cannot clear the error, please contact Technical Support. Verify the wiring and grounding of the main circuit, control circuit and the encoder for effective anti-interference performance.
SE3 (30) Copy Model Err	<ul style="list-style-type: none"> Keypad copy between different power range drives 	<ul style="list-style-type: none"> It is mainly to prevent parameter copies between different HP/models.

CONTROLS MAINTENANCE
Cerus X-Drive Maintenance

Table 91 (continued)

Warning Display	Possible Cause	Corrective Action
SpdR (105) Est-Speed REV	<ul style="list-style-type: none"> The motor runs in reverse direction at start The difference between motor parameter measured Rr and Rs value is too large Insufficient output torque is dragged to the reverse direction by the load. 	<ul style="list-style-type: none"> Check if the motor is hold when started, or start the motor with speed source. Normally the Rr value of IM is $R_s \times 0.7$. If there is much difference of the measured value (e.g. $R_r = R_s \times 0.3$), proceed the motor parameter auto-tuning again. Increase the output torque.
tUn (25) Auto tuning	<ul style="list-style-type: none"> The motor parameter is running autotuning 	<ul style="list-style-type: none"> When the auto-tuning is finished, the warning automatically clears.
uC (13) Under Current	<ul style="list-style-type: none"> Broken motor cable Improper setting for the low current protection Low load 	<ul style="list-style-type: none"> Exclude the connection issue of the motor and its load. Set the proper settings for [SET-42], [SET-44] and [SET-41]. Check the loading status. Make sure the loading matches the motor capacity.
Vivd (130) VFD-N Invalid	<ul style="list-style-type: none"> Wrong parameter values for [ADV-35], [ADV-36], [SET-07], and [SET-17] Multiple masters on network 	<ul style="list-style-type: none"> Verify settings match master drive. To identify master drive, set [SET-58] to 23_Comm Role. On screen, then 0=No Role, 1=Master, and 2=Follower. If network has multiple masters, make sure each drive on network has unique Multi-VFD ID [ADV-37] and that value is equal or less than Multi-VFD Set [ADV-35]. If network has multiple masters, check communication wiring between drives and replace wiring as needed.
Vlos (129) VFD-N Lost	<ul style="list-style-type: none"> Communication line broken Multiple VFDs with the same Multi-VFD ID [ADV-37] 	<ul style="list-style-type: none"> Check wiring between drives and replace as needed. Check Multi-VFD ID [ADV-37] on each drive to make sure each drive has a unique value and that it is less than Multi-VFD Set [ADV-35].
VnAT (132) VFD HOA not Aut	<ul style="list-style-type: none"> This drive is in HAND or OFF mode This drive has Multi-drive operation enabled 	<ul style="list-style-type: none"> Use HOA Mode Source [SET-60] to change mode to AUTO. Change Multi-VFD Set [ADV-35] to 0_Single VFD to disable Multi-drive operation.

CONTROLS GLOSSARY

Term	Definition
A	Amp or amperage
AWG	American Wire Gauge
°C	Degree Celsius
CRC	Capacitor Run Control
DI	Digital Input
dV/dt	Rise Time of the Voltage
°F	Degree Fahrenheit
ft	Foot
GFCI	Ground Fault Circuit Interrupter
hp	Horsepower
Hz	Hertz
ID	Identification
IGBT	Insulated Gate Bipolar Transistor
L1, L2, L3	Line One, Line Two, Line Three
lpm	Liters per Minute
max	Maximum
NEC	National Electrical Code
NEMA	National Electrical Manufacturer Association
OL	Overload
PF	Power Factor
psi	Pounds per Square Inch
QD	Quick Disconnect
SF	Service Factor = Amps at Maximum HP Loads
V	Voltage
VAC	Voltage Alternating Current
VFD	Variable Frequency Drive
W	Watts

FORMULAS

Cable Size

Refer to [“Cable Size Combinations” on page 50.](#)

Figure 31.

$$\frac{\text{Actual Length}}{\text{Max Allowed}} + \frac{\text{Actual Length}}{\text{Max Allowed}} = 1.00$$

Cooling Flow

Refer to [“Required Cooling Flow” on page 9.](#)

Figure 32.

$\text{fps} = \frac{\text{gpm} \times .409}{\text{ID}^2 - \text{OD}^2}$	<p>fps = feet per second gpm = gallons per minute ID = internal diameter (in inches) of casing or sleeve OD = outside diameter (in inches) of the motor .409 is a constant used because of the various units of measurement (inches, feet, meters, etc.)</p>
---	--

Submersible Motor Operating Costs

Figure 33.

$$\text{kilowatt hours consumed at the motor terminals} = \frac{\# \text{ of operating hours} \times 0.746 \times \text{hp}}{\text{motor efficiency}}$$

$$\text{cost per hour of pumping} = \frac{.000189 \times \text{gpm} \times \text{head in feet} \times \text{power cost per kWh}}{\text{pump efficiency} \times \text{motor efficiency}}$$

VFD Generator Sizing / X-Drive

Figure 34.

$\text{Watts} = \text{Maximum VFD Amp Rating} \times 1.5 \times 1.732 \times \text{Motor Nameplate Voltage}$
<p>Maximum VFD Amps = nameplate max of the VFD unit. (This value will typically be higher than the motor max amps)</p> <p>1.5 (or 150%) = an industry value to provide tolerance for difference generator manufacturers and designs.</p> <p>1.732 = square root of 3 (For 1-phase generators, delete this value).</p> <p>Nameplate volts = voltage rating of the motor, not the power source (IE. 460v, not 480v).</p>

Form 2207 – Action Facts

SUBMERSIBLE MOTOR INSTALLATION RECORD

INFORMATION SUPPLEMENT

1.0 MOTOR

- 1.1 Verify motor nameplate data meets the application – hp, voltage, phase, and Hertz.
- 1.2 Check that the motor shaft rotates freely by hand on the second of two complete rotations. (On large motors, this usually requires a motor coupling with a cheater handle welded to it.)
- 1.3 Check that the motor lead assembly is not damaged.
- 1.4 Measure insulation resistance to ground at 500 VDC (1000 VDC max) with a megohmmeter or megger, before submerging. It should be a minimum of 200 megohms or 200,000,000 ohms.
- 1.5 Measure insulation resistance to ground at 500 VDC (1000 VDC max) with a megohmmeter or megger, after submerging. It should be a minimum of 0.5 megohms or 500,000 ohms.
- 1.6 Verify the system is operating within the $\pm 10\%$ of nameplate voltage requirement.
- 1.7 Verify the system will not ever operate in excess of the maximum amps indicated on the nameplate.
- 1.8 Verify the system is operating at 5% or less current unbalance.

Notice:

- If current unbalance exceeds 5%, the maximum operating amps must be derated to the nameplate Full Load Amps.
- Warning - System current unbalance can not exceed 10% without causing heating and mechanical wear issues.
- The submersible motor amperage % unbalance is typically 6x greater than its voltage % unbalance.
- Thus, 0.8% voltage unbalance = greater than 5% current unbalance, and 1.7% voltage unbalance = greater than 10% current unbalance.

2.0 PUMP

- 2.1 Verify the pump nameplate and curve data meets the application hp, rpm, and flow/TDH requirements.
- 2.2 Verify the pump NPSH requirement will be met at all times.
- 2.3 Check that the pump shaft rotates freely by hand before installation.
- 2.4 Check that the pump shaft moves up about $\frac{1}{4}$ inch when it is coupled to the motor.
- 2.5 Check that the pump guard is not pinching the motor leads, especially where it enters and exits the guard.

Notice:

- Pumps and motors 5 hp and above should be assembled in a vertical position to ensure correct alignment.
- A motor-pump assembly 5 hp and above should never be lifted from a non-vertical position by the pump discharge because it can bend the shaft in one or both of the products.

3.0 POWER SUPPLY (3-PHASE)

- 3.1 Verify the transformer kVA rating is adequate for the motor per the Franklin Application (AIM) manual requirement.
- 3.2 Verify that all transformers have the same kVA rating.
- 3.3 Verify the 3-Phase pump panel fuses or its circuit breaker are correctly sized per the Franklin Application (AIM) manual requirement.
- 3.4 Verify the 3-Phase pump panel motor contactor is correctly sized per the Franklin Application (AIM) manual requirement.
- 3.5 Verify the 3-Phase pump panel motor overload is ambient compensated.
- 3.6 Verify the 3-Phase pump panel motor overload has a NEMA Class 10 trip curve.
- 3.7 Verify the 3-Phase pump panel motor overload heaters or its dial setting are correctly selected based on the system's operating point and not just arbitrarily set at the maximum motor operating amps.
- 3.8 At no time should the system operating amps or the motor overload system running point setting be higher than the motor nameplate maximum amp rating.

Notice:

- Electronic overloads should be set at the normal system operation point.
- Electronic overloads have a built-in multiplier of 115-125% times the input amps to determine the overload trip point.

4.0 POWER SUPPLY (1-PHASE)

Form 2207 – Action Facts

SUBMERSIBLE MOTORS INSTALLATION RECORD

- 4.2 Verify the motor control box and the motor are made by the same manufacturer.
- 4.3 Verify the motor control box hp rating and its voltage match the motor rating exactly. If not, a premature failure of the control box or motor should be expected.

5.0 HIGH SURGE PROTECTION

- 5.1 Verify the submersible motor has a dedicated surge arrester.
All submersible motors require a dedicated surge arrester.
Motors 5 hp and smaller marked “Equipped with Lightning Arrestors”, have a built-in surge arrester.
- 5.2 Verify the surge arrester is mounted as close to the motor as practical.
The location is usually in the pump panel, but sometimes it is placed at the well head in a separate electrical box.
- 5.3 Verify the surge arrester is grounded below the lowest drawdown water level.
This is usually accomplished by attaching the drop cable ground wire to the motor lead or the motor ground lug.
- 5.4 Verify the ground conductor size meets the minimum requirements of the National Electrical Code and all other relevant national, state, regional, and local codes.
- 5.5 Verify the motor is connected to both the electrical system ground and the motor.

6.0 ELECTRICAL DROP CABLE

- 6.1 Verify the temperature rating of the drop cable – typically 60 °C, 75 °C, 90 °C or 125 °C.
- 6.2 Verify if the cable is single conductor or jacketed conductor. Web cable is considered jacketed cable by regulating agencies.
- 6.3 Verify the conductor size – typically AWG, MCM or mm².
- 6.4 Verify if the conductor material is copper; if not, determine the material and contact the factory for acceptability.
- 6.5 Verify the drop cable meets or exceeds the requirements of the Franklin Application (AIM) manual.

Notice:

- If the service entrance to pump panel or the pump panel to motor cable is not a copper material, contact the factory for the correct length derating factors.

7.0 MOTOR COOLING

- 7.1 Verify that the well water temperature does not exceed the maximum ambient temperature indicated on the nameplate of the motor.
- 7.2 Verify there is a minimum of 10 feet of clear water between the bottom of the motor and the bottom of the well.
- 7.3 Verify that all water entering the well is coming from below the lowest part of the motor.
- 7.4 Verify the system pumping rate will never deliver less flow than is required by the Franklin Application (AIM) manual to flow by-and-around the full length of the motor for cooling purposes.
- 7.5 Verify that 3-phase motors above 7.5 hp in a vertical potable water well should not exceed 100 starts in 24 hours and each start should include a minimum of 3 minutes ON and 10 minutes OFF.

Notice:

- If any water is entering the well above the lowest part of the motor, a flow sleeve is required.

8.0 MOTOR-PUMP INSTALLATION

- 8.1 Verify that the drop cable is supported to the drop pipe every 10 feet.
- 8.2 Verify at least one spring loaded (non-drilled) check valve is in the drop pipe.
Preferably, the first check valve should be located at the top of the first pipe joint above the pump discharge (~20 feet) if the pump does not have a check built in to its discharge.
- 8.3 Verify all pipe joints are as tight as practical.
The minimum torque should never be less than 10 foot-pounds times the motor nameplate hp rating.
- 8.4 Verify the rotation of the pump is correct.
It is preferable to do this by checking the flow and current in both directions on 3-phase motors.
This can be done by having the electrician swap any two leads.
This is considered “best practice” since pumps under some conditions can supply amp readings and a visual flow observation that can be extremely misleading.

Form 2207 - Page 1

SUBMERSIBLE MOTORS INSTALLATION RECORD

RMA Number

KEY DEALER #

DISTRIBUTOR

Name: _____
 City: _____
 State: _____ Zip: _____

INSTALLER

Name: _____
 City: _____
 State: _____ Zip: _____

END USER

Name: _____
 City: _____
 State: _____ Zip: _____

Well ID or GPS: _____ Water Temperature: _____ °F °C

Application/Water Use (e.g. potable water, irrigation, municipal, fountain, etc.): _____

Date Installed (mm/yy): _____ Date Failed (mm/yy): _____ Motor Position Shaft-Up: Yes No

Operating Cycle: ON Time Per Start _____ Hrs. Mins. Time OFF Between Stop & Restart _____ Hrs. Mins.

MOTOR

Model: _____ Serial Number: _____ Date Code (if updated): _____

MOTOR OVERLOAD

System Typical Operating Current: _____ Amps @ _____ Volts

Overload: FE SubMonitor Input Amps _____ D3 Attached Yes No Fault Settings Attached Yes No

Other Manufacturer Model: _____ Dial Set at: _____ or Heater # _____

NEMA Class: 10 20 30 Ambient Compensated: Yes No

Power to Motor by: Full Volt Starter VFD Soft Starter VFD or Soft Starter Mfr. & Model: _____

PUMP

Manufacturer: _____

Model: _____

Stages: _____

Design Rating: _____ gpm @ _____ ft TDH

Horsepower Required by Pump End: _____

Actual Pump Delivery: _____ gpm @ _____ psi

What Controls When System Runs & Stops:

 (e.g. pressure, level, flow, manual on/off, timer, time clock etc.)

YOUR NAME / DATE

_____ / _____

WELL DATA (All measurements from well head down.)

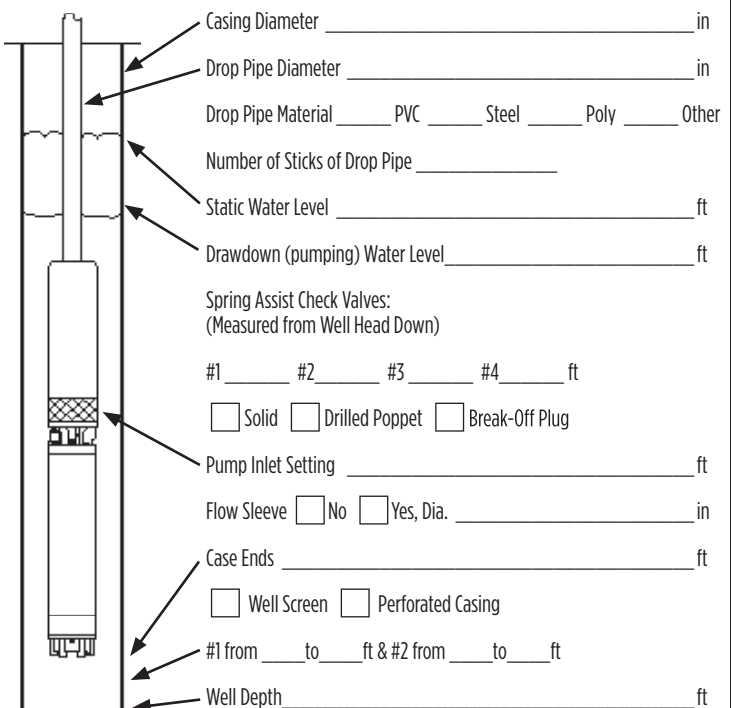

Form 2207 - Page 2

RMA Number

SUBMERSIBLE MOTORS INSTALLATION RECORD

TRANSFORMERS

Number of Transformers: Two Three Transformers Supply Motor Only: Yes No Unsure
Transformer #1: _____ kVA Transformer #2: _____ kVA Transformer #3: _____ kVA

POWER CABLES & GROUND WIRE

Service Entrance to Pump Control Panel:

1 Length: _____ ft. & Gauge: _____ AWG/MCM
Material: Copper Aluminum Construction: Jacketed Individual Conductors Web Twisted
Temperature Rating of Cable: 60 °C 75 °C 90 °C 125 °C or Insulation Type: _____ (e.g. THHN)

Pump Control Panel to Motor:

2 Length: _____ ft. & Gauge: _____ AWG/MCM
Material: Copper Aluminum Construction: Jacketed Individual Conductors Web Twisted
Temperature Rating of Cable: 60 °C 75 °C 90 °C 125 °C or Insulation Type: _____ (e.g. THHN)

Ground Wire Size: From Control Panel to Motor: _____ AWG/MCM

3 Control Grounded to (mark all that apply):
 Well Head Metal Casing Motor Driven Rod Power Supply

INCOMING VOLTAGE

No Load L1-L2 _____ L2-L3 _____ L1-L3 _____
Full Load L1-L2 _____ L2-L3 _____ L1-L3 _____

RUNNING AMPS & CURRENT BALANCE

Full Load L1 _____ L2 _____ L3 _____
% Unbalance: _____

CONTROL PANEL

1 Pump Panel Manufacturer/Fabricator: _____

Short Circuit Protection - Fuses or Circuit Breaker

Option #1 - Fuse

2 Manufacturer: _____ Model: _____ Rating: _____ Amps
Type: Time-Delay Standard

Option #2 - Circuit Breaker

Manufacturer: _____ Model: _____ Rating: _____ Amps Setting: _____

Starter - Full Voltage, Reduced Voltage, Soft-Starter or VFD (Variable Frequency Drive)

Option #1 - Full Voltage

Manufacturer: _____ Model: _____ Size: _____ Contacts: NEMA IEC

Option #2 - Reduced Voltage

Manufacturer: _____ Model: _____ Ramp Time to Full Voltage: _____ sec.

3 Option #3 - Soft-Starter or VFD

Manufacturer: _____ Model: _____ Max. Continuous Amp Output Rating: _____

Min. Setting: _____ Hz & GPM: _____ Max. Setting: _____ Hz & GPM: _____

Start Ramp Time to 30 Hz: _____ sec. Stop Mode: Power Off Coast 30-0 Hz Ramp _____ sec.

Special Output Filter Purchased: Yes No

Output Filter Manufacturer: _____ Model: _____ % Reactance: _____

4 Surge Arrestor: No Yes, Manufacturer: _____ Model: _____

Form 3655 Booster Installation Record

SUBMERSIBLE MOTOR

RMA Number

Date ____/____/____ Filled In By _____

INSTALLATION

Owner/User _____ Telephone (____) _____

Address _____ City _____ State _____ Zip _____

Installation Site, If Different _____

Contact _____ Telephone (____) _____

System Application _____

System Manufactured By _____ Model _____ Serial No. _____

System Supplied By _____ City _____ State _____ Zip _____

Is this a "HERO" system (10.0 - 10.5 PH)? Yes No

MOTOR

Model No. _____ Serial No. _____ Date Code _____

Horsepower _____ Voltage _____ Single-Phase Three-Phase Diameter _____ in.

Slinger Removed? Yes No Check Valve Plug Removed? Yes No

Motor Fill Solution Standard DI Water Model No. _____ Serial No. _____ Date Code _____

PUMP

Manufacturer _____ Model _____ Serial No. _____

Stages _____ Diameter _____ Flow Rate Of _____ gpm At _____ TDH

Booster Case Internal Diameter _____ Material _____

CONTROLS AND PROTECTIVE DEVICES

SubMonitor? Yes No If Yes, Warranty Registration No. _____

If Yes, Overload Set? Yes No Set At _____

Underload Sets? Yes No Set At _____

VFD or Reduced Voltage Starter? Yes No If Yes, Type _____

Mfr. _____ Setting _____ % Full Voltage In _____ sec

Pump Panel? Yes No If Yes, Mfr. _____ Size _____

Magnetic Starter/Contactor Mfr. _____ Model _____ Size _____

Heaters Mfr. _____ No. _____ If Adjustable Set At _____

Fuses Mfr. _____ Size _____ Type _____

Surge Arrestor Mfr. _____ Model _____

Controls Are Grounded to _____ with No. _____ Wire

Inlet Pressure Control Yes No If Yes, Mfr. _____ Model _____ Setting _____ psi Delay _____ sec

Inlet Flow Control Yes No If Yes, Mfr. _____ Model _____ Setting _____ gpm Delay _____ sec

Outlet Pressure Control Yes No If Yes, Mfr. _____ Model _____ Setting _____ psi Delay _____ sec

Outlet Flow Control Yes No If Yes, Mfr. _____ Model _____ Setting _____ gpm Delay _____ sec

Water Temperature Control Yes No If Yes, Mfr. _____ Model _____ Delay _____ sec

Set At _____ °F or _____ °C Located _____

Form 3655 Booster Installation Record

SUBMERSIBLE MOTOR

INSULATION CHECK

Initial Megs: Motor & Lead Only Black (T1/U1) _____ Yellow (T2/V1) _____ Red (T3/W1) _____

Installed Megs: Motor, Lead, & Cable Black (T1/U1) _____ Yellow (T2/V1) _____ Red (T3/W1) _____

VOLTAGE TO MOTOR

Non-Operating: B-Y (T1/U1 - T2/V1) _____ Y-R (T2/V1 - T3/W1) _____ R-B (T3/W1 - T1/U1) _____

At Rated Flow of _____ gpm B-Y (T1/U1 - T2/V1) _____ Y-R (T2/V1 - T3/W1) _____ R-B (T3/W1 - T1/U1) _____

At Open Flow _____ gpm B-Y (T1/U1 - T2/V1) _____ Y-R (T2/V1 - T3/W1) _____ R-B (T3/W1 - T1/U1) _____

AMPS TO MOTOR

At Rated Flow of _____ gpm Black (T1/U1) _____ Yellow (T2/V1) _____ Red (T3/W1) _____

At Open Flow _____ gpm Black (T1/U1) _____ Yellow (T2/V1) _____ Red (T3/W1) _____

At Shut-Off* Black (T1/U1) _____ Yellow (T2/V1) _____ Red (T3/W1) _____

*Do **NOT** run at Shut-Off more than two (2) minutes.

Inlet Pressure _____ psi Outlet Pressure _____ psi Water Temperature _____ °F or _____ °C

If you have any questions or problems, call the Franklin Electric Toll-Free Hotline: 1-800-348-2420

Comments: _____

PLEASE SKETCH THE SYSTEM

SUBDRIVE INSTALLATION RECORD

CONTACT INFORMATION

DISTRIBUTOR	INSTALLER	END-USER
NAME:	NAME:	NAME:
CITY:	CITY:	CITY:
STATE:	STATE:	STATE:
ZIP:	ZIP:	ZIP:

DRIVE INFORMATION

MODEL NO.:	SERIAL NO.:	INSTALL DATE:	FAILURE DATE:
------------	-------------	---------------	---------------

APPLICATION INFORMATION

MOTOR VOLTAGE:	115VAC	230VAC	460VAC	MOTOR TYPE:	TWO-WIRE	THREE-WIRE	THREE-PHASE	
MOTOR MODEL:				MOTOR RATING (HP):	NEW INSTALL		EXISTING	AGE (YR):
PUMP MODEL:				PUMP RATING (HP):	PUMP FLOW (GPM):			
APPLICATION TYPE (CHECK ALL THAT APPLY):	RESIDENTIAL	COMMERCIAL	IRRIGATION	AGRICULTURE	PRESSURE BOOSTING			
APPLICATION DESCRIPTION:								

INSTALLATION INFORMATION

MEASURED INPUT VOLTAGE (VAC):			INPUT PHASE:	SINGLE-PHASE	THREE-PHASE		
INPUT PROTECTION:	CIRCUIT BREAKER	FUSED DISCONNECT	BREAKER/FUSE RATING (AMPS):				
INPUT POWER SOURCE:	PAD TRANSFORMER	POLE TRANSFORMER	GENERATOR	GENERATOR RATING (KW):			
SUPPLY PANEL TYPE:	MAIN PANEL	SUB-PANEL	OTHER:				
DRIVE LOCATION:	INDOOR	OUTDOOR	DIRECT SUNLIGHT	AMBIENT TEMPERATURE:		°F	°C
DESCRIPTION OF DRIVE LOCATION (BASEMENT, PUMP HOUSE, ETC):							
DRIVE SYSTEM:	STANDALONE	DUPLEX ALTERNATOR (ACCESSORY)		DUPLEX ALTERNATOR/MULTIDRIVE BUILT-IN			
PRESSURE SENSOR TYPE:	4-20MA TRANSDUCER	PRESSURE SENSOR/SWITCH		PRESSURE SETPOINT (PSI):			
PRESSURE TANK TYPE:	BLADDER	GALVANIZED	NO TANK	OTHER:			
PRESSURE TANK SIZE (GAL):				PRESSURE TANK PRE-CHARGE (PSI):			

POWER CABLE & GROUND WIRE

DRIVE INPUT

LENGTH (FT):	GAUGE (AWG/MCM):							
MATERIAL:	COPPER	ALUMINUM	TYPE:	JACKETED	INDIVIDUAL CONDUCTORS	WEB	TWISTED	OTHER:
TEMPERATURE RATING:	60 °C	75 °C	90 °C	125 °C	INSULATION RATING (E.G. THHN):			

OFFSET WIRE

LENGTH (FT):	GAUGE (AWG/MCM):							
MATERIAL:	COPPER	ALUMINUM	TYPE:	JACKETED	INDIVIDUAL CONDUCTORS	WEB	TWISTED	OTHER:
TEMPERATURE RATING:	60 °C	75 °C	90 °C	125 °C	INSULATION RATING (E.G. THHN):			

DROP WIRE (SUBMERSIBLE PUMPS)

LENGTH (FT):	GAUGE (AWG/MCM):							
MATERIAL:	COPPER	ALUMINUM	TYPE:	JACKETED	INDIVIDUAL CONDUCTORS	WEB	TWISTED	OTHER:
TEMPERATURE RATING:	60 °C	75 °C	90 °C	125 °C	INSULATION RATING (E.G. THHN):			





TECHNICAL SUPPORT

1-800-348-2420

Option 1 - Franklin Water | Option 2 - Industrial & Pioneer Pump | Option 3 - Little Giant | Option 4 - Water Treatment

Call Franklin's toll free TECHNICAL SUPPORT for answers to your pump and motor installation questions. When you call, a Franklin expert will offer assistance in troubleshooting and provide immediate answers to your system application questions. Technical support is also available online.



HANDS-ON ADVICE THAT KEEPS YOU UP AND RUNNING

The AIM (Application, Installation, & Maintenance) App provides contractors with instantaneous information to make working in the field easier. Access the most commonly used Franklin Electric submersible motor sections of the legendary print version into an easy-to-access digital form.

Discover intuitive support for a variety of technical needs: find motor specifications by model number or rating – or use the cable selection calculator to easily size wire/cable.

