

## SERVICE MANUAL

# 4SCU16LE/14LB



This is a safety alert symbol and should never be ignored. When you see this symbol on labels or in manuals, be alert to the potential for personal injury or death.



### Table of Contents

Technical Specifications - 4SCU16LE .....	2
Technical Specifications - 4SCU14LB .....	5
Technical Specifications - 4SCU14LE-7 .....	8
Technical Specifications - 4SCU14LB-7 .....	10
Technical Specifications - 4SCU14LE-4 .....	12
Refrigerant Metering Device - Indoor Coil .....	16
Installation .....	16
Refrigeration Piping .....	19
Electrical Wiring .....	28
Sequence of Operation .....	32
Start-Up .....	32
Maintenance .....	33
Wiring Diagram .....	34
Servicing Units Void of Charge .....	38
System Refrigerant .....	38
Charge Labels .....	41
Start-Up and Performance Checklist .....	43

### WARNING

Improper installation, adjustment, alteration, service or maintenance can cause property damage, personal injury or loss of life. Installation and service must be performed by a licensed professional HVAC installer (or equivalent), service agency or the gas supplier.

### WARNING



Electric shock hazard.

Can cause injury or death. Before attempting to perform any service or maintenance, turn the electrical power to unit OFF at disconnect switch(es). Unit may have multiple power supplies.

### CAUTION

As with any mechanical equipment, contact with sharp sheet metal edges can result in personal injury. Take care while handling this equipment and wear gloves and protective clothing.



(P) 508219-01

# Technical Specifications - 4SCU16LE

## MODEL NUMBER GUIDE

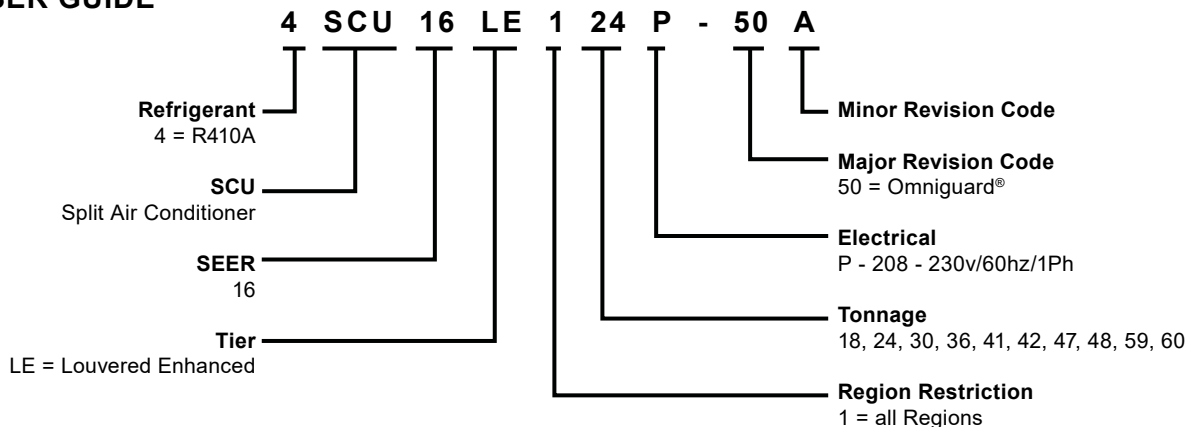

## PHYSICAL AND ELECTRICAL DATA

Model	Voltage/Hz/Phase	Voltage Range	Min. Circuit Amp.	Max. Over Current Device (amps)	Compressor		Fan Motor		
					Rated Load (amps)	Locked Rotor (amps)	Rated Load (amps)	Rated HP	Nom. RPM
4SCU16LE118P-50	208-230/60/1	197-253	11.9	20	9.0	48	0.7	1/10	1075
4SCU16LE124P-50	208-230/60/1	197-253	14.6	25	10.9	52	1.0	1/6	825
4SCU16LE130P-50	208-230/60/1	197-253	17.0	25	12.8	63	1.0	1/6	825
4SCU16LE136P-50	208-230/60/1	197-253	18.0	30	13.6	79	1.0	1/6	825
4SCU16LE141P-50	208-230/60/1	197-253	19.3	30	14.7	75	1.0	1/6	825
4SCU16LE142P-50	208-230/60/1	197-253	23.4	40	17.9	112	1.0	1/6	825
4SCU16LE147P-50	208-230/60/1	197-253	22.9	35	16.9	94	1.8	1/3	825
4SCU16LE148P-50	208-230/60/1	197-253	24.2	40	18.0	94	1.7	1/4	825
4SCU16LE159P-50	208-230/60/1	197-253	28.8	45	20.8	127	2.8	1/3	V Spd
4SCU16LE160P-50	208-230/60/1	197-253	29.6	50	22.2	128	1.8	1/3	825

## UNIT DIMENSIONS (IN.)

Model No.	Dimensions			Shipping Weight (lbs.)
	A - width	B - depth	C - Height	
4SCU16LE118P-50	24.75	26.75	29.75	155
4SCU16LE124P-50	29.38	31.25	29.75	171
4SCU16LE130P-50	29.38	31.25	37.75	187
4SCU16LE136P-50	29.38	31.25	29.75	205
4SCU16LE141P-50	29.38	31.25	37.75	227
4SCU16LE142P-50	29.38	31.25	37.75	234
4SCU16LE147P-50	35.75	37.75	33.75	272
4SCU16LE148P-50	29.38	31.25	37.75	255
4SCU16LE159P-50	35.75	37.75	43.75	284
4SCU16LE160P-50	35.75	37.75	43.75	284

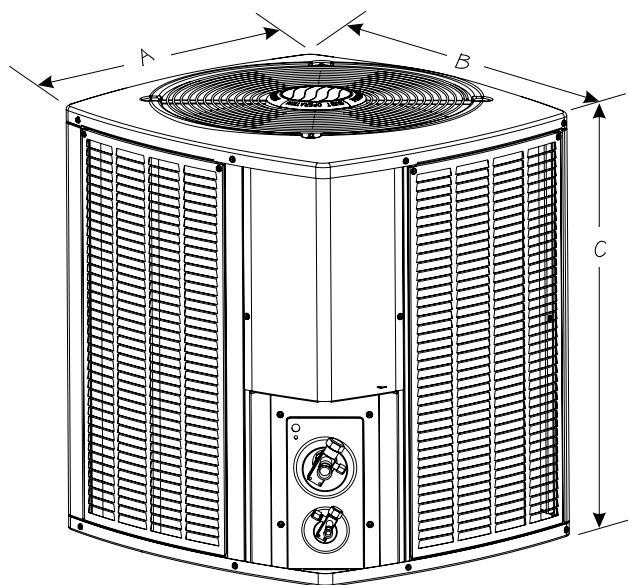

Note:

Weights listed are unit weights with packaging  
Dimensions listed are unit sizes w/o packaging

## SOUND RATINGS

Model	Sound Power <sup>1</sup>	Estimated Sound Pressure (dBA) <sup>2</sup>		
		Approximate Distance <sup>3</sup>		
		3.3 Feet (1 Meter)	6.6 Feet (2 Meters)	9.8 Feet (3 Meters)
4SCU16LE118P-50	70	62	56	52
4SCU16LE124P-50	77	69	63	59
4SCU16LE130P-50	75	67	61	57
4SCU16LE136P-50	78	70	64	60
4SCU16LE141P-50	74	66	60	56
4SCU16LE142P-50	77	69	63	59
4SCU16LE147P-50	79	71	65	61
4SCU16LE148P-50	76	68	62	58
4SCU16LE159P-50	77	69	63	59
4SCU16LE160P-50	78	70	64	60

1 Rated in accordance with AHRI standard 270 (2015). AHRI Standard 270 establishes a method of rating outdoor unitary equipment in terms of Sound Power.

2 Rated in accordance with AHRI standard 275 (2010). AHRI Standard 275 provides the calculations for estimating the A-Weighted Sound Pressure at a given distance from the equipment. That is a more useful number because that is what humans will hear.

3 Based only on distance factor; other factors may change this value such as:

- Unit location (reflective surfaces adjacent to the unit)
- Barrier shielding sources
- Sound path/elevation
- Outside noise sources

## ACCESSORIES

System Accessory	Where Used	Kit Number	Purpose
Liquid Line solenoid	All models	60M52	Prevents liquid migration to the compressor especially for high liquid riser applications
Low ambient (cooling operation)	All models	34M72	Enables cooling demand down to 30 °F. Will require freeze stat, CC heater and TXV
Compressor Short Cycle Protector	All models	47J27	Delays compressor start 5-7 minutes to prevent short cycling
Hard Start	18	10J42	Scroll compressors usually do not require hard start; maybe needed for utility brown-out or low voltage areas
Hard Start	24 thru 60	88M91	
Crankcase Heater	18, 24, 30, 36	93M04	Prevents liquid migration to compressor in cold weather
Crankcase Heater	41, 42	93M05	
Crankcase Heater	47, 48, 59, 60	Factory Installed	
Sound Cover	Factory Installed		Lowers compressor sound level
Loss of Charge Kit	Factory Installed		Protects the compressor if refrigerant charge is too low
<b>Additional System Accessories (indoor section)</b>			
TXV Kit	18, 24, 30	H4TXV01	TXVs provide superior refrigerant flow control, comfort and efficiency compared to pistons
	36, 41, 42, 47, 48	H4TXV02	
	59, 60	H4TXV03	
Outdoor Thermostat - electric heat	All models	10Z23	Prevents electric heat operation above specific ambient conditions
Outdoor Thermostat - Mounting box	All models	31461	Mounting box for outdoor thermostat
Freezestat	All models	93G35	Protects the compressor at low suction pressure conditions
Overflow switch	All models	11U75	Turn the system off, if condensate water overflows due to clogged drain pipes
Blower time delay	All models	58M81	Improves system efficiency and comfort
Single point power supply	All models	21H39	Provide single power source in one junction box
Auxiliary blower relay	All models	85W66	Maybe required to select multiple indoor blower speeds

## REFRIGERATION DATA

Outdoor Model	Charge (oz) <sup>6</sup>	Refrigerant Connection				Refrigerant Line Size		Indoor Expansion Device	
		Outdoor		Indoor (DTC) <sup>7</sup>		Suction	Liquid	Piston	TXV <sup>1</sup>
		Suction	Liquid	Suction	Liquid				
4SCU16LE118P-50	73	3/4	3/8	3/4	3/8	3/4	3/8	0.052	H4TXV01
4SCU16LE124P-50	73	3/4	3/8	3/4	3/8	3/4	3/8	0.06	H4TXV01
4SCU16LE130P-50	100	3/4	3/8	3/4	3/8	3/4	3/8	0.067	H4TXV01
4SCU16LE136P-50	113	7/8	3/8	7/8	3/8	7/8	3/8	0.072	H4TXV02
4SCU16LE141P-50	144	7/8	3/8	7/8	3/8	7/8	3/8	†	H4TXV02
4SCU16LE142P-50	140	7/8	3/8	7/8	3/8	7/8	3/8	0.081	H4TXV02
4SCU16LE147P-50	176	7/8	3/8	7/8	3/8	7/8	3/8	†	H4TXV02
4SCU16LE148P-50	156	7/8	3/8	7/8	3/8	7/8	3/8	0.083	H4TXV02
4SCU16LE159P-50	192	7/8**	3/8	7/8	3/8	1-1/8	3/8	†	H4TXV03
4SCU16LE160P-50	192	7/8**	3/8	7/8	3/8	1-1/8	3/8	0.097	H4TXV03

\*Factory charged for 15 feet of line set

\*\* Adapter shipped with unit

† TXV only

## COOLING PERFORMANCE WITH DTC<sup>1</sup>

Outdoor Model	Indoor Model	Capacity (BTUH)	EER	SEER
4SCU16LE118P-50	EAC4X24B	18,000	12.20	14.00
4SCU16LE124P-50	EAC4X24B	24,000	12.20	14.25
4SCU16LE130P-50	EAC4X30B	28,400	12.20	14.25
4SCU16LE136P-50	EAC4X36B	34,200	12.20	14.50
4SCU16LE141P-50	EAC4X49C	38,000	12.20	15.10
4SCU16LE142P-50	EAC4X49C	40,000	12.20	14.25
4SCU16LE147P-50	EAC4X60C	46,000	12.20	14.50
4SCU16LE148P-50	EAC4X60C	46,000	12.20	14.25
4SCU16LE159P-50	EAC4X60C	57,500	12.00	14.25
4SCU16LE160P-50	EAC4X60C	57,000	11.70	14.00

<sup>1</sup> DTC = Designated Tested Combination

### NOTE:

For the latest ratings, please see  
[www.alliedratings.com](http://www.alliedratings.com) or [www.AHRIdirectory.org](http://www.AHRIdirectory.org)

# Technical Specifications - 4SCU14LB

## MODEL NUMBER GUIDE

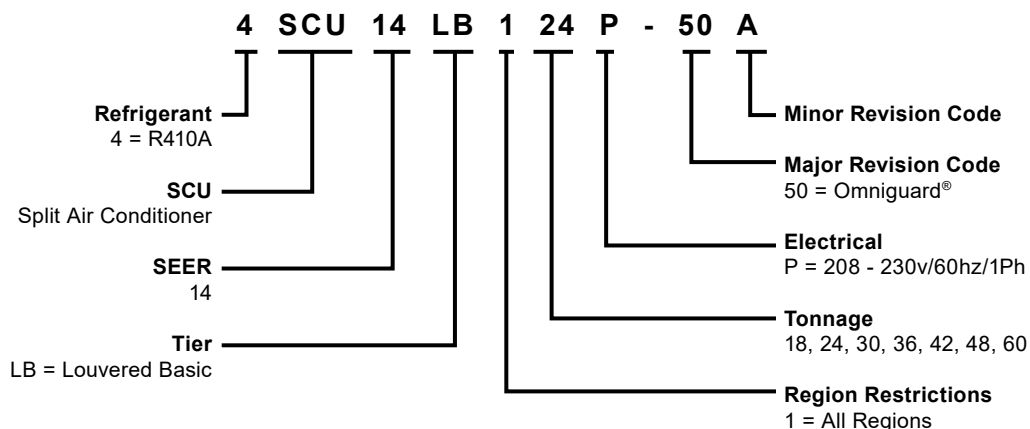

## PHYSICAL AND ELECTRICAL DATA

Model	Voltage/Hz/Phase	Voltage Range	Min. Circuit Amp.	Max. Over Current Device (amps)	Compressor		Outdoor Fan Motor		
					Rated Load (amps)	Locked Rotor (amps)	Rated Load (amps)	Rated HP	Nom. RPM
4SCU14LB118P-50	208-230/60/1	197-253	11.9	20	9.0	48	0.7	1/10	1075
4SCU14LB124P-50	208-230/60/1	197-253	14.6	25	10.9	52	1.0	1/6	825
4SCU14LB130P-50	208-230/60/1	197-253	17.0	25	12.8	63	1.0	1/6	825
4SCU14LB136P-50	208-230/60/1	197-253	18.0	30	13.6	79	1.0	1/6	825
4SCU14LB142P-50	208-230/60/1	197-253	23.4	40	17.9	112	1.0	1/6	825
4SCU14LB148P-50	208-230/60/1	197-253	24.2	40	18.0	94	1.7	1/4	825
4SCU14LB160P-50	208-230/60/1	197-253	29.6	50	22.2	128	1.8	1/3	825

## UNIT DIMENSIONS (IN.)

Model	Dimensions (inch)			Shipping Weight (lbs.)
	A - Width	B - Depth	C - Height	
4SCU14LB118P-50	24.75	26.75	29.75	155
4SCU14LB124P-50	29.38	31.25	29.75	171
4SCU14LB130P-50	29.38	31.25	37.75	187
4SCU14LB136P-50	29.38	31.25	29.75	205
4SCU14LB142P-50	29.38	31.25	37.75	234
4SCU14LB148P-50	29.38	31.25	37.75	255
4SCU14LB160P-50	35.75	37.75	43.75	284

Note:

Dimensions listed are unit sizes w/o packaging  
Weights listed are units weights with packaging.

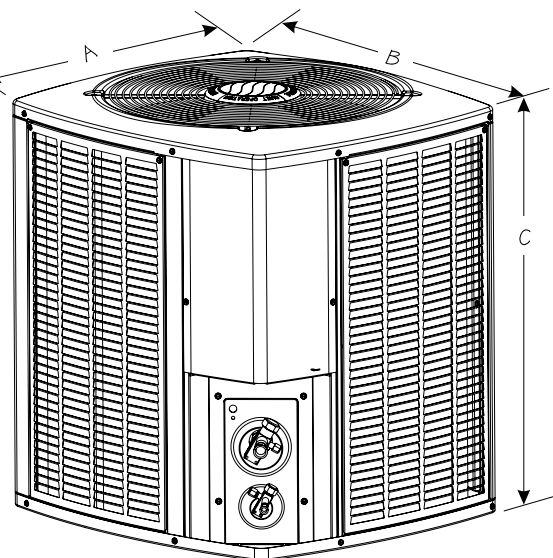

## SOUND RATINGS

Model	Sound Power <sup>1</sup>	Estimated Sound Pressure (dBA) <sup>2</sup>		
		Approximate Distance <sup>3</sup>		
		3.3 Feet (1 Meter)	6.6 Feet (2 Meters)	9.8 Feet (3 Meters)
4SCU14LB118P-50	72	64	58	54
4SCU14LB124P-50	78	70	64	60
4SCU14LB130P-50	76	68	62	58
4SCU14LB136P-50	78	70	64	60
4SCU14LB142P-50	78	70	64	60
4SCU14LB148P-50	77	69	63	59
4SCU14LB160P-50	78	70	64	60

1 Rated in accordance with AHRI standard 270 (2015). AHRI Standard 270 establishes a method of rating outdoor unitary equipment in terms of Sound Power.

2 Rated in accordance with AHRI standard 275 (2010). AHRI Standard 275 provides the calculations for estimating the A-Weighted Sound Pressure at a given distance from the equipment. That is a more useful number because that is what humans will hear.

3 Based only on distance factor; other factors may change this value such as:

- Unit location (reflective surfaces adjacent to the unit)
- Barrier shielding sources
- Sound path/elevation
- Outside noise sources

## ACCESSORIES

System Accessory	Where Used	Kit Number	Purpose
Liquid Line solenoid	All models	60M52	Prevents liquid migration to the compressor especially for high liquid riser applications
Low ambient (cooling operation)	All models	34M72	Enables cooling demand down to 30 °F. Will require freeze stat, CC heater and TXV
Compressor Short Cycle protector	All models	47J27	Delays compressor start 5-7 minutes to prevent short cycling
Hard Start	18	10J42	Scroll compressors usually do not require hard start; maybe needed for utility brown-out or low voltage areas
	24 thru 60	88M91	
Crankcase Heater	18, 24, 30, 36	93M04	Prevents liquid migration to compressor in cold weather
	42	93M05	
	48, 60	Factory Installed	
Sound Cover	18, 24, 30, 36	14W00	Lowers compressor sound level
	42, 48, 60	14W01	
Loss of Charge Kit	All models	84M23	Protects the compressor if refrigerant charge is too low
<b>Additional System Accessories (indoor section)</b>			
TXV Kit	18, 24, 30	H4TXV01	TXVs provide superior refrigerant flow control, comfort and efficiency compared to pistons
	36, 42, 48	H4TXV02	
	60	H4TXV03	
Outdoor Thermostat - electric heat	All models	10Z23	Prevents electric heat operation above specific ambient conditions
Outdoor Thermostat - mounting box	All models	31461	Mounting box for outdoor thermostat
Freezestat	All models	93G35	Protects the compressor at low suction pressure conditions
Overflow switch	All models	11U75	Turn the system off, if condensate water overflows due to clogged drain pipes
Blower time delay	All models	58M81	Improves system efficiency and comfort
Single point power supply	All models	21H39	Provide single power source in one junction box
Auxiliary blower relay	All models	85W66	Maybe required to select multiple indoor blower speeds

## REFRIGERATION DATA

Outdoor Model	Charge (oz) <sup>6</sup>	Refrigerant Connection				Refrigerant Line Size		Indoor Expansion Device	
		Outdoor		Indoor (DTC) <sup>7</sup>		Suction	Liquid	Piston	TXV <sup>1</sup>
		Suction	Liquid	Suction	Liquid				
4SCU14LB118P-50	73	3/4	3/8	3/4	3/8	3/4	3/8	0.052	H4TXV01
4SCU14LB124P-50	73	3/4	3/8	3/4	3/8	3/4	3/8	0.060	H4TXV01
4SCU14LB130P-50	100	3/4	3/8	3/4	3/8	3/4	3/8	0.067	H4TXV01
4SCU14LB136P-50	113	7/8	3/8	7/8	3/8	7/8	3/8	0.072	H4TXV02
4SCU14LB142P-50	140	7/8	3/8	7/8	3/8	7/8	3/8	0.081	H4TXV02
4SCU14LB148P-50	156	7/8	3/8	7/8	3/8	7/8	3/8	0.083	H4TXV02
4SCU14LB160P-50	192	7/8**	3/8	7/8	3/8	1-1/8	3/8	0.097	H4TXV03

\* Factory charged for 15 feet of line set

\*\* Adapter shipped with unit

## COOLING PERFORMANCE WITH DTC<sup>1</sup>

Outdoor Model	Indoor Model	Capacity (BTUH)	EER	SEER
4SCU14LB118P-50	EAC4X24B	18,000	12.20	14.00
4SCU14LB124P-50	EAC4X24B	24,000	12.20	14.25
4SCU14LB130P-50	EAC4X30B	28,400	12.20	14.25
4SCU14LB136P-50	EAC4X36B	34,200	12.20	14.50
4SCU14LB142P-50	EAC4X49C	40,000	12.20	14.25
4SCU14LB148P-50	EAC4X60C	46,000	12.20	14.25
4SCU14LB160P-50	EAC4X60C	57,000	11.70	14.00

1 DTC = Designated Tested Combination

### NOTE:

For the latest ratings, please see  
[www.alliedratings.com](http://www.alliedratings.com) or [www.AHRIdirectory.org](http://www.AHRIdirectory.org)

# Technical Specifications - 4SCU14LE-7

## MODEL NUMBER GUIDE

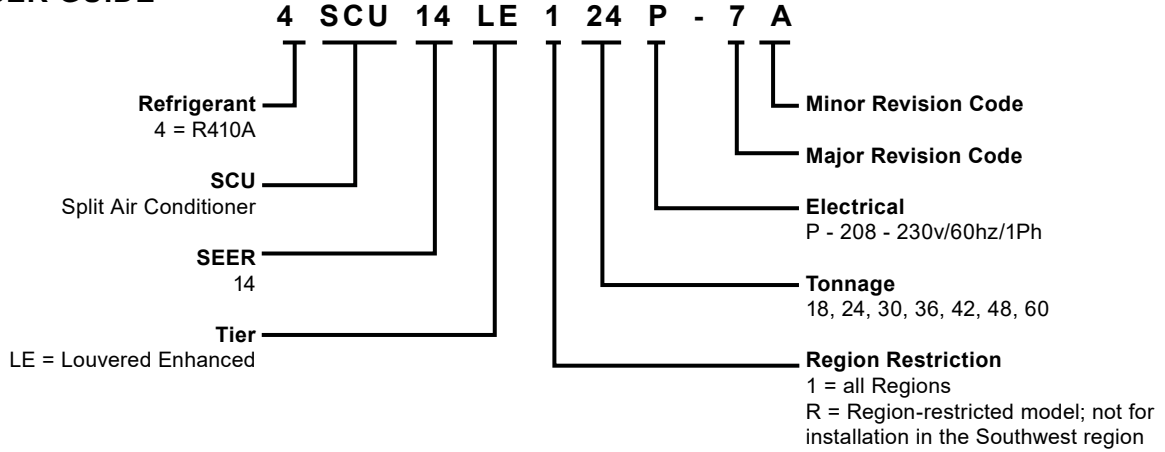

## PHYSICAL AND ELECTRICAL DATA

Model	Voltage/Hz/Phase	Voltage Range	Min. Circuit Amp.	Max. Over Current Device (amps)	Compressor		Fan Motor			Refrig. Charge+ (oz.)	Shipping Weight (lbs.)
					Rated Load (amps)	Locked Rotor (amps)	Rated Load (amps)	Rated HP	Nom. RPM		
4SCU14LE*18P-7	208-230/60/1	197-253	12.4	20	9.4	56.6	0.7	1/10	1075	77	150
4SCU14LE*24P-7	208-230/60/1	197-253	15.0	25	11.2	60.8	1.0	1/6	825	86	160
4SCU14LE*30P-7	208-230/60/1	197-253	17.0	25	12.8	67.8	1.0	1/6	825	100	180
4SCU14LE*36P-7	208-230/60/1	197-253	18.6	30	14.1	83.0	1.0	1/6	825	102	185
4SCU14LE*42P-7	208-230/60/1	197-253	24.1	40	17.9	113.0	1.7	1/4	825	160	208
4SCU14LE141P-7	208-230/60/1	197-253	22.6	35	16.7	79.0	1.7	1/4	825	161	210
4SCU14LE147P-7	208-230/60/1	197-253	26.7	45	19.9	109.0	1.8	1/3	825	179	251
4SCU14LE148P-7	208-230/60/1	197-253	26.6	45	19.8	109.0	1.7	1/4	825	174	220
4SCU14LE159P-7	208-230/60/1	197-253	34.1	50	25.0	134	2.8	1/3	825	178	235
4SCU14LE160P-7	208-230/60/1	197-253	34.8	60	26.4	134	1.8	1/3	825	192	253

**Note:**

Weights listed are unit weights with packaging

+ Factory charged for 15 feet offline set. Adjust per installation instructions.



## UNIT DIMENSIONS (IN.)

Model No.	Dimensions			Sound Rating (dBA)
	A - Width	B - Depth	C - Height	
4SCU14LE*18P-7	24.75	26.75	29.75	71
4SCU14LE*24P-7	29.38	31.25	29.75	76
4SCU14LE*30P-7	29.38	31.25	37.75	74
4SCU14LE*36P-7	29.38	31.25	37.75	74
4SCU14LE*42P-7	29.38	31.25	33.75	76
4SCU14LE141P-7	29.38	31.25	37.75	76
4SCU14LE147P-7	29.38	31.25	37.75	80
4SCU14LE148P-7	29.38	31.25	33.75	80
4SCU14LE159P-7	35.75	37.75	37.75	78
4SCU14LE160P-7	35.75	37.75	37.75	80

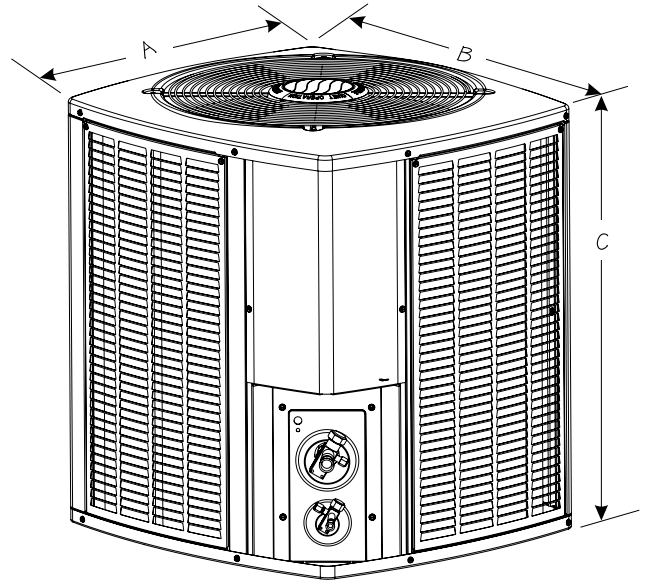

**Note:**

Dimensions listed are unit sizes w/o packaging

## ACCESSORIES

Description	Where Used	Kit Number
Crankcase Heater	18, 24, 30, 36	93M04
Hard Start	18	10J42
	24, 30, 36, 42, 48, 60	88M91
Compressor Low Ambient	All	34M72
Short Cycle Protector	All	47J27
Freezestat	3/8 tubing	93G35
	5/8 tubing	50A93
Time Delay Relay	All	58M81
Loss of Charge Kit	All	84M23 (factory installed)
Sound Blanket	18, 24, 30, 36, 41	14W00 (factory installed)
	42, 47, 48, 59, 60	14W01 (factory installed)
TXV Kit	18, 24, 30	A4TXV01
	36, 42, 48, 60	A4TXV02

# Technical Specifications - 4SCU14LB-7

## MODEL NUMBER GUIDE

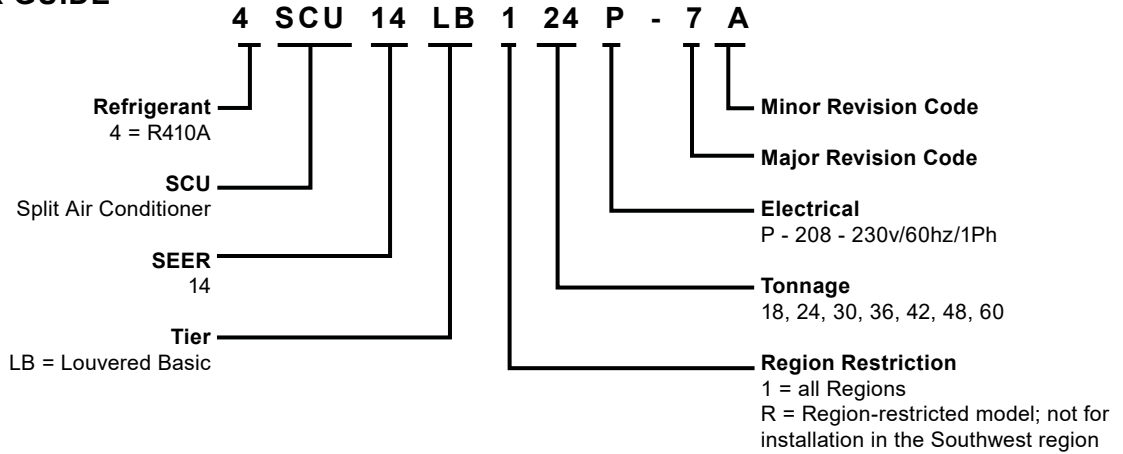

## PHYSICAL AND ELECTRICAL DATA

Model	Voltage/Hz/ Phase	Voltage Range	Min. Circuit Amp.	Max. Over Current Device (amps)	Compressor		Fan Motor			Refrig. Charge+ (oz.)	Shipping Weight (lbs.)
					Rated Load (amps)	Locked Rotor (amps)	Rated Load (amps)	Rated HP	Nom. RPM		
4SCU14LB*18P-7	208-230/60/1	197-253	12.4	20	9.4	56.6	0.7	1/10	1075	77	150
4SCU14LB*24P-7	208-230/60/1	197-253	15.0	25	11.2	60.8	1.0	1/6	825	86	160
4SCU14LB*30P-7	208-230/60/1	197-253	17.0	25	12.8	67.8	1.0	1/6	825	100	180
4SCU14LB*36P-7	208-230/60/1	197-253	18.6	30	14.1	83.0	1.0	1/6	825	102	185
4SCU14LB*42P-7	208-230/60/1	197-253	24.1	40	17.9	113.0	1.7	1/4	825	160	208
4SCU14LB148P-4	208-230/60/1	197-253	22.6	45	19.8	109.0	1.7	1/4	825	174	220
4SCU14LB160P-4	208-230/60/1	197-253	34.8	60	26.4	134.0	1.8	1/3	825	192	253

Note:  
Weights listed are unit weights with packaging  
+ Factory charged for 15 feet offline set. Adjust per installation instructions.

## UNIT DIMENSIONS (IN.)

Model No.	Dimensions			Sound Rating (dBA)
	A - Width	B - Depth	C - Height	
4SCU14LB*18P-7	24.75	26.75	29.75	76
4SCU14LB*24P-7	29.38	31.25	29.75	76
4SCU14LB*30P-7	29.38	31.25	37.75	76
4SCU14LB*36P-7	29.38	31.25	37.75	76
4SCU14LB*42P-7	29.38	31.25	33.75	76
4SCU14LB148P-4	29.38	31.25	33.75	80
4SCU14LB160P-4	35.75	37.75	37.75	80

Note:  
Dimensions listed are unit sizes w/o packaging

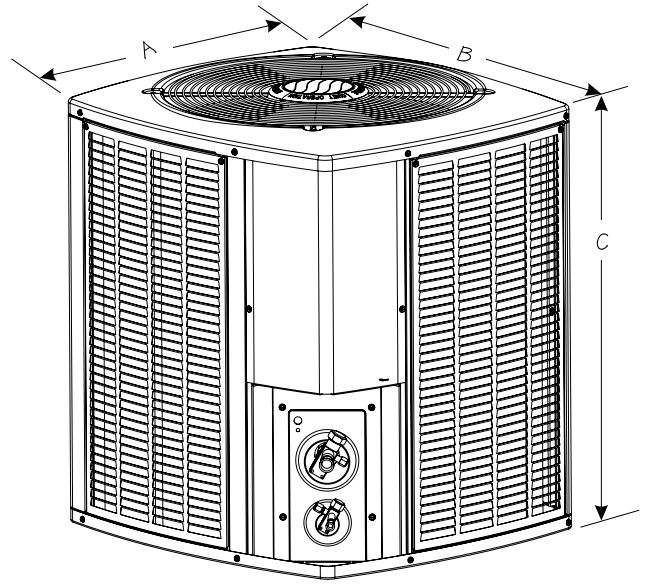

## ACCESSORIES

Description	Where Used	Kit Number
Crankcase Heater	All	93M04
Hard Start	18	10J42
	24, 30, 36, 42, 48, 60	88M91
Compressor Low Ambient	All	34M72
Short Cycle Protector	All	47J27
Freezestat	3/8 tubing	93G35
	5/8 tubing	50A93
Time Delay Relay	All	58M81
Loss of Charge Kit	All	84M23 (factory installed)
Sound Blanket	18, 24, 30, 36	14W00 (factory installed)
	42, 48, 60	14W01 (factory installed)
TXV Kit (H4TXV01)	18, 24, 30	1.851363
TXV Kit (H4TXV02)	36, 42, 48, 60	1.851364

# Technical Specifications - 4SCU14LE-4

## MODEL NUMBER GUIDE

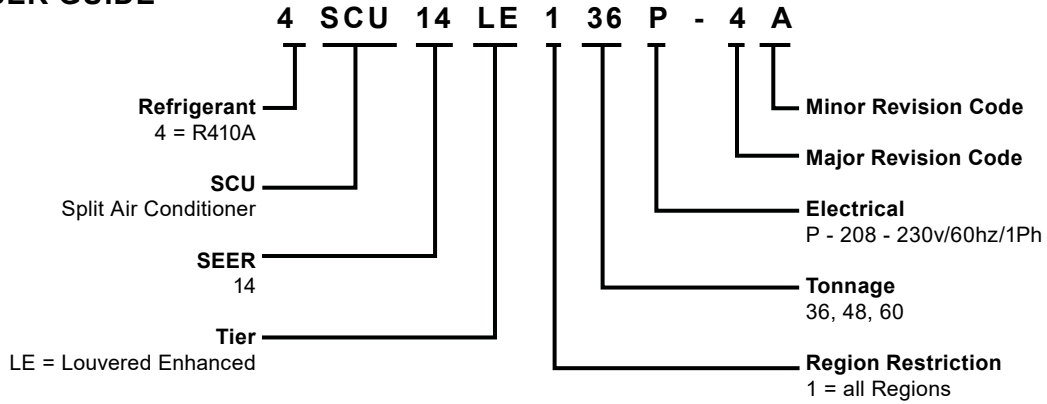

## PHYSICAL AND ELECTRICAL DATA

Model	Voltage/Hz/ Phase	Voltage Range	Min. Circuit Amp.	Max. Over Current Device (amps)	Compressor		Fan Motor			Refrig. Charge+ (oz.)	Shipping Weight (lbs.)
					Rated Load (amps)	Locked Rotor (amps)	Rated Load (amps)	Rated HP	Nom. RPM		
4SCU14LE118P-4	208-230/60/1	197-253	12.0	20	9.0	48	0.7	1/10	1075	91	138
4SCU14LE124P-4	208-230/60/1	197-253	18.7	30	13.4	58	1.1	1/6	825	92	146
4SCU14LE130P-4	208-230/60/1	197-253	17.2	30	12.9	64	1.1	1/6	825	107	172
4SCU14LE136P-4	208-230/60/1	197-253	18.7	30	14.1	77	1.1	1/6	825	107	177
4SCU14LE141P-4	208-230/60/1	197-253	22.8	35	16.7	79	1.7	1/4	825	161	210
4SCU14LE142P-4	208-230/60/1	197-253	24.1	40	17.9	112	1.7	1/4	825	138	208
4SCU14LE147P-4	208-230/60/1	197-253	26.7	45	19.9	109	1.8	1/3	825	179	251
4SCU14LE148P-4	208-230/60/1	197-253	27.9	45	19.8	109	1.7	1/4	825	174	220
4SCU14LE159P-4	208-230/60/1	197-253	34.1	50	25.0	134	2.8	1/3	825	178	235
4SCU14LE160P-4	208-230/60/1	197-253	34.8	60	26.4	134	1.8	1/3	825	192	253

Note:

Weights listed are unit weights with packaging

+ Factory charged for 15 feet offline set. Adjust per installation instructions.

## UNIT DIMENSIONS (IN.)

Model No.	Dimensions			Sound Rating (dBA)
	A - width	B - depth	C - Height	
4SCU14LE118P-4	24.75	26.75	29.75	76
4SCU14LE124P-4	29.38	31.25	29.75	76
4SCU14LE130P-4	29.38	31.25	37.75	76
4SCU14LE136P-4	29.38	31.25	29.75	76
4SCU14LE141P-4	29.38	31.25	37.75	76
4SCU14LE142P-4	29.38	31.25	37.75	80
4SCU14LE147P-4	35.75	37.75	33.75	80
4SCU14LE148P-4	29.38	31.25	37.75	80
4SCU14LE159P-4	35.75	37.75	43.75	78
4SCU14LE160P-4	35.75	37.75	43.75	80

Note:

Dimensions listed are unit sizes w/o packaging

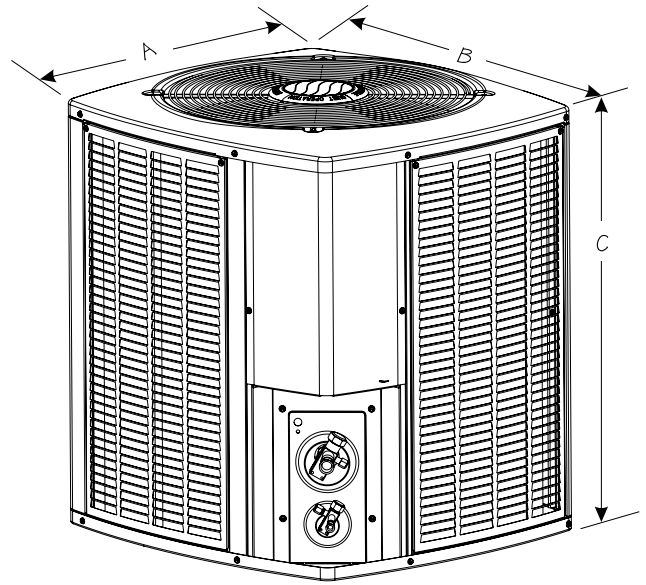

## ACCESSORIES

Description	Where Used	Kit Number
Crankcase Heater	All	93M04
Hard Start	18	10J42
	24, 30, 36, 41, 42, 47, 48, 59, 60	88M91
Compressor Low Ambient	All	34M72
Short Cycle Protector	All	47J27
Freezestat	3/8 tubing	93G35
	5/8 tubing	50A93
Time Delay Relay	All	58M81
Loss of Charge Kit	All	84M23 (factory installed)
Sound Blanket	18, 24, 30, 36, 41	14W00
	42, 47, 48, 59, 60	14W01

## FAN BLADE SPECS

4SCU16LE*-50	Fan Blade			
	Dia.	#of Blades	Pitch	Part #
-18	18	3	27	98M18
-24	22	3	26	43W37
-30	22	3	26	43W37
-36	22	3	26	15X85
-41	22	3	26	43W37
-42	22	3	26	43W37
-47	26	4	22	21W10
-48	22	4	32	30W24
-59	26	4	22	21W10
-60	26	4	22	21W10

4SCU14LB*-50	Fan Blade			
	Dia.	#of Blades	Pitch	Part #
-18	18	3	27	98M18
-24	22	3	26	43W37
-30	22	3	26	43W37
-36	22	3	26	15X85
-41	22	3	26	43W37
-42	22	3	26	43W37
-47	26	4	22	21W10
-48	22	4	32	30W24
-59	26	4	22	21W10
-60	26	4	22	21W10

4SCU14L**-4,5,6,7	Fan Blade			
	Dia.	#of Blades	Pitch	Part #
-18	18	3	27	98M18
-24	22	3	26	43W37
-30	22	3	26	43W37
-36	22	3	26	43W37
-41	22	3	30	30W23
-42	22	4	32	30W24
-47	26	4	22	21W10
-48	22	4	32	30W24
-59	26	4	22	21W10
-60	26	4	22	21W10

NOTE — Plumbing layout and compressor type may vary between model sizes.

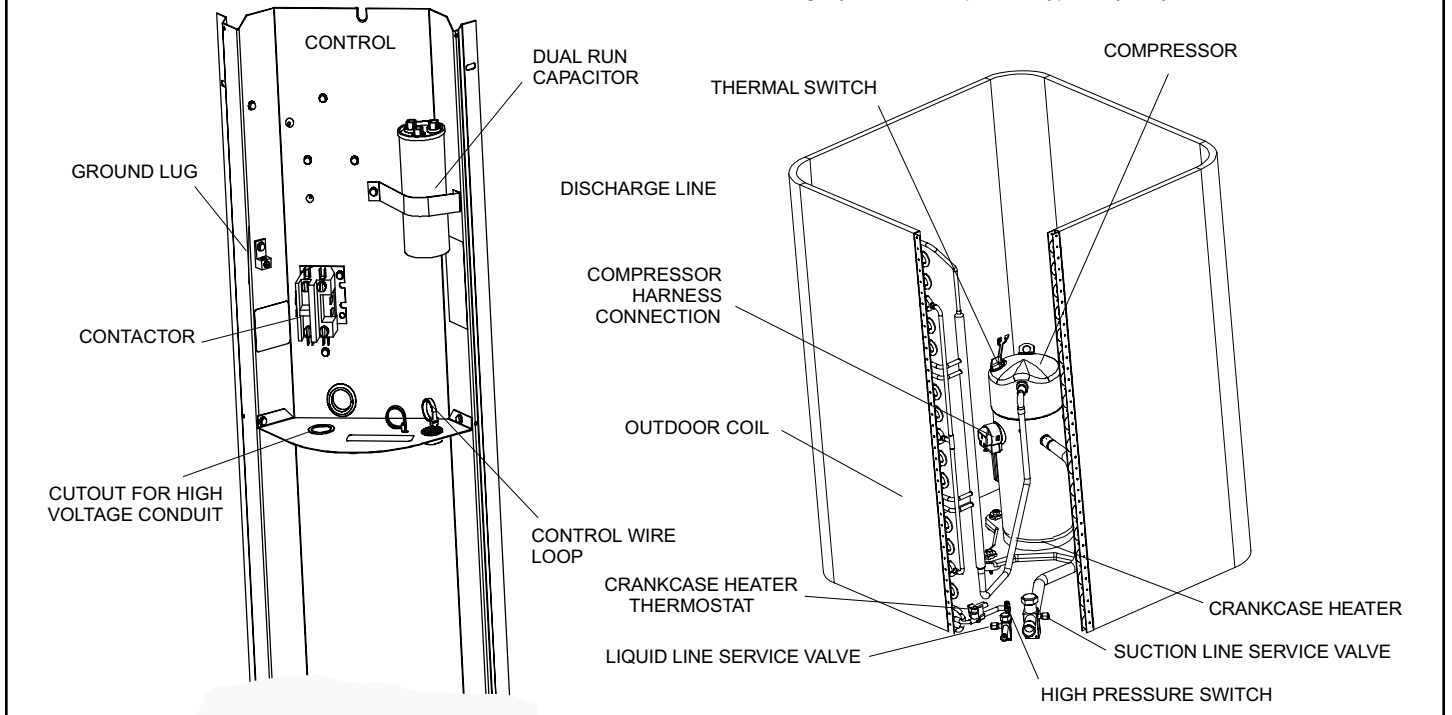

**Figure 1. Typical Parts Arranegment**

## Refrigerant Metering Device - Indoor Coil

For correct metering device, refer to chart below.

Outdoor Model	Orifice Size	Indoor Expansion Device	Outdoor Model	Orifice Size	Indoor Expansion Device
4SCU14L*118P-7	0.053	A4TXV01	4SCU14LE118P-4	0.053	A4TXV01
4SCU14LBR18P-7	0.053	A4TXV01	4SCU14LE124P-4	0.057	A4TXV01
4SCU14L*124P-7	0.057	A4TXV01	4SCU14LE130P-4	0.065	A4TXV01
4SCU14LBR24P-7	0.057	A4TXV01	4SCU14LE136P-4	0.071	A4TXV01
4SCU14L*130P-7	0.065	A4TXV01	4SCU14LE141P-4	N/A	A4TXV02
4SCU14LBR30P-7	0.065	A4TXV01	4SCU14LE142P-4	N/A	A4TXV02
4SCU14L*136P-7	0.071	A4TXV01	4SCU14LE147P-4	N/A	A4TXV02
4SCU14LBR36P-7	0.071	A4TXV01	4SCU14LE148P-4	N/A	A4TXV02
4SCU14L*142P-7	N/A	A4TXV02	4SCU14LE159P-4	N/A	A4TXV02
4SCU14LBR42P-7	N/A	A4TXV02	4SCU14LE160P-4	N/A	A4TXV02

Table 1.

These instructions are intended as a general guide and do not supersede local codes in any way. Consult authorities who have jurisdiction before installation.

### Installation

**NOTE:** *In some cases, noise in the living area has been traced to gas pulsations from improper installation of equipment.*

- Locate unit away from windows, patios, decks, etc. where unit operation sounds may disturb customer.
- Leave some slack between structure and unit to absorb vibration.
- Place a sound-absorbing material, such as Isomode, under the unit if it will be installed in a location or position that will transmit sound or vibration to the living area or adjacent buildings.
- In heavy snow areas, do not locate the unit where drifting snow will occur. The unit base should be elevated above the depth of average snows.

**NOTE:** *Elevation of the unit may be accomplished by constructing a frame using suitable materials. If a support frame is constructed, it must not block drain holes in unit base.*

- When installed in areas where low ambient temperatures exist, locate unit so winter prevailing winds do not blow directly into outdoor coil.

- Locate unit away from overhanging roof lines which would allow water or ice to drop on, or in front of, coil or into unit.

When outdoor unit is connected to factory-approved indoor unit, outdoor unit contains system refrigerant charge for operation with matching indoor unit when connected by 15 ft. of field-supplied tubing. For proper unit operation, check refrigerant charge using charging information located on control box cover.

### Outdoor Section

Zoning ordinances may govern the minimum distance the condensing unit can be installed from the property line.

### Install on a Solid, Level Mounting Pad

The outdoor section is to be installed on a solid foundation. This foundation should extend a minimum of 2" (inches) beyond the sides of the outdoor section. To reduce the possibility of noise transmission, the foundation slab should NOT be in contact with or be an integral part of the building foundation. See Figure 2.

If conditions or local codes require the unit be attached to pad or mounting frame, tie down bolts should be used and secured to unit base pan.



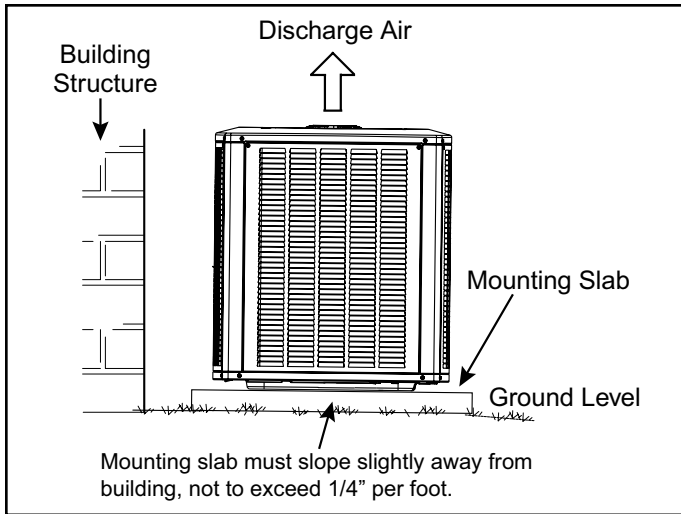

**Figure 2. Slab Mounting**

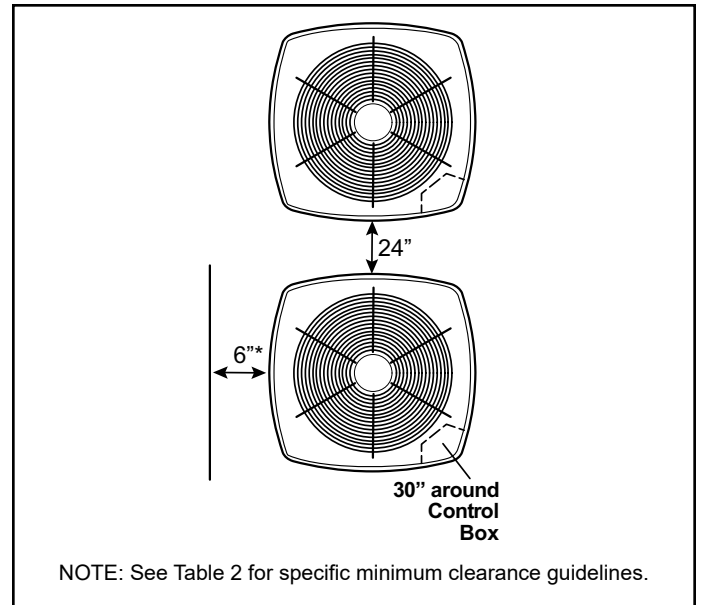

**Figure 3.**

**Elevate Unit**

**⚠ CAUTION**

Accumulation of water and ice in base pan may cause equipment damage.

Elevate unit per local climate and code requirements to provide clearance above estimated snowfall level and ensure adequate drainage of unit. Use snow stand in areas where prolonged freezing temperatures are encountered.

If conditions or local codes require the unit be attached to pad or mounting frame, tie down bolts should be used and fastened through knockouts provided in unit base pan.

**Clearance Requirements**

When installing, allow sufficient space for airflow clearance, wiring, refrigerant piping, and service. For proper airflow, quiet operation and maximum efficiency. Position so water, snow, or ice from roof or eaves cannot fall directly on unit. Refer to Table 2 for installation clearances.

Location	Minimum Clearance
Service box	30"
Top of unit*	48"
Between units	24"
Against wall	6"

\* Maximum soffit overhang is 36".  
**NOTE:** At least one side should be unobstructed by a wall or other barrier.

**Table 2. Clearances**

**DO LOCATE THE UNIT:**

- With proper clearances on sides and top of unit
- On a solid, level foundation or pad (unit must be level to within  $\pm 1/4$  in./ft. per compressor manufacturer specifications)
- To minimize refrigerant line lengths

**DO NOT LOCATE THE UNIT:**

- On brick, concrete blocks or unstable surfaces
- Near clothes dryer exhaust vents where debris accumulates
- Near sleeping area or near windows
- Under eaves where water, snow or ice can fall directly on the unit
- With clearance less than 2 ft. from a second unit
- With clearance less than 4 ft. on top of unit

**Rooftop Installations**

Install unit at a minimum of 6" above surface of the roof to avoid ice buildup around the unit. Locate the unit above a load bearing wall or area of the roof that can adequately support the unit. Consult local codes for rooftop applications.

If unit cannot be mounted away from prevailing winds, a wind barrier should be constructed. Due to variation in installation applications, size and locate barrier according to the best judgment of the installer.

## Torque Requirements

When servicing or repairing heating, ventilating, and air conditioning components, ensure the fasteners are appropriately tightened. Table 3 lists torque values for fasteners.

### IMPORTANT

To prevent stripping of the various caps used, the appropriately sized wrench should be used and fitted snugly over the cap before tightening.

When servicing or repairing HVAC components, ensure the fasteners are appropriately tightened. Table 3 provides torque values for fasteners.

### IMPORTANT

Only use Allen wrenches of sufficient hardness (50Rc - Rockwell Harness Scale minimum). Fully insert the wrench into the valve stem recess.

Service valve stems are factory-torqued (from 9 ft-lbs for small valves, to 25 ft-lbs for large valves) to prevent refrigerant loss during shipping and handling. Using an Allen wrench rated at less than 50Rc risks rounding or breaking off the wrench, or stripping the valve stem recess.

Parts	Recommended Torque	
Service valve cap	8 ft.-lb.	11 NM
Sheet metal screws	16 in.-lb.	2 NM
Machine screws #10	28 in.-lb.	3 NM
Compressor bolts	90 in.-lb.	10 NM
Gauge port seal cap	8 ft.-lb.	11 NM

**Table 3. Torque Requirements**

## Using Manifold Gauge Set

When checking the system charge, only use a manifold gauge set that features low loss anti-blow back fittings. Manifold gauge set used with HFC-410A refrigerant systems must be capable of handling the higher system operating pressures.

The gauges should be rated for use with pressures of 0 - 800 psig on the high side and a low side of 30" vacuum to 250 psig with dampened speed to 500 psi. Gauge hoses must be rated for use at up to 800 psig of pressure with a 4000 psig burst rating.

## Operating Service Valves

The liquid and vapor line service valves are used for removing refrigerant, flushing, leak testing, evacuating, checking charge and charging. Each valve is equipped with a service port which has a factory-installed valve stem.

## Liquid and Suction Line Service Valves

The liquid line and suction line service valves (see Figure 4) and service ports are used for leak testing, evacuation, charging, and checking charge.

Each valve is equipped with a service port which has a factory-installed Schrader valve. A service port cap protects the Schrader valve from contamination and serves as the primary leak seal.

### **To Access the Schrader Port:**

1. Remove the service port cap with an adjustable wrench.
2. Connect gauge to the service port.
3. When testing is completed, replace service port cap. Tighten finger tight, then an additional 1/6 turn.

### **To Open Liquid or Suction Line Service Valve:**

1. Remove stem cap with an adjustable wrench.
2. Use service wrench with a hex-head extension to back the stem out counterclockwise as far as it will go. Use a 3/16" hex head extension for liquid line service valves and a 5/16" extension for suction line service valves.
3. Replace the stem cap. Tighten finger tight, then tighten an additional 1/6 turn.

### **To Close Liquid or Suction Line Service Valve:**

1. Remove the stem cap with an adjustable wrench.
2. Use a service wrench with a hex-head extension to turn the stem clockwise to seat the valve. Tighten firmly.
3. Replace the stem cap. Tighten finger tight, then tighten an additional 1/6 turn.

## Suction Line (Ball Type) Service Valve

Suction line (ball type) service valves function the same way as the other valves; the difference is in the construction (see Figure 5).

The ball valve is equipped with a service port with a factory-installed Schrader valve. A service port cap protects the Schrader valve from contamination and serves as the primary seal.

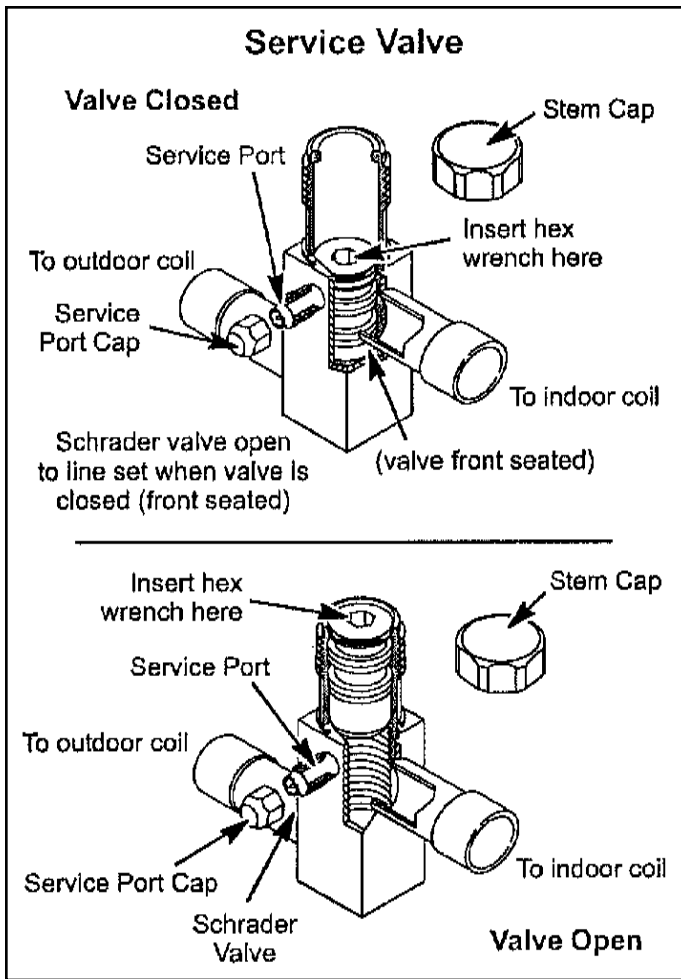

Figure 4.

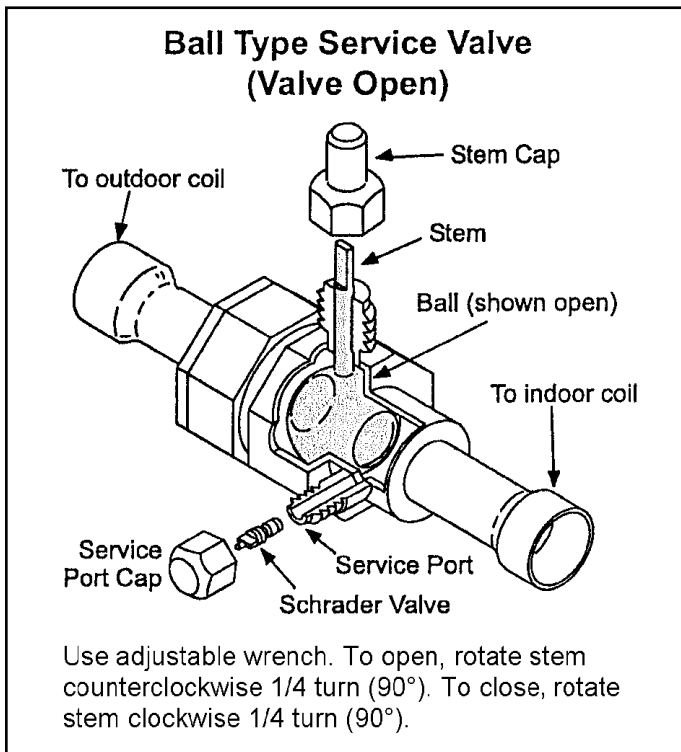

Figure 5.

## Refrigeration Piping

- Use only refrigerant grade copper tubes.
- Split systems may be installed with up to 50 feet of line set (no more than 20 feet vertical) without special consideration (see long line set guidelines).
- Ensure that vapor and liquid tube diameters are appropriate to capacity of unit.
- Run refrigerant tubes as directly as possible by avoiding unnecessary turns and bends.
- When passing refrigerant tubes through the wall, seal opening with RTV or other silicon-based caulk.
- Avoid direct tubing contact with water pipes, duct work, floor joists, wall studs, floors, walls, and any structure.
- Do not suspend refrigerant tubing from joists and studs with a rigid wire or strap that comes in direct contact with tubing.
- Ensure that tubing insulation is pliable and completely surrounds vapor tube.

It is important that no tubing be cut or seals broken until you are ready to actually make connections to the evaporator and to the condenser section. DO NOT remove rubber plugs or copper caps from the tube ends until ready to make connections at evaporator and condenser. Under no circumstances leave the lines open to the atmosphere for any period of time, if so unit requires additional evacuation to remove moisture.

Model	14/16 SEER	
	Liquid Line	Suction Line
18	3/8	3/4
24	3/8	3/4
30	3/8	3/4
36	3/8	7/8
41	3/8	7/8
42	3/8	7/8
47	3/8	7/8
48	3/8	7/8
59	3/8	1-1/8
60	3/8	1-1/8

\* Fittings should be supplied by the installer.

Table 4.

Be extra careful with sharp bends. Tubing can “kink” very easily, and if this occurs, the entire tube length will have to be replaced. Extra care at this time will eliminate future service problems.

# LINE SET

**IMPORTANT** — Refrigerant lines must not contact structure.

## INSTALLATION

**Line Set Isolation** — The following illustrations are examples of proper refrigerant line set isolation:

### REFRIGERANT LINE SET — TRANSITION FROM VERTICAL TO HORIZONTAL

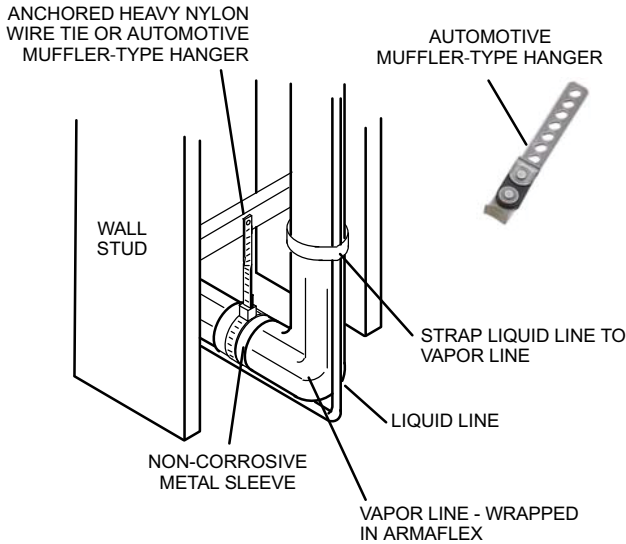

### REFRIGERANT LINE SET — INSTALLING VERTICAL RUNS (NEW CONSTRUCTION SHOWN)

**NOTE** — Insulate liquid line when it is routed through areas where the surrounding ambient temperature could become higher than the temperature of the liquid line or when pressure drop is equal to or greater than 20 psig.

**IMPORTANT** — Refrigerant lines must not contact wall

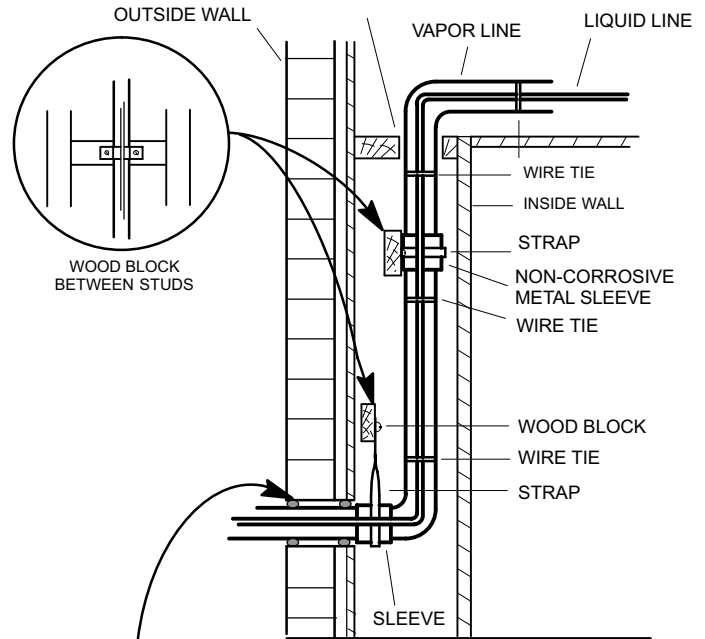

### REFRIGERANT LINE SET — INSTALLING HORIZONTAL RUNS

To hang line set from joist or rafter, use either metal strapping material or anchored heavy nylon wire ties.

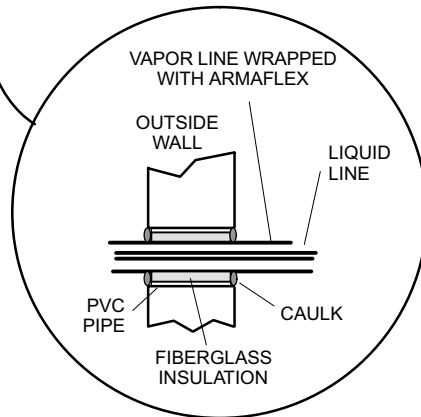
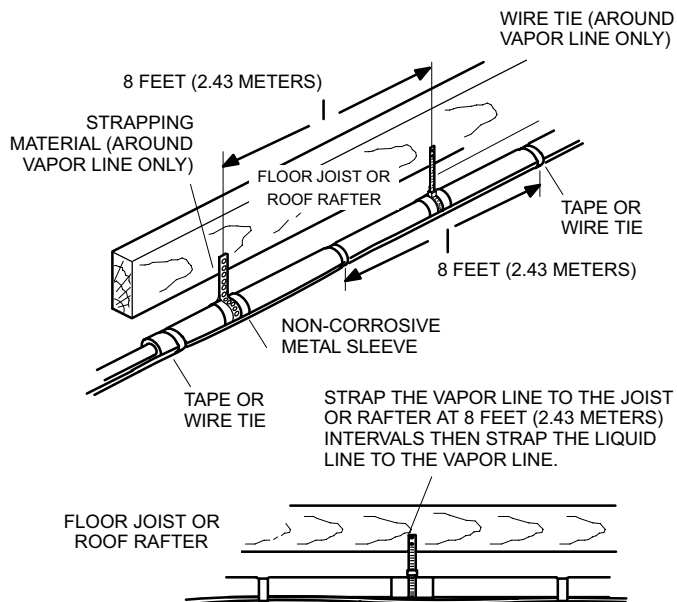

**NOTE** — Similar installation practices should be used if line set is to be installed on exterior of outside wall.

It is recommended that vertical suction risers not be up-sized. Proper oil return to the compressor should be maintained with suction gas velocity.

### Filter Drier

The filter drier is very important for proper system operation and reliability. If the drier is shipped loose, it must be installed by the installer in the field. Unit warranty will be void, if the drier is not installed.

### Installation of Line Sets

**DO NOT** fasten liquid or suction lines in direct contact with the floor or ceiling joist. Use an insulated or suspension type of hanger. Keep both lines separate, and always insulate the suction line. Liquid line runs (30 feet or more) in an attic will require insulation. Route refrigeration line sets to minimize length.

**DO NOT** let refrigerant lines come in direct contact with foundation. When running refrigerant lines through the foundation or wall, openings should allow for a sound and vibration absorbing material to be placed or installed between tubing and foundation. Any gap between foundation or wall and refrigerant lines should be filled with a vibration damping material.

### CAUTION

If ANY refrigerant tubing is required to be buried by state or local codes, provide a 6 inch vertical rise at service valve.

### Installation into an Existing R-22 System

If the unit will be installed in an existing system that uses an indoor unit or line sets charged with R-22 refrigerant, installer must perform the following procedures to convert the system to an R-410A system.

### Remove Existing Expansion Valve

1. On fully cased coils, remove the coil access and plumbing panels.
2. Remove any shipping clamps from the liquid line and distributor assembly.
3. Disconnect the equalizer line from the check expansion valve equalizer line fitting on the vapor line.
4. Remove the vapor line sensing bulb.
5. Disconnect the liquid line from the check expansion valve at the liquid line assembly.
6. Disconnect the check expansion valve from the liquid line orifice housing. Take care not to twist or damage distributor tubes during this process.
7. Remove and discard check expansion valve and the two Teflon® rings (see Figure 6).
8. Use a field-provided fitting to temporarily reconnect the liquid line to the indoor unit's liquid line orifice housing.

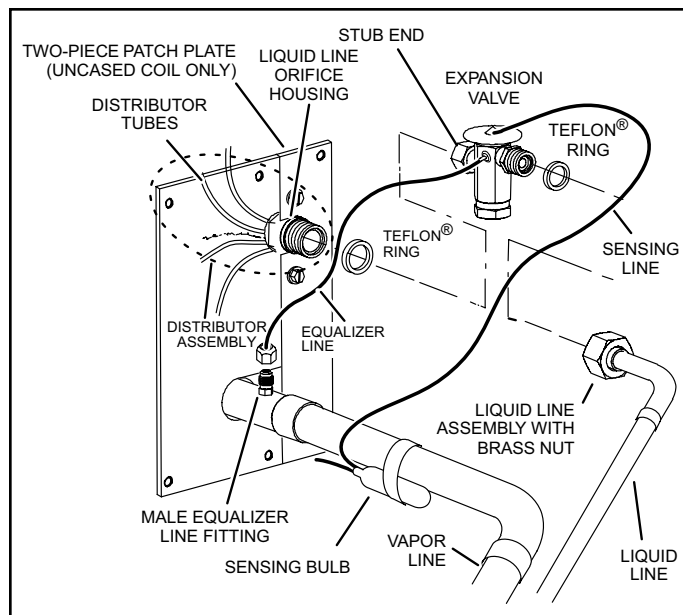

**Figure 6. Remove Existing Expansion Valve (uncased coil shown)**

### Flushing Line Sets

If the unit will be installed in an existing system that uses an indoor unit or line sets charged with R-22 refrigerant, installer must perform the following flushing procedure.

**NOTE:** Existing system components (including line set and indoor coil) must be an AHRI match with the unit in order to fulfill unit warranty requirements.

### WARNING

Refrigerant must be reclaimed in accordance with national and local codes.

### CAUTION

Do **NOT** attempt to flush and re-use existing line sets or indoor coil when the system contains contaminants (i.e., compressor burn out).

### NOTE

“Clean refrigerant” is any refrigerant in a system that has not had compressor burnout. If the system has experienced burnout, it is recommended that the existing line set and indoor coil be replaced.

### NOTE

In lieu of R-410A, an industry-standard flushing agent may also be used.

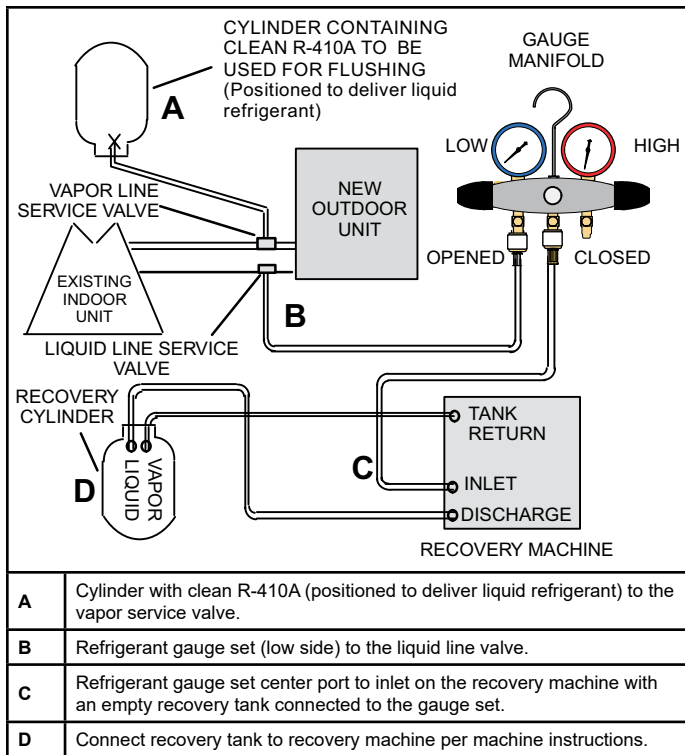

**Figure 7.**

1. Connect gauges and equipment as shown in Figure 7.
2. Set the recovery machine for liquid recovery and start the recovery machine. Open the gauge set valves to allow the recovery machine to pull a vacuum on the existing system line set and indoor unit coil.
3. Position the cylinder of clean R-410A for delivery of liquid refrigerant and open its valve to allow liquid refrigerant to flow into the system through the vapor line valve. Allow the refrigerant to pass from the cylinder and through the line set and the indoor unit coil before it enters the recovery machine.
4. After all of the liquid refrigerant has been recovered, switch the recovery machine to vapor recovery so that all of the R-410A vapor is recovered. Allow the recovery machine to pull the system down to 0.
5. Close the valve on the inverted R-410A drum and the gauge set valves. Pump the remaining refrigerant out of the recovery machine and turn the machine off.

## Refrigerant Piping - Install Indoor Expansion Valve

This outdoor unit is designed for use in systems that include an expansion valve metering device (purchased separately) at the indoor coil. See the Product Specifications for approved expansion valve kit match-ups and application information. The check expansion valve unit can be installed internal or external to the indoor coil. In applications where an uncased coil is being installed in a field-provided plenum, install the check/expansion valve in a manner that will provide access for future field service of the expansion valve. Refer to below illustration for reference during installation of expansion valve unit.

### INDOOR EXPANSION VALVE INSTALLATION

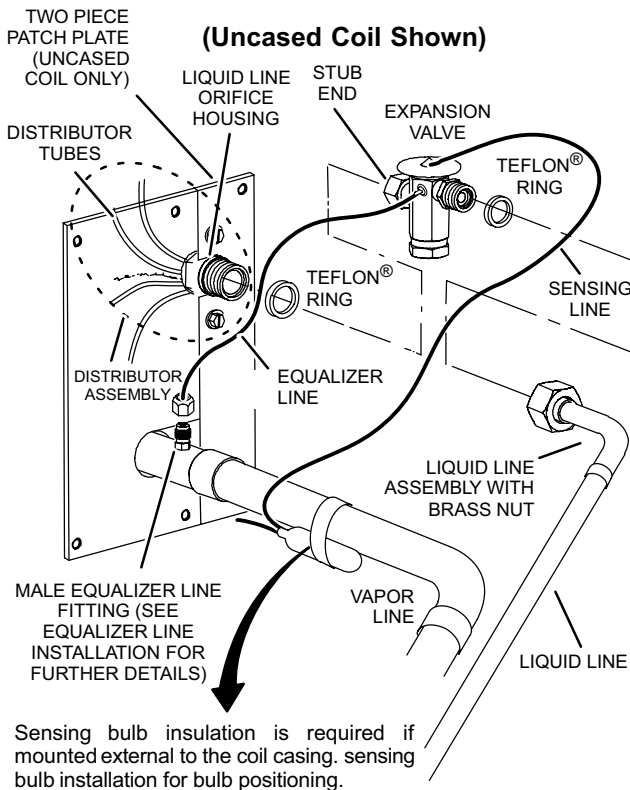

- 3 - Install one of the provided Teflon® rings around the stubbed end of the check expansion valve and lightly lubricate the connector threads and expose surface of the Teflon® ring with refrigerant oil.
- 4 - Attach the stubbed end of the check expansion valve to the liquid line orifice housing. Finger tighten and use an appropriately sized wrench to turn an additional 1/2 turn clockwise as illustrated in the figure above, or tighten to 20 ft-lb.
- 5 - Place the remaining Teflon® washer around the other end of the check expansion valve. Lightly lubricate connector threads and expose surface of the Teflon® ring with refrigerant oil.
- 6 - Attach the liquid line assembly to the check expansion valve. Finger tighten and use an appropriately sized wrench to turn an additional 1/2 turn clockwise as illustrated in the figure above or tighten to 20 ft-lb.

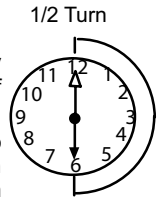

### SENSING BULB INSTALLATION

- 1 - Attach the vapor line sensing bulb in the proper orientation as illustrated to the right using the clamp and screws provided.

**NOTE** - Though it is preferred to have the sensing bulb installed on a horizontal run of the vapor line, installation on a vertical run of piping is acceptable if necessary.

**NOTE** - Confirm proper thermal contact between vapor line and check/expansion bulb before insulating the sensing bulb once installed.

- 2 - Connect the equalizer line from the check expansion valve to the equalizer vapor port on the vapor line. Finger tighten the flare nut plus 1/8 turn (7 ft-lbs) as illustrated below.

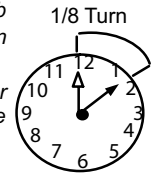

### EQUALIZER LINE INSTALLATION

- 1 - Remove and discard either the flare seal cap or flare nut with copper flare seal bonnet from the equalizer line port on the vapor line as illustrated in the figure below.
- 2 - Remove the field-provided fitting that temporarily reconnected the liquid line to the indoor unit's distributor assembly.

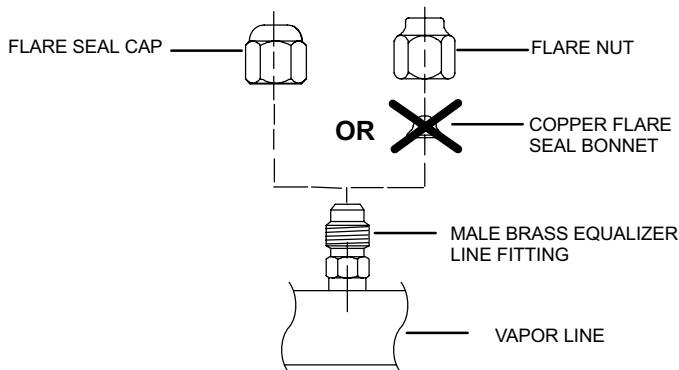

ON LINES SMALLER THAN 7/8", MOUNT SENSING BULB AT EITHER THE 3 OR 9 O'CLOCK POSITION.

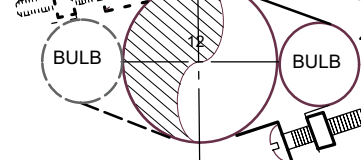

ON 7/8" AND LARGER LINES, MOUNT SENSING BULB AT EITHER THE 4 OR 8 O'CLOCK POSITION.

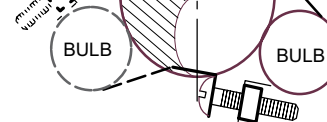

**NOTE** - NEVER MOUNT THE SENSING BULB ON BOTTOM OF LINE.

# Refrigerant Piping - Brazing Procedures

## 1 CUT AND DEBUR

Cut ends of the refrigerant lines square (free from nicks or dents) and debur the ends. The pipe must remain round. Do not crimp end of the line.

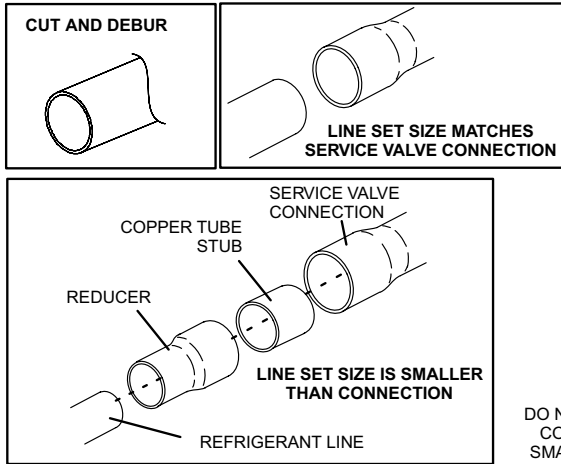

## 2 CAP AND CORE REMOVAL

Remove service cap and core from both the vapor and liquid line service ports.

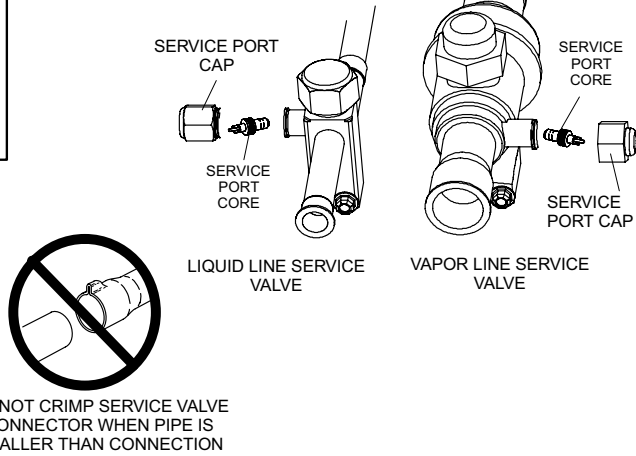

## 3 ATTACH THE MANIFOLD GAUGE SET FOR BRAZING LIQUID AND VAPOR LINE SERVICE VALVES

Flow regulated nitrogen (at 1 to 2 psig) through the low-side refrigeration gauge set into the liquid line service port valve, and out of the vapor line service port valve.

- A - Connect gauge set low pressure side to liquid line service valve (service port).
- B - Connect gauge set center port to bottle of nitrogen with regulator.
- C - Remove core from valve in vapor line service port to allow nitrogen to escape.

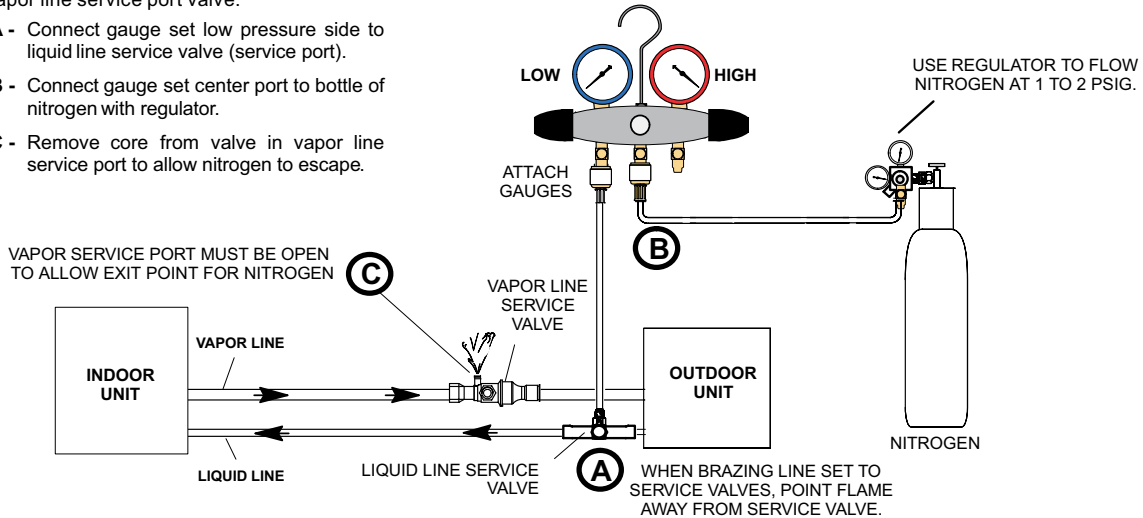

### NOTE

Use a manifold gauge set designed for use on R-410A refrigerant systems.

### ⚠ WARNING

Before brazing, ensure the system is fully recovered of all refrigerant. Application of a brazing torch to a pressurized system may result in ignition of the refrigerant and oil mixture. Check the high and low pressures before applying heat.



### ⚠ WARNING

Brazing alloys and flux contain materials which are hazardous to your health.

Avoid breathing vapors or fumes from brazing operations. Perform operations only in well-ventilated areas.

Wear gloves and protective goggles or face shield to protect against burns.

Wash hands with soap and water after handling brazing alloys and flux.



## 4 WRAP SERVICE VALVES

To help protect service valve seals during brazing, wrap water-saturated cloths around service valve bodies and copper tube stubs. Use additional water-saturated cloths underneath the valve body to protect the base paint.

## 5 FLOW NITROGEN

Flow regulated nitrogen (at 1 to 2 psig) through the refrigeration gauge set into the valve stem port connection on the liquid service valve and out of the vapor valve stem port. See steps 3A, 3B and 3C on manifold gauge set connections.

## 6 BRAZE LINE SET

Wrap both service valves with water-saturated cloths as illustrated here and as mentioned in step 4, before brazing to line set. Cloths must remain water-saturated throughout the brazing and cool-down process.

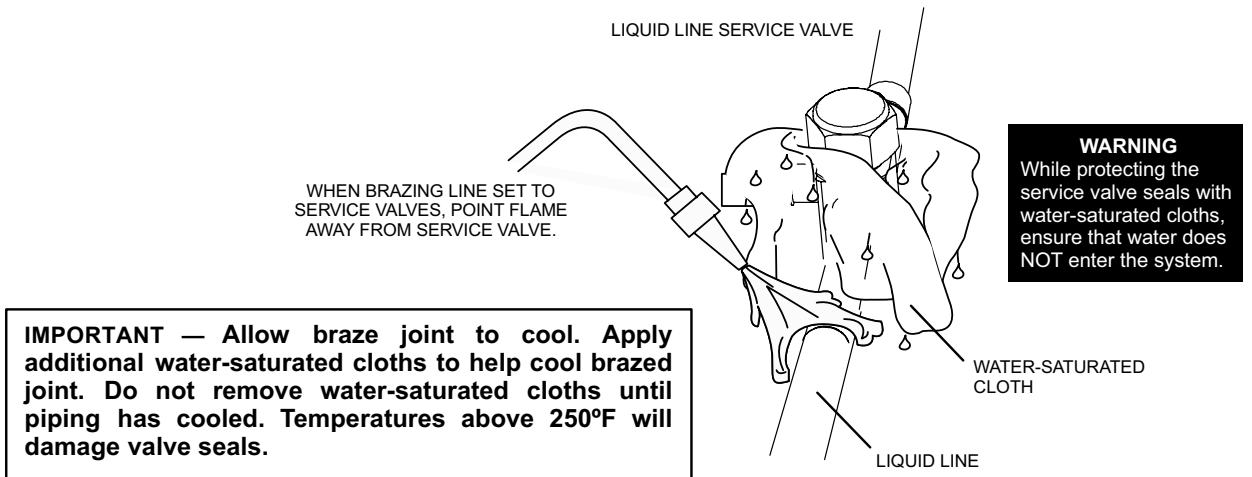

### WARNING

**FIRE, PERSONAL INJURY, OR PROPERTY DAMAGE** may result if you do not wrap a water-saturated cloth around both liquid and suction line service valve bodies and copper tube stub while brazing the line set! The braze, when complete, must be quenched with water to absorb any residual heat.

Do not open service valves until refrigerant lines and indoor coil have been leak-tested and evacuated. Refer to Leak Test and Evacuation section of this manual.

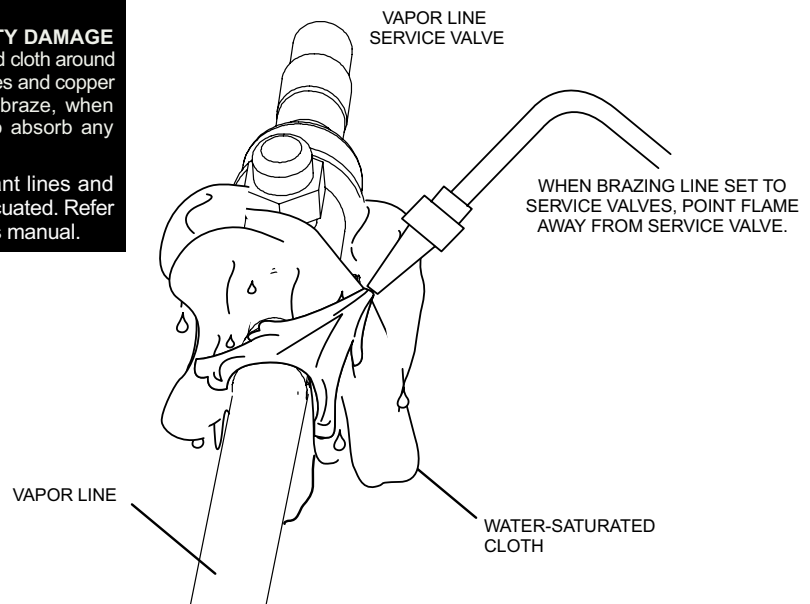

## 7 PREPARATION FOR NEXT STEP

After all connections have been brazed, disconnect manifold gauge set from service ports. Apply additional water-saturated cloths to both services valves to cool piping. Once piping is cool, remove all water-saturated cloths.

## Leak Test and Evacuation

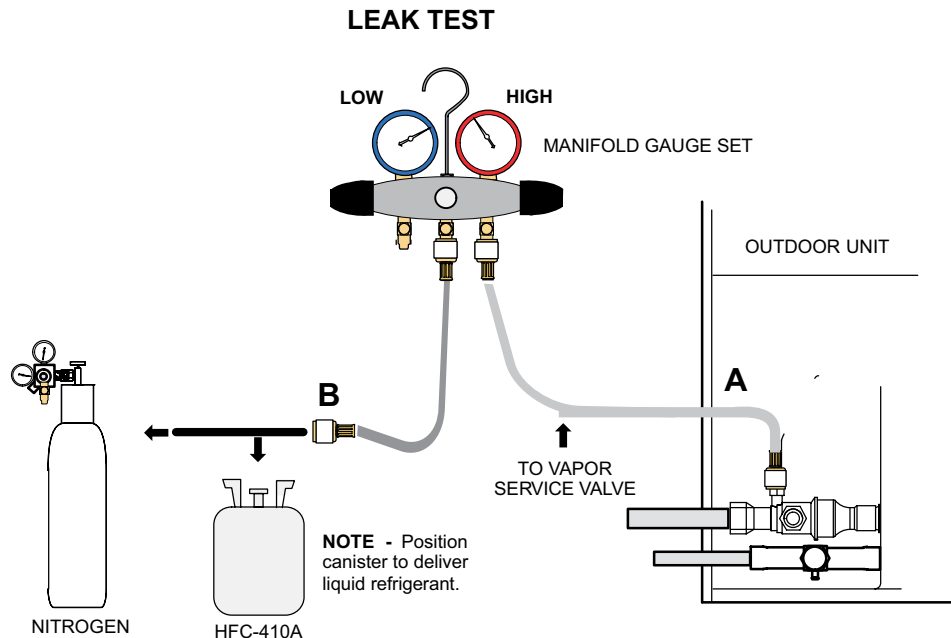

### 1 CONNECT GAUGE SET

- A** - Connect the high pressure hose of an HFC-410A manifold gauge set to the vapor valve service port.  
**NOTE** - Normally, the high pressure hose is connected to the liquid line port. However, connecting it to the vapor port better protects the manifold gauge set from high pressure damage.
- B** - With both manifold valves closed, connect the cylinder of HFC-410A refrigerant to the center port of the manifold gauge set.  
**NOTE** - Later in the procedure, the HFC-410A container will be replaced by the nitrogen container.

### 2 TEST FOR LEAKS

After the line set has been connected to the indoor and outdoor units, check the line set connections and indoor unit for leaks. Use the following procedure to test for leaks:

- A** - With both manifold valves closed, connect the cylinder of HFC-410A refrigerant to the center port of the manifold gauge set. Open the valve on the HFC-410A cylinder (vapor only).
- B** - Open the high pressure side of the manifold to allow HFC-410A into the line set and indoor unit. Weigh in a trace amount of HFC-410A. [A trace amount is a maximum of two ounces (57 g) refrigerant or three pounds (31 kPa) pressure.] Close the valve on the HFC-410A cylinder and the valve on the high pressure side of the manifold gauge set. Disconnect the HFC-410A cylinder.
- C** - Connect a cylinder of nitrogen with a pressure regulating valve to the center port of the manifold gauge set.
- D** - Adjust nitrogen pressure to 150 psig (1034 kPa). Open the valve on the high side of the manifold gauge set in order to pressurize the line set and the indoor unit.
- E** - After a few minutes, open one of the service valve ports and verify that the refrigerant added to the system earlier is measurable with a leak detector.
- F** - After leak testing, disconnect gauges from service ports.  
**NOTE** - Service valve cores remain removed for the following evacuation procedure.

### 3 CONNECT GAUGE SET

**NOTE** - Remove cores from service valves (if not already done).

- A - Connect low side of manifold gauge set with 1/4 SAE in-line tee to vapor line service valve
- B - Connect high side of manifold gauge set to liquid line service valve
- C - Connect available micron gauge connector on the 1/4 SAE in-line tee.
- D - Connect the vacuum pump (with vacuum gauge) to the center port of the manifold gauge set. The center port line will be used later for both the HFC-410A and nitrogen containers.

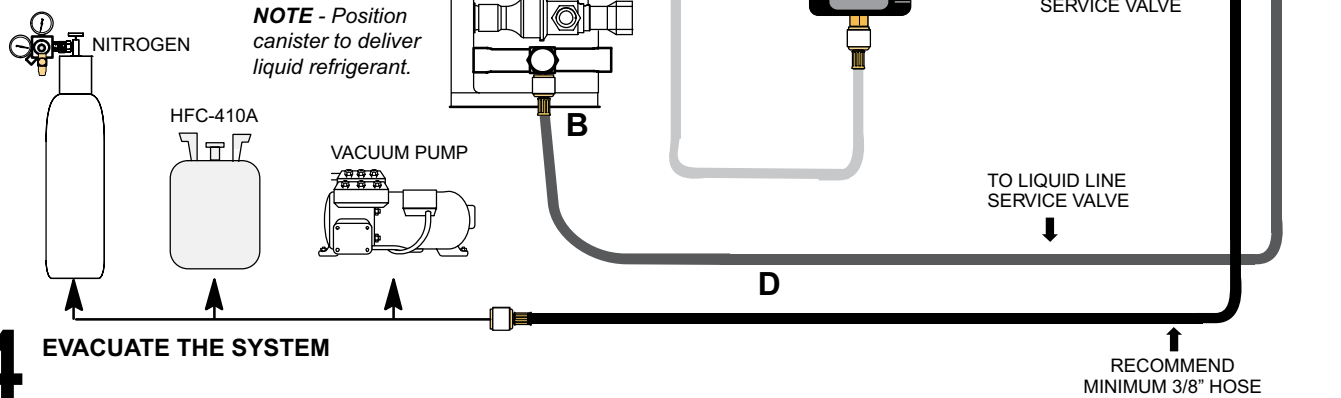

### 4 EVACUATE THE SYSTEM

- A - Open both manifold valves and start the vacuum pump.
- B - Evacuate the line set and indoor unit until a slight vacuum is indicated on the micron gauge (approximately 23,000 microns or 29.01 inches of mercury).
  - NOTE** - During the early stages of evacuation, it is desirable to close the manifold gauge valve at least once. A rapid rise in pressure indicates a relatively large leak. If this occurs, **repeat the leak testing procedure**.
  - NOTE** - The term **absolute pressure** means the total actual pressure above absolute zero within a given volume or system. Absolute pressure in a vacuum is equal to atmospheric pressure minus vacuum pressure.
- C - When the absolute pressure reaches 23,000 microns (29.01 inches of mercury), perform the following:
  - Close manifold gauge valves.
  - Close valve on vacuum pump.
  - Turn off vacuum pump.
  - Disconnect manifold gauge center port hose from vacuum pump.
  - Attach manifold center port hose to a nitrogen cylinder with pressure regulator set to 150 psig (1034 kPa) and purge the hose.
  - Open manifold gauge valves to break the vacuum in the line set and indoor unit.
  - Close manifold gauge valves.
- D - Shut off the nitrogen cylinder and remove the manifold gauge hose from the cylinder. Open the manifold gauge valves to release the nitrogen from the line set and indoor unit.
- E - Reconnect the manifold gauge to the vacuum pump, turn the pump on, and continue to evacuate the line set and indoor unit until the absolute pressure does not rise above 500 microns (29.9 inches of mercury) within a 20-minute period after shutting off the vacuum pump and closing the manifold gauge valves.
- F - When the absolute pressure requirement above has been met, disconnect the manifold hose from the vacuum pump and connect it to a cylinder of HFC-410A positioned to deliver liquid refrigerant. Open the manifold gauge valve 1 to 2 psig in order to release the vacuum in the line set and indoor unit.
- G - Perform the following:
  - Close manifold gauge valves.
  - Shut off HFC-410A cylinder.
  - Reinstall service valve cores by removing manifold hose from service valve. Quickly install cores with core tool while maintaining a positive system pressure.
  - Replace stem caps and finger tighten them, then tighten an additional one-sixth (1/6) of a turn as illustrated.
- H - Open suction service valve first before liquid valve to release the unit charge into the system. Replace valve caps and tighten (8 ft. lb.). Caps are the primary seal.

**WARNING !**

**Possible equipment damage.**

**Avoid deep vacuum operation. Do not use compressors to evacuate a system. Extremely low vacuum can cause internal arcing and compressor failure. Damage caused by deep vacuum operation will void warranty.**

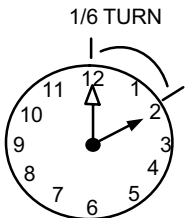

## Electrical Wiring

All field wiring must be done in accordance with the National Electrical Code (NEC) recommendations, Canadian Electrical Code (CEC) and CSA Standards, or local codes, where applicable.

### **⚠ WARNING**

#### **Electrical Shock Hazard!**



Turn OFF electric power before connecting unit, performing any maintenance or removing panels or doors. More than one disconnect may be required to turn off all power.

**FAILURE TO DO SO COULD RESULT IN BODILY INJURY OR DEATH.**

### **⚠ WARNING**

Unit must be grounded in accordance with national and local codes. Failure to ground unit properly can result in personal injury or death.

### **⚠ WARNING**

Line voltage is present at all components when unit is not in operation on units with single pole contactors. Disconnect all remote electric power supplies before opening access panel. Unit may have multiple power supplies. Failure to disconnect all power supplies could result in personal injury or death.

Refer to the furnace or blower coil Installation Instructions for additional wiring application diagrams and refer to unit rating plate for minimum circuit ampacity and maximum overcurrent protection size.

1. Install line voltage power supply to unit from a properly sized disconnect switch. Any excess high voltage field wiring should be trimmed or secured away from the low voltage field wiring.
2. High voltage power connections to 3-phase models is made to "Pig Tail" leads with field supplied splice connectors.

3. Ground unit at unit disconnect switch or to an earth ground. To facilitate conduit, a hole is in the bottom of the control box. Connect conduit to the control box using a proper conduit fitting. Units are approved for use only with copper conductors. 24V Class II circuit connections are made in the low voltage junction box. A complete unit wiring diagram is located inside the unit control box cover.
4. Install room thermostat according to thermostat installation instruction and on an inside wall that is not subject to drafts, direct sunshine, or other heat sources.
5. Install low voltage wiring from outdoor to indoor unit and from thermostat to indoor unit (see Figure 8).
6. Do not bundle any excess 24V control wire inside control box. Run control wire through installed wire tie and tighten wire tie to provide low voltage strain relief and to maintain separation of field-installed low and high voltage circuits.

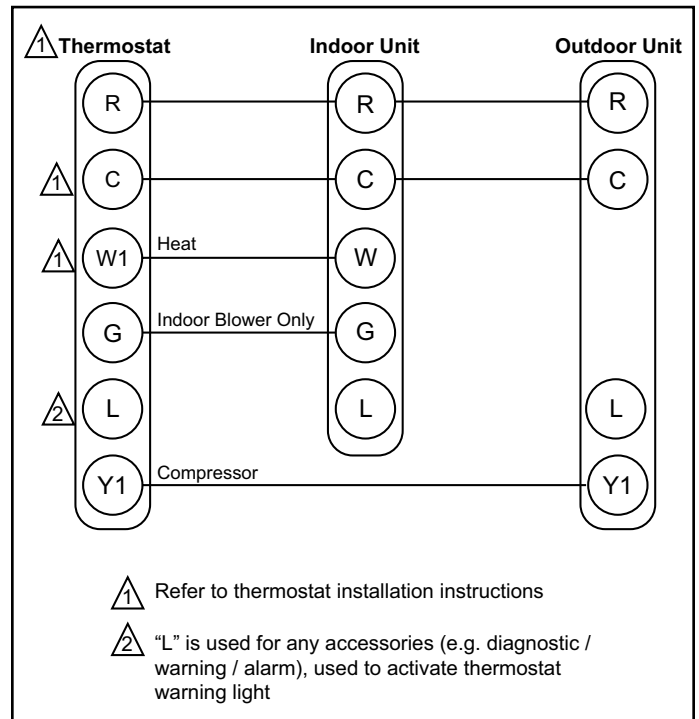

**Figure 8. Thermostat Designations - Non-Communicating**

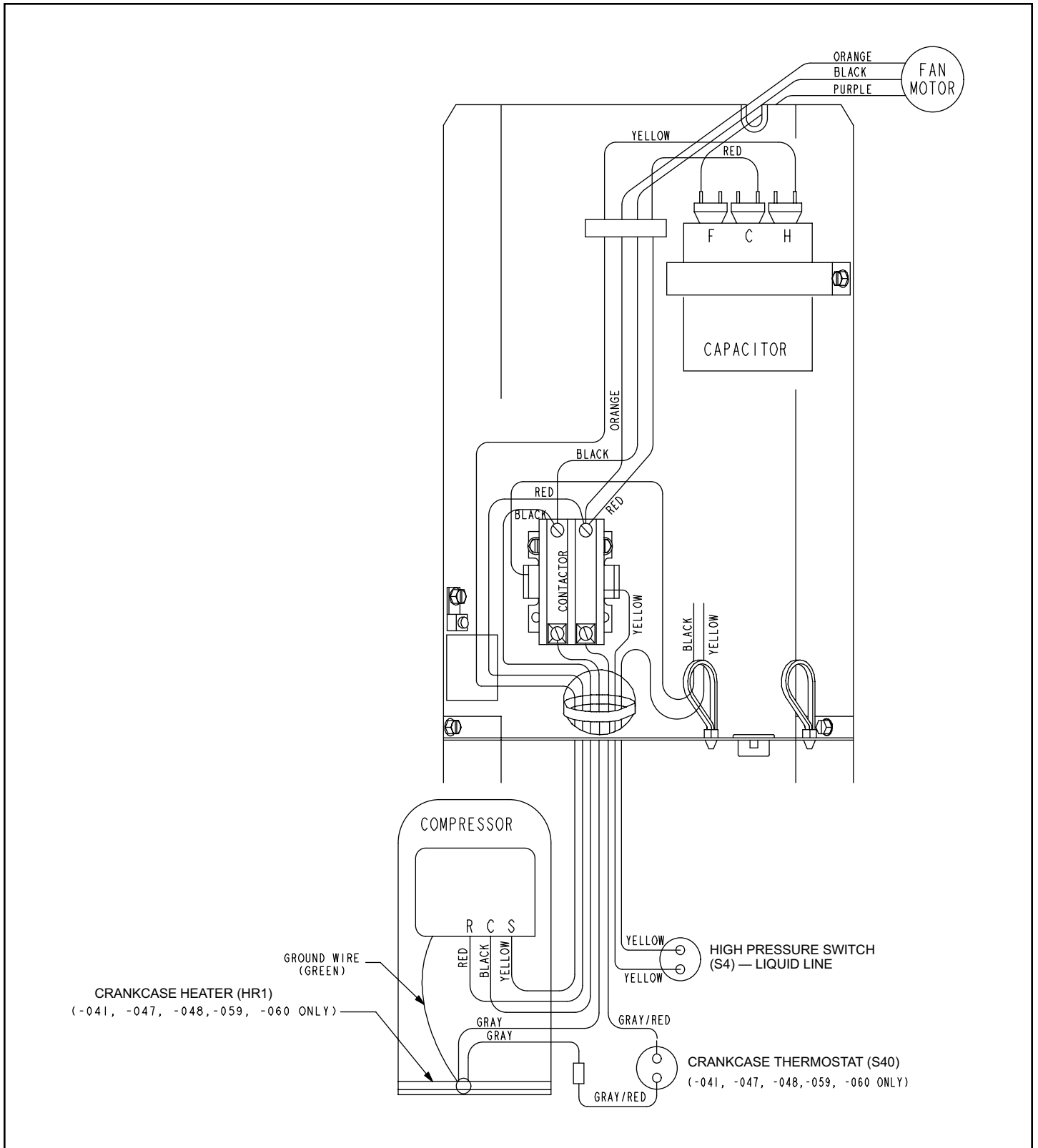

**Figure 9. Typical Factory Wiring Diagram (Copeland Compressor)**

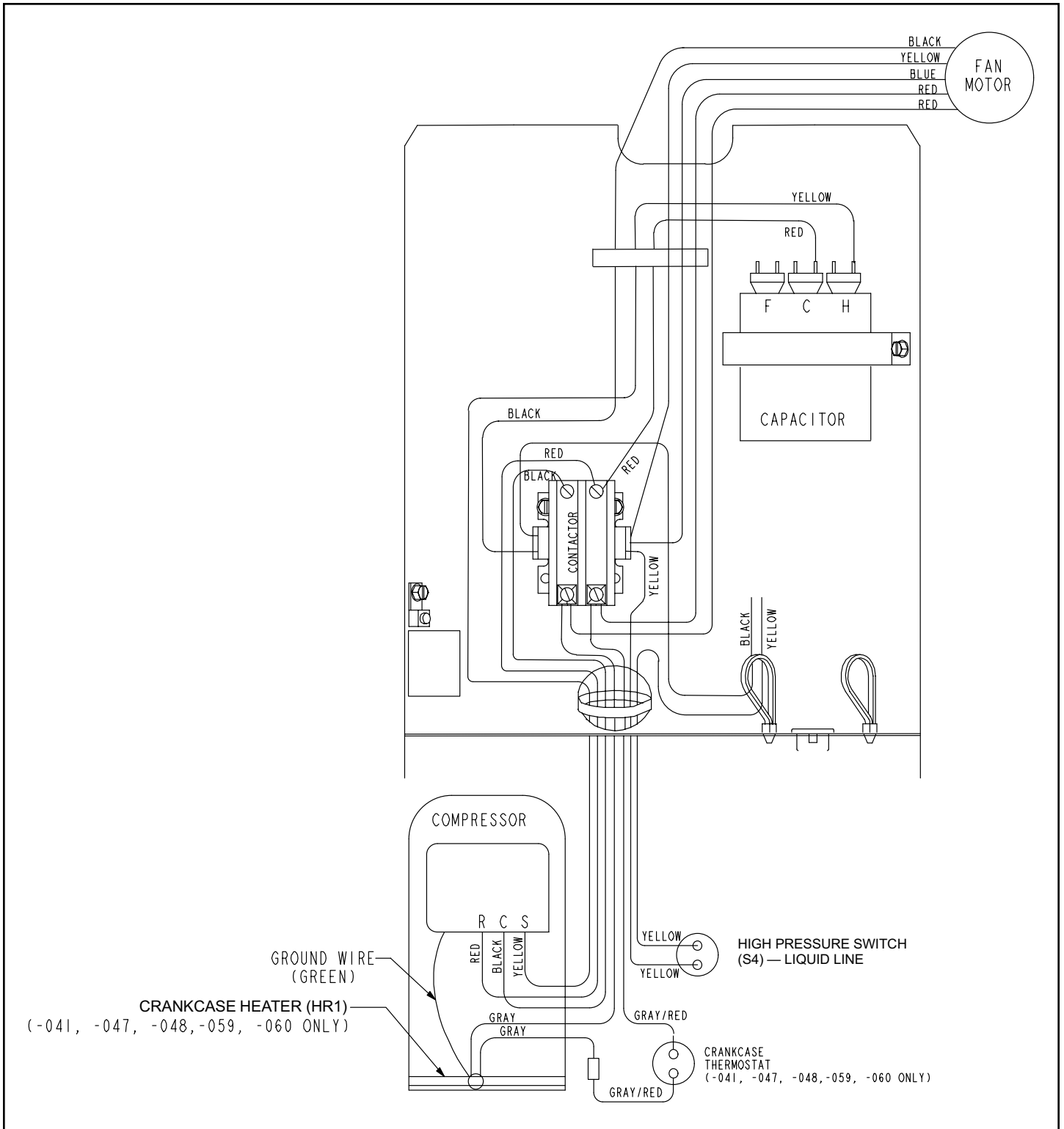

**Figure 10. Typical Factory Wiring Diagram (Copeland Compressor) (59 model only)**

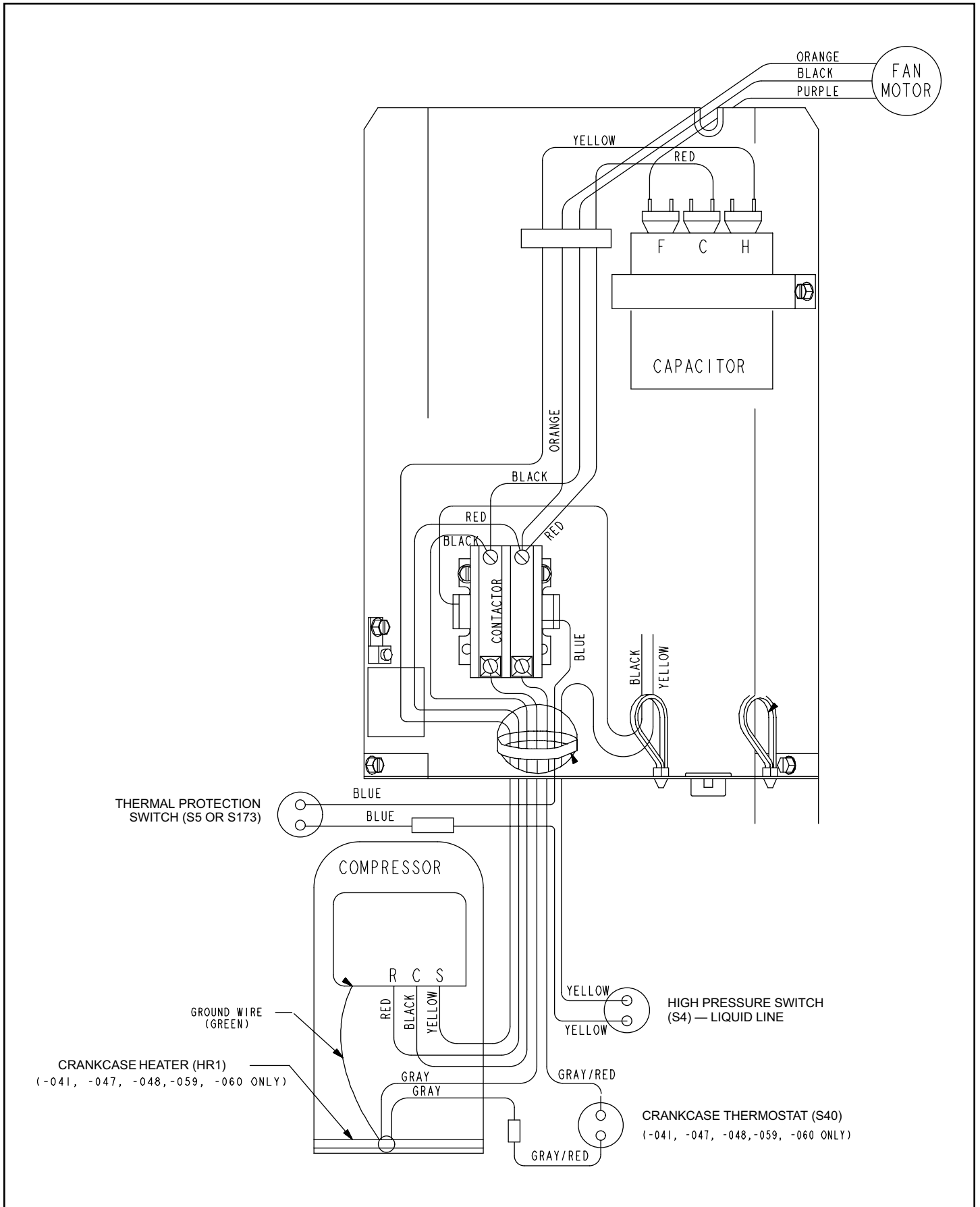

**Figure 11. Typical Factory Wiring Diagram (Interlink Compressor)**

## Sequence of Operation

**NOTE:** The thermostat used may be electromechanical or electronic.

**NOTE:** Transformer in indoor unit supplies power (24 VAC) to the thermostat and outdoor unit controls.

### Cooling:

1. Cooling demand initiates at Y1 in the thermostat.
2. 24VAC from indoor unit (Y1) energizes the TOC timed off control (if used) which energizes contactor K1 (provided S4 high pressure switch is closed).
3. K1-1 N.O. closes, energizing compressor (B1) and outdoor fan motor (B4).
4. Compressor (B1) and outdoor fan motor (B4) begin immediate operation..

### End of Cooling Demand:

5. Cooling demand is satisfied. Terminal Y1 is de-energized.
6. Compressor contactor K1 is de-energized.
7. K1-1 opens and compressor (B1) and outdoor fan motor (B4) are de-energized and stop immediately.

## Start-Up

### CAUTION

If unit is equipped with a crankcase heater, it should be energized 24 hours before unit start-up to prevent compressor damage as a result of slugging.

1. Rotate fan to check for frozen bearings or binding.
2. Inspect all factory and field-installed wiring for loose connections.
3. After evacuation is complete, open liquid line and suction line service valves to release refrigerant charge (contained in outdoor unit) into system.
4. Replace the stem caps and secure finger tight, then tighten an additional 1/6 of a turn.
5. Check voltage supply at the disconnect switch. The voltage must be within the range listed on the unit nameplate. If not, do not start equipment until the power company has been consulted and the voltage condition corrected.
6. Set thermostat for cooling demand, turn on power to indoor blower, and close the outdoor unit disconnect switch to start the unit.
7. Recheck unit voltage with unit running. Power must be within range shown on unit nameplate.

## Refrigerant Charging

### CAUTION

Excessive amounts of liquid refrigerant entering the suction line can damage the compressor. When adding refrigerant, precautions must be taken to control the flow of liquid into the system. This can be done by using a liquid vaporizing adapter or manual control using a sight glass as indicator.

Units are factory charged with the amount of R-410A refrigerant indicated on the unit rating plate. This charge is based on a matching indoor coil and outdoor coil with 15' line set. For varying lengths of line set, refer to Table 5 for refrigerant charge adjustment. A blank space is provided on the unit rating plate to list the actual field charge.

Liquid Line Set Diameter	Oz. Per 5 ft. adjust from 15 ft. line set*
3/8 in.	3 oz. per 5 ft. or 0.6 oz. per 1 ft.
* If line length is greater than 15 ft., add this amount. If line length is less than 15 ft., remove this amount.	

**Table 5. Refrigerant Charge Adjustment**

### IMPORTANT

Mineral oils are not compatible with R-410A. If oil must be added, it must be a polyolester oil.

**NOTE:** Both airflow and refrigerant charge must be monitored for proper system set-up. It may be necessary to alternately check and adjust the airflow and the refrigerant charge.

If the system is void of refrigerant, or if the outdoor ambient temperature is cool, use the weigh-in method to charge the unit. Do this after any leaks have been repaired.

1. Recover the refrigerant from the unit.
2. Conduct a leak check, then evacuate as previously outlined.
3. Weigh in the charge according to the total amount shown on the unit nameplate.

If weighing facilities are not available or if unit is being charged during warm weather, use one of the following procedures.

- **For systems using a fixed orifice on the indoor evaporator and outdoor temperatures above 65°F** – charge using the superheat method and table provided on the unit access panel.
- **For systems using a TXV on the indoor evaporator and outdoor temperature above 60°F** – charge in



cooling mode using the subcooling method and table provided on the unit access panel.

- **For systems below 60°F** – charge in heating mode using the subcooling method and table provided on the unit access panel. Attach low pressure gauge hose to auxiliary service port to access suction side in heating mode.

**NOTE:** All unit table values are based on 70 to 80°F indoor return air temperature for cooling mode, and 65°F to 75°F return air temperature for heat mode.

## Maintenance

### Regular Maintenance Requirements

Your system should be regularly inspected by a qualified service technician. These regular visits may include (among other things) checks for:

- Motor operation
- Ductwork air leaks
- Coil & drain pan cleanliness (indoor & outdoor)
- Electrical component operation & wiring check
- Proper refrigerant level & refrigerant leaks
- Proper airflow
- Drainage of condensate
- Air filter(s) performance
- Blower wheel alignment, balance & cleaning
- Primary & secondary drain line cleanliness

### Air Filter

Inspect air filters at least monthly and replace or clean as required. Disposable filters should be replaced. Washable filters may be cleaned by soaking in mild detergent and rinsing with cold water. Allow filter to dry before reinstalling. Replace filters with the arrows pointing in the direction of airflow. Dirty filters are the most common cause of poor heating / cooling performance and compressor failures.

### Indoor Coil

If the system has been operated with a clean filter in place, it should require minimal cleaning. If cleaning is needed, call your dealer for service.

### Condensate Drain

During cooling season check at least monthly for free flow of drainage and clean if necessary.

### Condenser Coils

Grass cuttings, leaves, dirt, dust, lint from clothes dryers, and foliage from trees can be drawn into coils by movement of the air. Clogged condenser coils will lower the efficiency of your unit and could cause damage to the condenser.

Periodically, debris should be brushed from the condenser coils. Use a soft bristle brush with light pressure only. DO NOT damage or bend condenser coil fins. Damaged or bent fins may affect unit operation.

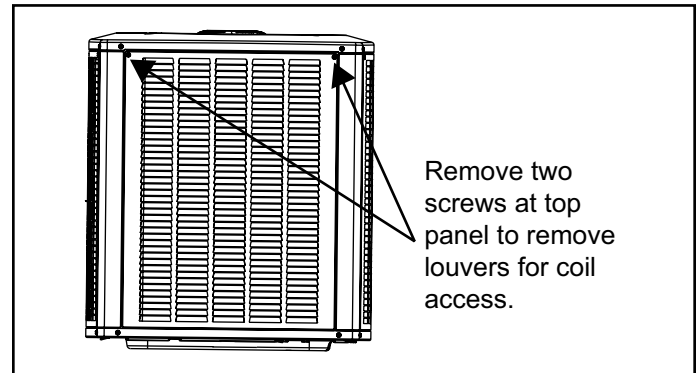

Figure 12. Removing Louvers

### ⚠ WARNING

#### SHARP OBJECT HAZARD!

Condenser coils have sharp edges. Wear adequate body protection on body extremities (e.g. gloves).

**FAILURE TO FOLLOW THIS WARNING COULD RESULT IN BODILY INJURY.**

### Painted Surfaces

For maximum protection of the unit's finish, a good grade of automobile wax should be applied every year. In geographical areas where water has a high concentration of minerals (calcium, iron, sulfur, etc.), it is recommended that lawn sprinklers not be allowed to spray the unit. In such applications, the sprinklers should be directed away from the unit. Failure to follow this precaution may result in premature deterioration of the unit finish and metal components.

In sea coast areas, special maintenance is required due to the corrosive atmosphere provided by the high salt concentration in ocean mists and the air. Periodic washing of all exposed surfaces and coil will add additional life to your unit. Please consult your installing dealer for proper procedures in your geographic area.

# Wiring Diagram

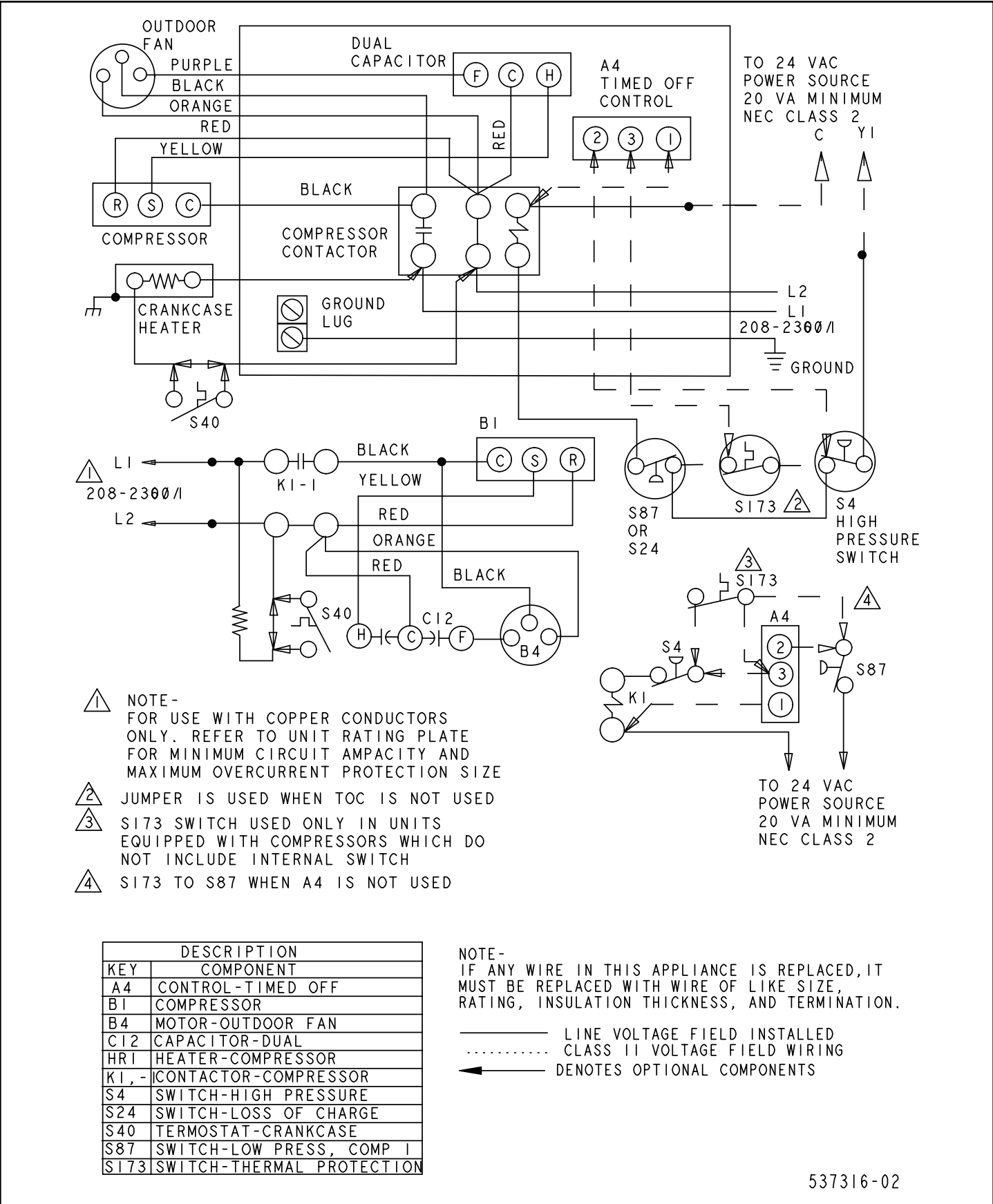

- ⚠ NOTE - FOR USE WITH COPPER CONDUCTORS ONLY. REFER TO UNIT RATING PLATE FOR MINIMUM CIRCUIT AMPACITY AND MAXIMUM OVERCURRENT PROTECTION SIZE
- ⚡ JUMPER IS USED WHEN TOC IS NOT USED
- ⚡ S173 SWITCH USED ONLY IN UNITS EQUIPPED WITH COMPRESSORS WHICH DO NOT INCLUDE INTERNAL SWITCH
- ⚡ S173 TO S87 WHEN A4 IS NOT USED

KEY	DESCRIPTION
A4	CONTROL-TIMED OFF
B1	COMPRESSOR
B4	MOTOR-OUTDOOR FAN
C12	CAPACITOR-DUAL
HRI	HEATER-COMPRESSOR
KI, -	CONTACTOR-COMPRESSOR
S4	SWITCH-HIGH PRESSURE
S24	SWITCH-LOSS OF CHARGE
S40	TERMOSTAT-CRANKCASE
S87	SWITCH-LOW PRESS, COMP 1
S173	SWITCH-THERMAL PROTECTION

NOTE - IF ANY WIRE IN THIS APPLIANCE IS REPLACED, IT MUST BE REPLACED WITH WIRE OF LIKE SIZE, RATING, INSULATION THICKNESS, AND TERMINATION.

— LINE VOLTAGE FIELD INSTALLED  
 ..... CLASS 11 VOLTAGE FIELD WIRING  
 ◀ DENOTES OPTIONAL COMPONENTS

537316-02

**Figure 13. A/C Single Phase Wiring Diagram**

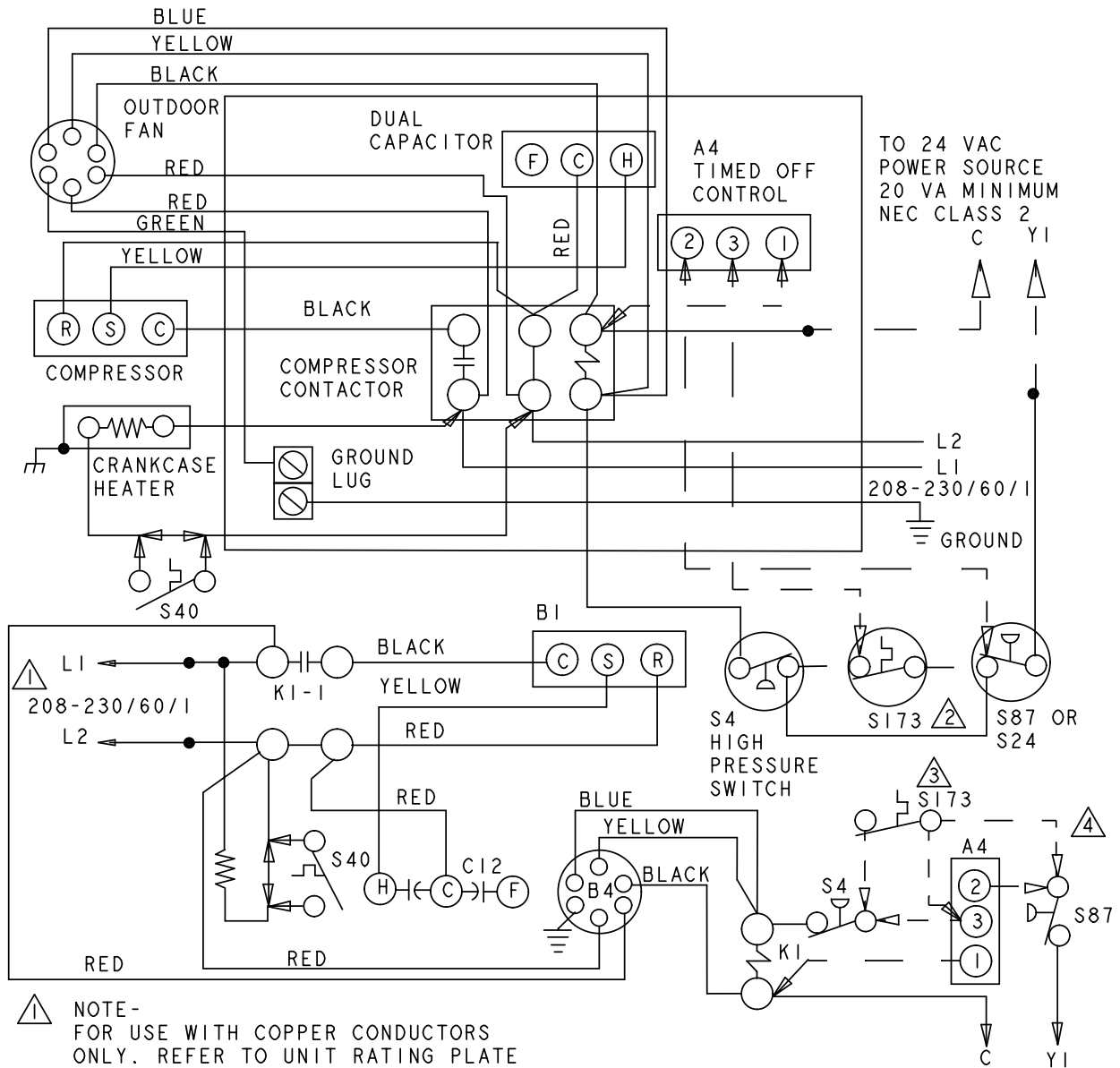

- NOTE -  
 FOR USE WITH COPPER CONDUCTORS ONLY. REFER TO UNIT RATING PLATE FOR MINIMUM CIRCUIT AMPACITY AND MAXIMUM OVERCURRENT PROTECTION SIZE
- JUMPER IS USED WHEN TOC IS NOT USED
- S173 SWITCH USED ONLY IN UNITS EQUIPPED WITH COMPRESSORS WHICH DO NOT INCLUDE INTERNAL SWITCH
- S173 TO S87 WHEN A4 IS NOT USED

TO 24 VAC  
 POWER SOURCE  
 20 VA MINIMUM  
 NEC CLASS 2

KEY	DESCRIPTION
A4	CONTROL-TIMED OFF
B1	COMPRESSOR
B4	MOTOR-OUTDOOR FAN
C12	CAPACITOR-DUAL
HRI	HEATER-COMPRESSOR
K1,-	CONTACTOR-COMPRESSOR
S4	SWITCH-HIGH PRESSURE
S24	SWITCH-LOSS OF CHARGE
S40	TERMOSTAT-CRANKCASE
S87	SWITCH-LOW PRESS, COMP I
S173	SWITCH-THERMAL PROTECTION

NOTE -  
 IF ANY WIRE IN THIS APPLIANCE IS REPLACED, IT MUST BE REPLACED WITH WIRE OF LIKE SIZE, RATING, INSULATION THICKNESS, AND TERMINATION.

— LINE VOLTAGE FIELD INSTALLED  
 ..... CLASS II VOLTAGE FIELD WIRING  
 ◀ — — DENOTES OPTIONAL COMPONENTS

537667-01

Figure 14. A/C Single Phase Wiring Diagram (59 model only)

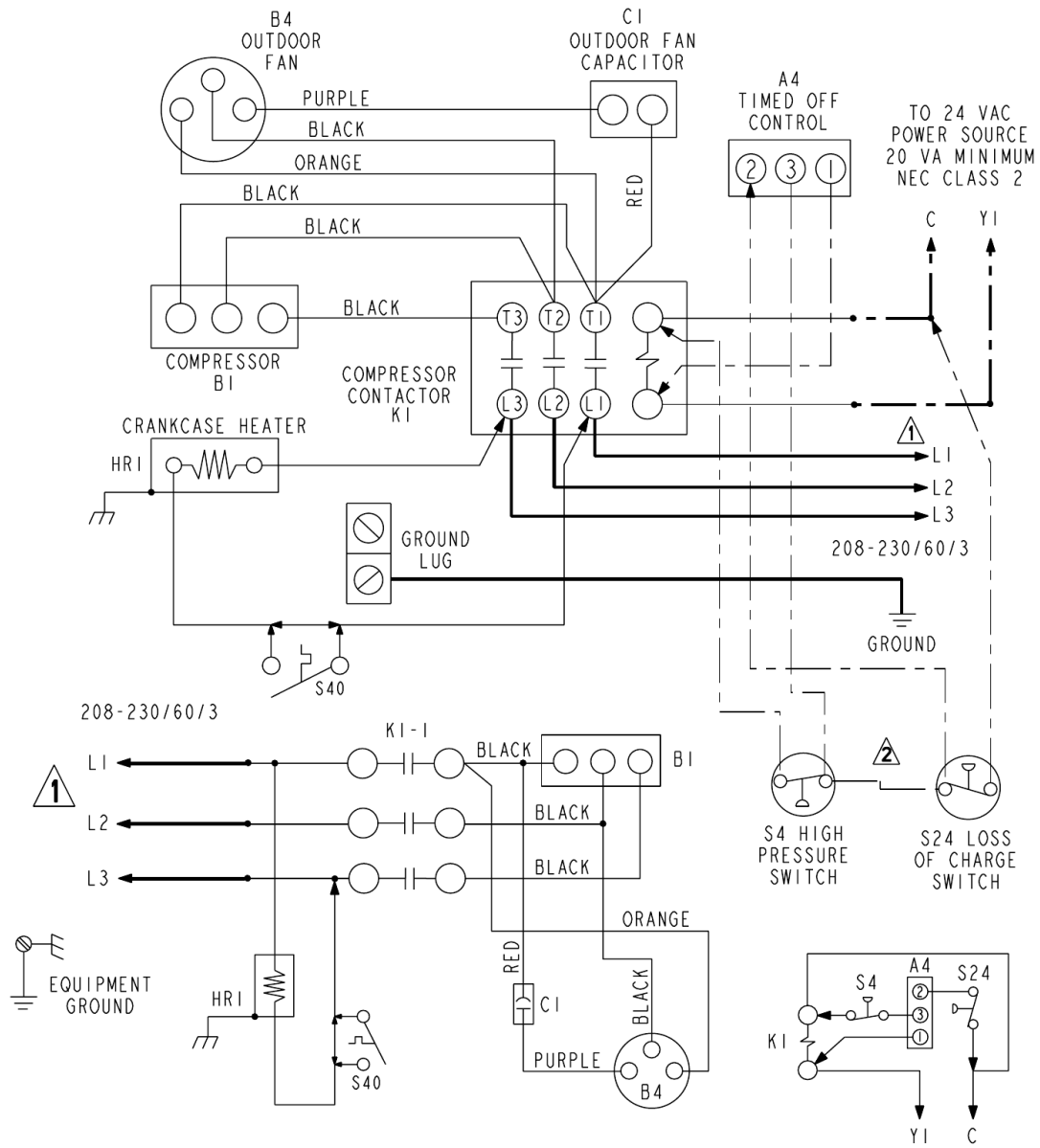

DESCRIPTION	
KEY	COMPONENT
A4	CONTROL - TIMED OFF
B1	COMPRESSOR
B4	MOTOR - OUTDOOR FAN
C1	CAPACITOR - OUTDOOR FAN
HR1	HEATER - COMPRESSOR
KI-1	CONTACTOR - COMPRESSOR
S4	SWITCH - HIGH PRESSURE
S24	SWITCH - LOSS OF CHARGE
S40	THERMOSTAT - CRANKCASE

**1** FOR USE WITH COPPER CONDUCTORS ONLY. REFER TO UNIT RATING PLATE FOR MINIMUM CIRCUIT AMPACITY AND MAXIMUM OVERCURRENT PROTECTION SIZE.

**2** JUMPER IS USED WHEN TOC IS NOT USED.

WARNING--  
ELECTRIC SHOCK HAZARD, CAN CAUSE INJURY OR DEATH. UNIT MUST BE GROUNDED IN ACCORDANCE WITH NATIONAL AND LOCAL CODES.

← DENOTES OPTIONAL COMPONENTS

— LINE VOLTAGE FIELD INSTALLED  
 - - - CLASS II VOLTAGE FIELD INSTALLED  
 - · - · 24 VOLT FACTORY INSTALLED

48436-001

Figure 15. 3 Phase (208-230 Volt)

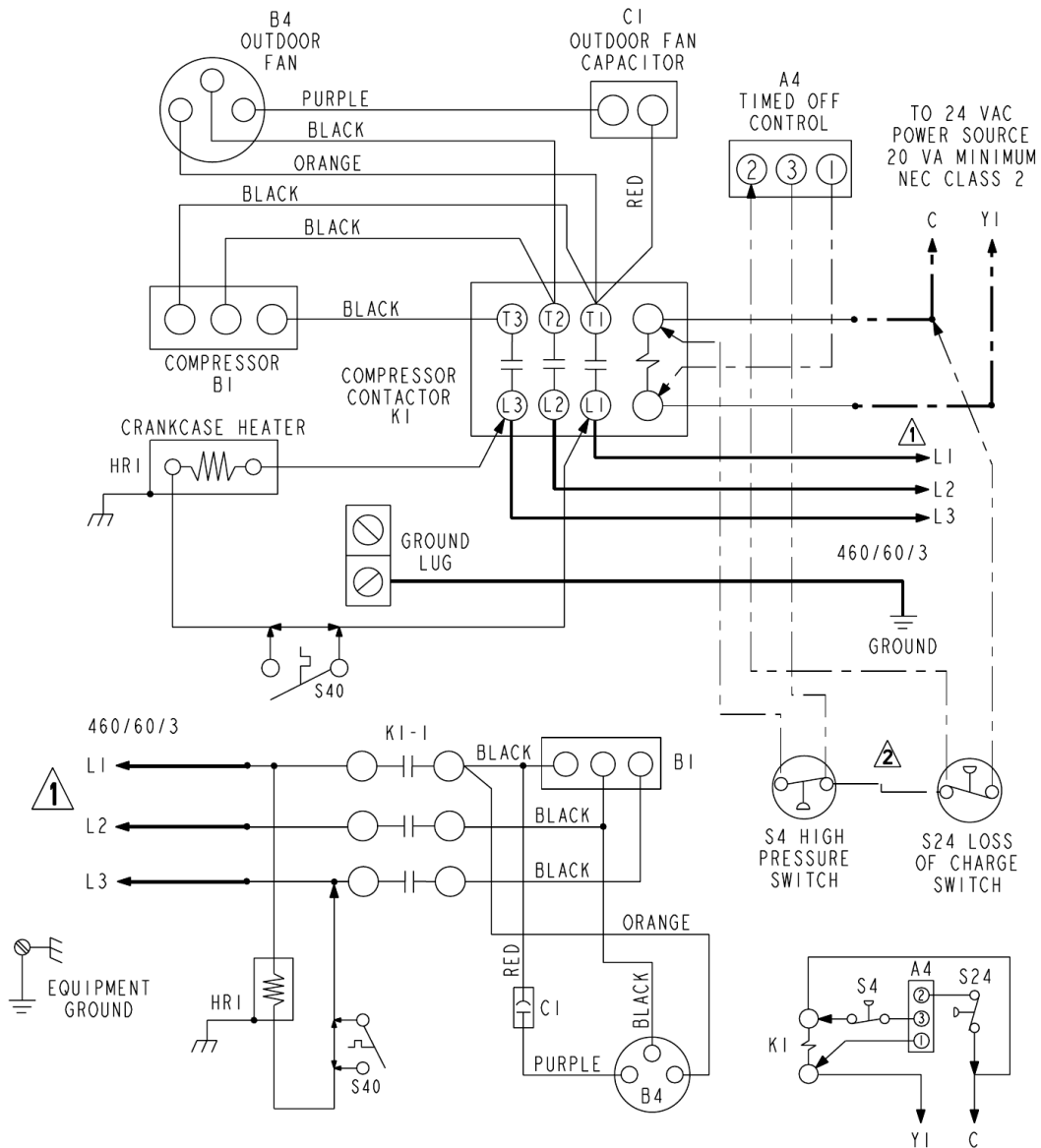

DESCRIPTION	
KEY	COMPONENT
A4	CONTROL - TIMED OFF
B1	COMPRESSOR
B4	MOTOR - OUTDOOR FAN
C1	CAPACITOR - OUTDOOR FAN
HRI	HEATER - COMPRESSOR
K1-1	CONTACTOR - COMPRESSOR
S4	SWITCH - HIGH PRESSURE
S24	SWITCH - LOSS OF CHARGE
S40	THERMOSTAT - CRANKCASE

**1** FOR USE WITH COPPER CONDUCTORS ONLY. REFER TO UNIT RATING PLATE FOR MINIMUM CIRCUIT AMPACITY AND MAXIMUM OVERCURRENT PROTECTION SIZE.

**2** JUMPER IS USED WHEN TOC IS NOT USED.

WARNING --  
ELECTRIC SHOCK HAZARD, CAN CAUSE INJURY OR DEATH. UNIT MUST BE GROUNDED IN ACCORDANCE WITH NATIONAL AND LOCAL CODES.

← DENOTES OPTIONAL COMPONENTS

— LINE VOLTAGE FIELD INSTALLED  
 - - - CLASS 11 VOLTAGE FIELD INSTALLED  
 - - - 24 VOLT FACTORY INSTALLED

TO 24 VAC POWER SOURCE  
 20 VA MINIMUM  
 NEC CLASS 2

537217-01

Figure 16. 3 Phase (460 Volt)

## Servicing Units Void of Charge

If the outdoor unit is void of refrigerant, clean the system using the procedure described below.

1. Leak check system using procedure outlined on Page 26.
2. Evacuate the system using procedure outlined on Page 26.
3. Use nitrogen to break the vacuum and install a new filter drier in the system.
4. Evacuate the system again using procedure outlined on Page 26.
5. Weigh in refrigerant. Refer to data plate and line set length for proper charge.

## System Refrigerant

This section outlines procedures for:

1. Connecting gauge set for testing and charging;
2. Checking and adjusting indoor airflow;
3. Adding or removing refrigerant.

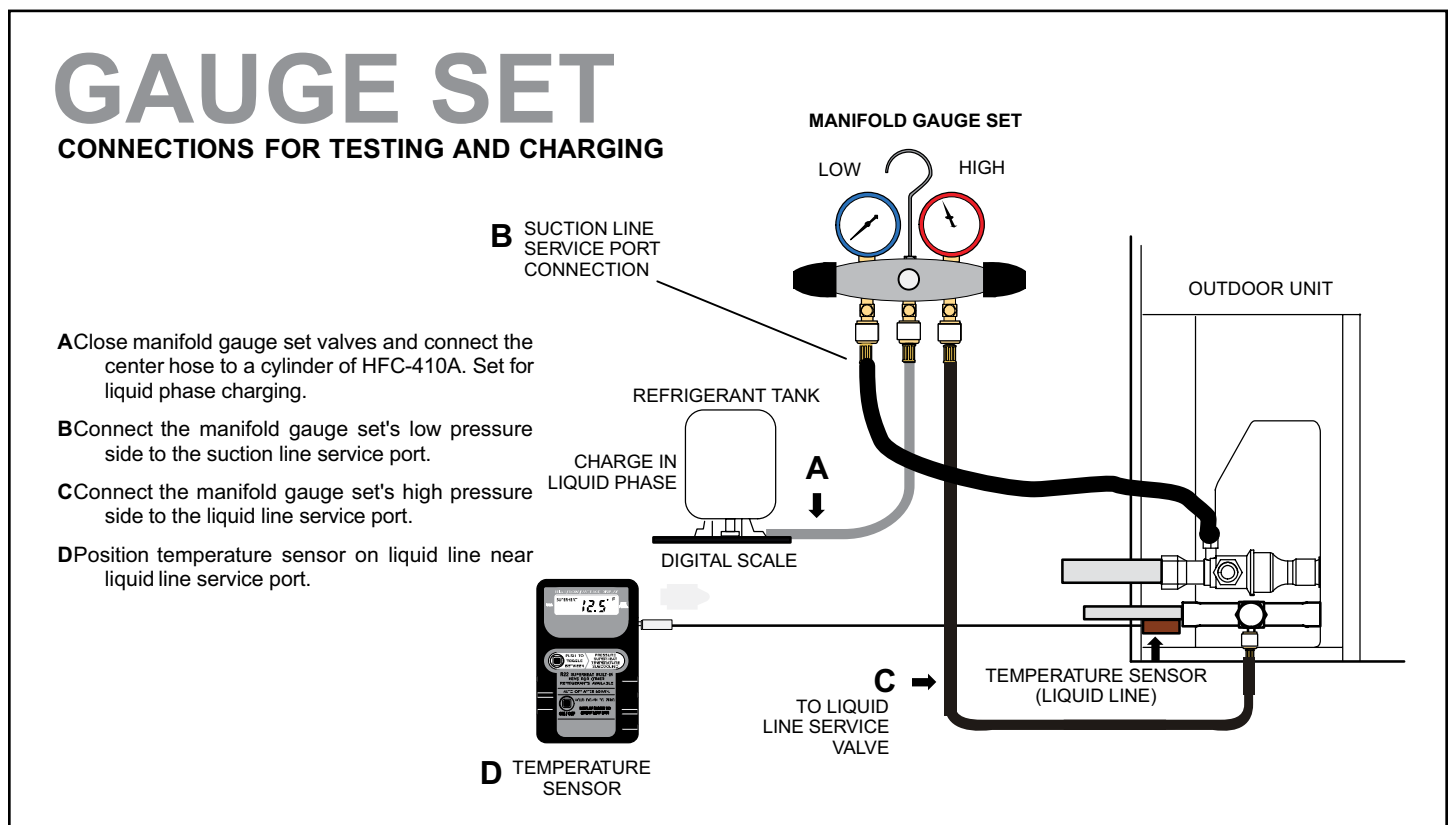

## Adding or Removing Refrigerant

This system uses HFC-410A refrigerant which operates at much higher pressures than HCFC-22. The pre-installed liquid line filter drier is approved for use with HFC-410A only. Do not replace it with components designed for use with HCFC-22. This unit is NOT approved for use with coils which use capillary tubes or fixed orifices as a refrigerant metering device. Check airflow using the Delta-T (DT) process shown below..

# AIRFLOW

### INDOOR COIL

**Temperature of air entering indoor coil °F**

**A**

Dry-bulb	DT															
	80	24	24	24	23	23	22	22	22	22	20	19	18	17	16	15
78	23	23	23	22	22	21	21	21	20	19	18	17	16	15	14	
76	22	22	22	21	21	20	19	19	18	17	16	15	14	13		
74	21	21	21	20	19	19	18	17	16	16	15	14	13	12		
72	20	20	19	18	17	17	16	15	15	14	13	12	11	10		
70	19	19	18	18	17	17	16	15	15	14	13	12	11	10		
Wet-bulb °F	57	58	59	60	61	62	63	64	65	66	67	68	69	70		

All temperatures are expressed in °F

Use the following procedure to adjust for optimal air flow across the indoor coil:

- Determine the desired DT** — Measure entering air temperature using dry bulb (A) and wet bulb (B). DT is the intersecting value of A and B in the table (see triangle).
- Find temperature drop across coil** — Measure the coil's dry bulb entering and leaving air temperatures (A and C). Temperature Drop Formula: ( $T_{Drop}$ ) = A minus C.
- Determine if fan needs adjustment** — If the difference between the measured  $T_{Drop}$  and the desired DT ( $T_{Drop}-DT$ ) is within  $\pm 3^\circ$ , no adjustment is needed. See example below:

Assume DT = 15 and A temp. = 72°, these C temperatures would necessitate stated actions:

C°	$T_{Drop}$	-	DT	=	°F	ACTION
53°	19	-	15	=	4	Increase the airflow
58°	14	-	15	=	-1	(within $\pm 3^\circ$ range) no change
62°	10	-	15	=	-5	Decrease the airflow

Changing air flow affects all temperatures; recheck temperatures to confirm that the temperature drop and DT are within  $\pm 3^\circ$ .

- Adjust the fan speed** — See indoor unit instructions to increase/decrease fan speed.

°F	°C	Psig	°F	°C	Psig
-40	-40.0	11.6	60	15.6	170.0
-35	-37.2	14.9	65	18.3	185.0
-30	-34.4	18.5	70	21.1	201.0
-25	-31.7	22.5	75	23.9	217.0
-20	-28.9	26.9	80	26.7	235.0
-15	-26.1	31.7	85	29.4	254.0
-10	-23.3	36.8	90	32.2	274.0
-5	-20.6	42.5	95	35.0	295.0
0	-17.8	48.6	100	37.8	317.0
5	-15.0	55.2	105	40.6	340.0
10	-12.2	62.3	110	43.3	365.0
15	-9.4	70.0	115	46.1	391.0
20	-6.7	78.3	120	48.9	418.0
25	-3.9	87.3	125	51.7	446.0
30	-1.1	96.8	130	54.4	476.0
35	1.7	107.0	135	57.2	507.0
40	4.4	118.0	140	60.0	539.0
45	7.2	130.0	145	62.8	573.0
50	10.0	142.0	150	65.6	608.0
55	12.8	155.0			

**Table 6. HFC-410A Temperature - Pressure (Psig)**



# Charge Labels

Capacity	-018	-024	-030	-036	-041	-042	-047	-048	-059	-060
<b>Table 1. Normal Operating Pressures<sup>1</sup></b>										
°F(°C) <sup>2</sup>	TXV System - Liquid Line ( ± 10 psig) / Suction Line ( ± 5 psig)									
65 (18)	230 / 137	230 / 133	227 / 135	230 / 136	219 / 142	224 / 136	216 / 133	221 / 130	213 / 125	224 / 128
75 (24)	264 / 139	262 / 138	259 / 139	267 / 140	256 / 144	262 / 140	250 / 139	257 / 136	247 / 132	257 / 133
85 (29)	308 / 142	303 / 142	301 / 141	311 / 142	299 / 147	305 / 143	293 / 142	300 / 141	288 / 136	301 / 136
95 (35)	361 / 144	351 / 144	349 / 143	358 / 145	346 / 149	353 / 145	339 / 144	346 / 145	337 / 139	349 / 139
105 (41)	414 / 146	402 / 146	401 / 146	409 / 146	396 / 151	405 / 148	390 / 147	399 / 148	387 / 142	402 / 142
115 (45)	474 / 148	461 / 148	461 / 149	470 / 150	452 / 154	462 / 150	448 / 150	454 / 150	443 / 144	459 / 145
°F(°C) <sup>2</sup>	RFC System - Liquid Line ( ± 10 psig) / Suction Line ( ± 5 psig )									
65 (18)	234 / 135	234 / 126	228 / 133	236 / 128	---	228 / 129	---	227 / 125	---	225 / 121
75 (24)	266 / 139	265 / 132	262 / 137	274 / 135	---	264 / 137	---	262 / 133	---	260 / 129
85 (29)	304 / 143	305 / 138	302 / 141	315 / 140	---	307 / 142	---	303 / 139	---	301 / 135
95 (35)	348 / 147	350 / 143	346 / 145	362 / 145	---	352 / 147	---	349 / 144	---	347 / 140
105 (41)	402 / 151	401 / 147	394 / 148	414 / 148	---	401 / 151	---	399 / 148	---	369 / 144
115 (46)	453 / 154	455 / 151	449 / 152	471 / 152	---	455 / 155	---	453 / 152	---	450 / 147
<b>Table 2. Approach (APP) Values<sup>3</sup> -TXV System - °F (°C) ± 1°F (0.5°C)</b>										
65 (18)	2 (1.1)	1 (0.5)	2 (1.1)	7 (3.9)	7 (3.9)	7 (3.9)	3 (1.7)	6 (3.3)	5 (2.8)	4 (2.2)
75 (24)	1 (0.5)	3 (1.7)	4 (2.2)	8 (4.4)	7 (3.9)	8 (4.4)	4 (2.2)	6 (3.3)	6 (3.3)	4 (2.2)
85 (29)	1 (0.5)	4 (2.2)	5 (2.8)	9 (5.0)	7 (3.9)	8 (4.4)	4 (2.2)	7 (3.9)	6 (3.3)	4 (2.2)
95 (35)	1 (0.5)	4 (2.2)	4 (2.2)	9 (5.0)	7 (3.9)	7 (3.9)	4 (2.2)	7 (3.9)	6 (3.3)	4 (2.2)
105 (41)	1 (0.5)	3 (1.7)	4 (2.2)	8 (4.4)	7 (3.9)	7 (3.9)	4 (2.2)	7 (3.9)	5 (2.8)	4 (2.2)
115 (45)	0 (0)	3 (1.7)	4 (2.2)	8 (4.4)	6 (3.3)	7 (3.9)	5 (2.8)	6 (3.3)	5 (2.8)	4 (2.2)
<b>Table 3. Subcooling (SC) Values<sup>4</sup> -TXV System - °F (°C) ± 1°F (0.5°C)</b>										
65 (18)	12 (6.7)	13 (7.2)	11 (6.1)	7 (3.9)	4 (2.2)	5 (2.8)	6 (3.3)	5 (2.8)	4 (2.2)	8 (4.4)
75 (24)	11 (6.1)	10 (5.6)	7 (3.9)	5 (2.8)	4 (2.2)	4 (2.2)	5 (2.8)	5 (2.8)	3 (1.7)	7 (3.9)
85 (29)	13 (7.2)	8 (4.4)	7 (3.9)	5 (2.8)	4 (2.2)	5 (2.8)	6 (3.3)	4 (2.2)	3 (1.7)	7 (3.9)
95 (35)	13 (7.2)	9 (5.0)	7 (3.9)	5 (2.8)	5 (2.8)	5 (2.8)	6 (3.3)	4 (2.2)	4 (2.2)	8 (4.4)
105 (41)	14 (7.8)	9 (5.0)	8 (4.4)	6 (3.3)	5 (2.8)	6 (3.3)	6 (3.3)	5 (2.8)	4 (2.2)	8 (4.4)
115 (46)	15 (8.3)	10 (5.6)	9 (5.0)	6 (3.3)	5 (2.8)	6 (3.3)	6 (3.3)	6 (3.3)	5 (2.8)	8 (4.4)
<p><sup>1</sup> Typical pressures; indoor evaporator match-up, indoor air quantity and evaporator load will cause the pressures to vary.      <sup>3</sup> Approach = Liquid Line Temperature minus Outdoor Ambient Temperature</p> <p><sup>2</sup> Temperature of air entering outside coil.      <sup>4</sup> Subcooling = Saturation Temperature minus Liquid Line Temperature</p>										

**AIRFLOW CHECK** - Both airflow and refrigerant charge must be monitored for proper system set-up. It may be necessary to alternately check and adjust the airflow and the refrigerant charge.

**NOTE:** Be sure that filters and indoor and outdoor coils are clean before testing. To determine temperature drop across indoor coil (Delta-T), measure the entering air dry bulb (DB) and wet bulb (WB) temperatures at the indoor coil. Find Delta-T in table 4. Measure coil's leaving air DB and subtract that value from entering air DB. The measured difference should be within ±3°F (±1.8°C) of table value; if too low, decrease the indoor fan speed (refer to indoor unit for information). If the Delta-T is too high, increase the indoor fan speed. Repeat charging procedure and Delta-T (air flow adjustment) procedure until both are correct.

**Example:** Assume entering air DB - 72, WB - 64, leaving DB - 53. Therefore, Delta-T should be 15 (per table); delta across coil is 72 - 53 or 19 (which is 4°F higher than table value). Action necessary: increase fan speed.

Dry bulb temperature of air entering indoor coil (°F)

**Table 4. Evaporator Coil Delta-T**

80	24	24	23	23	22	22	22	20	19	18	17	16	15
78	23	23	22	22	21	21	20	19	18	17	16	15	14
76	22	22	21	21	20	19	19	18	17	16	15	14	13
74	21	21	20	19	19	18	17	16	16	15	14	13	12
72	20	20	19	18	17	17	16	15	15	14	13	12	11
70	19	19	18	17	17	16	15	15	14	13	12	11	10
°F	57	58	59	60	61	62	63	64	65	66	67	68	69
	[ Wet bulb temperature of air entering indoor coil ]												

**Table 5. RFC Sizes**

Capacity	-018	-024	-030	-036	-041	-042	-047	-048	-059	-060
RFC Size	0.052	0.060	0.067	0.072	TXV	0.081	TXV	0.083	TXV	0.097

**Table 6. Superheat Value (RFC)\* ± 1°F (0.5°C)**

Outdoor Temp (°F)	65	70	75	80	85	90	95	100	105
<b>C</b>	21	21	21	19	18	16	13	9	1
<b>A</b>	25	25	24	23	22	21	19	16	13
<b>P</b>	20	20	19	17	15	13	9	7	4
<b>A</b>	26	25	24	22	20	18	15	12	10
<b>C</b>	25	24	22	20	17	15	12	7	6
<b>I</b>	27	26	24	22	19	16	12	8	3
<b>T</b>	28	26	24	21	18	14	10	6	4

\*Suction line saturation temperature minus suction line temperature. All measurements are at the service valves and are based on 80db / 67wb indoor temperature.

580864-01

**Figure 17. 4SCU16LE/4SCU14LB-50**

## 14 SEER AIR CONDITIONING CHARGING PROCEDURE

1. CHARGE THE SYSTEM BY WEIGHT, IF OUTDOOR TEMPERATURE IS BELOW 65°F:

OUTDOOR UNITS ARE FACTORY CHARGED WITH R410A FOR 15 FT. OF LINE SET. ADD OR REMOVE 0.6 OZ. FOR EVERY FOOT OF LINE SET DIFFERENT THAN 15 FT. FINAL CHARGE ADJUSTMENT MUST BE MADE PER ITEM (2) BELOW, ONCE THE OUTDOOR TEMPERATURE RISE ABOVE 65 °F.

2. IF OUTDOOR TEMPERATURE IS ABOVE 65°F, ADJUST CHARGE AS FOLLOWS:

- A. CHECK FOR PROPER AIR FLOW AND RUN THE SYSTEM FOR 20 MINUTES FOR STABILIZATION
- B. USE SUPERHEAT FOR ORIFICE COILS (SEE TABLE BELOW)
- C. USE SUBCOOLING FOR TXV COILS (SEE TABLE BELOW), PROVIDED THAT SUPERHEAT IS WITHIN 8-16 °F AT OUTDOOR UNIT AND THE REFERENCED PRESSURES BELOW ARE WITHIN ± 3 PSI FOR LOW SIDE AND ± 10 PSI FOR HIGH SIDE
- D. CONTACT TECHNICAL SERVICE, IF MEASURED VALUES ARE OUTSIDE THE RANGE OF THE LISTED DATA

MODELS	18	24	30	36	41	42	47	48	59	60
<b>TABLE 1 - SUBCOOLING METHOD ( TXV SYSTEM ) ± 1 °F</b>										
<b>OUTDOOR TEMP (°F)</b>	<i>LIQUID LINE SATURATION TEMPERATURE MINUS LIQUID LINE TEMPERATURE</i>									
65	8	8	7	6	7	8	6	8	7	5
75	8	8	7	6	7	8	6	8	7	5
85	8	8	7	6	7	8	7	8	7	5
95	8	8	7	8	7	8	8	8	7	5
105	10	10	9	8	7	10	8	8	8	5
115	11	11	9	8	8	10	8	9	8	6
<b>TABLE 2 - APPROACH METHOD ( TXV SYSTEM ) ± 1 °F - FOR REFERENCE ONLY</b>										
<i>LIQUID LINE TEMPERATURE MINUS OUTDOOR AMBIENT TEMPERATURE</i>										
TEMP (°F)	6	5	6	7	4	5	8	5	9	5
<b>TABLE 3 - OPERATING PRESSURES ( FOR REFERENCE )</b>										
<b>OUTDOOR TEMP (°F)</b>	<b>HIGH / LOW PRESSURES (PSI)</b>									
65	240/130	245/130	230/130	240/130	233/142	230/135	233/139	210/125	210/126	200/125
75	270/135	280/135	270/135	275/135	256/143	270/140	272/141	250/135	250/131	240/130
85	300/140	320/140	310/140	310/140	299/145	310/145	315/142	300/140	294/136	290/135
95	350/145	360/145	350/145	370/145	343/146	355/150	361/144	365/142	354/143	340/140
105	470/150	410/150	400/150	415/150	389/148	410/150	413/145	400/144	390/148	390/145
115	530/155	470/150	460/150	470/150	452/151	460/155	465/148	460/145	440/150	440/149

<b>TABLE 4 - SUPERHEAT METHOD ( ORIFICE SYSTEM ) ± 1 °F</b>										
<i>SUCTION LINE SATURATION TEMPERATURE MINUS SUCTION LINE TEMPERATURE</i>										
<b>OUTDOOR TEMP (°F)</b>	65	70	75	80	85	90	95	100	105	
<b>SUPERHEAT (°F)</b>	35	30	25	22	18	12	8	5	5	

ALL MEASUREMENTS ARE AT THE SERVICE VALVES AND ARE BASED ON 80db/67wb INDOOR TEMPERATURE.

ORIFICE	18	24	30	36	41	42	47	48	59	60
	0.053	0.057	.065	0.071	NA	NA	NA	NA	NA	NA

TXV	H4TXV01	H4TXV02	H4TXV03
-----	---------	---------	---------

580517-06

**Figure 18. 4SCU14LE/LB\*-4 thru 7**

## Start-Up and Performance Checklist

Job Name \_\_\_\_\_ Job no. \_\_\_\_\_ Date \_\_\_\_\_

Job Location \_\_\_\_\_ City \_\_\_\_\_ State \_\_\_\_\_

Installer \_\_\_\_\_ City \_\_\_\_\_ State \_\_\_\_\_

Unit Model No. \_\_\_\_\_ Serial No. \_\_\_\_\_ Service Technician \_\_\_\_\_

Nameplate Voltage \_\_\_\_\_

Rated Load Ampacity \_\_\_\_\_ Compressor \_\_\_\_\_ Outdoor Fan \_\_\_\_\_

Maximum Fuse or Circuit Breaker \_\_\_\_\_

Electrical Connections Tight?  Indoor Filter Clean?  Supply Voltage (Unit Off) \_\_\_\_\_

Indoor Blower RPM \_\_\_\_\_ S.P. Drop Over Indoor (Dry) \_\_\_\_\_ Outdoor Coil Entering Air Temp. \_\_\_\_\_

Discharge Pressure \_\_\_\_\_ Vapor Pressure \_\_\_\_\_ Refrigerant Charge Checked?

Refrigerant Lines: Leak Checked?  Properly Insulated?  Outdoor Fan Checked?

Services Valve: Fully Opened?  Caps Tight?  Thermostat

Voltage with Compressor Operating \_\_\_\_\_ Calibrated?  Properly Set?  Level?