

PRAC14

PRODUCT SPECIFICATIONS

14 SEER ELECTRIC/ELECTRIC PACKAGED UNIT

FORM NO. PRAC14-100 (05/2019)

REFRIGERANT SYSTEM

- Environmentally friendly R410A refrigerant
- Copper tubing with enhanced fin coils
- Internal service gauge ports

CABINET CONSTRUCTION

- Rounded corners for safety and an attractive, clean appearance
- One piece base design for strength and stability
- Drain ports for condensate management and coil runoff
- Low profile, with compact footprint
- Insulation to minimize heat loss plus reduce sound
- Textured pre-painted steel cabinet finish
- Superior service access to components
- One piece “no leak” top design



BLOWER

- Insulated compartment to reduce sound
- Efficient constant torque motor for wide airflow range
- Slide out blower housing for easy service

INSTALLATION

- Horizontal or down discharge capable
- Utility connections on “right side”
- Tabbed duct flanges for simple duct connections

ACCESSORIES

- Roofcurbs
- Lifting brackets
- Internal filter kits
- Electric strip heat with optional single point power entry

WARRANTY

10 year limited parts and compressor warranty. See limited warranty document for details.



MODEL NUMBER GUIDE

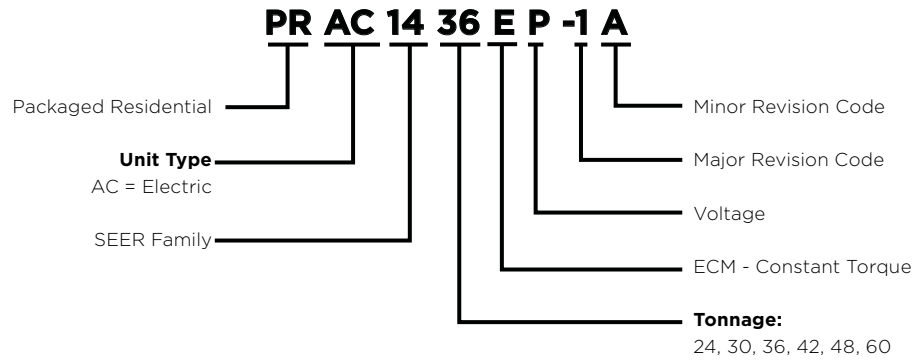

ELECTRICAL AND PHYSICAL DATA

Model	Voltage	Phase	Hz	Min Volts @ 60 hz	MCA	Max Fuse/HACR Breaker	Compressor		Condenser Motor		Blower Motor		Refrig. Charge (oz.)	Weight (lbs.)		
							RLA	LRA	RLA	HP	RLA	HP				
PRAC1424	208-230	1	60	197	14.4	20	8.6	43.5	1.0	1/6	2.8	1/3	72	290		
PRAC1430					18.2	25	10.6	47			4.1	1/2			80	301
PRAC1436					22.7	35	15.7	72.2			4.1	1/2			87	314
PRAC1442					1.7	1/4	27.5	40	15.9	112.3	6	3/4	108	383		
PRAC1448							28.7	45	16.9	94	6	3/4	115	389		
PRAC1460							38.9	60	26.4	152.5	7.6	1	125	423		

PERFORMANCE

Model	Cooling					Sound dBA
	Rated AHRI Capacity Btuh	SEER	EER	Rated Sensible Capacity Btuh	CFM	
PRAC1424	22,600	14.0	11.0	17,400	800	77
PRAC1430	28,400			21,900	1000	79
PRAC1436	34,000			26,100	1200	78
PRAC1442	40,000			30,800	1400	
PRAC1448	45,500			35,000	1600	77
PRAC1460	57,000			41,600	1800	78

*Certified in accordance with Unitary Air Conditioner Certification Program, which is based on AHRI Standard 210/240

BLOWER PERFORMANCE

MODEL	BLOWER TAP	CFM @ ext. Static Pressure in in. wc without filter, dry coil									
		0.1	0.2	0.3	0.4	0.5	0.6	0.7	0.8	0.9	1.0
PRAC1424	TAP 1	610	560	525	485	430	0	0	0	0	0
	TAP 2	820	795	760	720	690	650	615	575	540	470
	TAP 3	950	920	880	850	820	800	760	720	680	625
PRAC1430	TAP 1	850	820	780	745	710	680	630	590	550	515
	TAP 2	1040	1000	970	935	900	875	845	815	770	735
	TAP 3	1175	1145	1115	1080	1050	1015	990	945	900	860
PRAC1436	TAP 1	850	800	750	700	645	600	550	480	435	0
	TAP 2	1245	1210	1175	1140	1100	1065	1025	975	920	845
	TAP 3	1400	1370	1335	1300	1265	1220	1180	1150	1060	875
PRAC1442	TAP 1	800	720	640	550	475	390	310	0	0	0
	TAP 2	1470	1410	1360	1300	1260	1210	1155	1095	1000	940
	TAP 3	1700	1650	1610	1575	1540	1480	1430	1390	1340	1210
PRAC1448	TAP 1	1145	1075	1000	930	850	790	740	670	570	490
	TAP 2	1675	1630	1600	1540	1490	1440	1390	1300	1230	1125
	TAP 3	1800	1770	1715	1690	1640	1610	1565	1500	1460	1380
PRAC1460	TAP 1	1400	1320	1260	1200	1120	1060	980	900	N/A	N/A
	TAP 2	1920	1870	1820	1770	1720	1670	1450	1360	N/A	N/A
	TAP 3	2235	2195	2165	2130	2090	2060	2025	1985	1960	1940

COOLING PERFORMANCE - EXTENDED RATINGS

Outdoor Model	Indoor Temp DB/ WB °F	Outdoor Temperature - DB °F														
		65°			82° / 67°			95° / 75°			105° / 85°			115° / 95°		
		Btuh	S/T	kW	Btuh	S/T	kW	Btuh	S/T	kW	Btuh	S/T	kW	Btuh	S/T	kW
PRAC1424	85 / 72	30,600	0.65	1.33	27,700	0.68	1.65	24,700	0.70	1.88	23,100	0.72	2.06	22,500	0.75	2.26
	80 / 67	27,900	0.71	1.35	25,500	0.74	1.65	22,600	0.77	1.88	21,200	0.79	2.06	20,700	0.82	2.25
	75 / 63	26,000	0.74	1.36	23,800	0.77	1.65	21,000	0.79	1.87	20,700	0.82	2.05	19,300	0.84	2.23
	75 / 57	23,800	1	1.39	22,100	1	1.64	20,700	1	1.87	19,600	1	2.04	18,500	1.00	2.22
PRAC1430	85 / 72	38,200	0.68	1.83	34,700	0.71	2.16	32,000	0.74	2.42	30,500	0.74	2.6	29,000	0.78	2.86
	80 / 67	35,200	0.75	1.76	32,300	0.78	2.11	28,400	0.75	2.34	28,100	0.84	2.57	25,100	0.8	2.74
	75 / 63	33,000	0.77	1.71	30,400	0.8	2.06	27,700	0.8	2.31	25,900	0.82	2.51	24,100	0.84	2.72
	75 / 57	29,900	1	1.66	28,300	1	2.01	26,600	1	2.29	25,200	1	2.49	23,700	1	2.7
PRAC1436	85 / 72	45,800	0.68	2.09	41,700	0.72	2.49	37,600	0.73	2.82	35,400	0.74	3.1	32,400	0.75	3.39
	80 / 67	40,800	0.75	2.1	38,500	0.75	2.51	34,400	0.79	2.81	33,200	0.84	3.09	30,500	0.85	3.38
	75 / 63	38,100	0.76	2.11	36,000	0.77	2.51	32,300	0.81	2.80	30,500	0.84	3.08	28,400	0.87	3.37
	75 / 57	35,200	1	2.14	33,600	1	2.5	30,700	1	2.80	29,200	1	3.07	27,400	1	3.36
PRAC1442	85 / 72	54,500	0.67	2.51	48,900	0.71	2.9	45,700	0.73	3.28	44,200	0.74	3.64	42,800	0.75	4.08
	80 / 67	50,100	0.74	2.52	45,100	0.78	2.91	40,000	0.77	3.28	38,400	0.79	3.64	35,700	0.8	4.05
	75 / 63	46,800	0.76	2.52	42,700	0.8	2.91	38,800	0.81	3.29	36,300	0.82	3.65	33,500	0.83	4.06
	75 / 57	42,500	1	2.53	39,700	1	2.93	37,100	1	3.3	35,100	1	3.66	33,100	1	4.07
PRAC1448	85 / 72	59,400	0.69	2.78	53,900	0.72	3.29	49,700	0.72	3.6	47,100	0.75	4.09	43,600	0.75	4.48
	80 / 67	54,600	0.75	2.8	49,900	0.77	3.3	46,000	0.80	3.71	42,900	0.8	4.07	40,000	0.81	4.47
	75 / 63	50,700	0.76	2.82	46,700	0.79	3.3	43,300	0.82	3.7	40,400	0.82	4.06	38,100	0.86	4.47
	75 / 57	47,200	1	2.83	43,800	1	3.29	41,000	1	3.7	39,000	1	4.06	36,900	1	4.47
PRAC1460	85 / 72	70,300	0.63	3.5	66,100	0.64	4.19	62,800	0.65	4.72	59,200	0.7	5.27	55,500	0.76	5.82
	80 / 67	65,700	0.69	3.47	61,000	0.71	4.08	57,400	0.73	4.69	54,300	0.78	5.24	51,200	0.83	5.78
	75 / 63	61,400	0.72	3.45	56,300	0.74	4.12	52,300	0.76	4.63	50,200	0.8	5.19	48,000	0.85	5.75
	75 / 57	54,500	1	3.42	50,100	1	4.09	50,100	1	4.09	46,700	1	5.17	45,900	1	5.73

HEAT STRIP ELECTRICAL

Model Number	Heater Model	Unit Supply Voltage Single Phase	Heater kW	Min. Circuit Ampacity 1	Max. Fuse / HACR Brkr. 1	Min. Circuit Ampacity 2	Max. Fuse / HACR Brkr. 2	Min. Circuit Ampacity Single Point	Max. Fuse / HACR Brkr. Single Point
PRAC1424EP	PHK05BP-1	240	5	29.5	30	-	-	43.4	45
		208	3.8	26.1	25	-	-	40	45
	PHK07BP-1	240	7.5	42.6	45	-	-	56.5	60
		208	5.6	37.4	40	-	-	51.3	60
	PHK10BP-1	240	10	55.6	55	-	-	69.5	70
		208	7.5	48.6	50	-	-	62.5	70
PRAC1430EP	PHK05BP-1	240	5	31.2	35	-	-	47.9	50
		208	3.8	27.7	25	-	-	44.5	50
	PHK07BP-1	240	7.5	44.2	45	-	-	61	70
		208	5.6	39	40	-	-	55.8	60
	PHK10BP-1	240	10	57.2	55	-	-	74	80
		208	7.5	50.3	55	-	-	67	70
	PHK15CP-1	240	15	57.2	55	26	30	100	110
		208	11.3	50.3	55	22.6	25	89.6	90
PRAC1436EP	PHK05BP-1	240	5	31.2	30	-	-	49.5	50
		208	3.8	27.7	25	-	-	46	50
	PHK07BP-1	240	7.5	44.2	45	-	-	62.5	70
		208	5.6	39	40	-	-	57.3	60
	PHK10BP-1	240	10	57.2	55	-	-	75.5	80
		208	7.5	50.3	55	-	-	68.6	70
	PHK15CP-1	240	15	57.2	55	26	30	101.5	110
		208	11.3	50.3	50	22.6	25	91.1	100
PRAC1442EP	PHK05BP-1	240	5	33.5	35	-	-	53.8	60
		208	3.8	30.1	35	-	-	50.3	60
	PHK07BP-1	240	7.5	46.6	50	-	-	66.8	70
		208	5.6	41.4	45	-	-	61.6	70
	PHK10BP-1	240	10	59.6	55	-	-	79.9	80
		208	7.5	52.6	55	-	-	72.9	80
	PHK15CP-1	240	15	59.6	55	26	30	105.9	110
		208	11.3	52.6	55	22.6	25	95.5	100
PHK20CP-1	240	20	59.6	55	52.1	60	131.9	150	
	208	15	52.6	60	45.1	50	118	125	
PRAC1448EP	PHK05BP-1	240	5	33.5	35	-	-	54.8	60
		208	3.8	30.1	35	-	-	51.3	60
	PHK07BP-1	240	7.5	46.6	50	-	-	67.8	70
		208	5.6	41.4	45	-	-	62.6	70
	PHK10BP-1	240	10	59.6	60	-	-	80.8	90
		208	7.5	52.6	55	-	-	73.9	80
	PHK15CP-1	240	15	59.6	60	26	30	106.9	110
		208	11.3	52.6	55	22.6	25	96.4	100
PHK20CP-1	240	20	59.6	55	52.1	60	132.9	150	
	208	15	52.6	60	45.1	50	119	125	

MODEL NO.	HEATER MODEL	Unit Supply Voltage Single Phase	Heater kW	Min. Circuit Ampacity 1	Max. Fuse / HACR Brkr. 1	Min. Circuit Ampacity 2	Max. Fuse / HACR Brkr. 2	Min. Circuit Ampacity Single Point	Max. Fuse / HACR Brkr. Single Point
PRAC1460EP	PHK05BP-1	240	5	35.5	40	-	-	64.9	70
		208	3.8	32.1	35	-	-	61.5	65
	PHK07BP-1	240	7.5	48.6	50	-	-	78.8	90
		208	5.6	43.4	45	-	-	73.6	80
	PHK10BP-1	240	10	35.5	40	26	30	91.8	100
		208	7.5	54.6	60	-	-	84.8	90
	PHK15CP-1	240	15	52.1	55	35.5	40	117.8	125
		208	11.3	54.6	55	22.6	25	107.4	110
	PHK20CP-1	240	20	61.6	60	52.1	60	143.9	150
		208	15	54.6	60	45.1	50	130	150

ACCESSORIES

Description	Where Used	Kit Number
Compressor Crankcase Heater	36, 42, 48, 60	11X27
Compressor Hard Start Kit	36, 60	10J42
Compressor Hard Start Kit	42, 48	88M91
Compressor Timed-Off Control	All	47J27
Down Flow Conversion - ACONVR836	24, 30, 36	1.851401
Down Flow Conversion - ACONVR837	42, 48, 60	1.851402
Drain pan overflow switch	All	11U75
Electric Heater 5KW - PHK05BP	All	10W47
Electric Heater 7.5KW - PHK07BP	All	10W48
Electric Heater 10KW - PHK10BP	All	10W49
Electric Heater 15KW - PHK15CP	30, 36, 42, 48, 60	10W50
Electric Heater 20KW - PHK20CP	42, 48, 60	10W51
Filter Rack Kit	24, 30, 36	11U73
Filter Rack Kit	42, 48, 60	11U74
Lifting Brackets	All	11U76
Sideflow Rect. to 14" Rounds Duct Adapter (Qty 25 sets)	24, 30, 36	R104617-01
	42, 48, 60	R104618-01
8" Height Full Perimeter Curb	24, 30, 36	14W71
8" Height Full Perimeter Curb	42, 48, 60	14W72
14" Height Full Perimeter Curb	24, 30, 36	14V68
14" Height Full Perimeter Curb	42, 48, 60	14V69

Single Point Power		
5 KW ASPWR813-1	All	13W88
7.5 KW ASPWR814-1	All	13W89
10 KW ASPWR815-1	All	13W90
15-20 KW ASPWR816-1	30,36,42,48,60	13W91

DIMENSIONS (IN.)

Model	A		B		C		D		E		F		G		H	
	in.	mm	in.	mm	in.	mm	in.	mm	in.	mm	in.	mm	in.	mm	in.	mm
PRAC1424	36-7/8	937	46-3/4	1187	13-3/8	340	5-7/8	149	16-3/4	425	14	356	30-1/8	762	25-1/2	648
PRAC1430																
PRAC1436																
PRAC1442	40-7/8	1038	55-1/4	1403	18-1/8	467	4-5/8	117	19-3/4	502	19-1/2	495	34-1/8	864	29-1/2	749
PRAC1448																
PRAC1460																

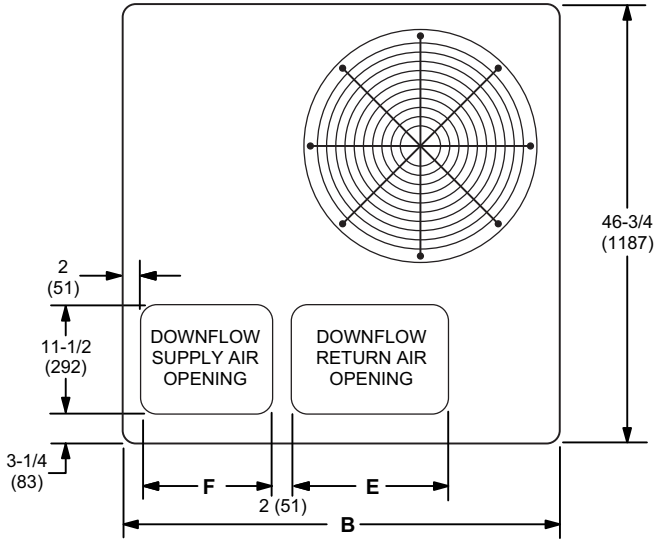

TOP VIEW

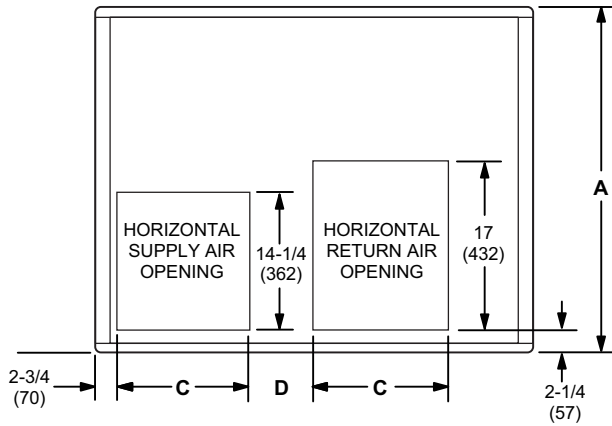

BACK VIEW

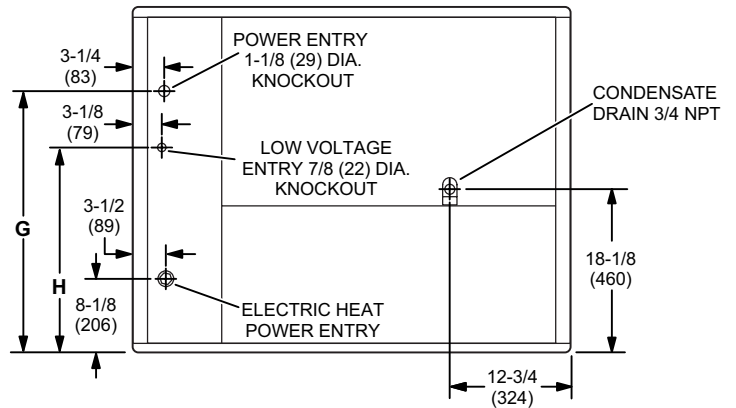

RIGHT SIDE VIEW

ROOF CURB DIMENSIONS

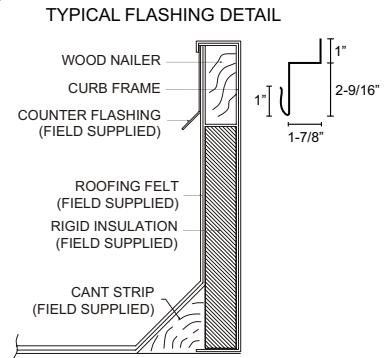
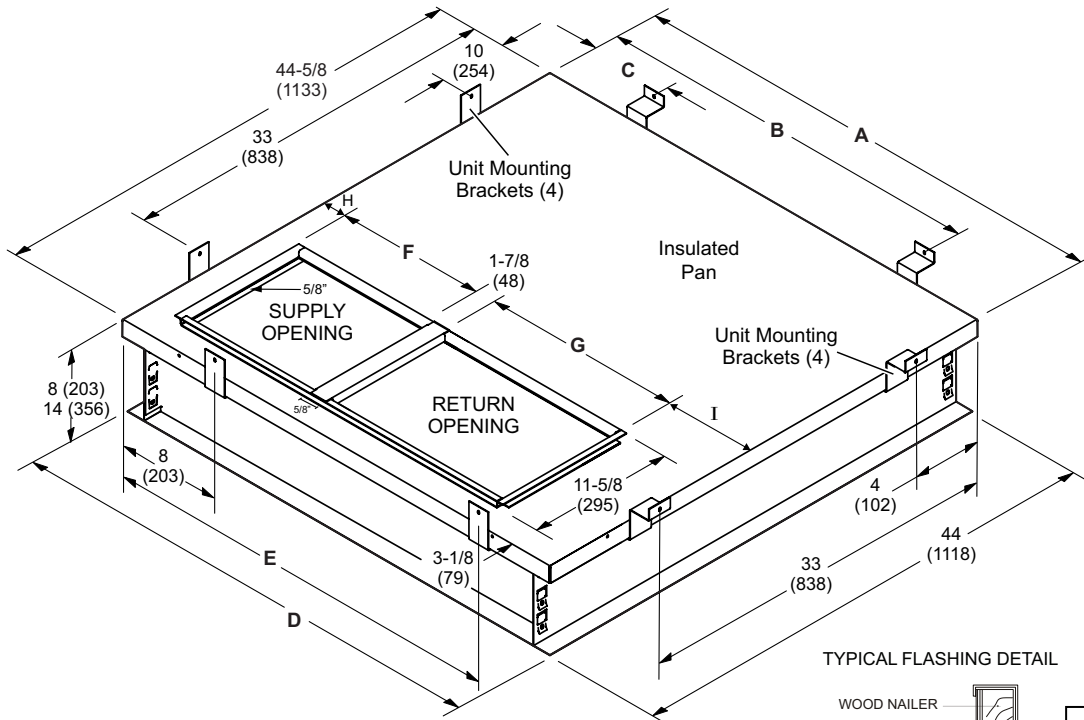

Usage	A		B		C		D		E	
	in.	mm	in.	mm	in.	mm	in.	mm	in.	mm
24, 36	44-5/8	1133	43	1092	18	457	44	1118	37	940
48, 60	53-1/8	1349	51	1295	24	610	52-1/2	1334	41	1041
Usage	F		G		H		I			
	in.	mm	in.	mm	in.	mm	in.	mm		
24, 36	14	356	16-3/4	425	2	51	9-3/4	248		
48, 60	19-1/2	495	19-3/4	502	2	51	10	254		



1-800-448-5872

All specifications and illustrations subject to change without notice and without incurring obligations.