

# INSTALLATION INSTRUCTIONS

## ⚠ WARNING

Improper installation, adjustment, alteration, service or maintenance can cause property damage, personal injury or loss of life. Installation and service must be performed by a licensed professional HVAC installer or equivalent or service agency.

**ZHA092** (7.5- Ton)

**ZHA102** (8.5 -Ton)

**ZHA120** (10 -Ton)

HEAT PUMP PACKAGED UNITS

507257-01

7/2014

## Table Of Contents

Dimensions .....	Page 2	Electrical Connections .....	Page 6
Shipping and Packing List .....	Page 3	Unit Power-Up .....	Page 6
General .....	Page 3	Blower Operation and Adjustments .....	Page 7
Safety .....	Page 3	Heating Start-Up .....	Page 13
Unit Support .....	Page 4	Cooling Start-Up .....	Page 13
Duct Connection .....	Page 4	Electric Heat Start-Up .....	Page 17
Rigging Unit For Lifting .....	Page 5	Defrost Control Board .....	Page 18
Condensate Drains .....	Page 5	Service .....	Page 19

**RETAIN THESE INSTRUCTIONS FOR FUTURE REFERENCE**

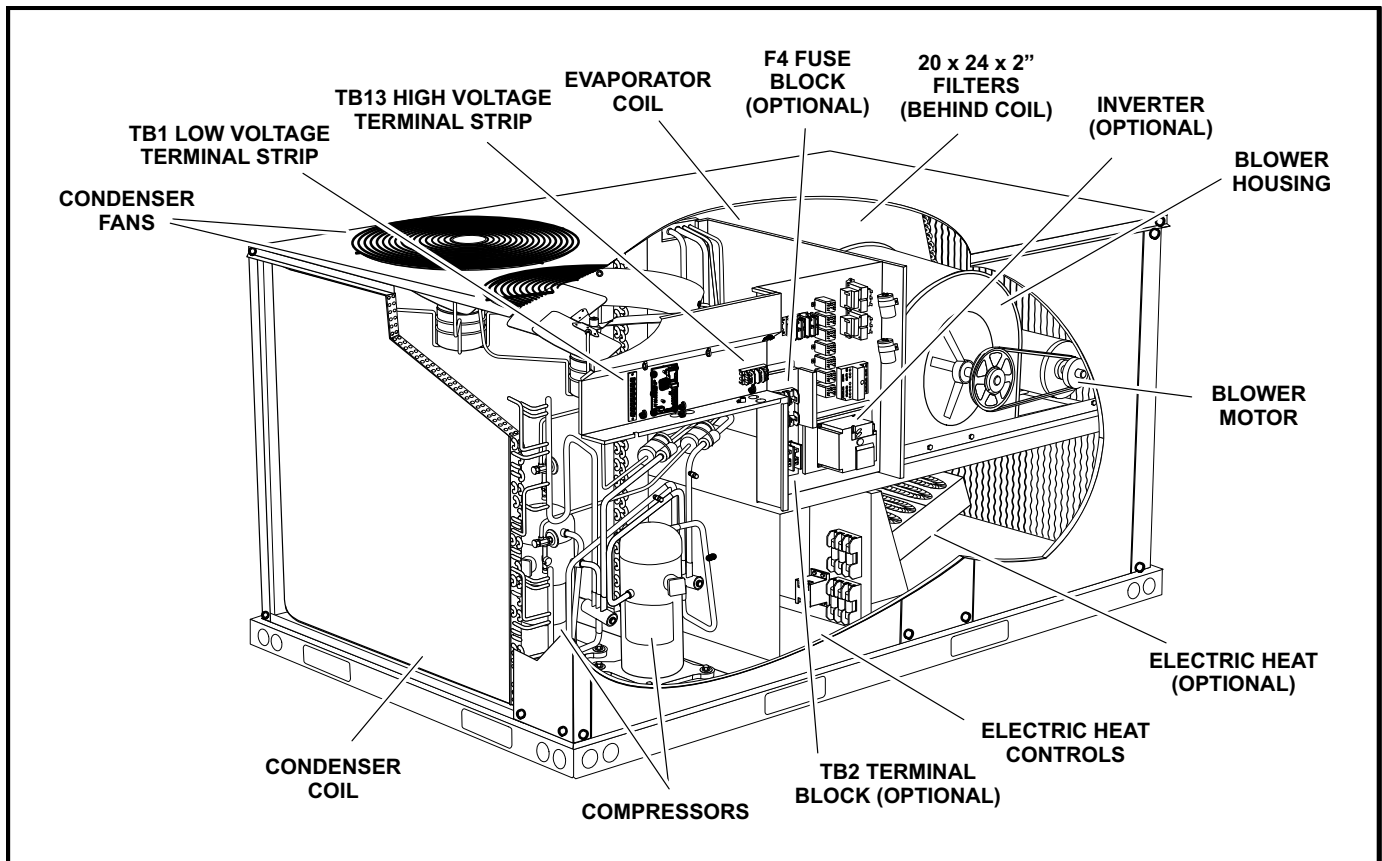

# ZH 092, 102 & 120 DIMENSIONS

## BOTTOM POWER ENTRY

Holes required for Optional Bottom Power Entry Kit

	Threaded Conduit Fittings (Provided in Kit)	Wire Use	Hole Diameter Required in Unit Base (Max.)
<b>A</b>	1/2	ACC.	7/8 (23)
<b>B</b>	1/2	24V	7/8 (23)
<b>C</b>	1-1/4	POWER	1-3/4 (44)

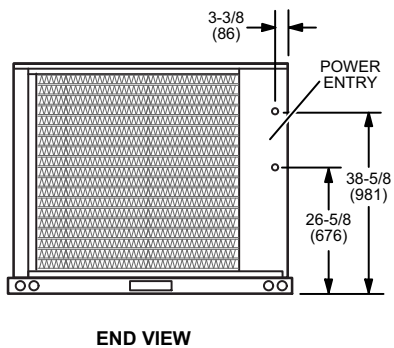
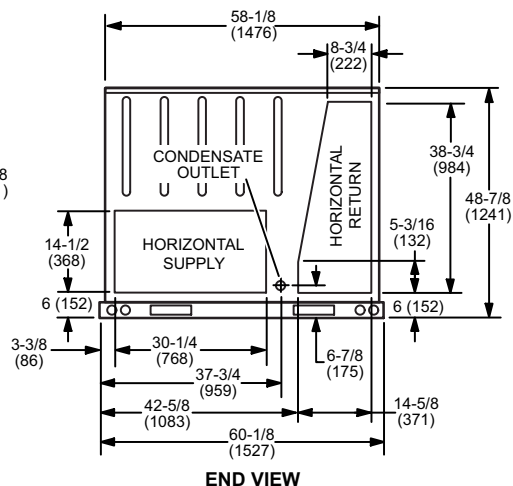
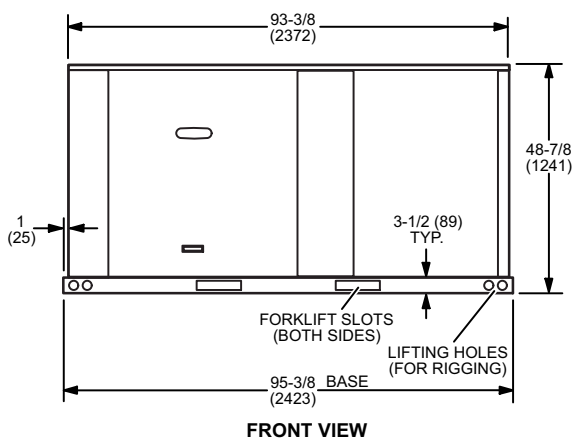
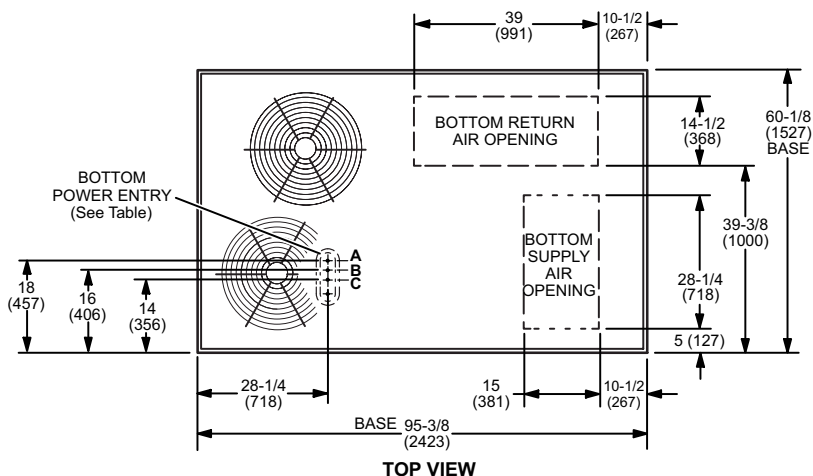

## ⚠ CAUTION

As with any mechanical equipment, contact with sharp sheet metal edges can result in personal injury. Take care while handling this equipment and wear gloves and protective clothing.

### Shipping and Packing List

#### Package 1 of 1 contains:

1- Assembled unit

Check unit for shipping damage. Receiving party should contact last carrier immediately if shipping damage is found.

### General

These instructions are intended as a general guide and do not supersede local codes in any way. Authorities having jurisdiction should be consulted before installation.

The ZH packaged rooftop units are available in 7-1/2, 8-1/2 and 10 ton cooling capacities. Optional electric heat is available.

Units are available with an optional supply air inverter. During cooling, the blower will operate at lower speeds when demand is low and increase to higher speeds when demand is high. During a blower only demand, the blower will operate at low speed. During a heating demand, the blower will operate at high speed.

Availability of units and options varies by brand.

### Safety

See figure 1 for unit clearances.

Use of this unit as a construction heater or air conditioner is not recommended during any phase of construction. Very low return air temperatures, harmful vapors and operation of the unit with clogged or misplaced filters will damage the unit.

## ⚠ IMPORTANT

The Clean Air Act of 1990 bans the intentional venting of refrigerant (CFC's and HCFC's) as of July 1, 1992. Approved methods of recovery, recycling or reclaiming must be followed. Fines and/or incarceration may be levied for non-compliance.

## ⚠ WARNING



Electric shock hazard and danger of explosion. Can cause injury, death or product or property damage. Turn off electrical power to unit before performing any maintenance or servicing operations on the unit. Follow lighting instructions attached to unit when putting unit back into operation and after service or maintenance.

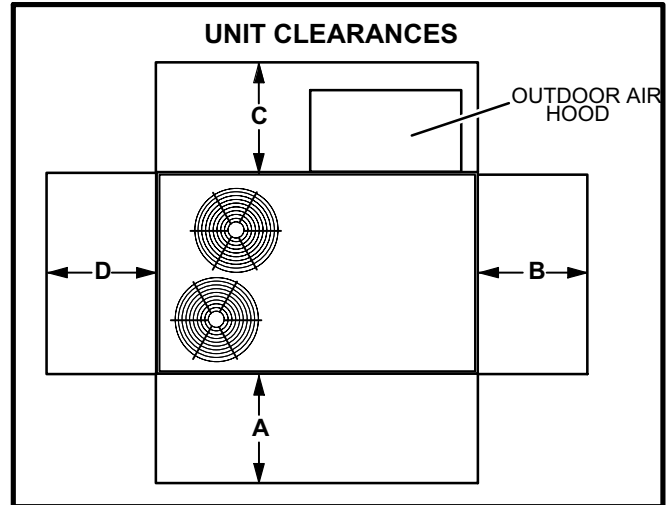

FIGURE 1

<sup>1</sup> Unit Clearance	A in.(mm)	B in.(mm)	C in.(mm)	D in.(mm)	Top Clearance
Service Clearance	36 (914)	36 (914)	60 (1524)	36 (914)	Unob- structed
Minimum Opera- tion Clearance	36 (914)	36 (914)	60 (1524)	36 (914)	Unob- structed

Note - Entire perimeter of unit base requires support when elevated above mounting surface.

<sup>1</sup> **Service Clearance** - Required for removal of serviceable parts.

**Minimum Operation Clearance** - Required clearance for proper unit operation.

## ⚠ NOTICE

### Roof Damage!

This system contains both refrigerant and oil. Some rubber roofing material may absorb oil, causing the rubber to swell. Bubbles in the rubber roofing material can cause leaks. Protect the roof surface to avoid exposure to refrigerant and oil during service and installation. Failure to follow this notice could result in damage to roof surface.

If this unit has been used for heating or cooling of buildings or structures under construction, the following conditions must be met or the warranty will be void:

- A room thermostat must control the unit. The use of fixed jumpers that will provide continuous heating or cooling is not allowed.
- A pre-filter must be installed at the entry to the return air duct.
- The return air duct must be provided and sealed to the unit.
- Return air temperature range between 55°F (13°C) and 80°F (27°C) must be maintained.
- Air filters must be replaced and pre-filters must be removed upon construction completion.
- The input rate and temperature rise must be set per the unit rating plate.
- The heat exchanger, components, duct system, air filters and evaporator coil must be thoroughly cleaned following final construction clean-up.
- The unit operating conditions (including airflow, cooling operation, ignition, input rate, temperature rise and venting) must be verified according to these installation instructions.

## Unit Support

In downflow discharge installations, install the unit on a non-combustible surface only. Unit may be installed on combustible surfaces when used in horizontal discharge applications or in downflow discharge applications when installed on an Z1CURB roof mounting frame.

*NOTE - Securely fasten roof frame to roof per local codes.*

### A-Downflow Discharge Application

#### Roof Mounting with Z1CURB

- 1- The Z1CURB roof mounting frame must be installed, flashed and sealed in accordance with the instructions provided with the frame.
- 2- The Z1CURB roof mounting frame should be square and level to 1/16" per linear foot (5mm per linear meter) in any direction.
- 3- Duct must be attached to the roof mounting frame and not to the unit; supply and return plenums must be installed before setting the unit.

### Installer's Roof Mounting Frame

Many types of roof frames can be used to install the unit depending upon different roof structures. Items to keep in mind when using the building frame or supports are:

- 1- The base is fully enclosed and insulated, so an enclosed frame is not required.
- 2- The frames or supports must be constructed with non-combustible materials and should be square and level to 1/16" per linear foot (5mm per linear meter) in any direction.
- 3- Frame or supports must be high enough to prevent any form of moisture from entering unit. Recommended minimum frame height is 14" (356mm).
- 4- Duct must be attached to the roof mounting frame and not to the unit. Supply and return plenums must be installed before setting the unit.
- 5- Units require support along all four sides of unit base. Supports must be constructed of steel or suitably treated wood materials.

*NOTE-When installing a unit on a combustible surface for downflow discharge applications, an Z1CURB roof mounting frame is required.*

### B-Horizontal Discharge Applications

- 1- Specified installation clearances must be maintained when installing units. Refer to figure 1.
- 2- Top of support slab should be approximately 4" (102mm) above the finished grade and located so no run-off water from higher ground can collect around the unit.
- 3- Units require support along all four sides of unit base. Supports must be constructed of steel or suitably treated wood materials.

## Duct Connection

All exterior ducts, joints and openings in roof or building walls must be insulated and weather-proofed with flashing and sealing compounds in accordance with applicable codes. Any duct passing through an unconditioned space must be insulated.

## CAUTION

**In downflow applications, do not drill or punch holes in base of unit. Leaking in roof may occur if unit base is punctured.**

## Rigging Unit For Lifting

Rig unit for lifting by attaching four cables to holes in unit base rail. See figure 2.

- 1- Detach wooden base protection before rigging.
- 2- Connect rigging to the unit base using both holes in each corner.
- 3- All panels must be in place for rigging.
- 4- Place field-provided H-style pick in place just above top edge of unit. Frame must be of adequate strength and length. (H-style pick prevents damage to unit.)
- 5- **All Units** - Partially lift unit and remove five (5) L-brackets which secure the protective base board. See figure 2.

**Important - Protective wooden base board must be removed before setting unit.**

- 6- **New roof curbs (89-3/8" in length)** - Remove the three alignment brackets shown in figure 3.
- 7- **Existing roof curbs (81-3/4" in length)** - Set unit on roof curb positioning alignment brackets as shown in figure 3.

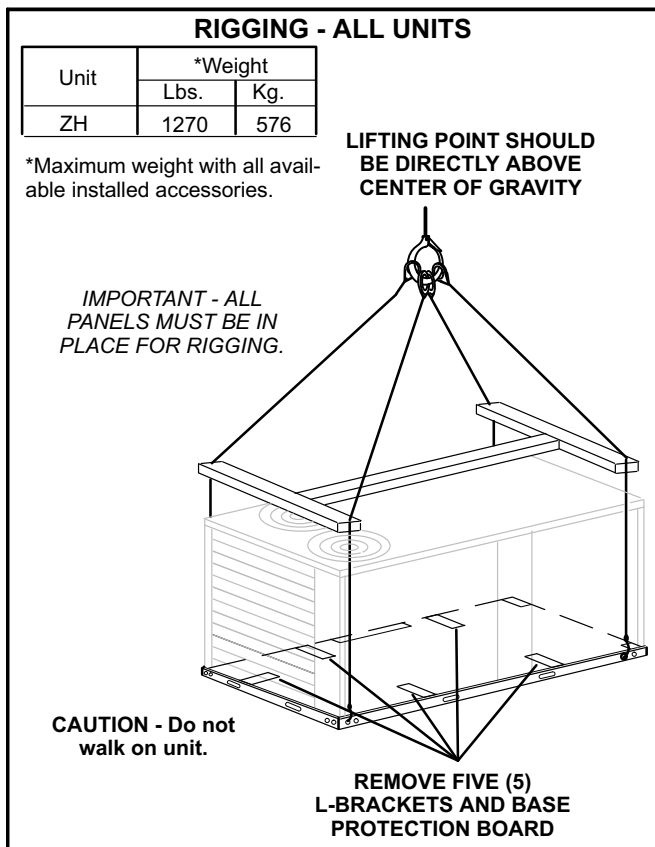

FIGURE 2

## UNIT ALIGNMENT BRACKETS

### NEW ROOF CURBS (89-3/8" IN LENGTH):

Remove all three brackets.

### EXISTING ROOF CURBS (81-3/4" LONG):

Set unit on roof curb positioning alignment brackets as shown.

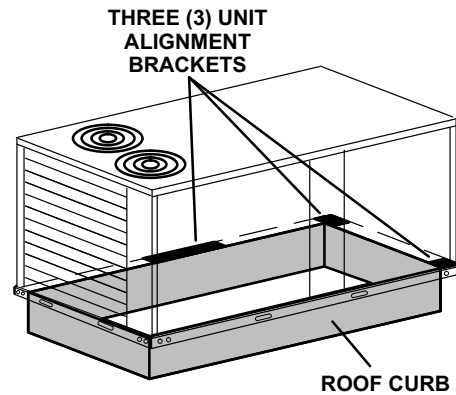

FIGURE 3

## Condensate Drains

Make drain connection to the 1" N.P.T. drain coupling provided on unit.

*Note - The drain pan is made with a glass reinforced engineered plastic capable of withstanding typical joint torque but can be damaged with excessive force. Tighten pipe nipple hand tight and turn an additional quarter turn.*

A trap must be installed between drain connection and an open vent for proper condensate removal. See figure 4. It is sometimes acceptable to drain condensate onto the roof or grade; however, a tee should be fitted to the trap to direct condensate downward. The condensate line must be vented. Check local codes concerning condensate disposal. Refer to page 2 for condensate drain location.

Units are shipped with the drain coupling facing the right side of the unit. The unit can be installed in either downflow or horizontal air discharge regardless of condensate drain location.

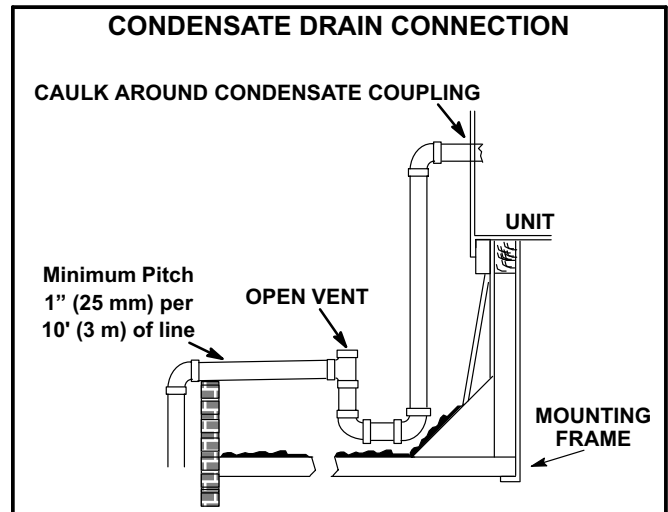

FIGURE 4

## Electrical Connections

### POWER SUPPLY

Do not apply power or close disconnect switch until installation is complete. Refer to start-up directions. Refer closely to unit wiring diagram.

Refer to unit nameplate for minimum circuit ampacity and maximum fuse size.

- 1- 230/460/575 volt units are factory wired. **For 208V supply**, disconnect the pink wire (230V) at all control power transformer(s). Reconnect the pink wire (208V). Tape the exposed end of the 230V pink wire.
- 2- Route power through the bottom power entry area and connect to L1, L2, and L3 on the bottom of TB13 in control box. Route power to S48 disconnect switch when the option is factory-installed. See unit wiring diagram.

### CONTROL WIRING

#### A-Thermostat Location

Room thermostat mounts vertically on a standard 2" X 4" handy box or on any non-conductive flat surface.

Locate thermostat approximately 5 feet (1524mm) above the floor in an area with good air circulation at average temperature. Avoid locating the room thermostat where it might be affected by:

- drafts or dead spots behind doors and in corners
- hot or cold air from ducts
- radiant heat from sun or appliances
- concealed pipes and chimneys

#### B-Control Wiring

- 1- Route thermostat cable or wires from subbase to control box (refer to unit dimensions to locate bottom and side power entry).

**IMPORTANT** - Unless field thermostat wires are rated for maximum unit voltage, they must be routed away from line voltage wiring. Use wire ties located near the lower left corner of the controls hat section to secure thermostat cable.

Use 18 AWG wire for all applications using remotely installed electro-mechanical and electronic thermostats.

- 2- Install thermostat assembly in accordance with instructions provided with thermostat.

- 3- Connect thermostat wiring to TB1 terminal board on the left side of the controls area. Wire as shown in figure 5 for electro-mechanical and electronic thermostats. If using other temperature control devices or energy management systems see instructions and wiring diagram provided by manufacturer.

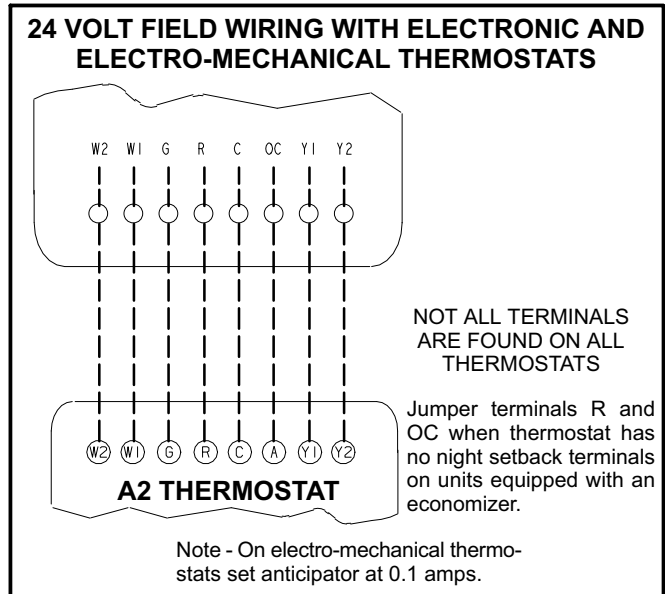

**FIGURE 5**

**IMPORTANT**-Terminal connections at the wall plate or subbase must be made securely. Loose control wire connections may allow unit to operate but not with proper response to room demand.

## Unit Power-Up

### A-General

- 1- Make sure that unit is installed in accordance with the installation instructions and applicable codes.
- 2- Inspect all electrical wiring, both field- and factory-installed, for loose connections. Tighten as required.
- 3- Check to ensure that refrigerant lines do not rub against the cabinet or against other refrigerant lines.
- 4- Check voltage at main unit power connection. Voltage must be within range listed on nameplate. If not, consult power company and have voltage condition corrected before starting unit.
- 5- Make sure filters are in place before start-up.
- 6- Make sure there is no heating, cooling, or blower demand from thermostat. Apply power to unit.

## Blower Operation and Adjustments

### A-Three Scroll Compressor Voltage Phasing

Three phase scroll compressors must be phased sequentially to ensure correct compressor and blower rotation and operation. Compressor and blower are wired in phase at the factory. Power wires are color-coded as follows: line 1-red, line 2-yellow, line 3-blue.

- 1- Observe suction and discharge pressures and blower rotation on unit start-up.

If pressure differential is not observed or blower rotation is not correct:

- 2- Suction pressure must drop, discharge pressure must rise, and blower rotation must match rotation marking.
- 3- Disconnect all remote electrical power supplies.
- 4- Reverse any two field-installed wires connected to the line side of K3, TB2 or F4. Do not reverse wires at blower contactor or compressors.
- 5- Make sure the connections are tight.

Discharge and suction pressures should operate at their normal start-up ranges.

### B-Blower Operation

Initiate blower demand at thermostat according to instructions provided with thermostat. Unit will cycle on thermostat demand. The following steps apply to applications using a typical electro-mechanical thermostat.

- 1- Blower operation is manually set at the thermostat subbase fan switch. With fan switch in **ON** position, blowers will operate continuously.
- 2- With fan switch in **AUTO** position, the blowers will cycle with demand. Blowers and entire unit will be off when system switch is in **OFF** position.

### C-Blower Access

The blower assembly is secured to a sliding frame which allows the blower motor to be pulled out of the unit. See figure 6.

- 1- Loosen the reusable wire tie which secures the blower wiring to the blower motor mounting plate.
- 2- Remove and retain screws on either side of sliding frame. Pull frame toward outside of unit.
- 3- Slide frame back into original position when finished servicing. Reattach the blower wiring in the previous location on the blower motor base using the wire tie.
- 4- Replace retained screws on either side of the sliding frame.

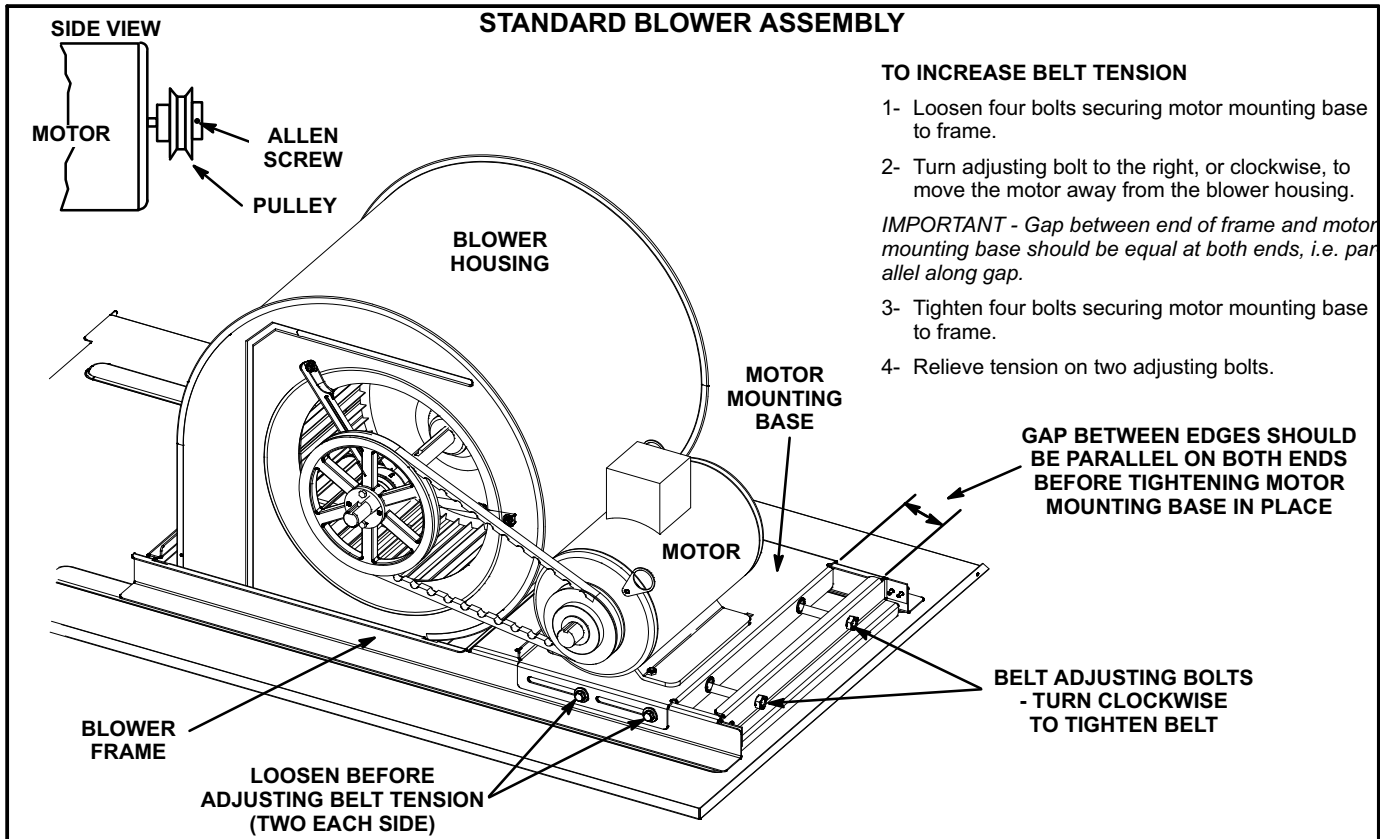

FIGURE 6

## D-Determining Unit CFM

- 1- The following measurements must be made with a dry indoor coil and air filters in place.

*Units **Not** Equipped With An Inverter -*  
Run blower without a cooling demand.

*Units Equipped With An Inverter -*  
Initiate high speed blower without a cooling demand. Disconnect high pressure switches S4 and S7. Run the blower with Y1 **and** Y2 demands.

- 2- Measure the indoor blower shaft RPM.
- 3- With all access panels in place, measure static pressure external to unit (from supply to return). Blower performance data is based on static pressure readings taken in locations shown in figure 7.

*Note - Static pressure readings can vary if not taken where shown.*

- 4- Referring to page 10 or 11, use static pressure and RPM readings to determine unit CFM. Use page 12 when installing units with any of the optional accessories listed.
- 5- The blower RPM can be adjusted at the motor pulley. Loosen Allen screw and turn adjustable pulley clockwise to increase CFM. Turn counterclockwise to decrease CFM. See figure 6. Do not exceed minimum and maximum number of pulley turns as shown in table 1.
- 6- *Units Equipped With An Inverter -*  
Reconnect high pressure switches S4 and S7.

**TABLE 1**  
**MINIMUM AND MAXIMUM PULLEY ADJUSTMENT**

Belt	Minimum Turns Open	Maximum Turns Open
A Section	0	5
B Section	1*	6

\*No minimum number of turns open when B belt is used on pulleys 6" O.D. or larger.

## E-Blower Belt Adjustment

Maximum life and wear can be obtained from belts only if proper pulley alignment and belt tension are maintained. Tension new belts after a 24-48 hour period of operation. This will allow belt to stretch and seat in the pulley grooves. Make sure blower and motor pulleys are aligned as shown in figure 8.

- 1- Loosen four bolts securing motor base to mounting frame. See figure 6.
- 2- *To increase belt tension -*  
Turn both adjusting bolts to the right, or clockwise, to move the motor outward and tighten the belt. This increases the distance between the blower motor and the blower housing.  
*To loosen belt tension -*  
Turn the adjusting bolts to the left, or counterclockwise to loosen belt tension.

**IMPORTANT -** Align top edges of blower motor base and mounting frame base parallel before tightening two bolts on the other side of base. Motor shaft and blower shaft must be parallel.

- 3- Tighten two bolts on each side of the motor mounting base. This secures the mounting base to the frame.

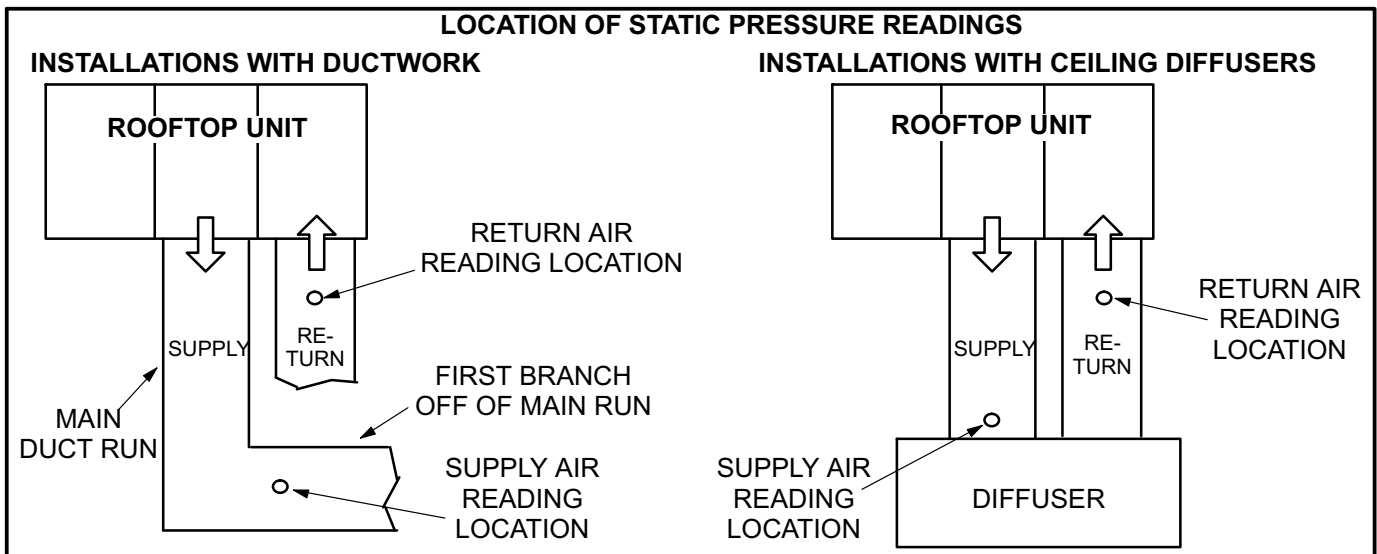

**FIGURE 7**



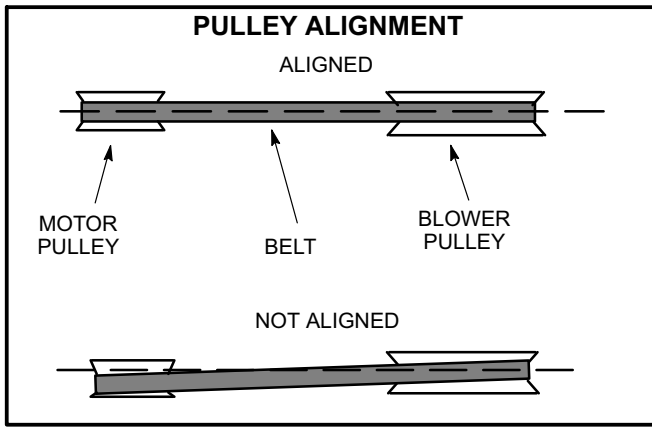

**FIGURE 8**

**F-Check Belt Tension**

Overtensioning belts shortens belt and bearing life. Check belt tension as follows:

- 1- Measure span length X. See figure 9.
- 2- Apply perpendicular force to center of span (X) with enough pressure to deflect belt 1/64" for every inch of span length or 1.5mm per 100mm of span length.
 

Example: Deflection distance of a 40" span would be 40/64" or 5/8".

Example: Deflection distance of a 400mm span would be 6mm.

- 3- Measure belt deflection force. For a new 2 and 3hp belt, the deflection force should be 5.0-7.0 lbs. (35-48kPa). For a new 5hp belt, the deflection force should be 7-10lbs. (48-69kPa).

A force below these values indicates an undertensioned belt. A force above these values indicates an overtensioned belt.

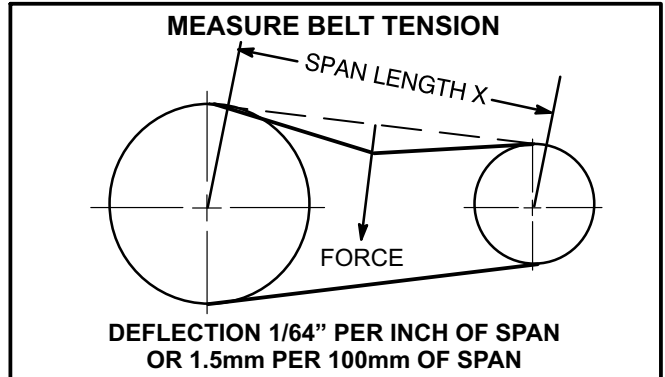

**FIGURE 9**

**F-Field-Furnished Blower Drives**

For field-furnished blower drives, use pages 10 through 12 to determine BHP and RPM required. Reference table 2 for drive component manufacturer's numbers.

**TABLE**  
**ZHA092S BASE UNIT BLOWER PERFORMANCE**

**ZHA 102H & 150 BASE UNIT BLOWER PERFORMANCE**

**ZHA  
DRIVE KIT SPECS  
PEF PERFORMANCE  
AIR RESISTANCE**

**TABLE 2  
MANUFACTURER'S NUMBERS**

DRIVE NO.	DRIVE COMPONENTS					
	ADJUSTABLE SHEAVE		FIXED SHEAVE		BELT	
	BROWNING NO.	OEM PART NO.	BROWNING NO.	OEM PART NO.	BROWNING NO.	OEM PART NO.
1	1VP34x7/8	31K6901	AK61x1	100244-20	A44	44L5501
2	1VP40x7/8	79J0301	AK59x1	31K6801	AX45	100245-23
3	1VP34x7/8	31K6901	AK46x1	100244-17	A41	100245-18
4	1VP44x7/8	P-8-1488	AK74x1	100244-21	AX48	100245-50
5	1VP50x7/8	P-8-2187	AK69x1	37L4701	AX48	100245-50
6	1VP50x7/8	P-8-2187	AK64x1	12L2501	AX46	31K7101
10	1VP50x1-1/8	P-8-1977	BK77x1	49K4001	BX50	100245-49
11	1VP50x1-1/8	P-8-1977	BK67x1	100244-24	BX46	100245-48
12	1VP50x1-1/8	P-8-1977	BK62x1	100244-23	BX46	100245-48

### Heating Start-Up

- 1- Set thermostat or temperature control device to initiate a first-stage heating demand.

A first-stage heating demand (W1) will energize compressors 1 and 2. Both outdoor fans are energized with a W1 demand.

*Note - L1 and L2 reversing valves are de-energized in the heating mode.*

#### *KHA Units With Optional Electric Heat -*

An increased heating demand (W2) will energize electric heat. Electric heat is also energized during the defrost cycle (W1) to maintain discharge air temperature.

### Cooling Start-Up

#### A-Operation

*Supply Air Inverter Units - Refer to the Supply Air Inverter Start-Up section.*

- 1- Initiate first and second stage cooling demands according to instructions provided with thermostat.
- 2- *No Economizer Installed in Unit -*  
A first-stage cooling demand (Y1) will energize compressor 1 and both condenser fans. An increased cooling demand (Y2) will energize compressor 2.

#### *Units Equipped With Economizer -*

When outdoor air is acceptable, a first-stage cooling demand (Y1) will energize the economizer. An increased cooling demand (Y2) will energize compressor 1 and both condenser fans. When outdoor air is not acceptable unit will operate as though no economizer is installed.

- 3- Units contain two refrigerant circuits or stages. See figure 10.

- 4- Each refrigerant circuit is separately charged with R-410A refrigerant. See unit rating plate for correct amount of charge.

- 5- Refer to Cooling Operation and Adjustment section for proper method to check refrigerant charge.

#### B-Refrigerant Charge and Check - Fin/Tube Coil

**WARNING-Do not exceed nameplate charge under any condition.**

This unit is factory charged and should require no further adjustment. If the system requires additional refrigerant, reclaim the charge, evacuate the system, and add required nameplate charge.

*NOTE - System charging is not recommended below 60°F (15°C). In temperatures below 60°F (15°C), the charge **must** be weighed into the system.*

If weighing facilities are not available, or to check the charge, use the following procedure:

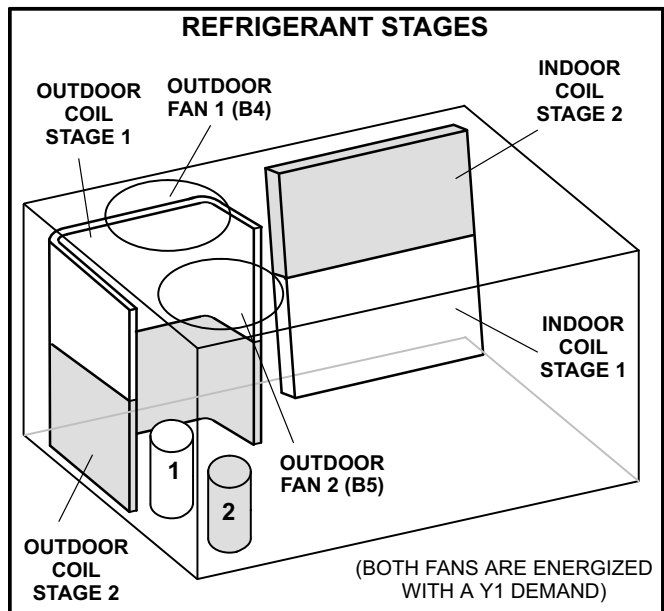

**FIGURE 10**

## IMPORTANT - Charge unit in standard cooling mode.

- 1- Make sure outdoor coil is clean. Attach gauge manifolds and operate unit at full CFM in cooling mode with economizer disabled until system stabilizes (approximately five minutes). Make sure all outdoor air dampers are closed.
- 2- Check each system separately with all stages operating. Compare the normal operating pressures (see tables 3 - 5) to the pressures obtained from the gauges. Check unit components if there are significant differences.
- 3- Measure the outdoor ambient temperature and the suction pressure. Refer to the appropriate circuit charging curve to determine a target liquid temperature.

*Note - Pressures are listed for sea level applications.*

- 4- Use the same thermometer to accurately measure the liquid temperature (in the outdoor section).
  - If measured liquid temperature is higher than the target liquid temperature, add refrigerant to the system.
  - If measured liquid temperature is lower than the target liquid temperature, recover some refrigerant from the system.
- 5- Add or remove charge in increments. Allow the system to stabilize each time refrigerant is added or removed.
- 6- Continue the process until measured liquid temperature agrees with the target liquid temperature. Do not go below the target liquid temperature when adjusting charge. Note that suction pressure can change as charge is adjusted.
- 7- Example ZH 092S Circuit 1: At 95°F outdoor ambient and a measured suction pressure of 130psig, the target liquid temperature is 103°F. For a measured liquid temperature of 106°F, add charge in increments until measured liquid temperature agrees with the target liquid temperature.

## C-Compressor Controls

- 1- High Pressure Switches (S4, S7)  
Compressor circuits are protected by a high pressure switch which cuts out at 640 psig  $\pm$  10 psig (4413 kPa  $\pm$  70 kPa).
- 2- High Temperature Limit Switches (S5, S8)  
Switches de-energize compressors when the temperature on top of the compressor exceeds 248°F (120°C). Switches reset when temperature cools to 169°F (76°C).
- 3- Defrost Switches (S6, S9)  
Defrost switches close to initiate defrost when liquid line temperature falls to 35°F (1.7°C). The defrost switch is located on the liquid line between the outdoor expansion valve and the distributor
- 4- Defrost Termination Switch (S104)  
Defrost pressure switch opens to terminate defrost when vapor (discharge pressure during cooling and defrost) pressure reaches 450 psig (3103 kPa).
- 5- Defrost Controls (CMC1)  
Defrost is liquid line temperature initiated and operates for 14 minutes unless terminated by vapor line pressure drop.

When the liquid line temperature drops below 35°F, the defrost switch closes and signals the **defrost control** that a defrost cycle is needed. If the defrost switch is still closed after 60 minutes (default), a defrost cycle begins and operates for 14 minutes. The defrost pressure switch can terminate the defrost cycle before the 14 minutes elapses if vapor pressure reaches 450  $\pm$  10 psi.

Electric heat is energized during defrost to maintain discharge air temperature.

**TABLE 3**

**092S Normal Operating Pressures**

	Outdoor Coil Entering Air Temperature											
	65 °F		75 °F		85 °F		95 °F		105 °F		115 °F	
	Suct (psig)	Disc (psig)	Suct (psig)	Disc (psig)	Suct (psig)	Disc (psig)	Suct (psig)	Disc (psig)	Suct (psig)	Disc (psig)	Suct (psig)	Disc (psig)
Circuit 1	95	244	98	285	100	325	104	372	108	424	113	485
	105	251	108	289	112	337	115	385	118	436	121	492
	110	253	118	297	126	346	128	398	136	450	135	505
	113	260	122	302	130	351	137	404	144	458	143	515
Circuit 2	119	240	124	281	128	322	131	368	135	419	138	473
	124	244	127	281	131	325	134	371	139	422	144	477
	133	241	142	293	149	338	152	387	158	436	159	488
	136	253	144	291	154	336	162	386	169	436	174	492

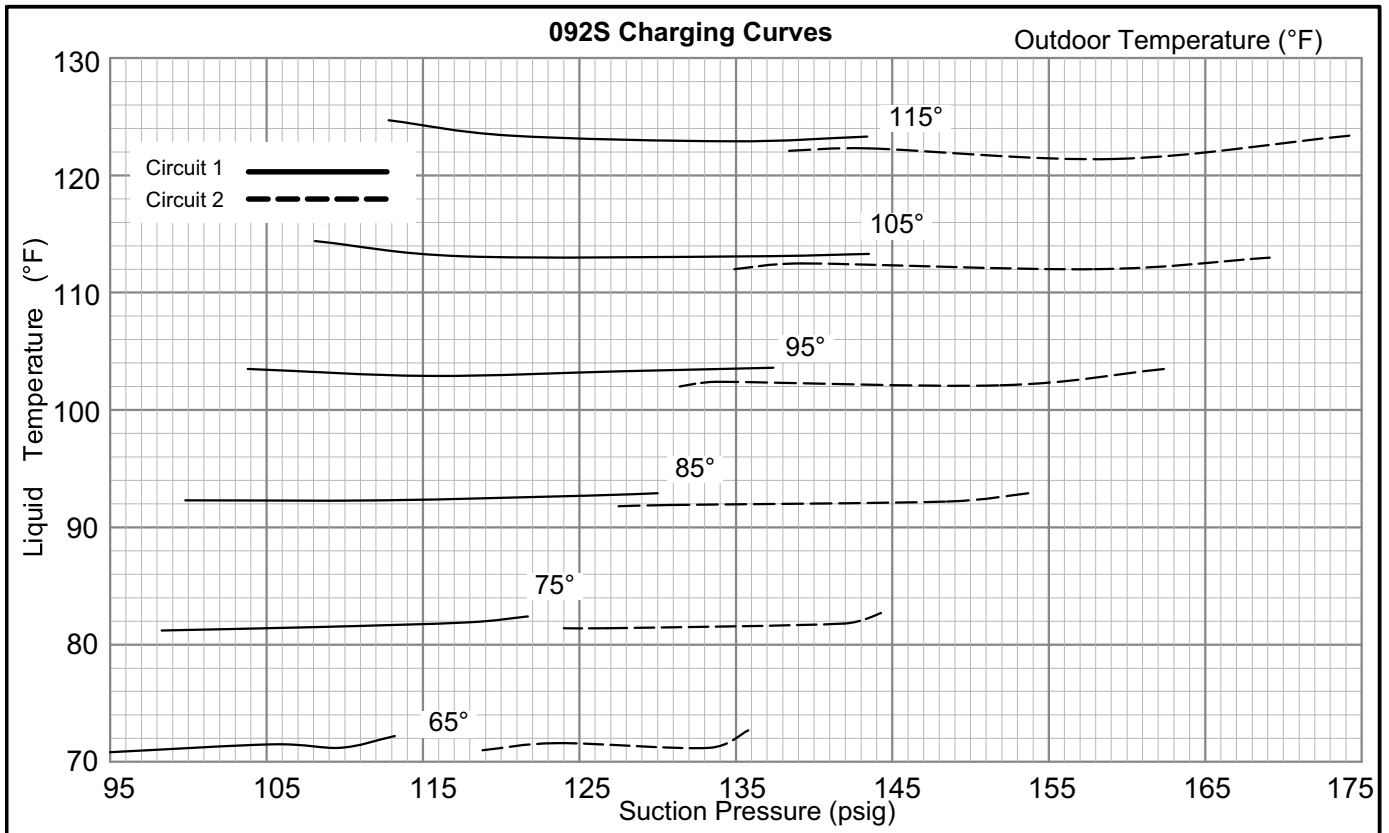

**TABLE 4**

**102S Normal Operating Pressures**

	Outdoor Coil Entering Air Temperature											
	65 °F		75 °F		85 °F		95 °F		105 °F		115 °F	
	Suct (psig)	Disc (psig)	Suct (psig)	Disc (psig)	Suct (psig)	Disc (psig)	Suct (psig)	Disc (psig)	Suct (psig)	Disc (psig)	Suct (psig)	Disc (psig)
Circuit 1	105	250	107	287	111	330	114	375	116	425	120	487
	113	256	117	296	119	337	120	383	121	430	127	491
	124	265	132	309	137	355	141	405	145	459	145	515
	129	268	138	312	146	363	153	415	159	472	160	530
Circuit 2	116	260	119	298	123	340	126	385	131	437	136	405
	125	266	128	306	131	347	137	398	140	447	145	503
	136	271	142	313	148	359	152	409	155	462	157	519
	144	271	152	321	159	370	166	421	171	477	172	534

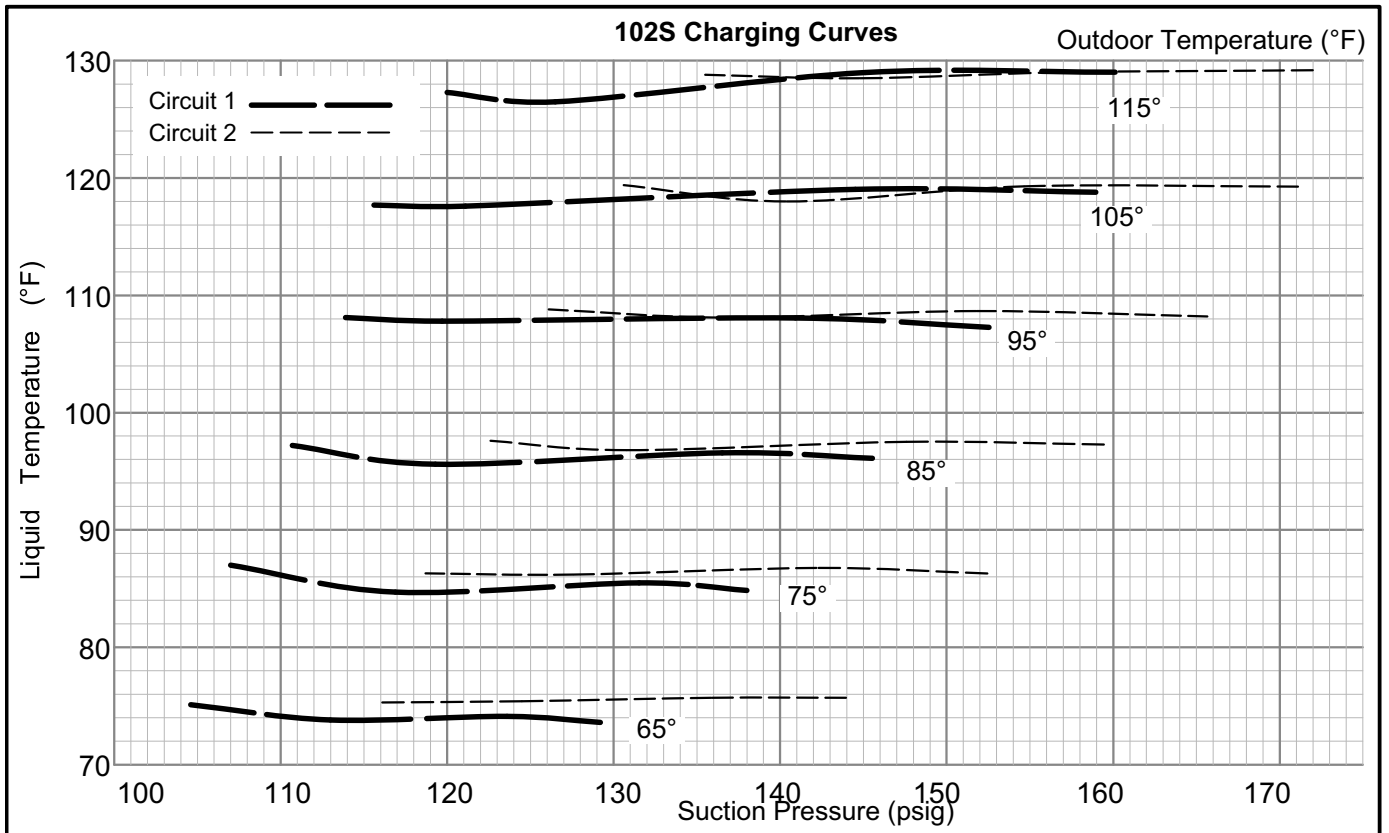



**TABLE 5**

120S Normal Operating Pressures												
	Outdoor Coil Entering Air Temperature											
	65 °F		75 °F		85 °F		95 °F		105 °F		115 °F	
	Suct (psig)	Disc (psig)	Suct (psig)	Disc (psig)	Suct (psig)	Disc (psig)	Suct (psig)	Disc (psig)	Suct (psig)	Disc (psig)	Suct (psig)	Disc (psig)
Circuit 1	107	257	110	294	112	338	115	384	119	436	121	493
	113	261	117	302	119	342	122	387	125	438	128	492
	124	268	128	309	135	356	140	406	144	458	146	512
	133	274	141	319	148	366	153	417	161	474	161	531
Circuit 2	114	265	115	302	119	345	122	390	125	443	130	496
	121	269	125	310	127	354	131	401	134	448	137	498
	132	279	140	319	145	365	148	414	152	469	155	524
	137	284	147	329	155	379	163	430	171	486	171	539

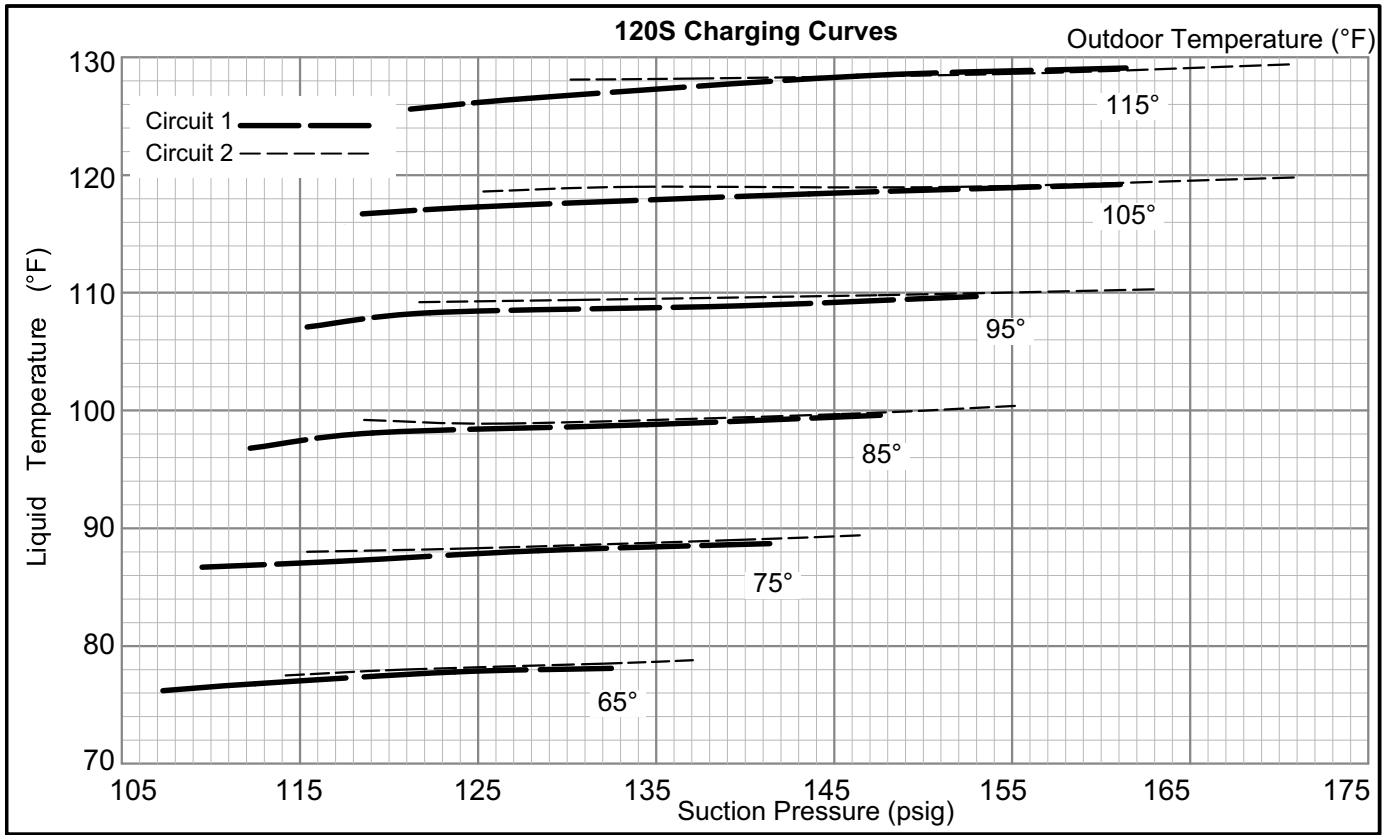

**Electric Heat Start-Up**

Optional electric heat will stage on and cycle with thermostat demand. Number of stages of electric heat will vary depending on electric heat assembly. See electric heat wiring diagram on unit for sequence of operation.

## Defrost Control Board

The defrost thermostat, defrost pressure switch and the defrost control work together to ensure that the heat pump outdoor coil does not ice excessively during the heating mode.

### Compressor Accumulated Run-Time Interval

The defrost control will not energize a defrost cycle unless the unit has been operating in heating mode for an accumulated 60 minutes (default) on 100269-02 boards; 90 minutes (default) on 100269-04 boards. The run time interval can be changed by moving the jumper on the CMC board timing pins. See figure 11.

The defrost interval can be adjusted to 30, 60, or 90 minutes. The defrost timing jumper is factory-installed to provide a 60-minute defrost interval. If the timing selector jumper is not in place, the control defaults to a 90-minute defrost interval.

### Defrost Test Option

A TEST option is provided for troubleshooting. The TEST mode may be started any time the unit is in the heating mode and the defrost thermostat is closed or jumpered. If the timing jumper is in the TEST position at power-up, the

defrost control will ignore the test pins. When the jumper is placed across the TEST pins for two seconds, the control will enter the defrost mode. If the jumper is removed before an additional 5-second period has elapsed (7 seconds total), the unit will remain in defrost mode until the defrost pressure switch opens or 14 minutes have passed. If the jumper is not removed until after the additional 5-second period has elapsed, the defrost will terminate and the test option will not function again until the jumper is removed and re-applied.

### Diagnostic LEDs

The defrost board uses two LEDs for diagnostics. The LEDs flash a sequence according to the condition.

**TABLE 6**

Defrost Control Board Diagnostic LED		
Indicates	LED 1	LED 2
Normal operation / power to board	Synchronized Flash with LED 2	Synchronized Flash with LED 1
Board failure / no power	Off	Off
Board failure	On	On
Anti-short cycle lockout	Alternating slow flash	

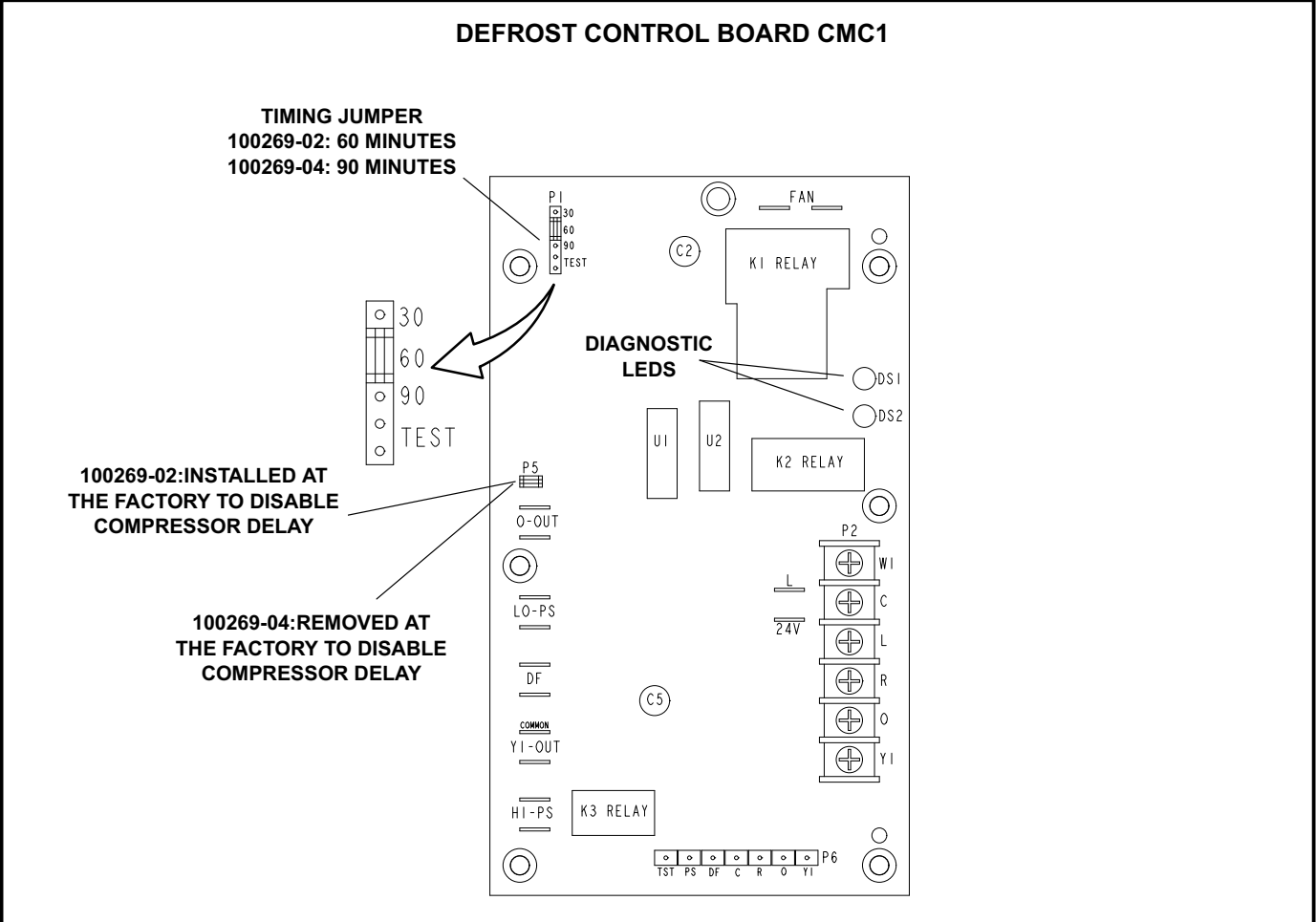

**FIGURE 11**

## Service

The unit should be inspected once a year by a qualified service technician.

### **⚠ CAUTION**

Label all wires prior to disconnection when servicing controls. Wiring errors can cause improper and dangerous operation. Verify proper operation after servicing.

### **⚠ WARNING**

This product contains a chemical known to the State of California to cause cancer, birth defects, or other reproductive harm.

#### A-Filters

Units are equipped with 20 X 24 X 2" temporary filters which must be replaced prior to building occupation. Refer to local codes or appropriate jurisdiction for approved filters.

To change filters, open filter access panel on back side of unit. See figure 12. Lift filter stop to remove filters. See figure 13.

### **⚠ WARNING**

Units are shipped from the factory with temporary filters. Replace filters before building is occupied. Damage to unit could result if filters are not replaced with approved filters. Refer to appropriate codes.

Approved filters should be checked monthly and replaced when necessary. Take note of air flow direction marking on filter frame when reinstalling filters. See figure 13.

*NOTE-Filters must be U.L.C. certified or equivalent for use in Canada.*

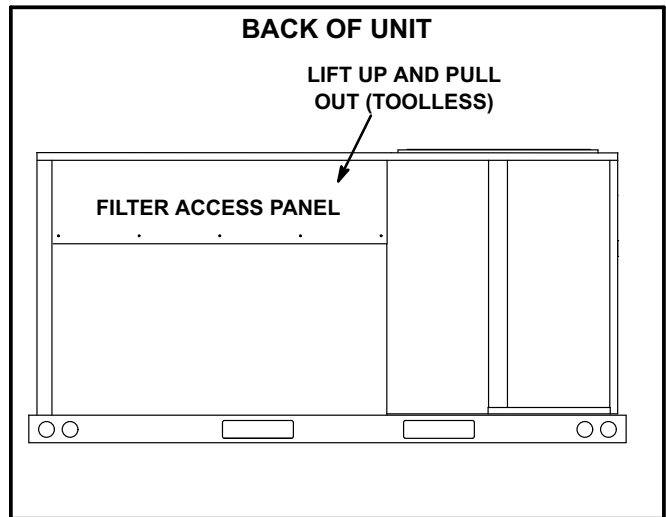

FIGURE 12

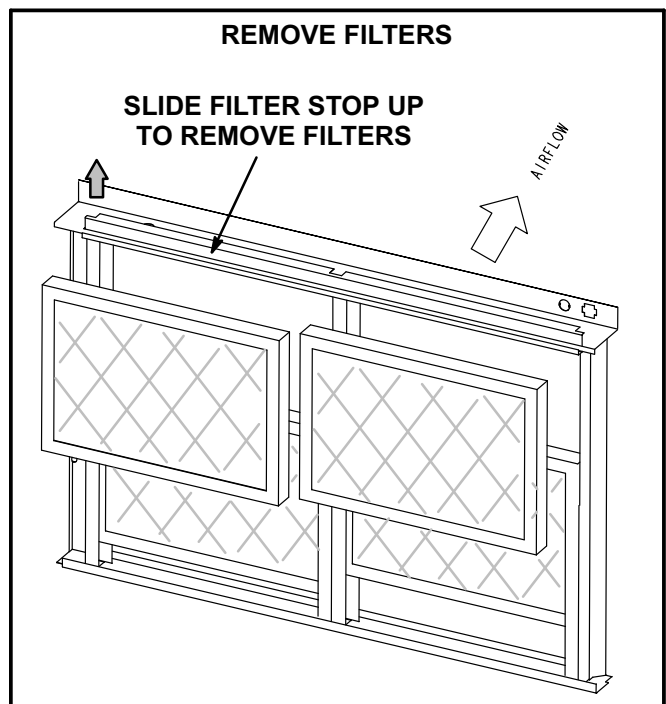

FIGURE 13

#### B-Lubrication

All motors are lubricated at the factory. No further lubrication is required.

### C-Indoor Coil

Inspect and clean coil at beginning of each cooling season. Clean using mild detergent or commercial coil cleaner. Flush coil and condensate drain with water taking care not to get insulation, filters and return air ducts wet.

### D-Outdoor Coil

Clean outdoor coil annually with detergent or commercial coil cleaner and inspect monthly during the cooling season.

Outdoor coils are made of single and two formed slabs.

On units with two slabs, dirt and debris may become trapped between the slabs. To clean between slabs, carefully separate coil slabs and wash them thoroughly. See figure 14. Flush coils with water following cleaning.

*Note - Remove all screws and gaskets prior to cleaning procedure and replace upon completion.*

### E-Supply Air Blower Wheel

Annually inspect supply air blower wheel for accumulated dirt or dust. Turn off power before attempting to remove access panel or to clean blower wheel.

### F-Filter Drier

The unit is equipped with a biflow filter drier. If replacement is necessary, order another of like design.

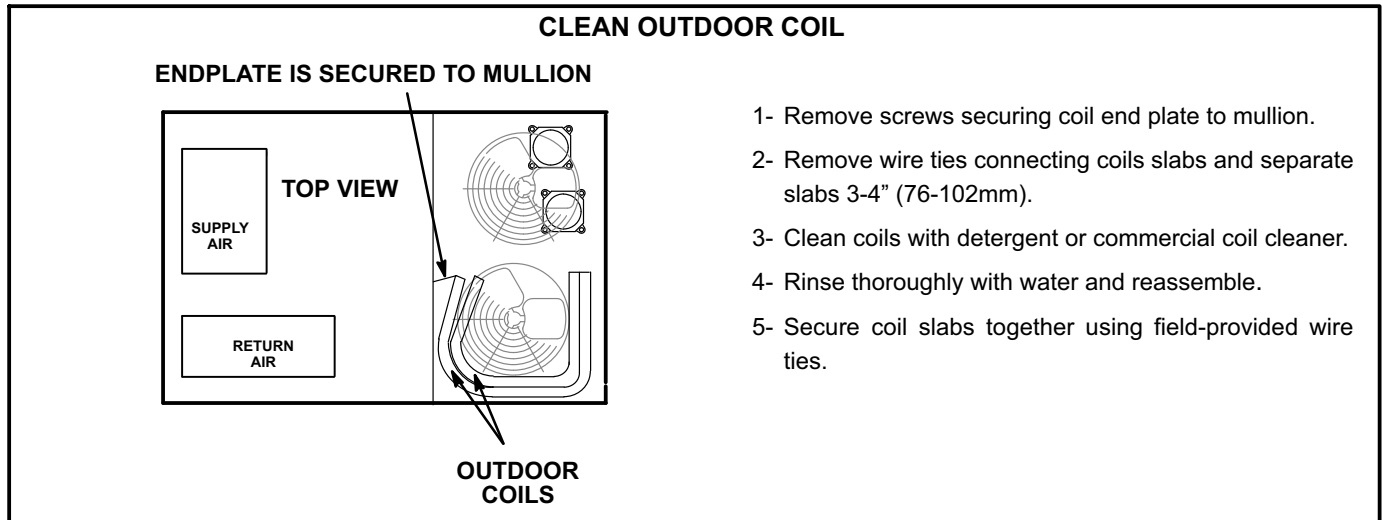

**FIGURE 14**