

PRODUCT SPECIFICATIONS

Bulletin No. ELP-090-120 (3/2018)



EER up to 11.0
7.5 to 10 Tons
Cooling Capacity - 89,000 to 115,000 Btuh
Heating Capacity - 88,000 to 114,000 Btuh

MODEL NUMBER IDENTIFICATION

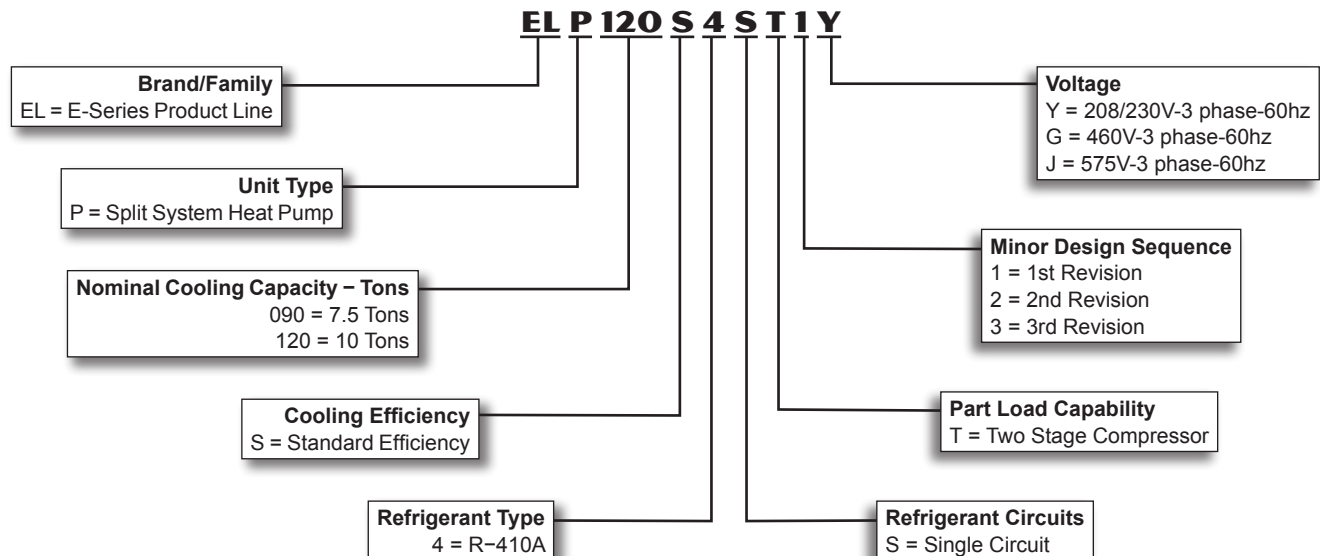

FEATURES AND BENEFITS

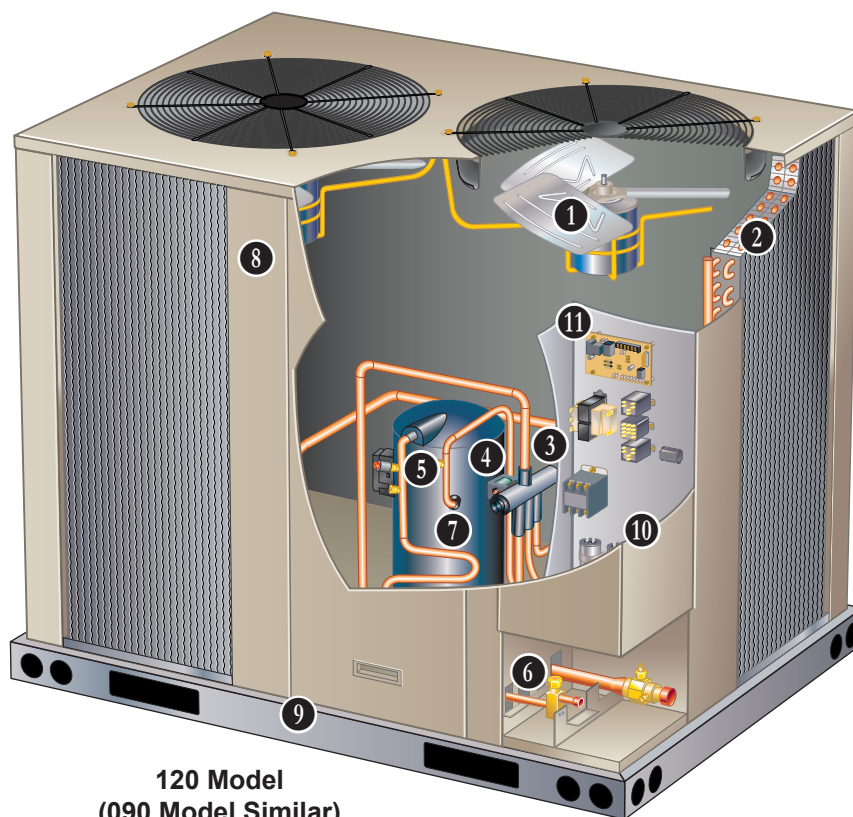

**120 Model
(090 Model Similar)**

CONTENTS

AHRI System Matches	8
Dimensions	9
Electrical Data.....	6
Features And Benefits	2
Model Number Identification	1
Options / Accessories	7
Ratings.....	10
Sound Data	6
Specifications	6
Unit Clearances	8
Weight Data	8

EQUIPMENT WARRANTY

Compressor - Limited warranty for five years in non-residential applications.

All other covered components - One year in non-residential applications.
Refer to Allied Equipment Limited Warranty certificate for specific details.

APPLICATIONS

Heat pumps are available in 7.5 and 10 ton nominal sizes.

Matching air handlers provide a wide range of cooling capacities and applications. See AHRI Ratings tables. See Air Handlers sections for air handler data.

Units shipped completely factory assembled, piped, and wired. Each unit is test operated at the factory insuring proper operation.

Installer must set heat pump, connect refrigerant lines, add refrigerant charge and make electrical connections to complete job.

APPROVALS

All units tested in an ETL certified environmental testing facility.

AHRI Certified to AHRI Standard 340/360-2015.

Sound tested in accordance with test conditions included in AHRI Standard 270 or 370.

Units and components within are bonded for grounding to meet safety standards for servicing required by UL, ULC, NEC and CEC.

All units are ETL listed.

ISO 9001 Registered Manufacturing Quality System.

All units meet two-stage requirements of ASHRAE 90.1, IECC 2015, and California Code of Regulations, Title 24.

FEATURES AND BENEFITS

REFRIGERATION SYSTEM

Refrigerant

Units operate with chlorine-free, ozone friendly, R-410A (field furnished).

1 Outdoor Coil Fan(s)

Dual direct drive fan(s) moves large volumes of air uniformly through entire condenser coil(s) for high refrigerant cooling capacity.

Upward discharge of air reduces operating sound levels and prevents damage to lawns, shrubs, and walkways.

Fan motors are totally enclosed, overload protected and equipped with a rain shield.

Fan service access is accomplished by removal of fan guards.

2 Copper Tube/Enhanced Fin Coil(s)

ELP090S has a single "U" shaped coil.

ELP120S has two "L" shaped coils.

Coils are constructed of precisely spaced ripple-edge aluminum fins machine fitted to seamless copper tubes.

Lanced fins provide maximum exposure of fin surface to air stream resulting in excellent heat transfer.

Fins equipped with collars that grip tubing for maximum contact area.

Flared shoulder tubing connections and machine brazed silver soldering provide tight, leakproof joints.

Long life copper tubing is corrosion-resistant and easy to field service.

Thoroughly factory tested under high pressure to ensure leakproof construction.

Completely accessible for cleaning.

3 Reversing Valve

Factory installed 4-way reversing valve provides rapid change in refrigerant flow direction resulting in quick changeover from cooling to heating and vice-versa.

Valve operates on pressure differential between outdoor unit and indoor unit.

4 High Pressure Switch

Shuts off unit if abnormal operating conditions cause discharge pressure to rise above setting.

Protects the compressor from excessive condensing pressure.

Manual reset.

5 Loss of Charge Switch

Provides loss of charge and freeze-up protection.

Hi-Capacity Drier(s)

Drier traps moisture or dirt that could contaminate the refrigerant system.

6 Refrigerant Lines and Service Valves

Sweat connections.

Fully serviceable liquid and suction line service valves provide complete service access to refrigerant system.

Suction valve can be fully shut off, while liquid valve can be front seated to manage refrigerant charge while servicing system.

Refrigerant lines and field wiring inlets are located in one central area of the unit cabinet.

7 COMPRESSORS

All models feature a single two-stage scroll compressor.

Compressor features high efficiency with uniform suction flow, constant discharge flow and high volumetric efficiency and quiet operation.

Compressor consists of two involute spiral scrolls matched together to generate a series of crescent shaped gas pockets between them.

During compression, one scroll remains stationary while the other scroll orbits around it.

Gas is drawn into the outer pocket, the pocket is sealed as the scroll rotates.

As the spiral movement continues, gas pockets are pushed to the center of the scrolls. Volume between the pockets is simultaneously reduced.

When pocket reaches the center, gas is now high pressure and is forced out of a port located in the center of the fixed scrolls.

During compression, several pockets are compressed simultaneously resulting in a smooth continuous compression cycle.

Continuous flank contact, maintained by centrifugal force, minimizes gas leakage and maximizes efficiency.

Scroll compressor is tolerant to the effects of slugging and contaminants. If this occurs, scrolls separate, allowing liquid or contaminants to be worked toward the center and discharged.

Low gas pulses during compression reduces operational sound levels.

Compressor motor is internally protected from excessive current and temperature.

Compressor is installed in the unit on resilient rubber mounts for vibration free operation.

FEATURES AND BENEFITS

COMPRESSORS (continued)

A 24-volt DC solenoid valve inside the compressor controls staging. When the 3-way solenoid is energized

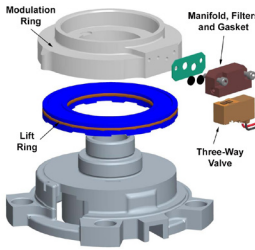

it moves the lift ring assembly to block the ports and the compressor operates at full-load or 100% capacity. When the solenoid is de-energized the lift ring assembly moves to unblock the compressor ports and the compressor operates at part-load

or approximately 67% of its full-load capacity.

The “loading” and “unloading” of the two stage scroll is done “on the fly” without shutting off the single-speed compressor motor between stages.

Crankcase Heater (All Models)

Crankcase heater prevents migration of liquid refrigerant into compressor and ensures proper compressor lubrication at all times.

CABINET

- 8 Heavy-gauge, pre-painted steel cabinet provides superior rust and corrosion protection. Removable panels allow access for unit servicing.
- 9 Heavy duty steel base channels raise the unit off of mounting surface away from damaging moisture. Unit lifting holes and forklift slots furnished in base rails. See dimension drawings.

10 **Control Box**

Control box located in separate compartment in unit cabinet .

All controls are pre-wired at the factory.

Control box is large enough for field installed DDC or other field supplied control modules.

Options/Accessories

Factory Installed

Corrosion Protection

Polymeric epoxy coating that is deposited by electrical transport (electrophoresis), using a process known as electrocoat (e-coat). Available for enhanced coil corrosion protection. Factory installed on the condenser coil. Painted base pan is provided with this option.

Field Installed

Combination Coil/Hail Guards

Heavy gauge steel frame painted to match cabinet with expanded metal mesh to protect the outdoor coil from damage.

ELECTRICAL

Field Installed

GFI Service Outlets (2)

115V ground fault circuit interrupter (GFCI) type, non-powered, field wired.

GFI Weatherproof Cover

Single-gang cover.

Heavy-duty UV-resistant polycarbonate case construction.

Hinged base cover with gasket.

FEATURES AND BENEFITS

CONTROLS

11 Defrost Control

Defrost control includes the combined functions of a time/temperature defrost control, defrost relay, time delay, two diagnostic LEDs (green/red) as an aid in troubleshooting, and a terminal strip for field wiring connections.

Provides a defrost cycle, if needed, every 30, 60 or 90 minutes (adjustable) of compressor “on” time at outdoor coil temperature below 42°F. Defrost thermostat mounted on outdoor coil liquid line determines defrost cycle.

Built-in adjustable compressor delay can be set to allow compressor to cycle off for 30 seconds before and after a defrost cycle.

Five minute timed-off delay short-cycle protection.

Options/Accessories

Field Installed

Low Ambient Control

Heat pumps will operate satisfactorily in cooling mode down to 45°F outdoor air temperature without any additional controls.

Low Ambient Control Kit can be field installed, allowing unit operation down to 0°F using pressure-regulated fan speed control.

Indoor Air Quality (CO₂) Sensors

Monitors CO₂ levels, reports which adjusts economizer dampers as needed.

Thermostat

Thermostat is not furnished with unit and must be ordered extra.

Aftermarket Unit Controller Options

See Options/Accessories table for selection.

THIS PAGE INTENTIONALLY LEFT BLANK

SPECIFICATIONS

General Data		Model No.	ELP090S4S	ELP120S4S
		Nominal Size - Tons	7.5	10
Connections (sweat)	Liquid line - in. (o.d)		5/8	5/8
	Vapor line - in. (o.d)		1-1/8	1-1/8
Refrigerant (R-410A)		Factory installed R-410A holding charge (2 lbs. per stage)		
Field charge (25 ft. line set)			23 lbs. 4 oz. (includes holding charge)	32 lbs. 8 oz. (includes holding charge)
Compressor			(1) Two Stage Scroll	(1) Two Stage Scroll
Outdoor Coil	Net face area - sq. ft. Outer coil		29.3	34.2
	Inner coil		28.4	33.3
	Tube diameter - in. & no. of rows		3/8 - 2	3/8 - 2
	Fins per inch		20	20
Outdoor Coil Fan(s)	Diameter - in. & no. of blades		(2) 24 - 3	(2) 24 - 4
	Motor hp		(2) 1/3	(2) 1/2
	Total air volume - cfm		8300	10,300
	Rpm		1075	1075
	Motor Input - Watts		830	1130

ELECTRICAL DATA

General Data		Line voltage data - 60 hz - 3 phase					
		208/230V	460V	575V	208/230V	460V	575V
² Maximum Overcurrent Protection (amps)		60	25	20	80	35	25
³ Minimum circuit ampacity		37	17	13	50	21	16
Compressor (1)	Rated load amps	26.9	12	9	34.6	14.8	11.1
	Locked rotor amps	165	94	65	240	130	93.7
Outdoor Coil Fan Motor (2) (1 phase)	Full load amps (total)	1.7 (3.4)	0.8 (1.6)	1 (2)	3 (6)	1.5 (3)	1.2 (2.4)
	Locked rotor amps (total)	4.3 (8.6)	2.4 (4.8)	1.9 (3.8)	6 (12)	3 (6)	2.9 (5.8)

NOTE - Extremes of operating range are plus and minus 10% of line voltage.

² HACR type circuit breaker or fuse.

³ Refer to National or Canadian Electrical Code manual to determine wire, fuse and disconnect size requirements.

SOUND DATA

¹ Unit Model No.	Octave Band Linear Sound Power Levels dB, re 10 ⁻¹² Watts Center Frequency - HZ							¹ Sound Rating Number (dB)
	125	250	500	1000	2000	4000	8000	
ELP090S4S	69	77	80	80	77	73	65	85
ELP120S4S	69	77	80	81	78	72	64	86

NOTE - the octave sound power data does not include tonal correction.

¹ Tested according to AHRI Standard 270 test conditions.

OPTIONS / ACCESSORIES

Item	Catalog No.	ELP090S4S	ELP120S4S
CABINET			
Combined Coil/Hail Guards	T2GARD51M11	13T30	X
	T2GARD51M21	13T32	X
Corrosion Protection	Factory	O	O
CONTROLS			
BACnet® Module		17A08	X
BACnet® Sensor with Display	K0SNSR01FF1	97W23	X
BACnet® Sensor without Display	K0SNSR00FF1	97W24	X
Low Ambient Control (0°F)	A2CWKT04M-1-	16F26	X
ELECTRICAL			
GFI Service Outlets	15 amp non-powered, field-wired (208/230V, 460V only) LTAGFIK10/15/15	74M70	X
	20 amp non-powered, field-wired (575V only) C1GFIC120FF1	67E01	X
INDOOR AIR QUALITY			
Sensor - Wall-mount, off-white plastic cover with LCD display	C0SNSR50AE1L	77N39	X
Sensor - Wall-mount, off-white plastic cover, no display	C0SNSR52AE1L	87N53	X
Sensor - Black plastic case with LCD display, rated for plenum mounting	C0SNSR51AE1L	87N52	X
Sensor - Wall-mount, black plastic case, no display, rated for plenum mounting	C0SNSR53AE1L	87N54	X
CO ₂ Sensor Duct Mounting Kit	C0MISC19AE1-	85L43	X
Aspiration Box - for duct mounting non-plenum rated CO ₂ sensor (77N39)	C0MISC16AE1-	90N43	X

NOTE - The catalog and model numbers that appear here are for ordering field installed accessories only.

O - Factory Installed with extended lead time.

X - Field Installed

AHRI SYSTEM MATCHES

Model	Cooling Btuh	EER	IEER	Heating Btuh		High Heat COP	Low Heat COP	Air Handler	AHRI Reference
				High	Low				
ELP090S4S	89,000	11.2	13.6	88,000	50,000	3.3	2.25	ELA090S4D	201753417
ELP120S4S	115,000	11.2	13.6	114,000	70,000	3.3	2.25	ELA120S4D	201753418

NOTES - Net capacity includes indoor blower motor heat deduction. Gross capacity does not include indoor blower motor heat deduction.

AHRI Certified to AHRI Standard 340/360:

Cooling Ratings - 95°F outdoor air temperature and 80°F db/67°F wb entering indoor coil air.

High Temperature Heating Ratings - 47°F db/43°F wb outdoor air temperature and 70°F db entering indoor coil air.

Low Temperature Heating Ratings - 17°F db/15°F wb outdoor air temperature and 70°F db entering indoor coil air.

WEIGHT DATA

Model No.	Net		Shipping	
	lbs.	kg	lbs.	kg
090S4S	425	193	450	204
120S4S	502	228	527	239

OPTIONS / ACCESSORIES

COMBINED COIL/HAIL GUARDS

T2GARD20M-1-	40	18	45	20
T2GARD21M-1-	45	20	50	23

UNIT CLEARANCES - INCHES (MM)

ELP090 AND ELP120

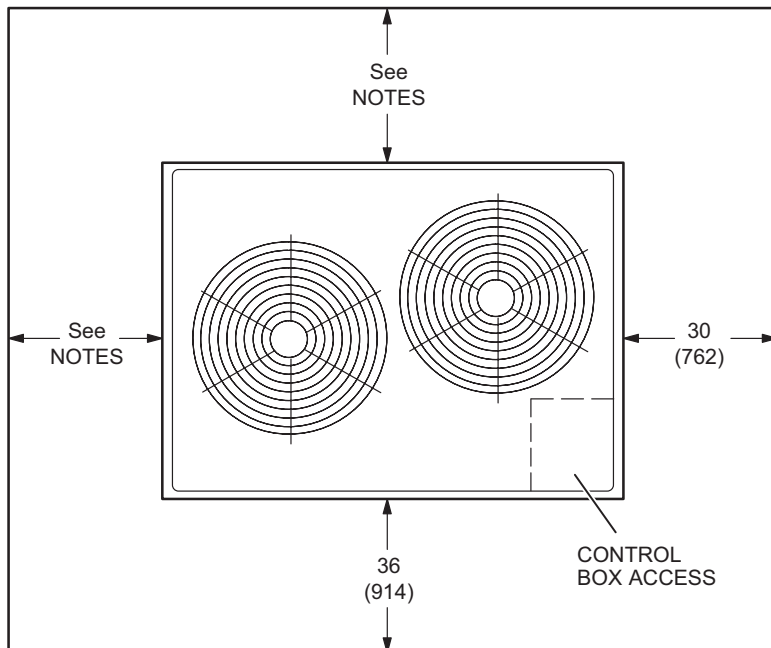

NOTES:

Clearance to one of the remaining two sides may be 12 in. (305 mm) and the final side may be 6 in. (152 mm).

A clearance of 24 in. (610 mm) must be maintained between two units.

48 in. (1219 mm) clearance required on top of unit.

DIMENSIONS - INCHES (MM)

Model No.	CORNER WEIGHTS								CENTER OF GRAVITY			
	AA		BB		CC		DD		EE		FF	
	lbs.	kg	lbs.	kg	lbs.	kg	lbs.	kg	in.	mm	in.	mm
ELP090S4S	108	49	108	49	114	52	114	52	21-3/4	552	29	737
ELP120S4S	120	54	114	52	139	63	149	68	20	508	25-1/4	641

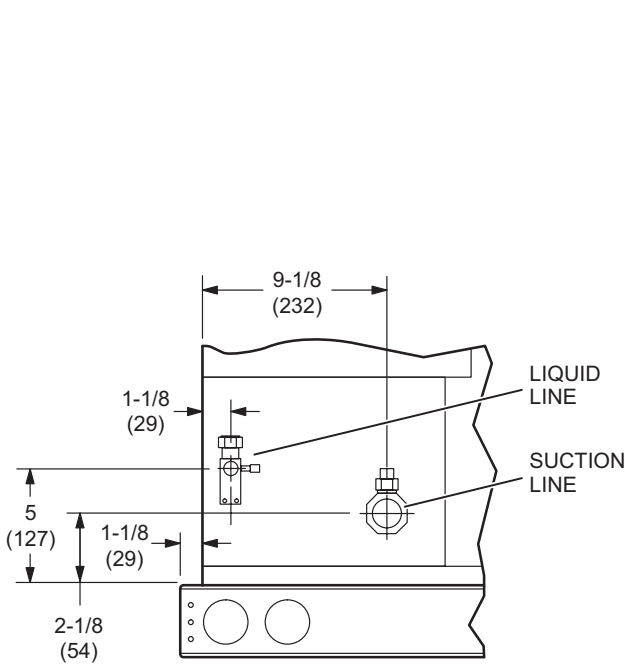

REFRIGERANT LINE CONNECTIONS DETAIL

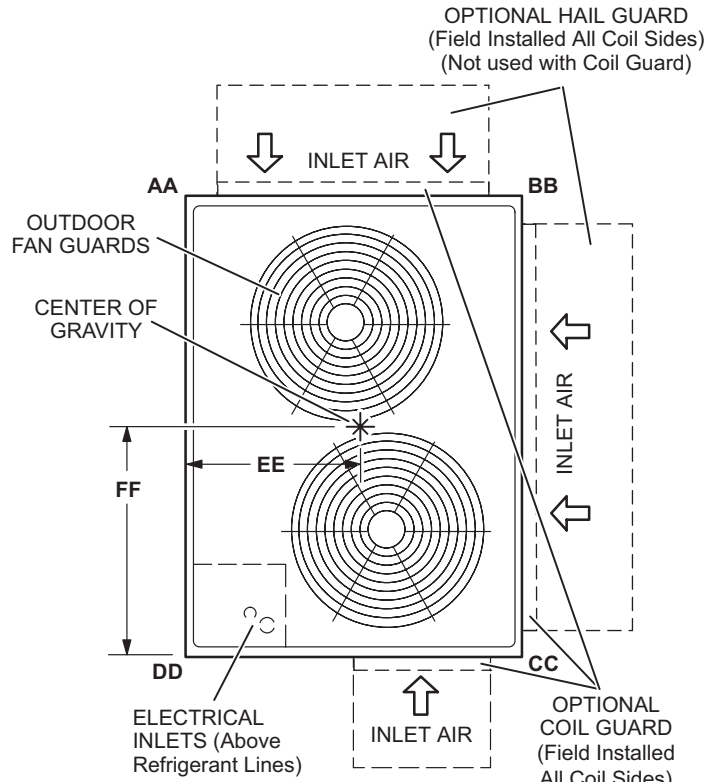

TOP VIEW

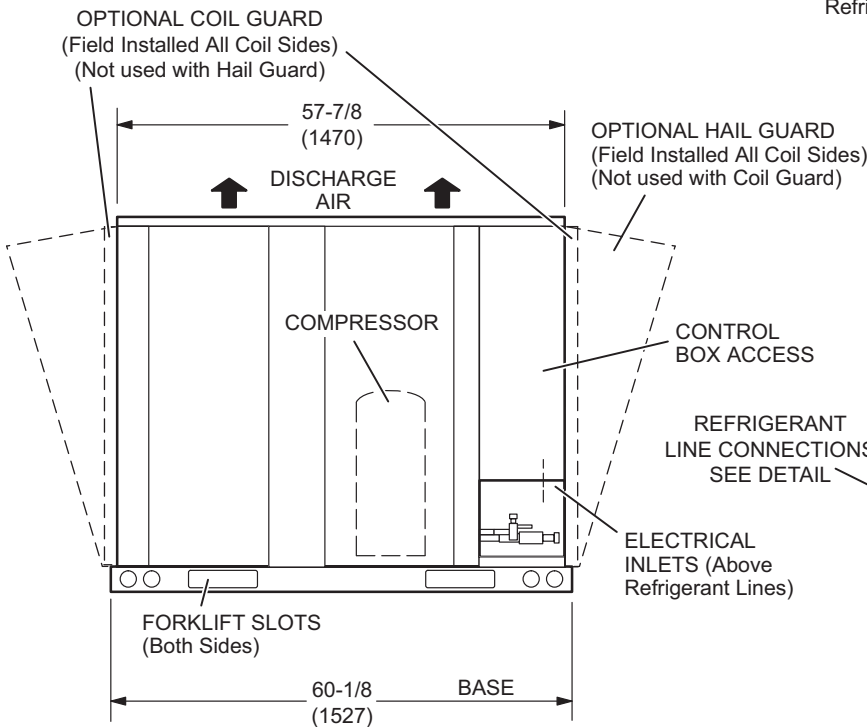

FRONT VIEW

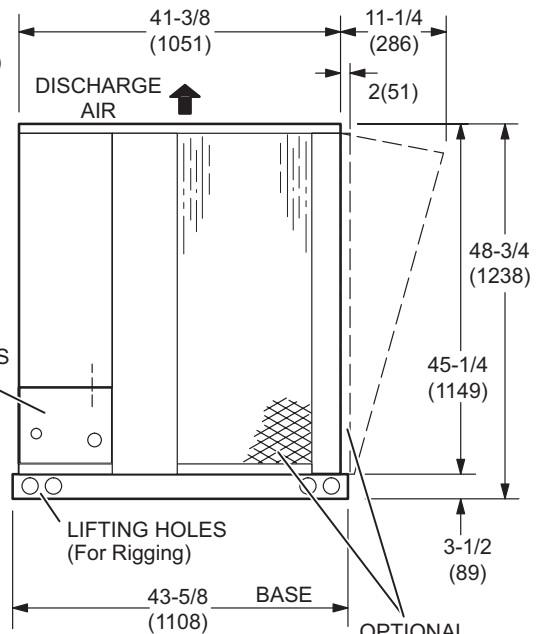

SIDE VIEW

OPTIONAL COIL GUARD (Field Installed All Coil Sides) (Not used with Hail Guard)

RATINGS

NOTE - For Temperatures and Capacities not shown in tables, see bulletin - Cooling Unit Rating Table Correction Factor Data in Miscellaneous Engineering Data section.

ELP090S4S + ELA090S4D - COOLING CAPACITY - PART LOAD

Entering Wet Bulb Temperature	Total Air Volume	Outdoor Air Temperature Entering Outdoor Coil																			
		65°F						75°F					85°F					95°F			
		Total Cool Cap.	Comp. Motor Input	Sensible To Total Ratio (S/T)			Total Cool Cap.	Comp. Motor Input	Sensible To Total Ratio (S/T)			Total Cool Cap.	Comp. Motor Input	Sensible To Total Ratio (S/T)			Total Cool Cap.	Comp. Motor Input	Sensible To Total Ratio (S/T)		
				Dry Bulb					Dry Bulb					Dry Bulb					Dry Bulb		
cfm	kBtuh	kW	75°F	80°F	85°F	kBtuh	kW	75°F	80°F	85°F	kBtuh	kW	75°F	80°F	85°F	kBtuh	kW	75°F	80°F	85°F	
63°F	1600	66.9	2.67	0.71	0.83	0.95	64.1	3.14	0.71	0.84	0.97	61.1	3.67	0.73	0.86	0.99	57.9	4.25	0.74	0.89	1
	2000	71	2.65	0.75	0.89	1	67.9	3.12	0.76	0.91	1	64.6	3.65	0.78	0.93	1	61.1	4.24	0.8	0.96	1
	2400	74	2.64	0.79	0.95	1	70.7	3.11	0.81	0.97	1	67.2	3.64	0.83	0.99	1	63.8	4.22	0.85	1	1
67°F	1600	71.5	2.65	0.56	0.68	0.79	68.7	3.12	0.57	0.69	0.81	65.6	3.65	0.58	0.7	0.82	62.1	4.23	0.58	0.72	0.85
	2000	75.7	2.63	0.59	0.73	0.85	72.5	3.1	0.59	0.73	0.87	69.2	3.63	0.61	0.75	0.9	65.5	4.22	0.62	0.77	0.92
71°F	2400	78.9	2.62	0.62	0.77	0.91	75.3	3.09	0.63	0.78	0.93	71.5	3.62	0.63	0.8	0.96	67.6	4.21	0.65	0.83	0.98
	1600	76.3	2.63	0.44	0.55	0.65	73.2	3.1	0.44	0.55	0.66	69.9	3.63	0.44	0.56	0.68	66.5	4.21	0.44	0.57	0.69
	2000	80.7	2.61	0.45	0.57	0.69	77.3	3.08	0.45	0.58	0.71	73.8	3.61	0.46	0.59	0.73	69.9	4.2	0.46	0.6	0.74
	2400	84	2.6	0.46	0.6	0.74	80.3	3.07	0.46	0.61	0.76	76.3	3.6	0.47	0.61	0.78	72.1	4.19	0.47	0.64	0.8

ELP090S4S + ELA090S4D - COOLING CAPACITY - FULL LOAD

Entering Wet Bulb Temperature	Total Air Volume	Outdoor Air Temperature Entering Outdoor Coil																			
		85°F					95°F					105°F					115°F				
		Total Cool Cap.	Comp. Motor Input	Sensible To Total Ratio (S/T)			Total Cool Cap.	Comp. Motor Input	Sensible To Total Ratio (S/T)			Total Cool Cap.	Comp. Motor Input	Sensible To Total Ratio (S/T)			Total Cool Cap.	Comp. Motor Input	Sensible To Total Ratio (S/T)		
				Dry Bulb					Dry Bulb					Dry Bulb					Dry Bulb		
cfm	kBtuh	kW	75°F	80°F	85°F	kBtuh	kW	75°F	80°F	85°F	kBtuh	kW	75°F	80°F	85°F	kBtuh	kW	75°F	80°F	85°F	
63°F	2400	87.7	5.85	0.72	0.86	0.98	83.3	6.47	0.74	0.88	1	78.8	7.16	0.75	0.9	1	74	7.93	0.78	0.93	1
	3000	92.1	5.94	0.78	0.93	1	87.8	6.57	0.79	0.95	1	82.7	7.26	0.82	0.98	1	77.8	8.03	0.84	1	1
	3600	95.7	6.01	0.82	0.98	1	91.1	6.64	0.85	1	1	86.5	7.35	0.87	1	1	81.9	8.13	0.9	1	1
67°F	2400	93.3	5.97	0.58	0.7	0.82	88.8	6.59	0.58	0.71	0.84	84.2	7.29	0.59	0.73	0.87	78.9	8.06	0.6	0.75	0.9
	3000	97.8	6.06	0.6	0.75	0.89	93	6.69	0.61	0.76	0.91	88.2	7.39	0.62	0.79	0.94	82.4	8.15	0.64	0.82	0.98
	3600	101.1	6.13	0.63	0.8	0.95	96.1	6.76	0.65	0.82	0.98	90.7	7.45	0.66	0.84	1	84.9	8.21	0.68	0.88	1
71°F	2400	99.2	6.09	0.44	0.56	0.68	94.5	6.72	0.44	0.57	0.69	89.5	7.42	0.45	0.57	0.7	84.2	8.19	0.45	0.59	0.73
	3000	103.7	6.18	0.45	0.59	0.72	98.8	6.82	0.46	0.6	0.74	93.4	7.51	0.46	0.61	0.76	87.7	8.28	0.46	0.63	0.79
	3600	107.1	6.25	0.46	0.62	0.77	101.9	6.88	0.47	0.64	0.8	96.4	7.58	0.48	0.65	0.82	90.1	8.34	0.49	0.67	0.85

ELP090S4S + ELA090S4D - HEATING CAPACITY

Indoor Coil Air Volume 70°F Dry Bulb cfm	Air Temperature Entering Outdoor Coil									
	65°F		45°F		25°F		5°F		-15°F	
	Total Heating Capacity	Comp. Motor Input	Total Heating Capacity	Comp. Motor Input	Total Heating Capacity	Comp. Motor Input	Total Heating Capacity	Comp. Motor Input	Total Heating Capacity	Comp. Motor Input
	kBtuh	kW	kBtuh	kW	kBtuh	kW	kBtuh	kW	kBtuh	kW
2400	110.2	6.88	84.8	6.34	59.3	5.8	35.7	5.07	17.8	3.81
3000	112.2	6.51	86.7	5.97	61.3	5.43	37.6	4.7	19.8	3.44
3600	113.5	6.28	88.1	5.73	62.6	5.19	39	4.46	21.1	3.2

ELP090S4S + ELA090S4D

HEATING PERFORMANCE at 3000 cfm Indoor Coil Air Volume

Temperature °F	Motor Input kW	Output kBtuh
65	6.51	112.2
60	6.38	105.8
55	6.24	99.4
50	6.1	93.1
47	6.02	89.3
45	5.97	86.7
40	5.84	80.4
35	5.7	74.1
30	5.56	67.7
25	5.43	61.3
20	5.29	54.9
17	5.2	51
15	5.15	48.5
10	5.01	42.1
5	4.7	37.6
0	4.38	33.2
-5	4.07	28.7
-10	3.75	24.2
-15	3.44	19.8
-20	3.12	15.3

RATINGS

NOTE - For Temperatures and Capacities not shown in tables, see bulletin - Cooling Unit Rating Table Correction Factor Data in Miscellaneous Engineering Data section.

ELP120S4S + ELA120S4D - COOLING CAPACITY - PART LOAD

Entering Wet Bulb Temperature	Total Air Volume	Outdoor Air Temperature Entering Outdoor Coil																							
		65°F						75°F						85°F						95°F					
		Total Cool Cap.	Comp. Motor Input	Sensible To Total Ratio (S/T)			Total Cool Cap.	Comp. Motor Input	Sensible To Total Ratio (S/T)			Total Cool Cap.	Comp. Motor Input	Sensible To Total Ratio (S/T)			Total Cool Cap.	Comp. Motor Input	Sensible To Total Ratio (S/T)						
				Dry Bulb					Dry Bulb					Dry Bulb					Dry Bulb						
cfm	kBtuh	kW	75°F	80°F	85°F	kBtuh	kW	75°F	80°F	85°F	kBtuh	kW	75°F	80°F	85°F	kBtuh	kW	75°F	80°F	85°F					
63°F	2240	88.4	3.27	0.72	0.85	0.97	84.3	3.87	0.73	0.87	0.99	79.1	4.58	0.75	0.9	1	73.1	5.36	0.78	0.93	1				
	2800	92.9	3.23	0.77	0.92	1	88.9	3.83	0.79	0.94	1	83.7	4.53	0.81	0.97	1	77.4	5.3	0.84	1	1				
	3360	96.1	3.2	0.82	0.98	1	92.3	3.79	0.84	1	1	87.7	4.48	0.86	1	1	82.3	5.25	0.9	1	1				
67°F	2240	93.9	3.21	0.57	0.69	0.82	90.4	3.82	0.58	0.71	0.83	85.2	4.51	0.59	0.72	0.86	79.1	5.29	0.6	0.75	0.89				
	2800	98.6	3.18	0.6	0.74	0.89	94.9	3.77	0.61	0.76	0.9	89.7	4.46	0.62	0.78	0.93	83.3	5.25	0.64	0.81	0.97				
	3360	101.5	3.15	0.63	0.8	0.95	98.3	3.75	0.64	0.81	0.97	92.8	4.43	0.65	0.83	0.99	86.3	5.22	0.67	0.87	1				
71°F	2240	99.4	3.17	0.44	0.55	0.67	96.1	3.76	0.44	0.56	0.68	91.2	4.45	0.44	0.57	0.7	85.2	5.22	0.45	0.58	0.72				
	2800	104	3.14	0.44	0.58	0.72	100.8	3.72	0.45	0.6	0.73	96.1	4.4	0.46	0.61	0.75	89.8	5.19	0.47	0.63	0.78				
	3360	107.1	3.12	0.46	0.62	0.78	104.3	3.7	0.46	0.63	0.79	99.2	4.37	0.47	0.64	0.81	92.9	5.15	0.48	0.66	0.84				

ELP120S4S + ELA120S4D - COOLING CAPACITY - FULL LOAD

Entering Wet Bulb Temperature	Total Air Volume	Outdoor Air Temperature Entering Outdoor Coil																							
		85°F						95°F						105°F						115°F					
		Total Cool Cap.	Comp. Motor Input	Sensible To Total Ratio (S/T)			Total Cool Cap.	Comp. Motor Input	Sensible To Total Ratio (S/T)			Total Cool Cap.	Comp. Motor Input	Sensible To Total Ratio (S/T)			Total Cool Cap.	Comp. Motor Input	Sensible To Total Ratio (S/T)						
				Dry Bulb					Dry Bulb					Dry Bulb					Dry Bulb						
cfm	kBtuh	kW	75°F	80°F	85°F	kBtuh	kW	75°F	80°F	85°F	kBtuh	kW	75°F	80°F	85°F	kBtuh	kW	75°F	80°F	85°F					
63°F	3200	112.4	7.1	0.74	0.89	1	106.4	7.92	0.76	0.91	1	99.5	8.87	0.78	0.94	1	91.9	9.93	0.81	0.98	1				
	4000	117.8	7.15	0.8	0.96	1	111.8	7.98	0.82	0.98	1	104.7	8.92	0.85	1	1	98.1	10.01	0.89	1	1				
	4800	122.7	7.2	0.85	1	1	117.2	8.03	0.88	1	1	110.7	9	0.91	1	1	103.4	10.06	0.95	1	1				
67°F	3200	120.1	7.18	0.58	0.72	0.85	114	8	0.59	0.73	0.87	106.7	8.94	0.61	0.76	0.9	98.6	10.01	0.62	0.79	0.94				
	4000	125.7	7.24	0.62	0.77	0.93	119.3	8.06	0.63	0.79	0.95	111.6	9	0.64	0.82	0.98	103	10.06	0.67	0.86	1				
	4800	129.9	7.28	0.65	0.83	0.99	123.1	8.11	0.66	0.85	1	115.2	9.04	0.68	0.88	1	105.9	10.09	0.71	0.93	1				
71°F	3200	127.7	7.25	0.44	0.57	0.69	121.4	8.08	0.44	0.58	0.71	114.1	9.03	0.45	0.59	0.73	105.7	10.09	0.46	0.61	0.76				
	4000	133.9	7.33	0.45	0.6	0.75	127.1	8.15	0.46	0.61	0.77	119.3	9.09	0.47	0.63	0.79	110.4	10.15	0.47	0.65	0.83				
	4800	138.2	7.37	0.47	0.64	0.8	131.3	8.2	0.47	0.65	0.83	122.8	9.13	0.48	0.67	0.86	113.7	10.2	0.49	0.7	0.9				

ELP120S4S + ELA120S4D - HEATING CAPACITY

Indoor Coil Air Volume 70°F Dry Bulb cfm	Air Temperature Entering Outdoor Coil									
	65°F		45°F		25°F		5°F		-15°F	
	Total Heating Capacity	Comp. Motor Input	Total Heating Capacity	Comp. Motor Input	Total Heating Capacity	Comp. Motor Input	Total Heating Capacity	Comp. Motor Input	Total Heating Capacity	Comp. Motor Input
	kBtuh	kW	kBtuh	kW	kBtuh	kW	kBtuh	kW	kBtuh	kW
3200	138.4	8	109.1	7.35	79.9	6.71	51.3	5.87	25.1	4.41
4000	141.1	7.56	111.8	6.92	82.6	6.27	54	5.43	27.8	3.98
4800	142.9	7.28	113.6	6.64	84.3	6	55.8	5.16	29.6	3.7

ELP120S4S + ELA120S4D HEATING PERFORMANCE at 4000 cfm Indoor Coil Air Volume

Temperature °F	Motor Input kW	Output kBtuh
65	7.56	141.1
60	7.4	133.8
55	7.24	126.5
50	7.08	119.1
47	6.98	114.8
45	6.92	111.8
40	6.75	104.5
35	6.59	97.2
30	6.43	89.9
25	6.27	82.6
20	6.11	75.2
17	6.02	70.8
15	5.96	67.9
10	5.8	60.5
5	5.43	54
0	5.07	47.4
-5	4.7	40.9
-10	4.34	34.3
-15	3.98	27.8
-20	3.61	21.2

REVISIONS

Sections	Description of Change
Ratings tables	Updated existing tables.



Visit us at www.allied-commercial.com

For the latest technical information, visit us at www.allied-commercial.com

Contact us at 1-800-738-4000

NOTE - Due to Allied Commercial ongoing commitment to quality, Specifications, Ratings and Dimensions subject to change without notice and without incurring liability. Improper installation, adjustment, alteration, service or maintenance can cause property damage or personal injury. Installation and service must be performed by a qualified installer and servicing agency.