



INSTALLATION INSTRUCTIONS

T-Series™ - ELS 6 – 20 Ton

AIR CONDITIONERS
6 - 20 TONS
507822-01
3/2018

**THIS MANUAL MUST BE LEFT WITH THE
BUILDING OWNER FOR FUTURE REFERENCE**

⚠ WARNING

Improper installation, adjustment, alteration, service or maintenance can cause property damage, personal injury or loss of life. Installation and service must be performed by a licensed professional HVAC installer or equivalent, or service agency.

⚠ IMPORTANT

The Clean Air Act of 1990 bans the intentional venting of refrigerant (CFCs, HCFCs and HFCs) as of July 1, 1992. Approved methods of recovery, recycling or reclaiming must be followed. Fines and/or incarceration may be levied for noncompliance.

⚠ CAUTION

As with any mechanical equipment, contact with sharp sheet metal edges can result in personal injury. Take care while handling this equipment and wear gloves and protective clothing.

Table of Contents

Shipping and Packing List	1
Outdoor Unit	1
Unit Dimensions, Corner Weights and Centers of Gravity ...	2
Unit Plumbing Parts Arrangement	5
Model Number Identification	10
Unit Control Box Components Arrangement	11
Rigging the Unit for Lifting	12
Installation Clearances	13
Line Set	13
Electrical Connections	13
Refrigerant Charge	19
System Operation	21
Maintenance	21

Shipping and Packing List

Check the unit for shipping damage. If damaged or parts are missing, immediately contact the last shipping carrier.

- 1 - Assembled outdoor unit
- 1 - Installation instructions

Outdoor Unit

ELS Series Air Conditioners, which will also be referred to in this instruction as the outdoor unit, use HFC-410A refrigerant. This outdoor unit must be installed with a matching indoor unit and line set as outlined in the ELS Series Engineering Handbook.

This outdoor unit is designed for use in thermal expansion valve (TXV) systems only.



Unit Dimensions, Corner Weights and Centers of Gravity

ELS072S4S AND ELS090S4S

Corner Weights

Model No.	AA		BB		CC		DD	
	lbs.	kg	lbs.	kg	lbs.	kg	lbs.	kg
ELS072S4S	66	30	73	33	97	44	82	37
ELS090S4S	75	34	89	40	112	51	88	40

Centers of Gravity

Model No.	EE		FF	
	inch	mm	inch	mm
ELS072S4S	23.2	589.3	19.2	487.7
ELS090S4S	25	635	20.3	515.6

INCHES (MM)

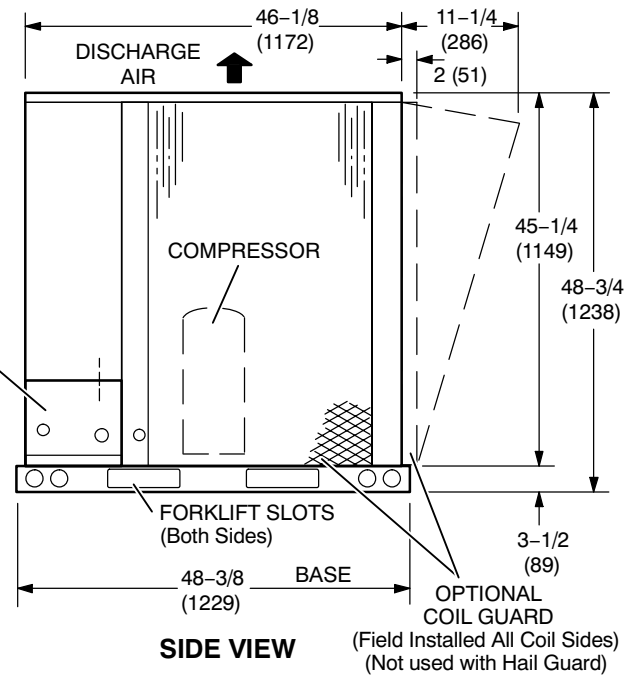
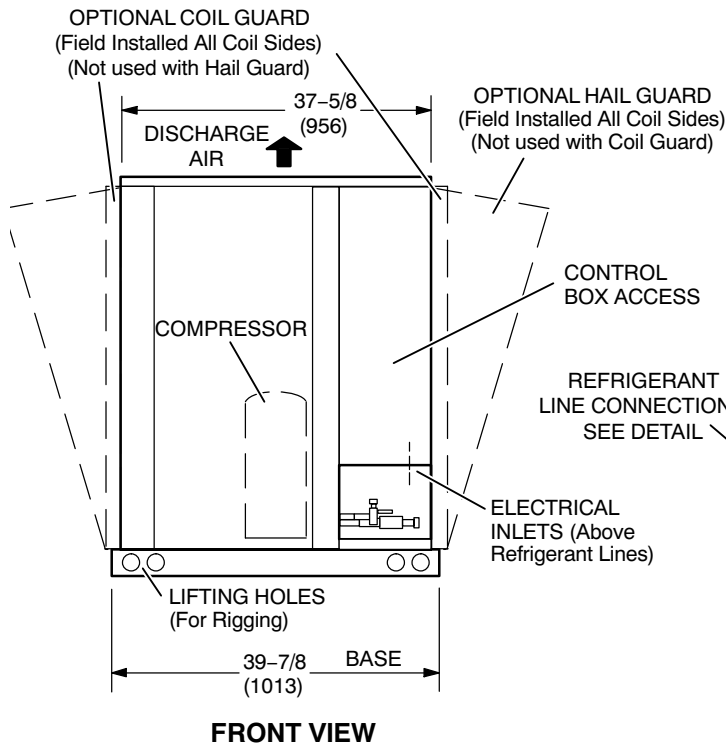
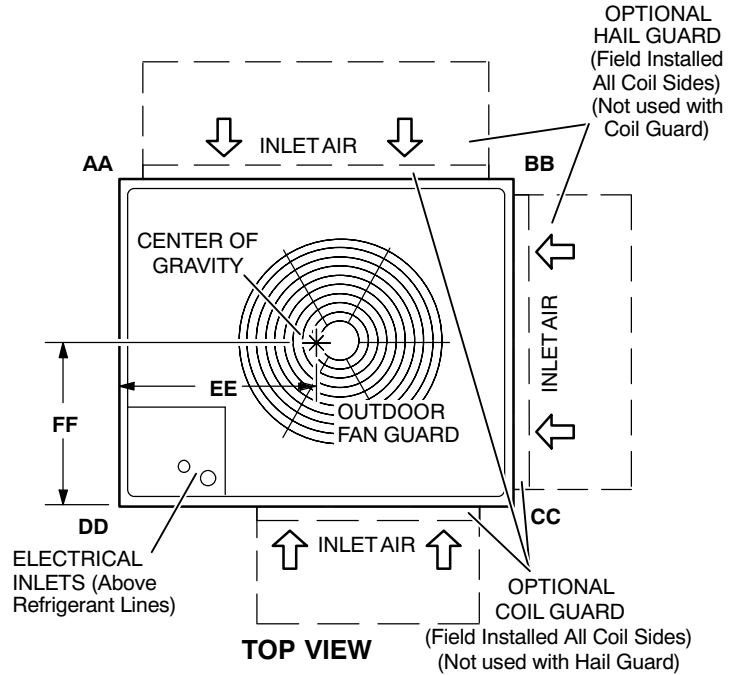
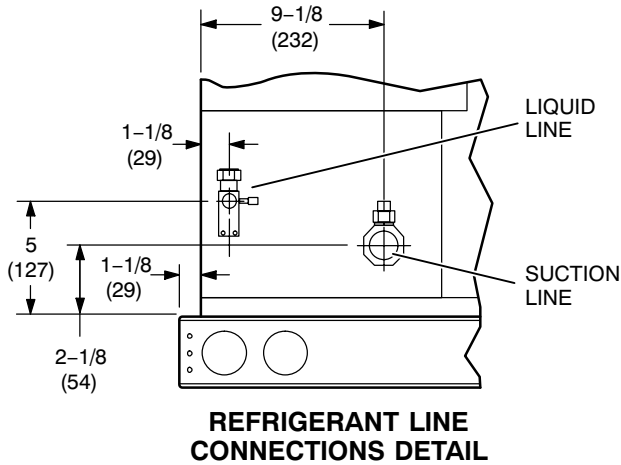

ELS120S4S, ELS120S4D AND ELS150S4D

Corner Weight

Model No.	AA		BB		CC		DD	
	lbs.	kg	lbs.	kg	lbs.	kg	lbs.	kg
ELS 120S4S	130	59	124	56	107	49	111	50
ELS 120S4D	122	55	119	54	127	58	131	59
ELS 150S4D	144	66	132	60	133	60	145	66

Centers of Gravity

Model No.	EE		FF	
	inch	mm	inch	mm
ELS 120S4S	20.5	521	33.5	851
ELS 120S4D	21.0	533	28.5	724
ELS 150S4D	19.0	483	30.0	762

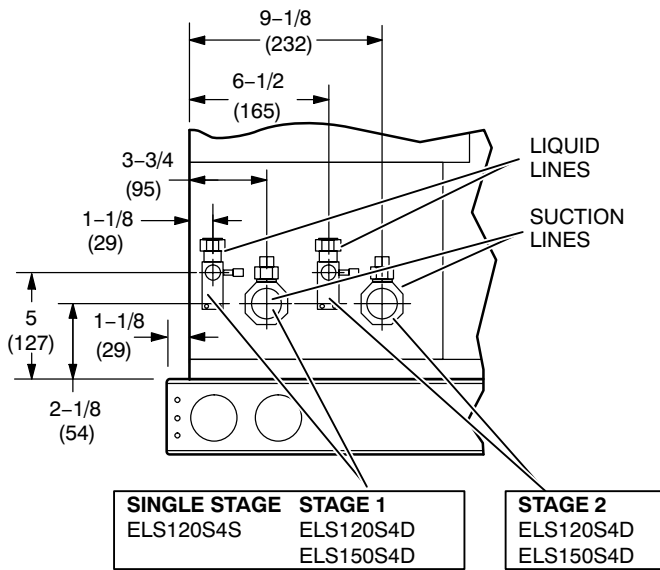

REFRIGERANT LINE CONNECTIONS DETAIL

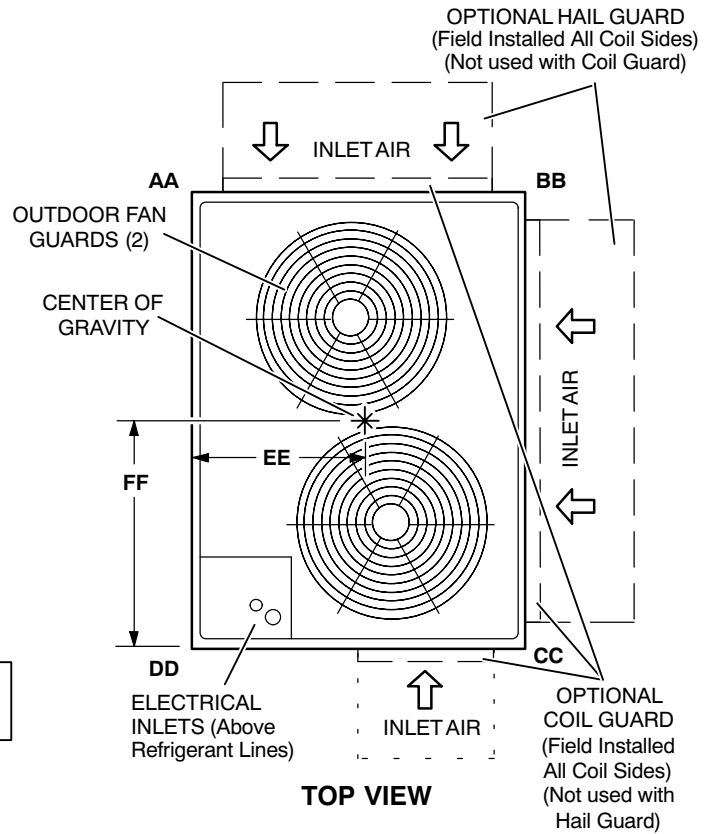

TOP VIEW

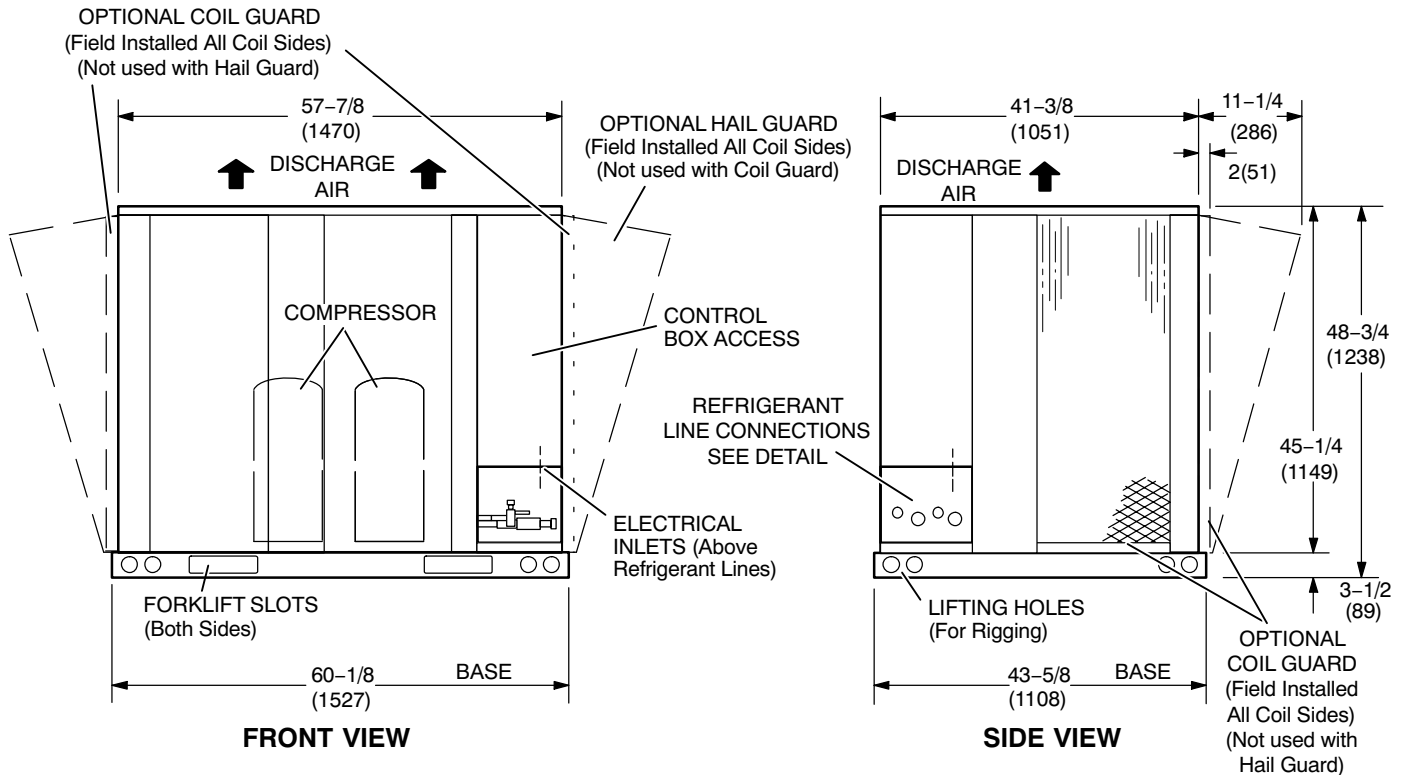

FRONT VIEW

SIDE VIEW

ELS180S4D AND ELS240S4D

Corner Weight

Model No.	AA		BB		CC		DD	
	lbs.	kg	lbs.	kg	lbs.	kg	lbs.	kg
ELS180S4D	181	82	177	81	215	98	221	100
ELS240S4D	192	87	189	86	232	105	238	108

Centers of Gravity

Model No.	EE		FF	
	inch	mm	inch	mm
ELS180S4D	29	737	38	965
ELS240S4D	29	739	38	965

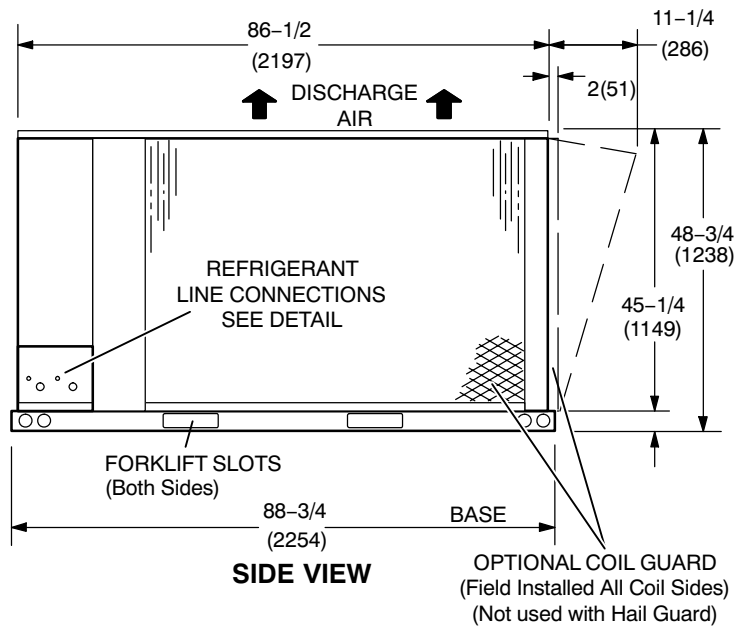
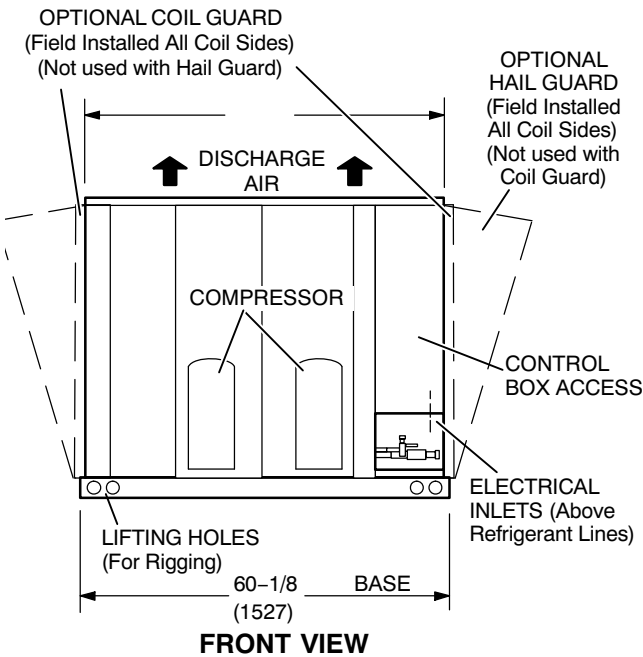
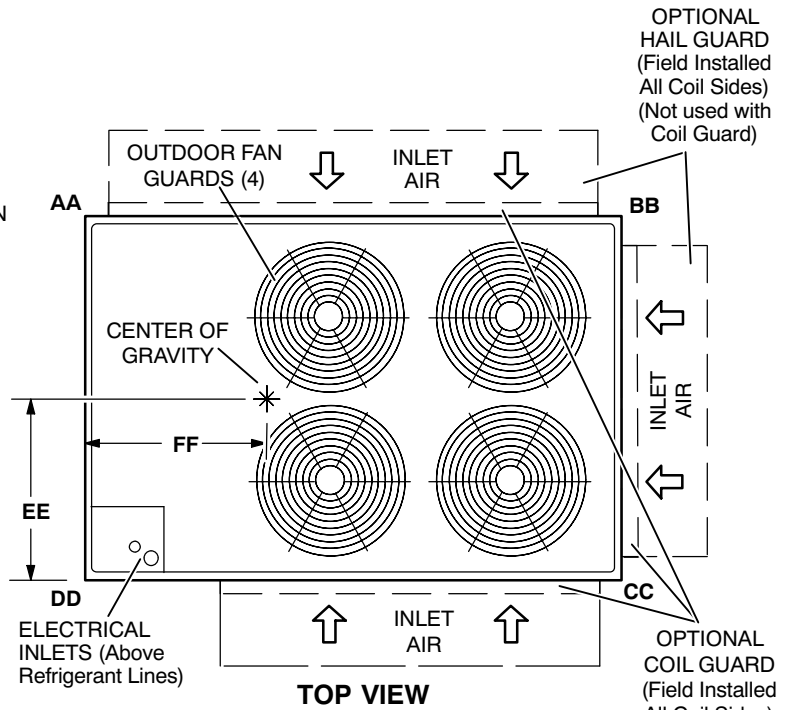
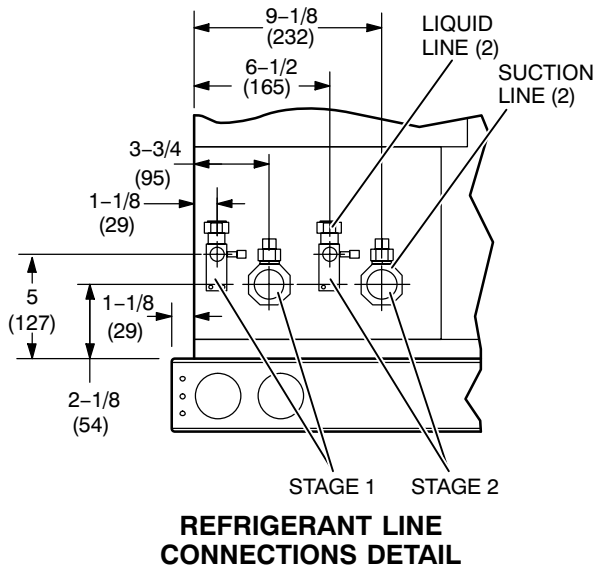

Unit Plumbing Parts Arrangement

ELS072S4S

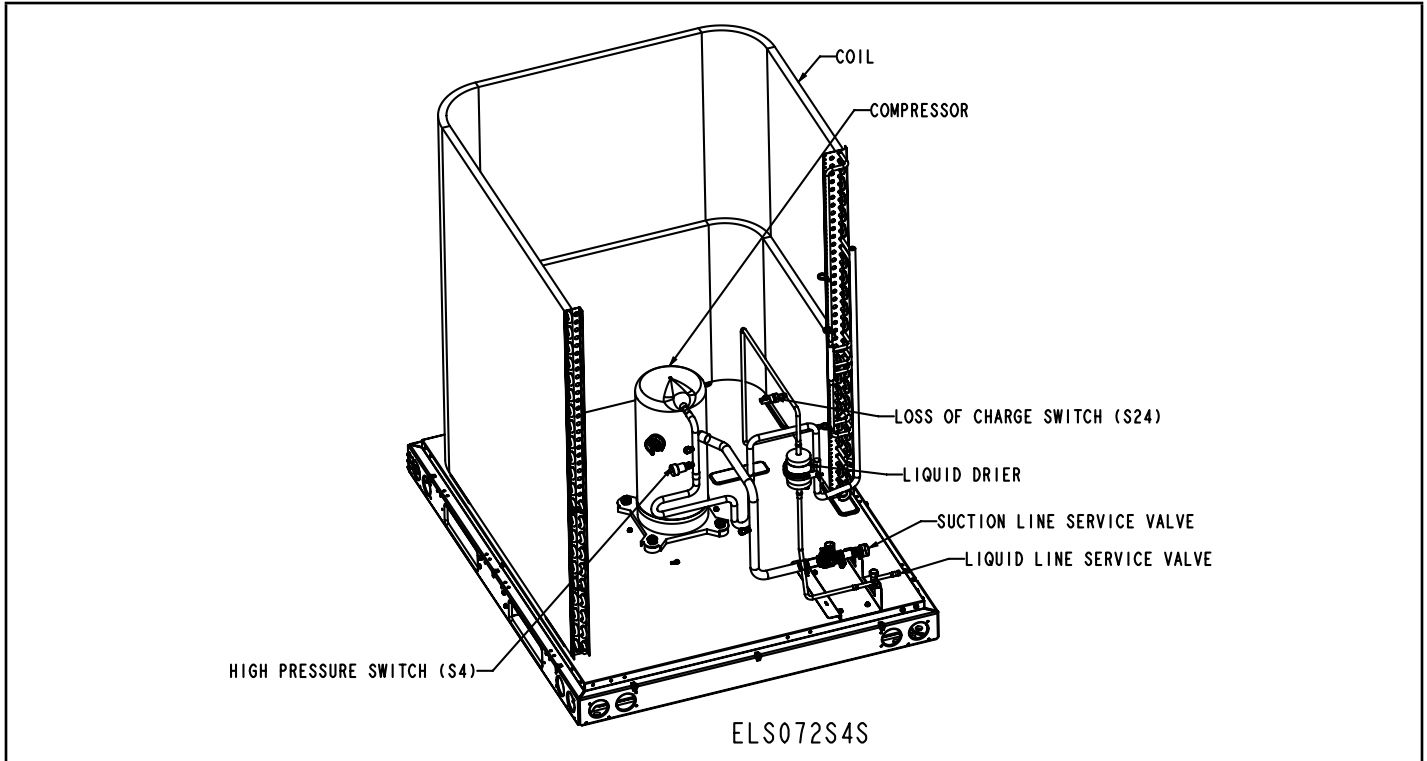

ELS090S4S

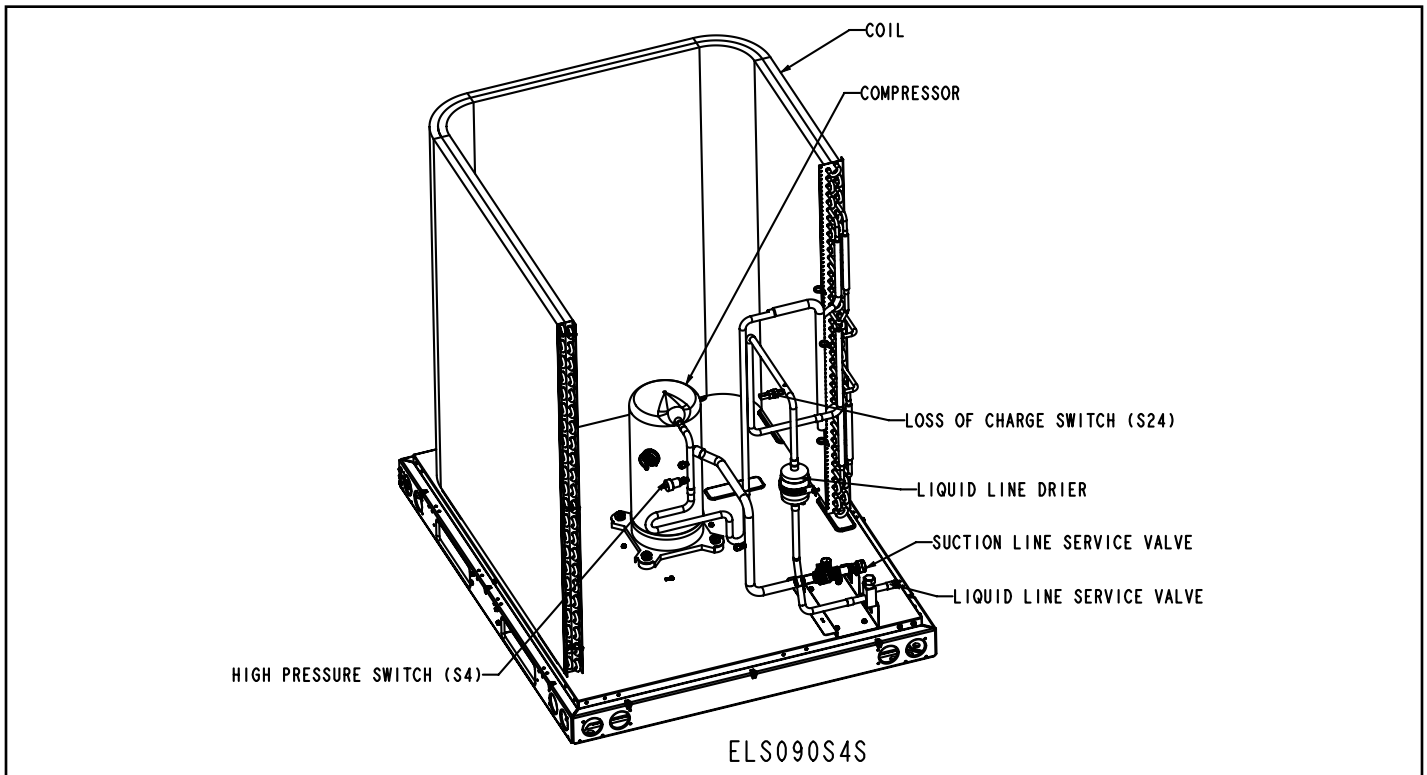

ELS120S4S

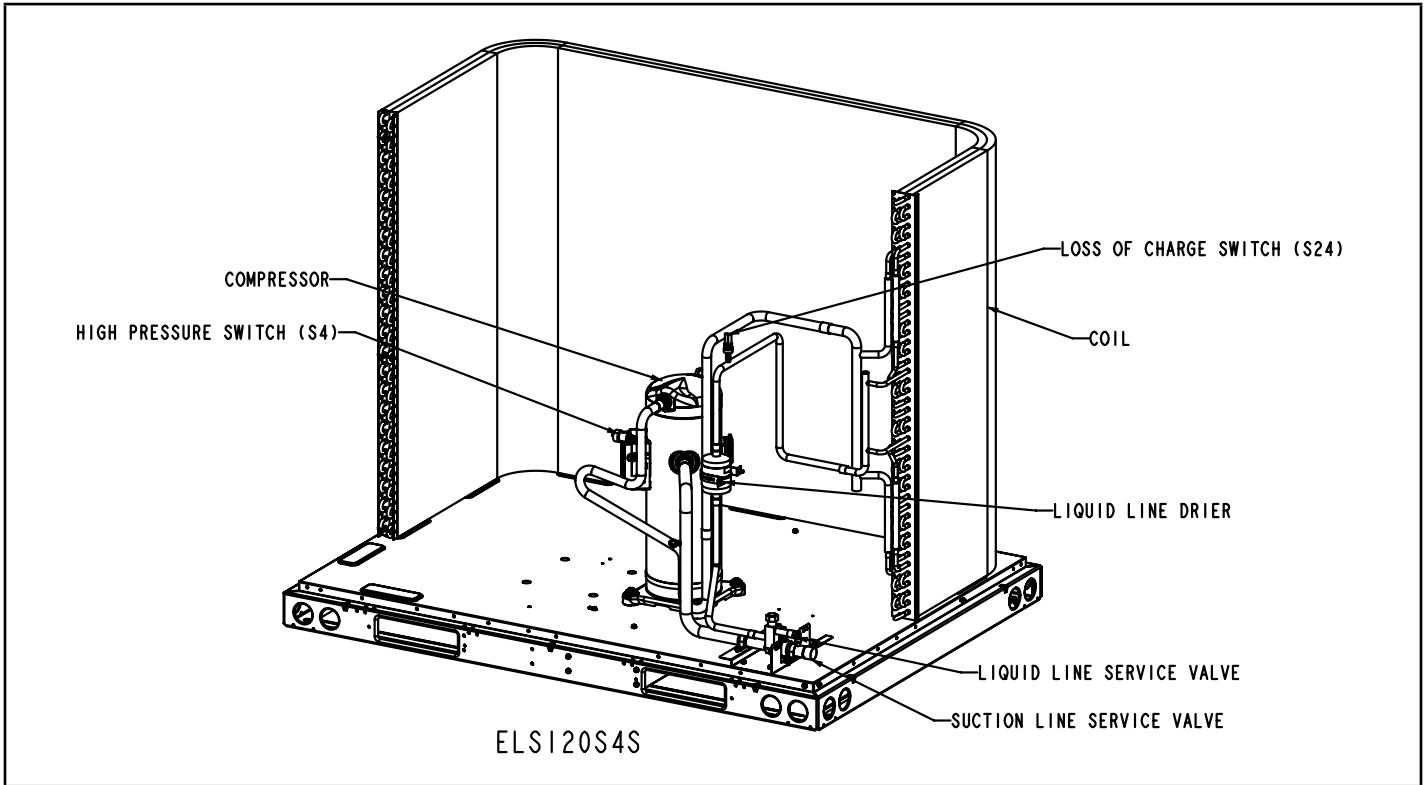

ELS120S4D – STAGE 2

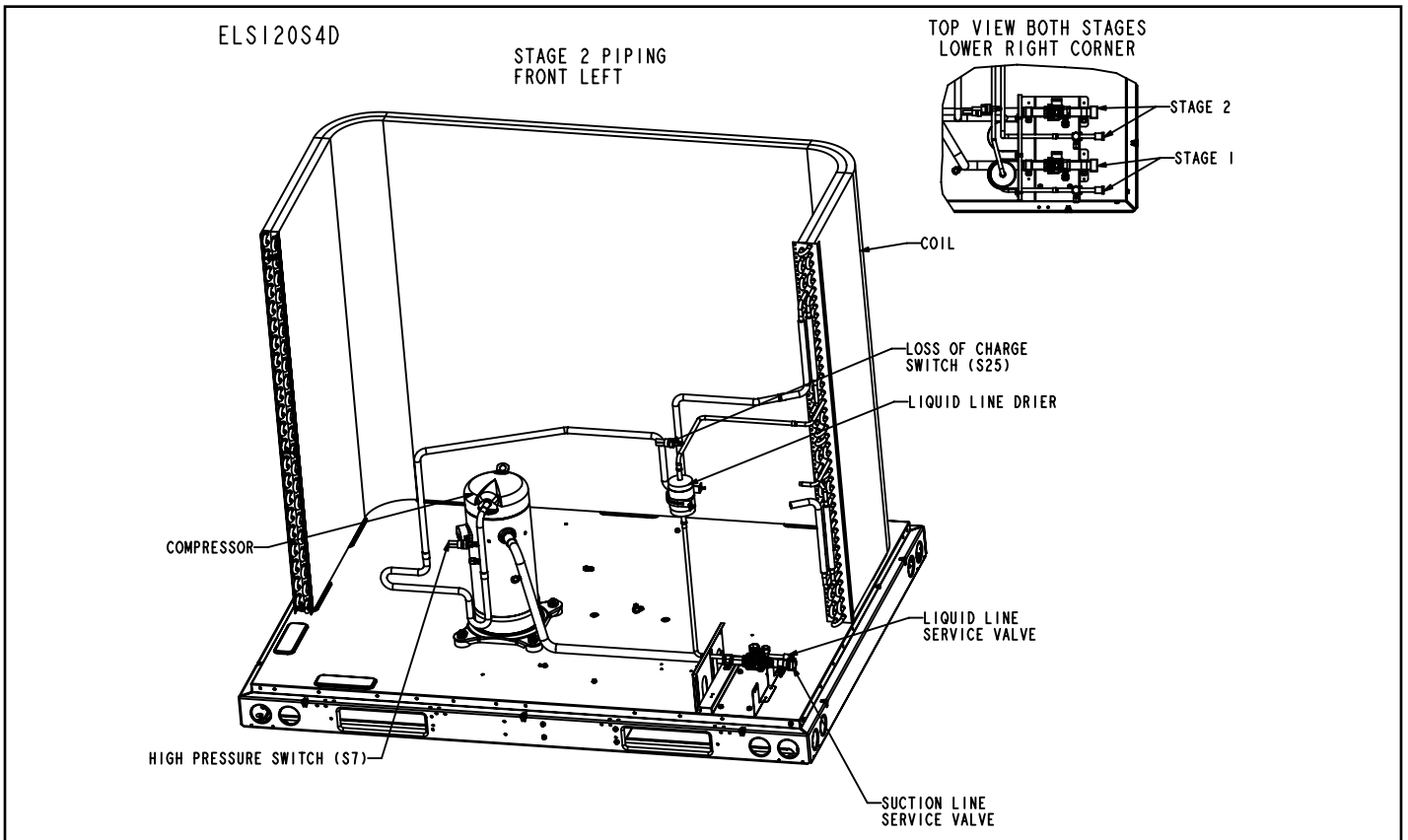

ELS120S4D – STAGE 1

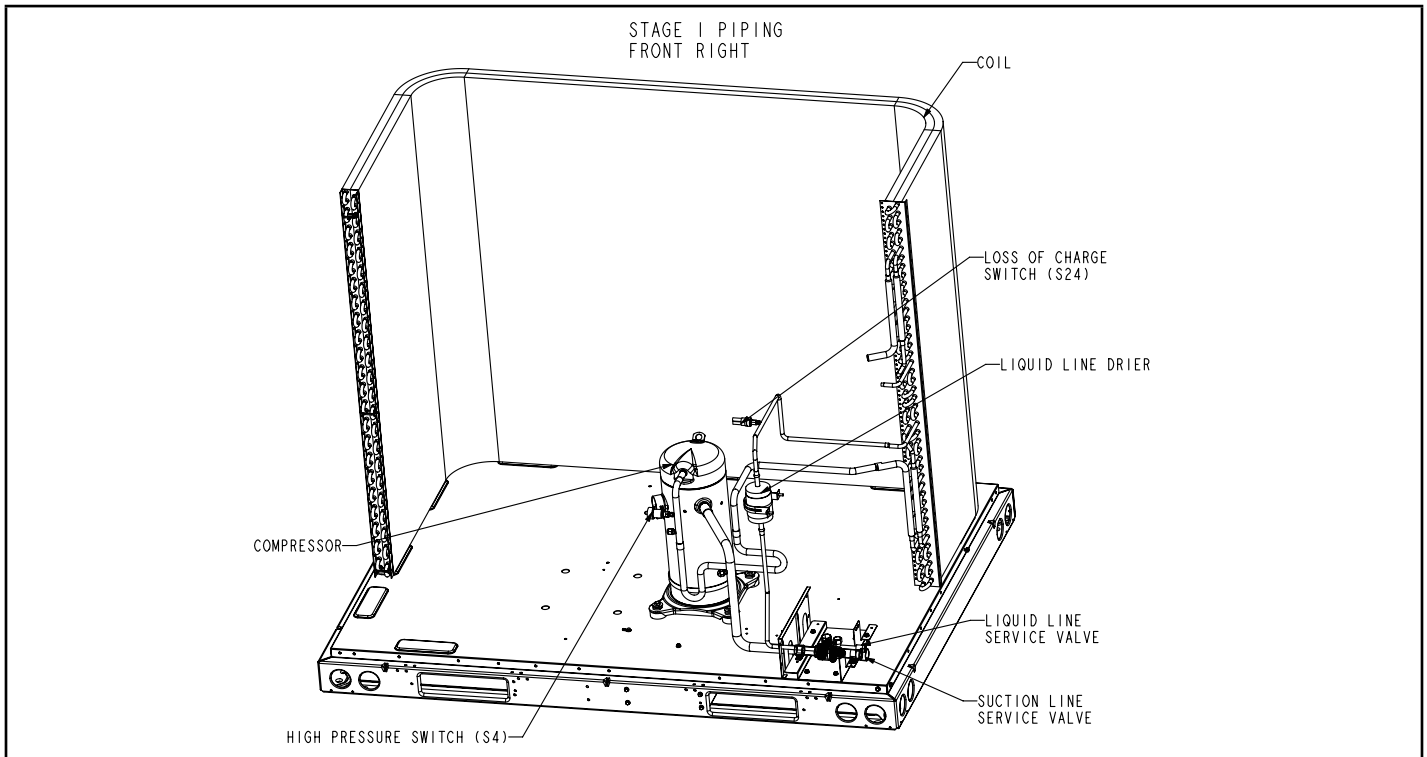

ELS150S4D – STAGE 2

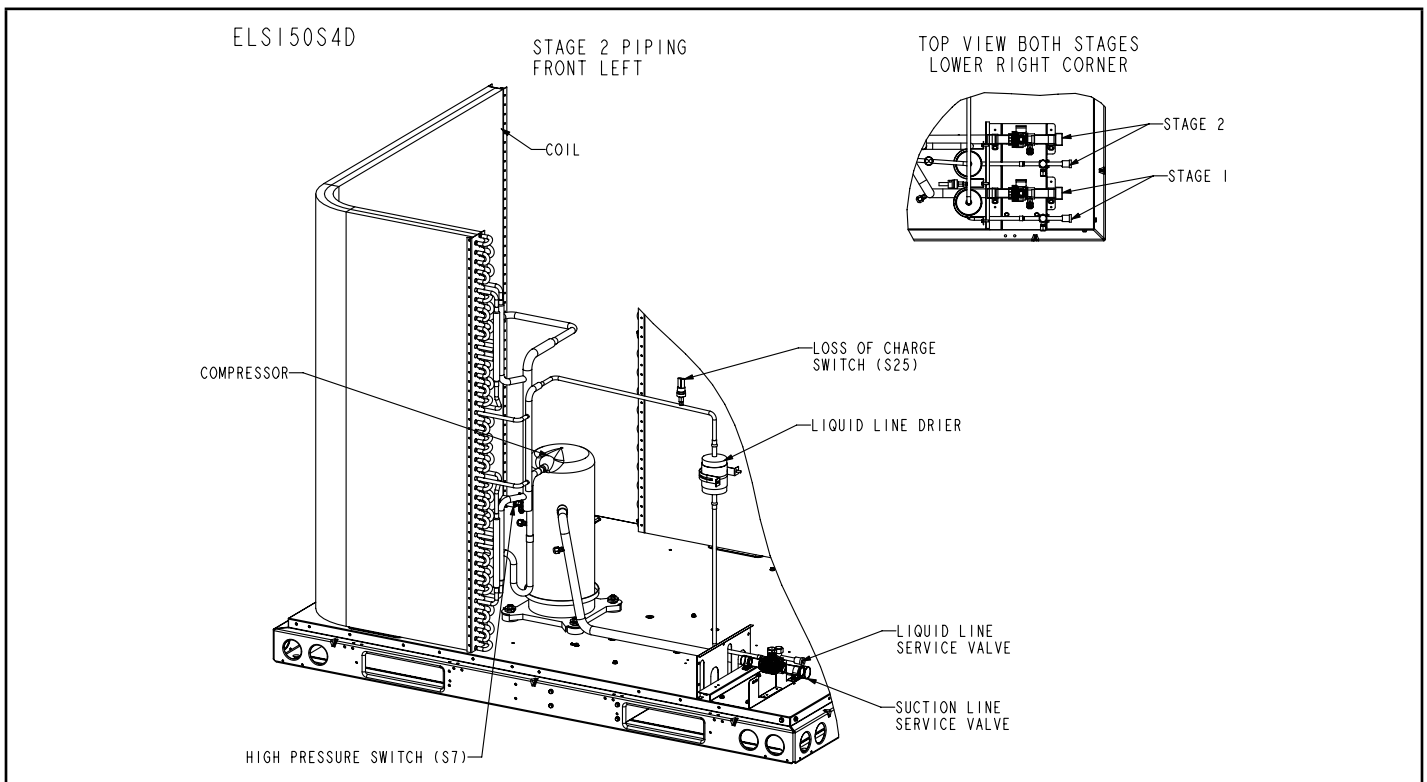

ELS150S4D – STAGE 1

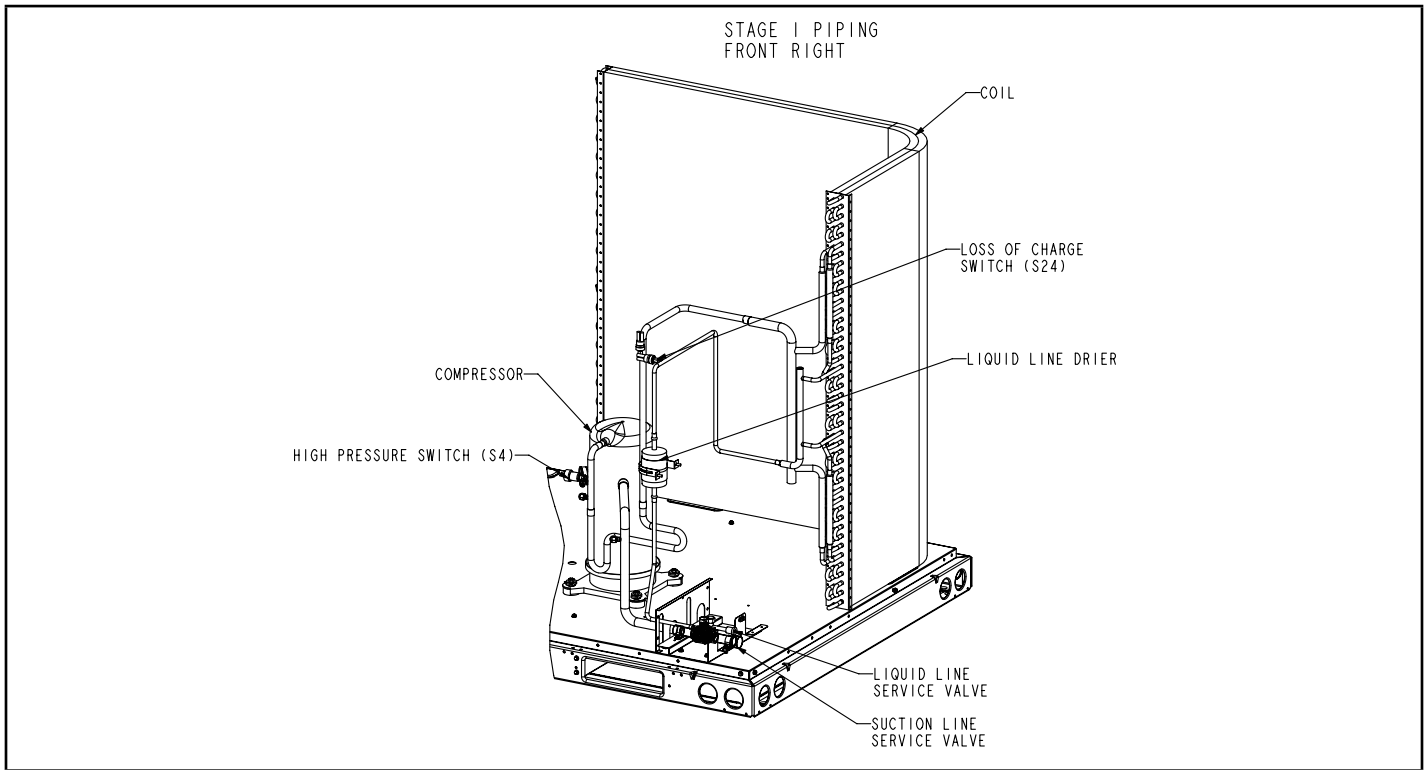

ELS180S4D – STAGE 2

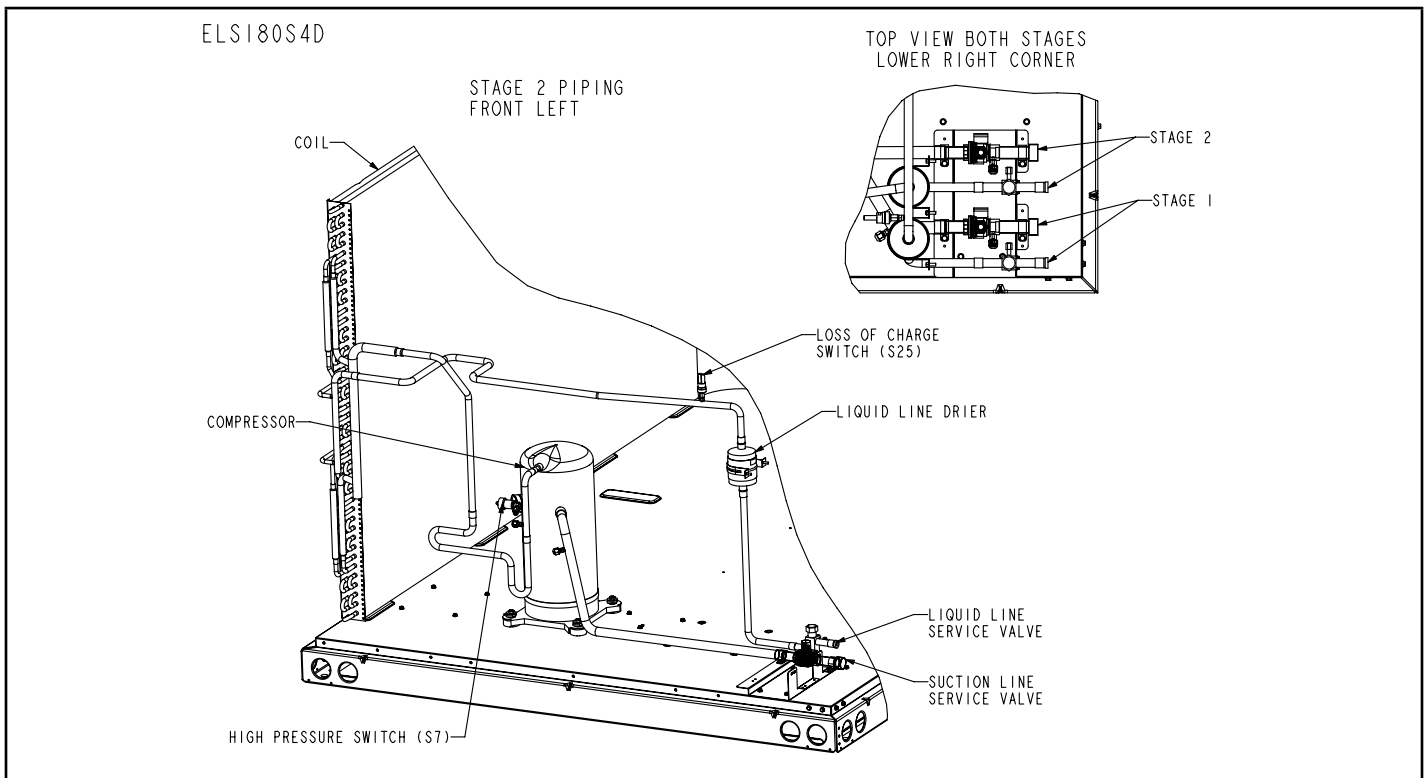

ELS180S4D – STAGE 1

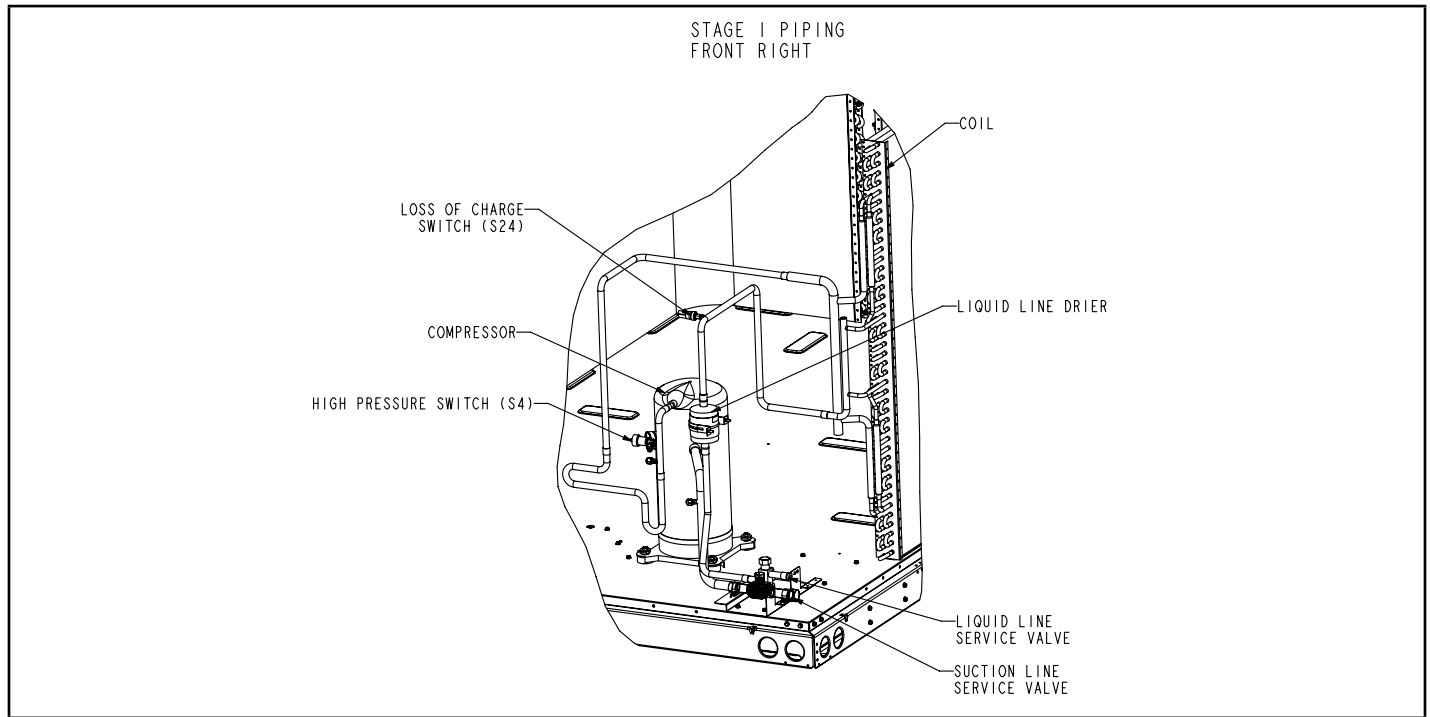

ELS240S4D – STAGE 2

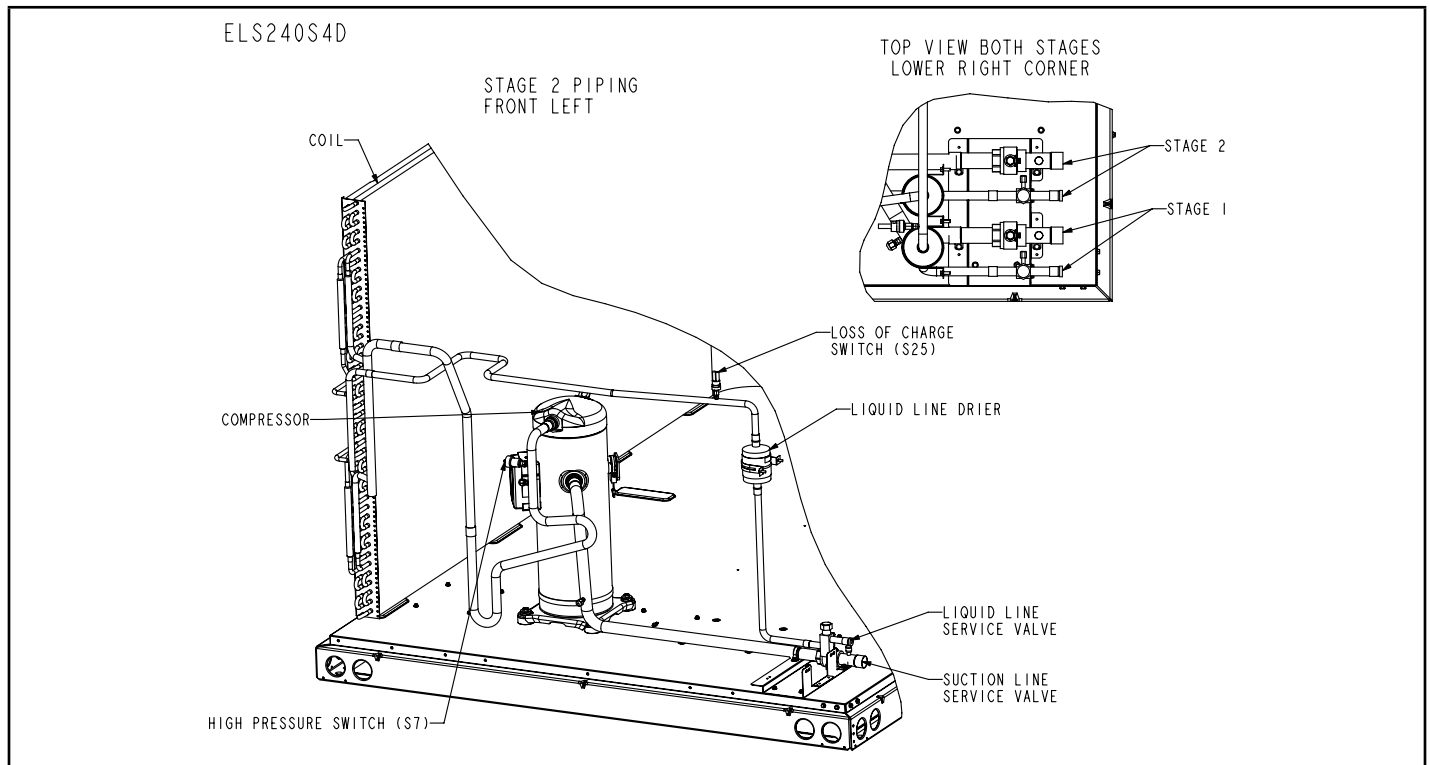

ELS240S4D – STAGE 1

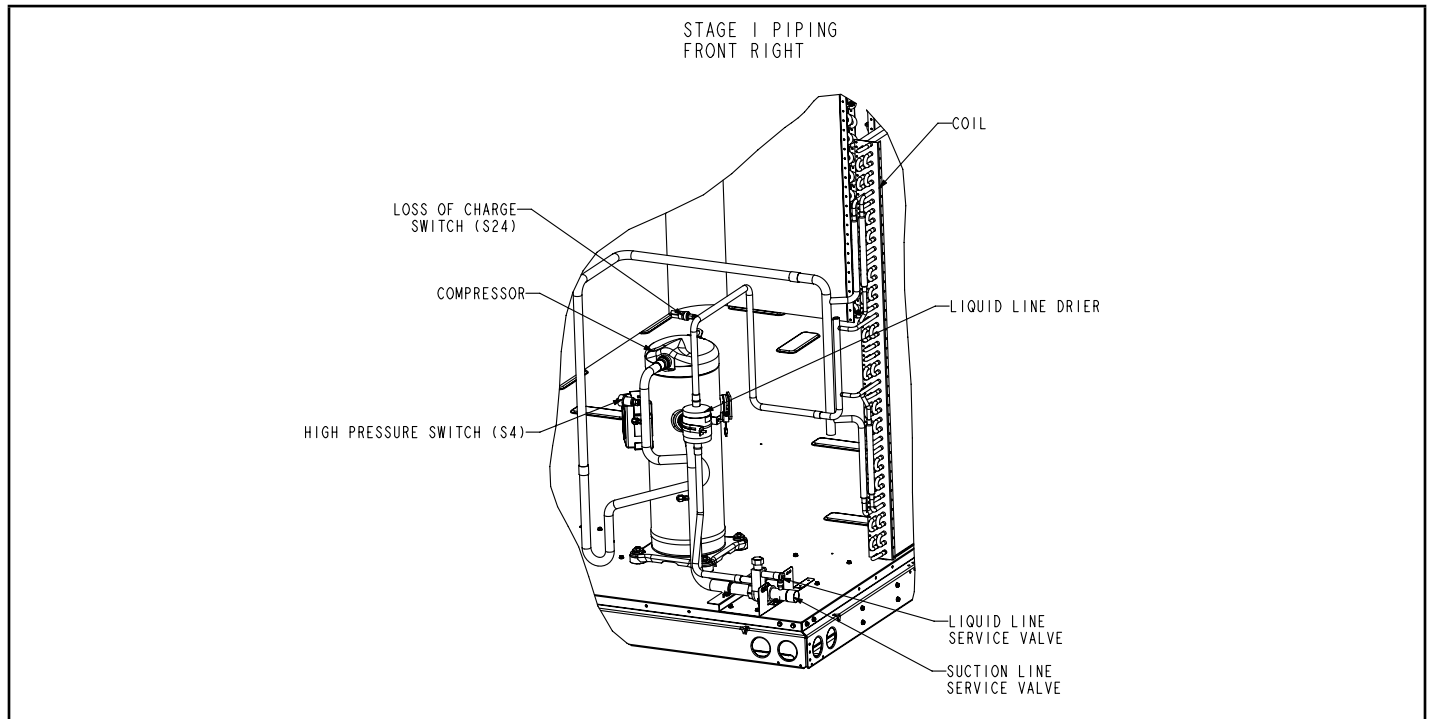

Model Number Identification

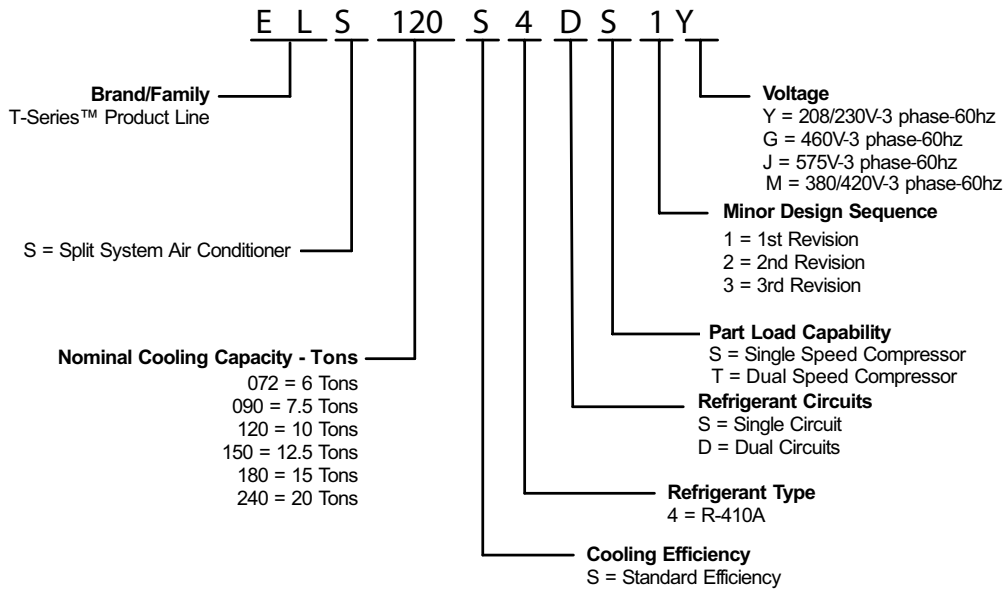

Unit Control Box Components Arrangement

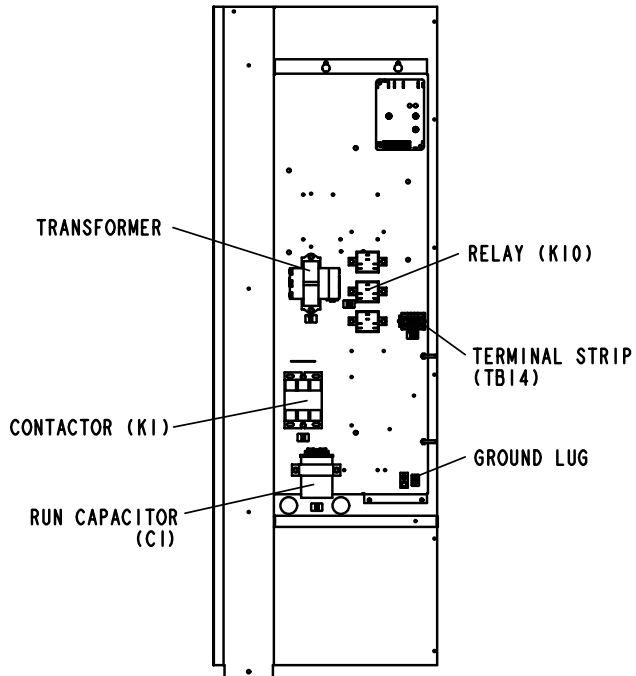

ELS072/090S

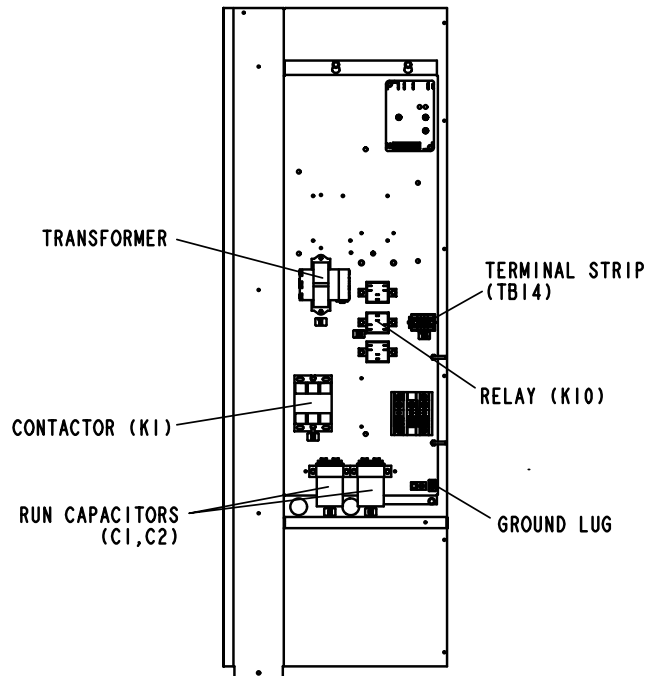

ELS120S

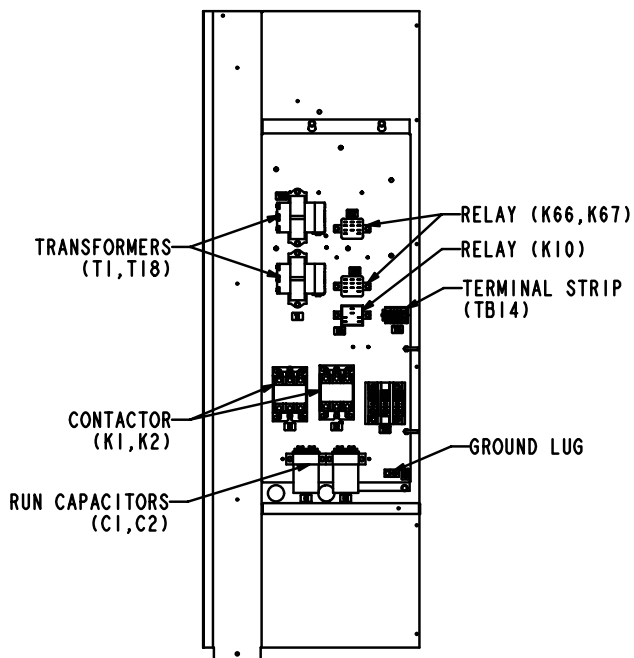

ELS120D/ELS150D

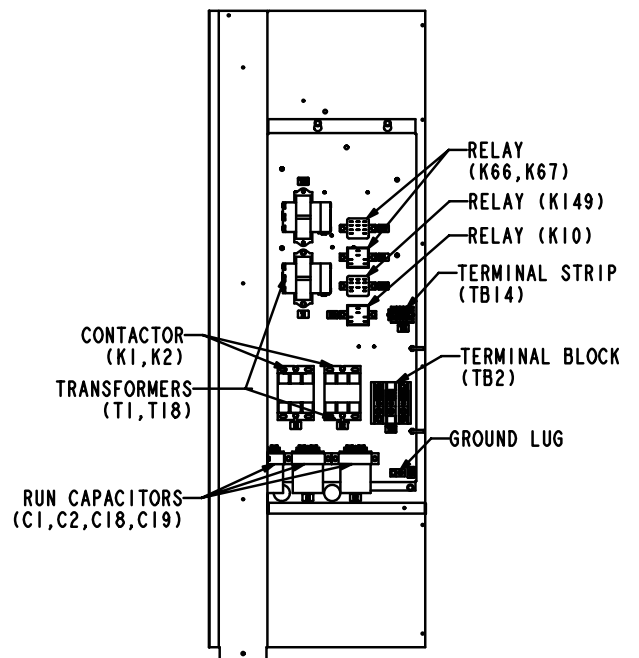

ELS180D/ELS240D

Rigging the Unit for Lifting

Rig the unit for lifting by attaching four cables to the holes in the base rail of the unit. See figures 1 through 3.

- 1 - Remove protective packaging before rigging the unit for lifting.
- 2 - Connect the rigging to the holes in each corner of the unit's base.
- 3 - All panels must be in place for rigging.
- 4 - Place a field-provided H-style frame just above the top edge of the unit. The frame must be of adequate strength and length. (An H-style frame will prevent the top of the unit from being damaged.)

Lifting point should be directly above the center of gravity.

Caution - do not walk on unit.

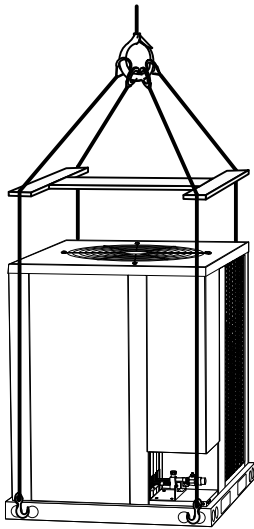

Important - all panels must be in place for rigging.

FIGURE 1. ELS072S4S and ELS090S4S

Lifting point should be directly above the center of gravity.

Caution - do not walk on unit.

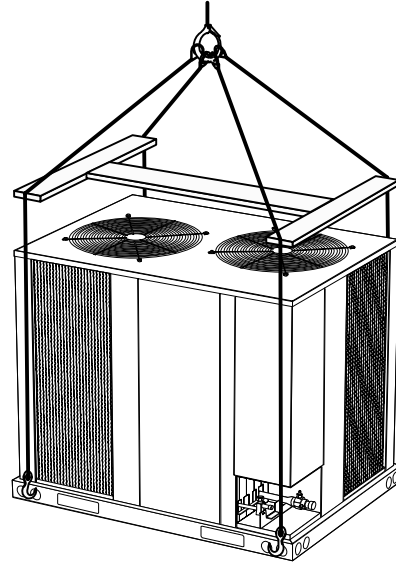

Important - all panels must be in place for rigging.

**FIGURE 2. ELS120S4S, ELS120S4D
and ELS150S4D**

Lifting point should be directly above the center of gravity.

Caution - do not walk on unit.

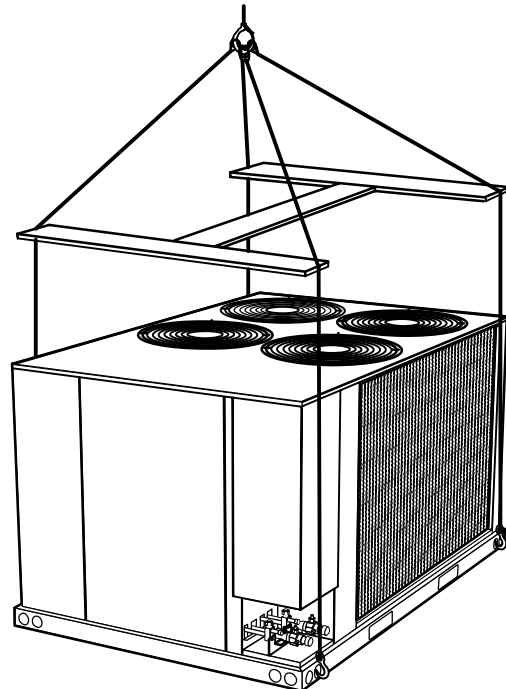

Important - all panels must be in place for rigging.

FIGURE 3. ELS180S4D and ELS240S4D

Installation Clearances

See Unit Dimensions on page 2 for sizing mounting slab, platforms or supports. Refer to figures 4 through 6 for mandatory installation clearance requirements.

NOTES:

- Clearance to one of the remaining two sides may be 12 in. (305 mm) and the final side may be 6 in. (152 mm).
- A clearance of 24 in. (610 mm) must be maintained between two units.
- 48 in. (1219 mm) clearance required on top of unit.

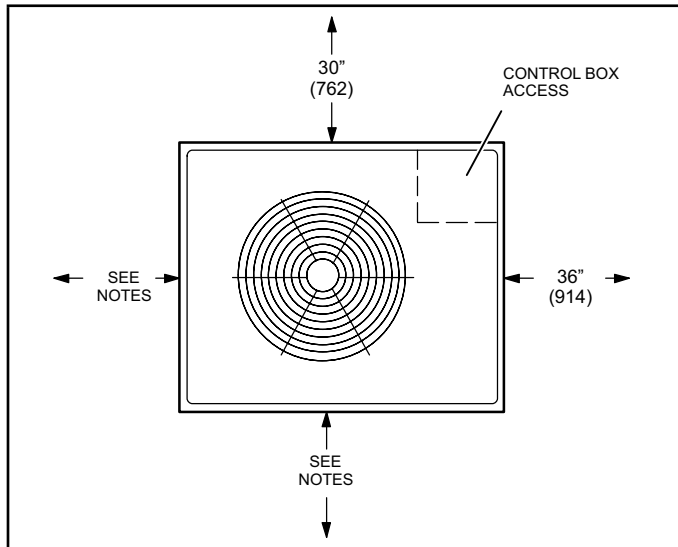

FIGURE 4. ELS072 and ELS090 Installation Clearances

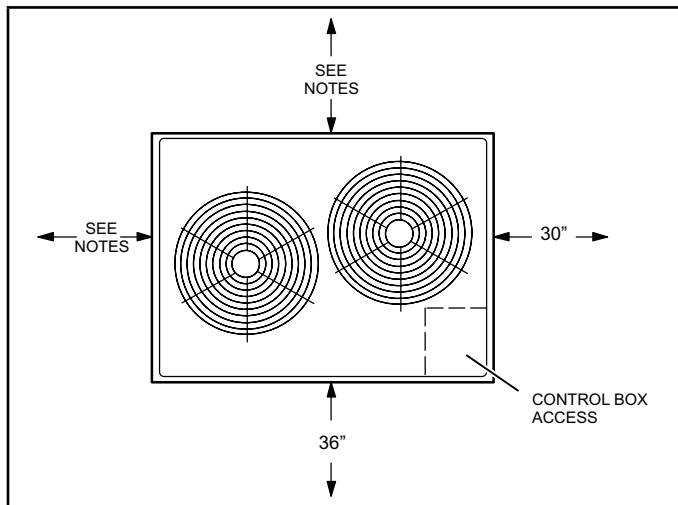

FIGURE 5. ELS120S4S, ELS120S4D and ELS150 Installation Clearances

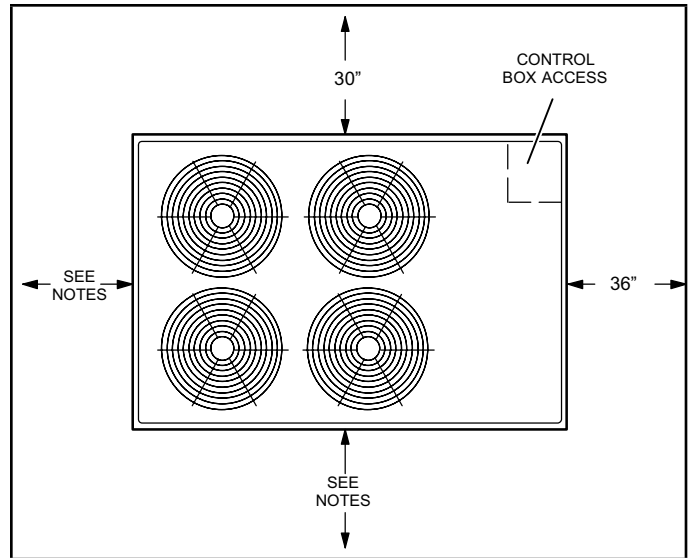

FIGURE 6. ELS180 and ELS240 Installation Clearances

Line Set

Field refrigerant piping consists of liquid and suction lines connecting the condensing unit and the indoor unit. Liquid and suction service valves are located in a compartment at the corner of the unit below the control box.

Piping can be routed directly from the service valves or field supplied elbows can be added to divert the piping as required.

Refer to table 1 for field-fabricated refrigerant line sizes for runs up to 50 linear feet (15 m).

TABLE 1. Refrigerant Line Sizes for Runs Up to 50 Linear Feet

Unit	Liquid Line	Suction Line
ELS072	3/8" (10mm)	1-1/8" (29mm)
ELS090	5/8" (16mm)	1-1/8" (29mm)
ELS120S4S	5/8" (16mm)	1-1/8" (29mm)
ELS120S4D	3/8" (10mm)	1-1/8" (29mm)
ELS150	3/8" (10mm)	1-1/8" (29mm)
ELS180	5/8" (16mm)	1-1/8" (29mm)
ELS240	5/8" (16mm)	1-1/8" (29mm)

Refrigerant Line Limitations

You may install the unit in applications that have line set lengths of up to 50 linear feet (15 m) with refrigerant line sizes as outlined in table 1 (excluding equivalent length of fittings). Size refrigerant lines greater than 50 linear feet (15m or greater) according to the Allied Refrigerant Piping Design and Fabrication Guidelines (Corp. 9351-L9) or latest version.

Electrical Connections

In the United States, wiring must conform with current local codes and the current National Electric Code (NEC). In Canada, wiring must conform with current local codes and the current Canadian Electrical Code (CEC).

TRANSFORMER – 24V

Use the transformer provided with the air conditioning unit for low-voltage control power (24V, 70VA)

NOTE – The addition of accessories to the system could exceed the 70VA power requirement of the factory-provided transformer. Measure the system's current and voltage after installation is complete to determine transformer loading. If loading exceeds the factory-provided transformer capacity, a larger field-provided transformer will need to be installed in the system.

1 CIRCUIT SIZING AND DISCONNECT SWITCH

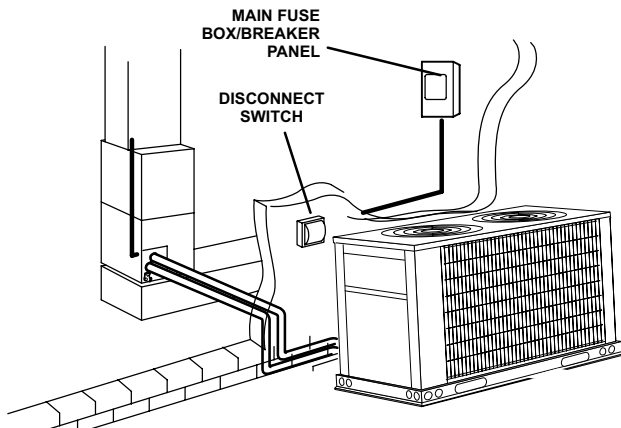

Refer to the unit nameplate for minimum circuit ampacity, amperage minimum, and maximum fuse or circuit breaker fusible (HACR per NEC). Install power wiring and properly sized disconnect switch.

NOTE — UNITS ARE APPROVED FOR USE ONLY WITH COPPER CONDUCTORS. GROUND UNIT AT DISCONNECT SWITCH OR TO AN EARTH GROUND.

2 TYPICAL HIGH VOLTAGE POWER SUPPLY CONNECTIONS

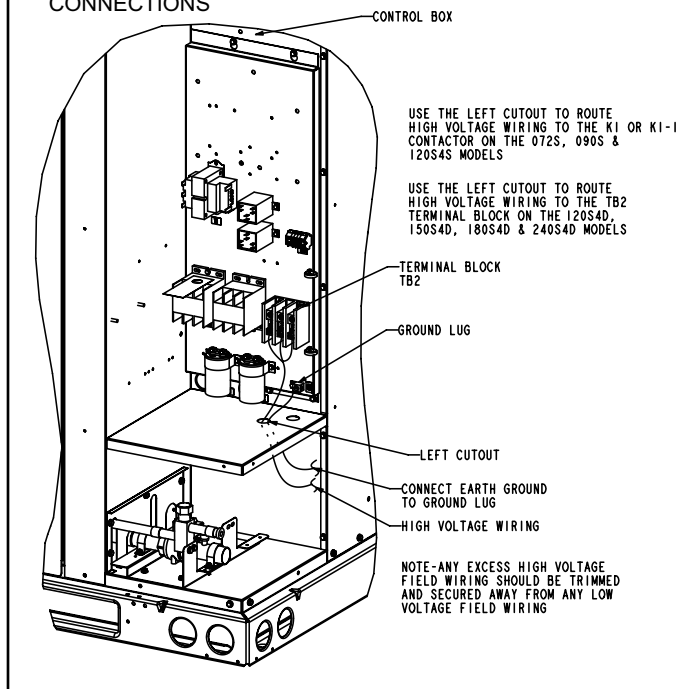

3 INSTALL THERMOSTAT

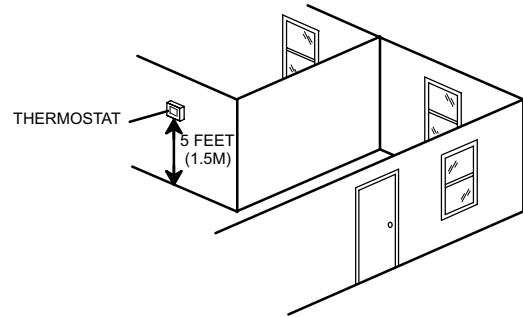

Install room thermostat (ordered separately) on an inside wall approximately in the center of the conditioned area and 5 feet (1.5m) from the floor. It should not be installed on an outside wall or where it can be affected by sunlight, drafts or vibrations.

4 TYPICAL CONTROL WIRING

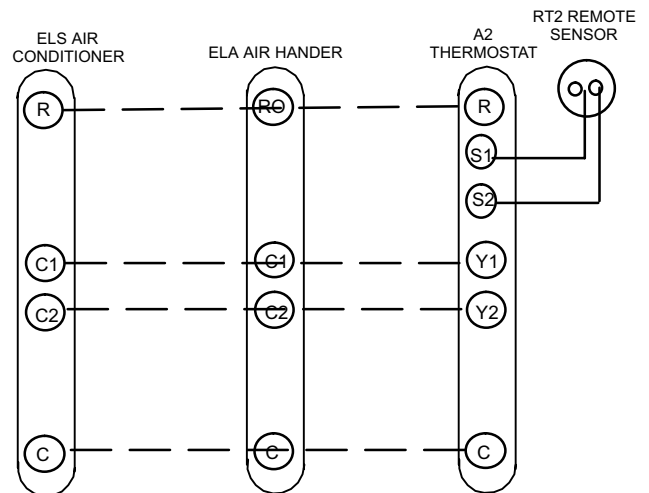

Install low voltage wiring from outdoor to indoor unit and from thermostat to indoor unit as illustrated.

⚠ WARNING



Electric Shock Hazard. Can cause injury or death. Unit must be properly grounded in accordance with national and local codes.

Line voltage is present at all components when unit is not in operation on units with single-pole contactors. Disconnect all remote electric power supplies before opening access panel. Unit may have multiple power supplies.

5 TYPICAL UNIT CONTROL WIRE CONNECTIONS

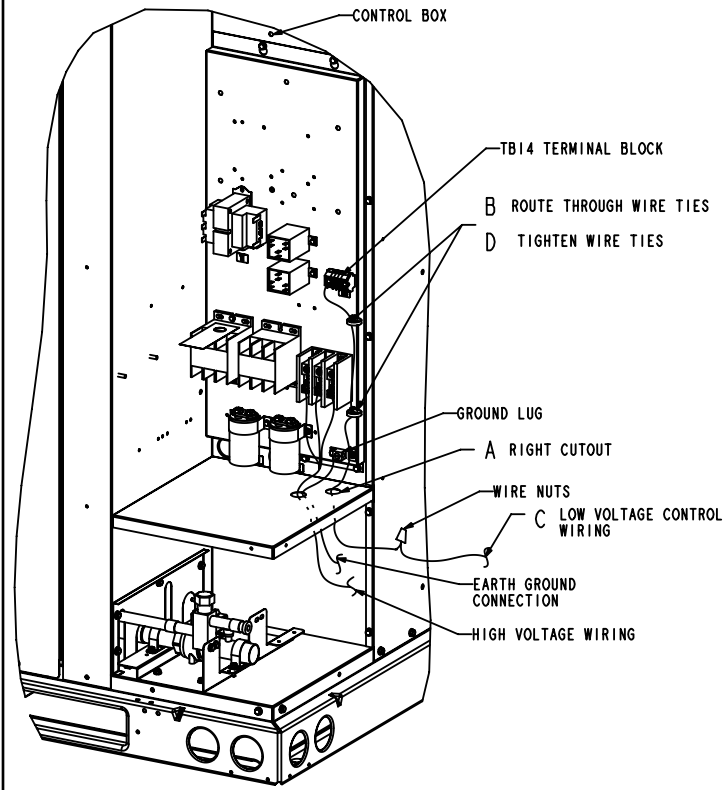

WIRE RUN LENGTH	AWG#	INSULATION TYPE
LESS THAN 100' (30M)	18	TEMPERATURE RATING
MORE THAN 100' (30M)	16	35°C MINIMUM

- A RUN CONTROL WIRES THROUGH RIGHT CUTOUT.
- B RUN CONTROL WIRES THROUGH WIRE TIES.
- C MAKE CONTROL WIRE CONNECTIONS USING FIELD PROVIDED WIRE NUTS. SEE FIGURES 7 THROUGH 10 FOR CONNECTION REQUIREMENTS.
- D TIGHTEN WIRE TIE TO SECURE 24VDC CONTROL WIRING.

NOTE - FOR PROPER VOLTAGES, SELECT THERMOSTAT WIRE (CONTROL WIRING) GAUGE PER TABLE ABOVE.

NOTE - WIRE TIE PROVIDES LOW VOLTAGE WIRE STRAIN RELIEF AND MAINTAINS SEPARATION OF FIELD INSTALLED LOW AND HIGH VOLTAGE CIRCUITS.

NOTE - DO NOT BUNDLE ANY EXCESS 24VAC CONTROL WIRES INSIDE CONTROL BOX.

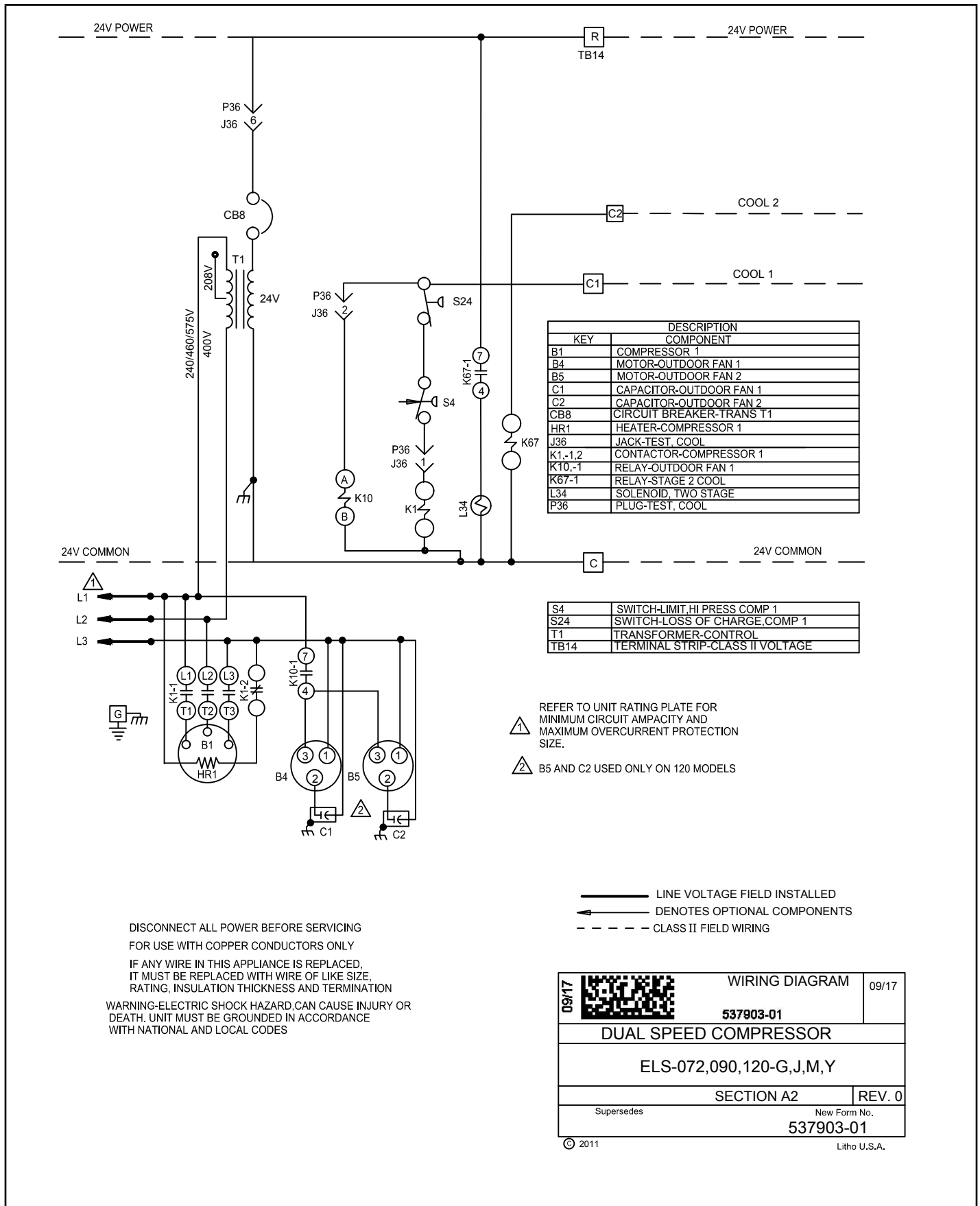
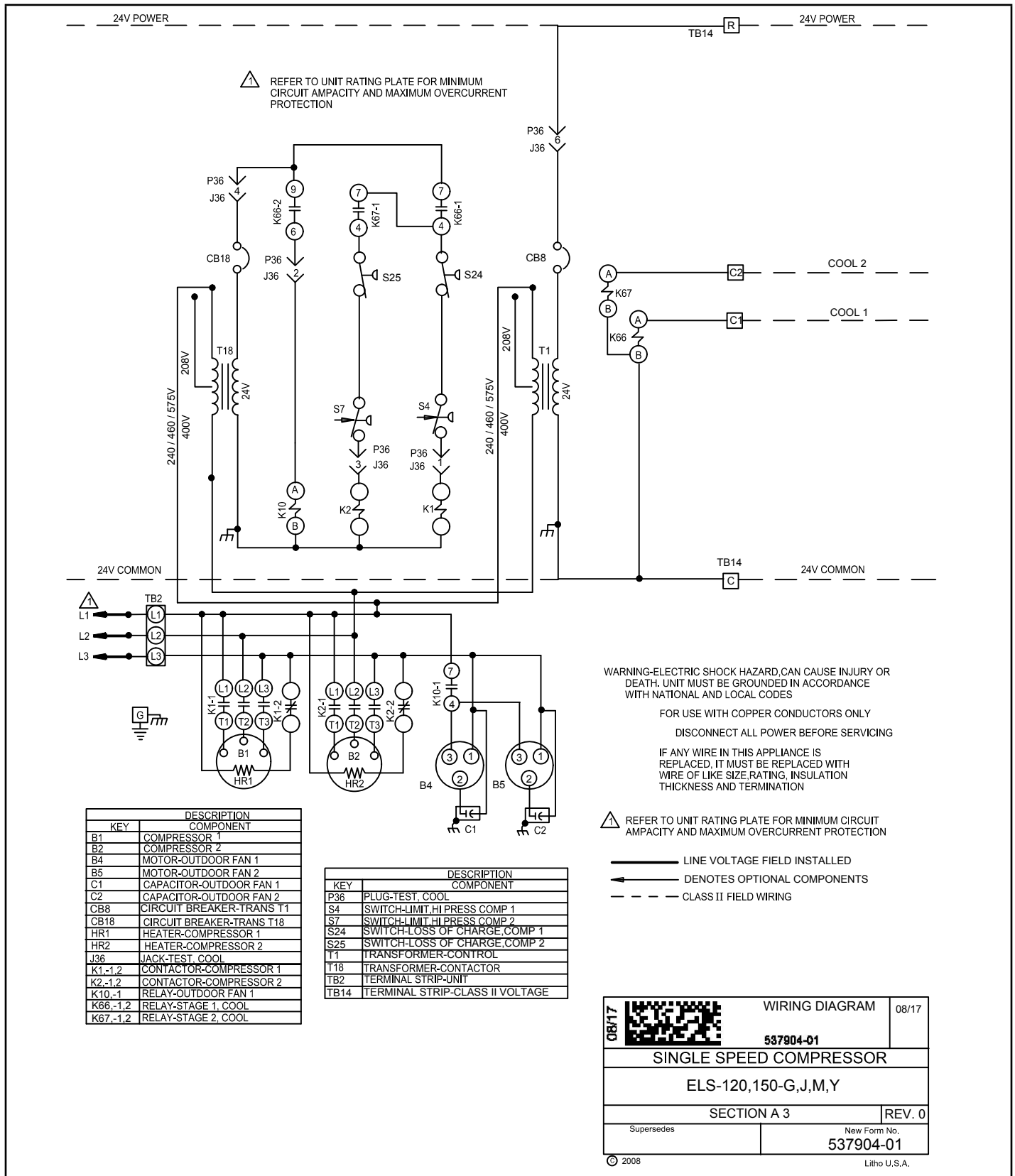

FIGURE 7. Typical Wiring Diagram – ELS072S4S, ELS090S4S and ELS120S4S (G, J, M, Y Voltages)



KEY	DESCRIPTION COMPONENT
B1	COMPRESSOR 1
B2	COMPRESSOR 2
B4	MOTOR-OUTDOOR FAN 1
B5	MOTOR-OUTDOOR FAN 2
C1	CAPACITOR-OUTDOOR FAN 1
C2	CAPACITOR-OUTDOOR FAN 2
CB8	CIRCUIT BREAKER-TRANS T1
CB18	CIRCUIT BREAKER-TRANS T18
HR1	HEATER-COMPRESSOR 1
HR2	HEATER-COMPRESSOR 2
J36	JACK-TEST, COOL
K1,-1,2	CONTACTOR-COMPRESSOR 1
K2,-1,2	CONTACTOR-COMPRESSOR 2
K10,-1	RELAY-OUTDOOR FAN 1
K66,-1,2	RELAY-STAGE 1, COOL
K67,-1,2	RELAY-STAGE 2, COOL

KEY	DESCRIPTION COMPONENT
P36	PLUG-TEST, COOL
S4	SWITCH-LIMIT HI PRESS COMP 1
S7	SWITCH-LIMIT HI PRESS COMP 2
S24	SWITCH-LOSS OF CHARGE, COMP 1
S25	SWITCH-LOSS OF CHARGE, COMP 2
T1	TRANSFORMER-CONTROL
T18	TRANSFORMER-CONTACTOR
TB2	TERMINAL STRIP-UNIT
TB14	TERMINAL STRIP-CLASS II VOLTAGE

08/17		WIRING DIAGRAM	08/17
		537904-01	
SINGLE SPEED COMPRESSOR			
ELS-120,150-G,J,M,Y			
SECTION A 3		REV. 0	
Supersedes		New Form No. 537904-01	
© 2008		Litho U.S.A.	

FIGURE 8. Typical Wiring Diagram – ELS120S4D and ELS150S4D (G, J, M, Y Voltages)

Refrigerant Charge

ELS units have a factory holding charge of 2 pounds of HFC-410A in each circuit. Additional refrigerant will need to be added during installation (table 2).

TABLE 2. Adding Refrigerant

Models	Stage 1 lbs for 25ft line set	Stage 2 lbs for 25ft line set	Liq. Line Dia.	Suction Line Dia.	Ounces Adjustment per foot of line set ¹
ELS072S4S	18.5	N/A	3/8	1-1/8	0.7
ELS090S4S	21.75	N/A	5/8	1-1/8	1.7
ELS120S4S	23	N/A	5/8	1-1/8	1.7
ELS120S4D	12	12	3/8	1-1/8	0.7
ELS150S4D	15	15.5	3/8	1-1/8	0.7
ELS180S4D	23.75	23.5	5/8	1-1/8	1.7
ELS240S4D	22.5	23.5	5/8	1-1/8	1.7

¹ If line set length is greater than 25 feet, add this amount to each circuit. If line set is less than 25 feet, subtract this amount from each circuit. Refer to *Allied Refrigerant Piping Design and Fabrication Guidelines* for more information.

NOTE - Refrigerant line sets longer than 200 feet (60 meters) are not recommended. For assistance contact Allied Application Department.

To charge the system, use either of the following procedures:

CHARGE PROCEDURE – NORMAL OPERATING PRESSURES

- 1 - Connect a manifold gauge set to the service valves:
 - A - Low pressure gauge to vapor service port.
 - B - High pressure gauge to liquid valve service port
- 2 - Operate system until pressures and temperatures stabilize (5 minutes minimum).
- 3 - Use a thermometer to measure the outdoor ambient temperature. The outdoor temperature will determine which charging procedure to use.

Outdoor Temp > 65°F (18°C)

- 1 - Apply the outdoor ambient temperature to table 4 or 5 to determine normal operating pressures. Compare the normal operating pressures to the pressures obtained from the connected gauges. If discharge pressure is high, remove refrigerant from the system. If discharge pressure is low, add refrigerant to the system.
 - A - Add or remove charge in increments.
 - B - Allow the system to stabilize at least 5 minutes each time refrigerant is added or removed
- 2 - Minor variations in these pressures may be expected due to differences in installations. Significant differences could mean that the system is not properly charged or that a problem exists with some component in the system.

- 3 - Verify the charge, as described in the approach method.

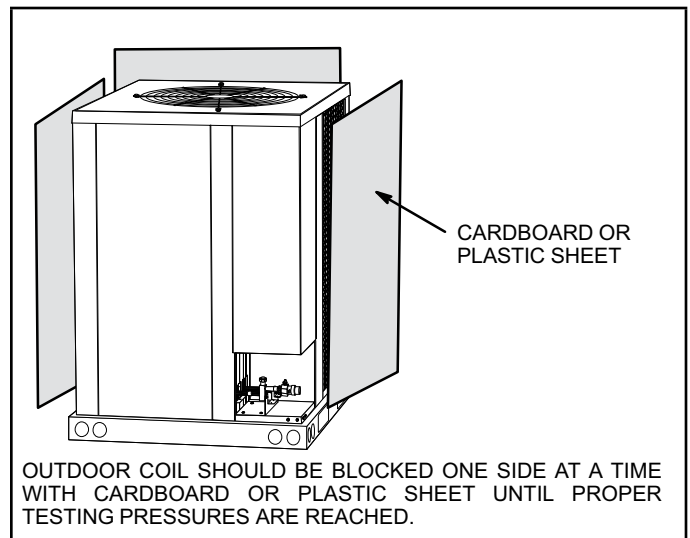

FIGURE 10. Blocking Outdoor Coil

Outdoor Temp < 65°F (18°C)

- 1 - When the outdoor ambient temperature is below 65F (18C) it may be necessary to restrict the air flow through the outdoor coil to achieve liquid pressures in the 325-375 psig (2240-2585 kPa) range. These higher pressures are necessary for checking the charge. Block equal sections of the outdoor coil on all coil sides until the liquid pressure is in the 325-375 psig range (figure 11).
- 2 - Charge the unit using the approach method in the next section.

CHARGE PROCEDURE – APPROACH METHOD

Use the following approach method along with the normal operating pressures to confirm readings.

- 1 - Using the same thermometer, compare liquid temperature at service valve to outdoor ambient temperature.

Approach Temperature = Liquid temperature minus ambient temperature

- 2 - Approach temperature should be as indicated in table 3 for each stage. An approach temperature greater than this value indicates an undercharge. An approach temperature less than this value indicates an overcharge.
 - A - Add or remove charge in increments.
 - B - Allow system to stabilize at least 5 minutes each time refrigerant is added or removed.
- 3 - Do not use the approach method if system pressures do not match pressures in table 4 except when the outdoor ambient temperature is below 65°F (18°C). The approach method is not valid for grossly over or undercharged systems.

TABLE 3. HFC-410A Approach Temperatures*

Models	Stage	Approach Temperature (°F) (+/- 1)	Approach Temperature (°C) (+/- 0.5)
ELS072S4S	1	5.0	2.8
ELS090S4S	1	7.0	3.9
ELS120S4S	1	5.0	2.8
ELS120S4D	1	5.0	2.8
	2	5.0	2.8
ELS150S4D	1	7.0	3.9
	2	5.0	2.8
ELS180S4D	1	3.0	1.7
	2	4.0	2.2
ELS240S4D	1	3.0	1.7
	2	6.0	3.3

*Approach temperature method valid at full load 100% IEER laboratory conditions.

TABLE 4. HFC-410A Normal Operating Pressures (Liquid ±10 and Suction ±5 psig) (Single-Stage Units)**

Temp*	-072S4S		-090S4S		-120S4S	
	Liquid	Suction	Liquid	Suction	Liquid	Suction
65° F (18° C)	245	136	261	123	239	132
75° F (24° C)	281	142	294	130	277	135
85° F (29° C)	325	144	338	131	320	138
95° F (35° C)	378	145	385	133	366	140
105° F (41° C)	424	150	435	135	417	142
115° F (46° C)	478	153	489	136	471	143
125° F (52° C)	540	155	545	140	529	144
STD. CFM	2600		2725		3850	

*Temperature of air entering outdoor Coil

**With indoor conditions at 80°F dry bulb and 67°F wet bulb temperatures.

TABLE 5. HFC-410A Normal Operating Pressures (Liquid ±10 and Suction ±5 psig) (Two-Stage Units)**

Temp*	-120S4D STAGE 1		-120S4D STAGE 2		-150S4D STAGE 1		-150S4D STAGE 2	
	Liquid	Suction	Liquid	Suction	Liquid	Suction	Liquid	Suction
65° F (18° C)	244	133	239	133	254	132	254	130
75° F (24° C)	283	136	278	134	294	135	293	133
85° F (29° C)	325	138	322	136	338	137	337	134
95° F (35° C)	372	140	369	138	381	140	382	136
105° F (41° C)	422	142	421	140	432	142	434	139
115° F (46° C)	476	144	477	142	487	144	489	141
125° F (52° C)	534	146	536	144	543	147	550	145
STD. CFM	4000				4400			

Temp*	-180S4D STAGE 1		-180S4D STAGE 2		-240S4D STAGE 1		-240S4D STAGE 2	
	Liquid	Suction	Liquid	Suction	Liquid	Suction	Liquid	Suction
65° F (18° C)	236	111	230	108	232	129	238	127
75° F (24° C)	277	121	270	117	272	131	277	128
85° F (29° C)	322	130	314	123	317	133	322	130
95° F (35° C)	368	136	361	128	366	136	362	132
105° F (41° C)	421	139	411	129	417	138	424	135
115° F (46° C)	481	141	461	131	472	141	477	138
125° F (52° C)	543	143	523	133	532	145	531	144
STD. CFM	5150				6975			

*Temperature of air entering outdoor Coil

**With indoor conditions at 80°F dry bulb and 67°F wet bulb temperatures.

TABLE 6. HFC-410A Temperature (°F) - Pressure (Psig)

°F	Psig	°F	Psig	°F	Psig	°F	Psig	°F	Psig	°F	Psig	°F	Psig	°F	Psig
32	100.8	48	137.1	63	178.5	79	231.6	94	290.8	110	365.0	125	445.9	141	545.6
33	102.9	49	139.6	64	181.6	80	235.3	95	295.1	111	370.0	126	451.8	142	552.3
34	105.0	50	142.2	65	184.3	81	239.0	96	299.4	112	375.1	127	457.6	143	559.1
35	107.1	51	144.8	66	187.7	82	242.7	97	303.8	113	380.2	128	463.5	144	565.9
36	109.2	52	147.4	67	190.9	83	246.5	98	308.2	114	385.4	129	469.5	145	572.8
37	111.4	53	150.1	68	194.1	84	250.3	99	312.7	115	390.7	130	475.6	146	579.8
38	113.6	54	152.8	69	197.3	85	254.1	100	317.2	116	396.0	131	481.6	147	586.8
39	115.8	55	155.5	70	200.6	86	258.0	101	321.8	117	401.3	132	487.8	148	593.8
40	118.0	56	158.2	71	203.9	87	262.0	102	326.4	118	406.7	133	494.0	149	601.0
41	120.3	57	161.0	72	207.2	88	266.0	103	331.0	119	412.2	134	500.2	150	608.1
42	122.6	58	163.9	73	210.6	89	270.0	104	335.7	120	417.7	135	506.5	151	615.4
43	125.0	59	166.7	74	214.0	90	274.1	105	340.5	121	423.2	136	512.9	152	622.7
44	127.3	60	169.6	75	217.4	91	278.2	106	345.3	122	428.8	137	519.3	153	630.1
45	129.7	61	172.6	76	220.9	92	282.3	107	350.1	123	434.5	138	525.8	154	637.5
46	132.2	62	175.4	77	224.4	93	286.5	108	355.0	124	440.2	139	532.4	155	645.0
47	134.6			78	228.0			109	360.0			140	539.0		

System Operation

The outdoor unit and indoor blower cycle on demand from the room thermostat. When the thermostat blower switch is in the ON position, the indoor blower operates continuously.

HIGH PRESSURE SWITCHES (S4 AND S7)

These units are equipped with a manual reset high pressure switch (single-pole, single-throw) which is located on the discharge line. The switch shuts off the compressor when discharge pressure rises above the factory setting. High Pressure (auto reset) – trip at 640 psig; reset at 512 psig.

LOSS OF CHARGE SWITCHES (S24 AND S25)

These units are equipped with a loss-of-charge switch that is located in the liquid line. The switch is a SPST, auto-reset switch that is normally closed. The switch opens at 40 psi and closes at 90 psi.

Maintenance

At the beginning of each cooling season, the system should be checked as follows:

OUTDOOR UNIT

- 1 - Clean and inspect the condenser coil. You can flush the coil with a water hose.
- 2 - The outdoor fan motor is prelubricated and sealed. No further lubrication is necessary.
- 3 - Visually inspect connecting lines and coils for evidence of oil leaks.
- 4 - Check wiring for loose connections.
- 5 - Check for correct voltage at the unit while the unit is operating and while it is off.
- 6 - Check amp-draw of the outdoor fan motor.
Unit nameplate _____ Actual _____
- 7 - Check amp-draw of the compressor.
Unit nameplate _____ Actual _____

NOTE — If the owner complains of insufficient cooling, gauge the unit and check the refrigerant charge. Refer to section on refrigerant charging in this instruction.

INDOOR COIL

- 1 - If necessary, clean the coil.
- 2 - Check connecting lines and coils for evidence of oil leaks.
- 3 - If necessary, check the condensate line and clean it.

INDOOR UNIT

- 1 - Clean or change filters.
- 2 - Adjust the blower speed for cooling. Measure the pressure drop over the coil to determine the correct blower CFM. Refer to the unit information service manual for pressure drop tables and procedure.
- 3 - On belt drive blowers, check the belt for wear and proper tension.

- 4 - Check all wiring for loose connections.
- 5 - Check for correct voltage at the unit (blower operating).
- 6 - Check amp-draw on blower motor.
Unit nameplate _____ **Actual** _____

Start-Up and Performance Checklist

Job Name _____		Job no. _____	Date _____
Job Location _____		City _____	State _____
Installer _____		City _____	State _____
Unit Model No. _____	Serial No. _____	Service Technician _____	
Nameplate Voltage _____			
Rated Load Ampacity _____		Compressor Amperage: _____	
Maximum Fuse or Circuit Breaker _____			
Electrical Connections Tight? <input type="checkbox"/>	Indoor Filter clean? <input type="checkbox"/>	Supply Voltage (Unit Off) _____	
Indoor Blower RPM _____	S.P. Drop Over Indoor (Dry) _____	Outdoor Coil Entering Air Temp. _____	
Vapor Pressure; _____			
Refrigerant Lines: - Leak Checked? <input type="checkbox"/>		Properly Insulated? <input type="checkbox"/>	Outdoor Fan Checked? <input type="checkbox"/>
Service Valves: --- Fully Opened? <input type="checkbox"/>		Caps Tight? <input type="checkbox"/>	Voltage With Compressor Operating _____
SEQUENCE OF OPERATION		THERMOSTAT	
Heating Correct? <input type="checkbox"/>	Cooling Correct? <input type="checkbox"/>	Calibrated? <input type="checkbox"/>	Properly Set? <input type="checkbox"/> Level? <input type="checkbox"/>