

SERVICE MANUAL

A93DF1E / 92G1DFE



This is a safety alert symbol and should never be ignored. When you see this symbol on labels or in manuals, be alert to the potential for personal injury or death.



Table of Contents

Technical Specifications - A93DF1E.....	2
Technical Specifications - 92G1DFE	5
Parts Arrangement.....	8
Electrical.....	9
Placement & Installation.....	23
Joint Cementing Procedure.....	24
Venting Practices.....	25
Vent Piping Guidelines	26
Condensate Piping	39
Start-Up.....	43
Heating System Service Checks	44
Typical Operating Characteristics.....	48
Maintenance.....	49
Wiring Diagram.....	52
Troubleshooting: Heating Sequence of Operation	53
Troubleshooting: Heating Sequence of Operation (Continued).....	54
Troubleshooting: Cooling Sequence of Operation.....	55
Troubleshooting: Continuous Fan / Accessories Sequence of Operation.....	56

WARNING

Improper installation, adjustment, alteration, service or maintenance can cause property damage, personal injury or loss of life. Installation and service must be performed by a licensed professional HVAC installer (or equivalent), service agency or the gas supplier.

WARNING



Electric shock hazard.

Can cause injury or death. Before attempting to perform any service or maintenance, turn the electrical power to unit OFF at disconnect switch(es). Unit may have multiple power supplies.

CAUTION

As with any mechanical equipment, contact with sharp sheet metal edges can result in personal injury. Take care while handling this equipment and wear gloves and protective clothing.



(P) 508134-01

Technical Specifications - A93DF1E

MODEL NUMBER GUIDE

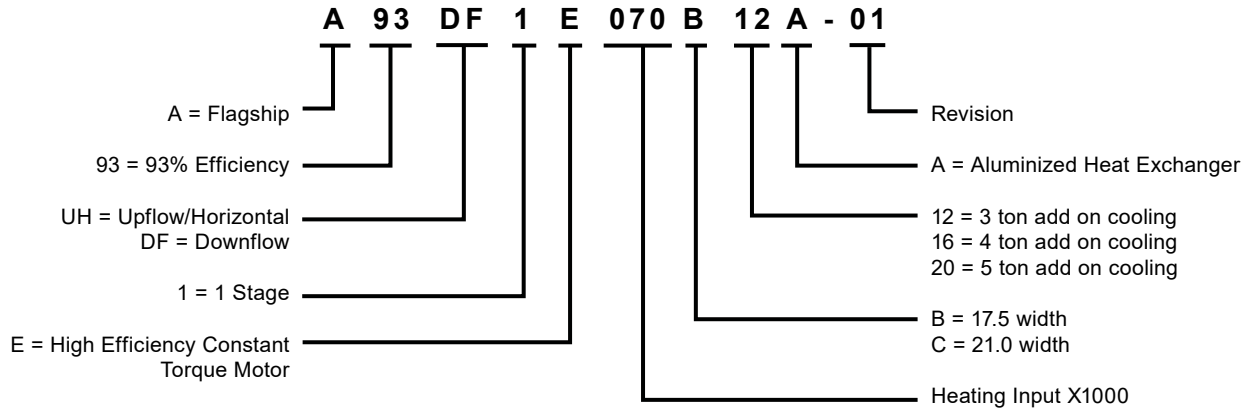

PHYSICAL AND ELECTRICAL DATA

	Model	Input (Btuh)	Output (Btuh)	AFUE (ICS)	Nominal Cooling Capacity	Gas Inlet (in.)	Volts/Hz/Phase	Max Time Delay Breaker or Fuse	Nominal F.L.A.	Trans. (V.A.)	Approx. Shipping Weight (lbs.)
Downflow	A93DF1E045B12A	44000	42000	93.0%	1.5 - 3	1/2	120 - 60 - 1	15	6.8	40	131
	A93DF1E070B12A	66000	63000	93.0%	1.5 - 3	1/2	120 - 60 - 1	15	6.8	40	135
	A93DF1E090C16A	88000	84000	93.0%	2.5 - 4	1/2	120 - 60 - 1	15	8.4	40	153

Note: For vent length and clearances to combustibles, please reference installation instructions.

BLOWER PERFORMANCE DATA

	Model	Motor Size (hp)	Blower Size	Temp. Rise (°F)	Blower speed	Heating cfm @ .10" - .80" w.c.							
						0.10	0.20	0.30	0.40	0.50	0.60	0.70	0.80
Downflow	A93DF1E045B12A	1/2	10 x 8	25 - 55	High	1395	1365	1330	1305	1275	1245	NA	NA
					Med/High	1270	1245	1215	1180	1140	1110	1080	1030
					Med	1145	1105	1070	1025	980	950	910	870
					Med/Low	845	795	740	700	660	615	585	545
					Low	695	640	575	530	485	445	390	335
	A93DF1E070B12A	1/2	10 x 8	40 - 70	High	1380	1345	1325	1295	1260	1235	1185	NA
					Med/High	1265	1240	1215	1175	1135	1105	1080	1040
					Med	1140	1090	1060	1025	985	955	910	865
					Med/Low	860	810	770	710	670	620	585	540
					Low	700	645	590	530	490	440	395	340
	A93DF1E090C16A	3/4	10 x 10	45 - 75	High	1695	1680	1640	1605	1575	1550	1490	NA
					Med/High	1495	1445	1410	1385	1355	1310	1265	1240
					Med	1365	1315	1285	1245	1215	1165	1125	1075
					Med/Low	1265	1240	1200	1160	1115	1085	1030	995
					Low	1160	1110	1070	1020	975	925	885	825

ACCESSORIES

System Accessory	Kit Number	Description
External Filter Rack	1.841018	1 pack (16 x 25)
	1.841039	10 pack (16 x 25)
Natural to LP Kit	11K50	1-Stage - 90
	11K45	High Altitude (>7500')
	17H62	1-Stage - 90% - for 030 Capacity ONLY
	17H90	High Altitude (>7500') - 030 Capacity Only
Return Air Base	68W62	17.5" B Width
	68W63	21.0" C Width
Downflow Combustible Flooring Base	11M60	17.5" B Width
	11M61	21.0" C Width
Night Service Kit	84W48	Single Stage
Horizontal Suspension Kit	51W10	80% & 90% Kit
Flush Mount Termination (90% Furnaces Only) (US Only)	51W11	2" & 3" Vent Version
Concentric Vent Kit (90% Furnaces Only) (US Only)	71M80	1-1/2" Vent Version
	69M29	2" Vent Version
	60L46	3" Vent Version
2-Stage Compressor Kit	85W66	Blower Relay Kit
Twinning Kit	16W72	Constant Torque Gas Furnace Twinning Kit

Note: For vent length and clearances to combustibles, please reference installation instructions.

Technical Specifications - 92G1DFE

MODEL NUMBER GUIDE

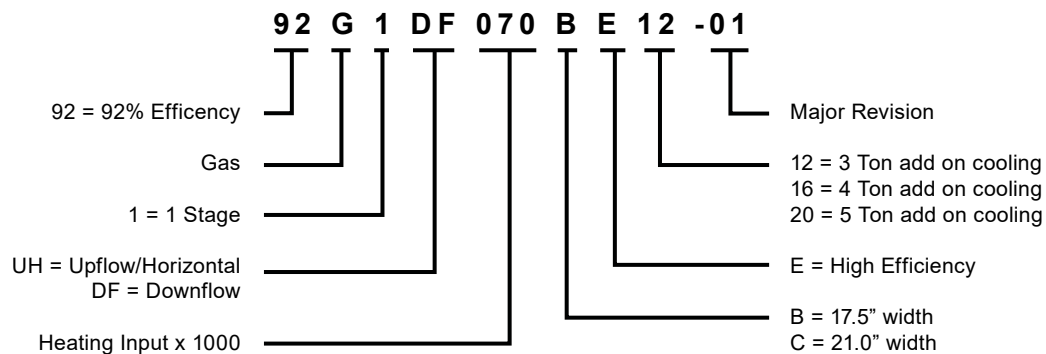

PHYSICAL AND ELECTRICAL DATA

	Model	Input (Btuh)	Output (Btuh)	AFUE (ICS)	Nominal Cooling Capacity	Gas Inlet (in.)	Volts/Hz/Phase	Max. Time Delay Breaker or Fuse	Nominal F.L.A.	Trans. (V.A.)	Approx. Shipping Weight (lbs.)
Downflow	92G1DF030BE12	44000	42000	92.1%	1.5 - 3	1/2	120 - 60 - 1	15	6.8	40	123.5
	92G1DF045BE12	66000	63000	92.1%	1.5 - 3	1/2	120 - 60 - 1	15	6.8	40	129.5
	92G1DF070BE16	88000	84000	92.1%	2.5 - 4	1/2	120 - 60 - 1	15	8.4	40	152.0

Note: For vent length and clearances to combustibles, please reference installation instructions.

BLOWER PERFORMANCE DATA

	Model	Motor Size (hp)	Blower Size	Temp. Rise (°F)	Blower speed	Heating cfm @ .10" - .80" w.c.							
						0.10	0.20	0.30	0.40	0.50	0.60	0.70	0.80
Downflow	92G1DF030BE12	1/2	10 x 8	25 - 55	High	1395	1365	1330	1305	1275	1245	NA	NA
					Med/High	1270	1245	1215	1180	1140	1110	1080	1030
					Med	1145	1105	1070	1025	980	950	910	870
					Med/Low	845	795	740	700	660	615	585	545
					Low	695	640	575	530	485	445	390	335
	92G1DF045BE12	1/2	10 x 8	40 - 70	High	1380	1345	1325	1295	1260	1235	1185	NA
					Med/High	1265	1240	1215	1175	1135	1105	1080	1040
					Med	1140	1090	1060	1025	985	955	910	865
					Med/Low	860	810	770	710	670	620	585	540
					Low	700	645	590	530	490	440	395	340
	92G1DF070BE16	3/4	10 x 10	45 - 75	High	1695	1680	1640	1605	1575	1550	1490	NA
					Med/High	1495	1445	1410	1385	1355	1310	1265	1240
					Med	1365	1315	1285	1245	1215	1165	1125	1075
					Med/Low	1265	1240	1200	1160	1115	1085	1030	995
					Low	1160	1110	1070	1020	975	925	885	825

ACCESSORIES

System Accessory	Kit Number	Description
External Filter Rack	1.841018	1 pack (16 x 25)
	1.841039	10 pack (16 x 25)
Natural to LP Kit	11K50	1-Stage - 90
	11K45	High Altitude (>7500')
	17H62	1-Stage - 90% - for 030 Capacity ONLY
	17H90	High Altitude (>7500') - 030 Capacity Only
Return Air Base	68W62	17.5" B Width
	68W63	21.0" C Width
Downflow Combustible Flooring Base	11M60	17.5" B Width
	11M61	21.0" C Width
Night Service Kit	18F15	Single Stage
Horizontal Suspension Kit	51W10	80% & 90% Kit
Flush Mount Termination (90% Furnaces Only) (US Only)	51W11	2" & 3" Vent Version
Concentric Vent Kit (90% Furnaces Only) (US Only)	71M80	1-1/2" Vent Version
	69M29	2" Vent Version
	60L46	3" Vent Version
2-Stage Compressor Kit	85W66	Blower Relay Kit
Twinning Kit	16W72	Constant Torque Gas Furnace Twinning Kit

Note: For vent length and clearances to combustibles, please reference installation instructions.

Parts Arrangement

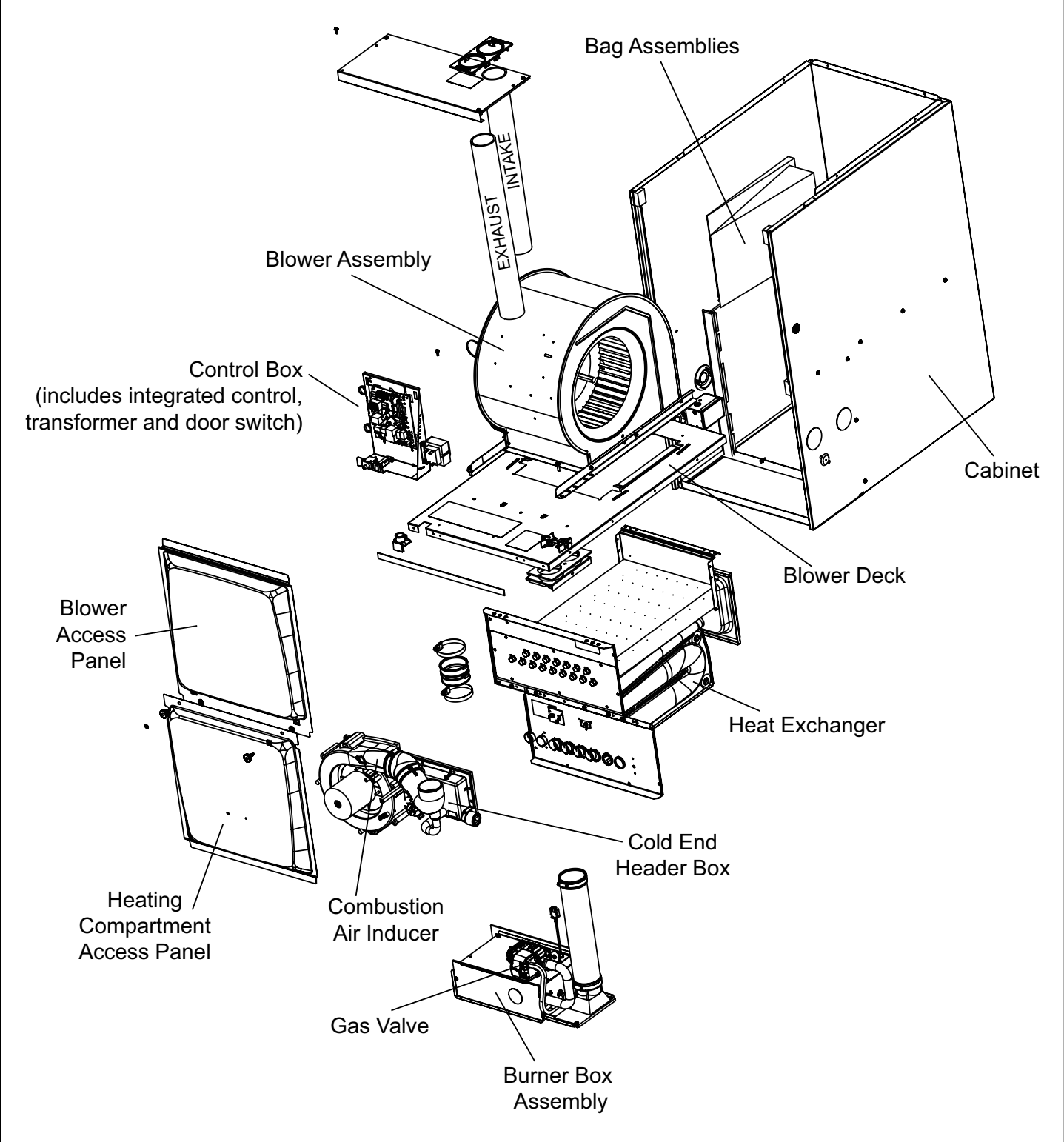

Figure 1.

Electrical

ELECTROSTATIC DISCHARGE (ESD)

Precautions and Procedures

CAUTION

Electrostatic discharge can affect electronic components. Take precautions to neutralize electrostatic charge by touching your hand and tools to metal prior to handling the control.



A93DF1E / 92G1DFE unit components are shown in Figure 1. The combustion air inducer, gas valve and burners can be accessed by removing the outer access panel. The blower and control box can be accessed by removing the blower access panel.

Control Box Components (Figure 2)

Unit transformer (T1) and integrated ignition control (A92) are located in the control box. In addition, a door interlock switch (S51) is located in the control box.

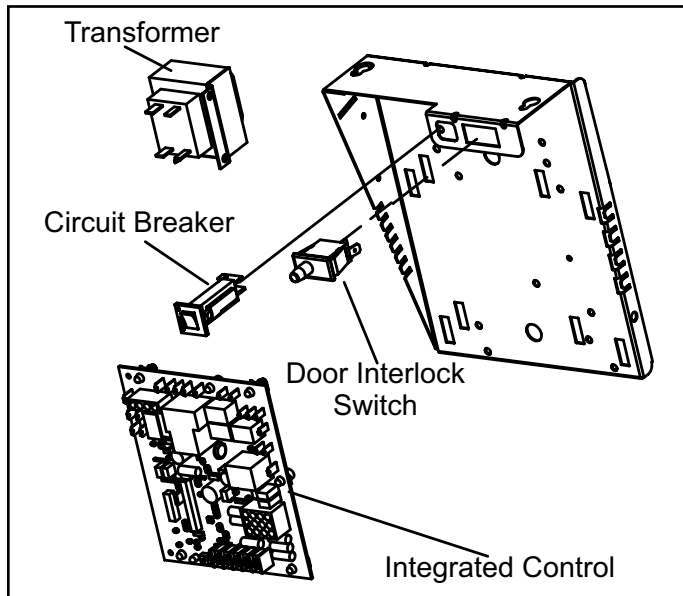

Figure 2. Control Box

Transformer (T1)

A transformer located in the control box provides power to the low voltage section of the unit. The transformers on all models are rated at 40VA with a 120V primary and 24V secondary.

Door Interlock Switch (S51)

A door interlock switch rated 14A at 120VAC is located on the control box. The switch is wired in series with line voltage. When the blower door is removed the unit will shut down.

Circuit Breaker (CB8)

A 24V circuit breaker is also located in the control box. The switch provides overcurrent protection to the transformer (T1). The breaker is rated at 3A at 32V. If the current exceeds this limit the breaker will trip and all unit operation will shutdown. The breaker can be manually reset by pressing the button on the face.

Integrated Ignition Control (A92)

WARNING

Shock hazard.



Disconnect power before servicing. Control is not field repairable. If control is inoperable, simply replace entire control. Can cause injury or death. Unsafe operation will result if repair is attempted.

The hot surface ignition control system consisting of an integrated control (Figure 3 with control terminal designations in Table 1 through Table 3), sensor and ignitor (Figure 5). The integrated control and ignitor work in combination to ensure furnace ignition and ignitor durability. The integrated control, controls all major furnace operations. The integrated control also features a RED LED for troubleshooting and two accessory terminals rated at (1) one amp. See Table 4 or Table 5 for troubleshooting diagnostic codes. The nitride ignitor is made from a non-porous, high strength proprietary ceramic material that provides long life and trouble free maintenance.

Pin #	Function
1	Combustion Air Inducer Line
2	Ignitor Line
3	Combustion Air Inducer Neutral
4	Ignitor Neutral

Table 1. 4-Pin Terminal Designations

Pin #	Function
1	High Limit Output
2	Not Used
3	24V Line
4	Not Used
5	Rollout Switch Out
6	24V Neutral
7	High Limit Input
8	Ground
9	Gas Valve Common
10	Pressure Switch In
11	Rollout Switch In
12	Gas Valve Out

Table 2. 12-Pin Terminal Designations

1/4" Quick Connect Terminals	
120HUM	Humidifier 120VAC
LINE	120VAC
XFMR	Transformer 120VAC
CIRC	Indoor Blower 120VAC
EAC	Indoor Air Quality Accessory 120VAC
NEUTRALS	Common 120VAC
HUM24	Humidifier 24VAC
3/16" Quick Connect Terminals	
COOL	Cooling Tap 24VAC
HEAT	Heating Tap 24VAC
FAN	Continuous Blower 24VAC
PARK (no power)	Park terminal for unused speed taps
FS	Flame Sense
24 COM	Common 24VAC

Table 3.

The integrated control is equipped with an LED light for troubleshooting. The diagnostic codes are listed in Table 4 or Table 5.

Red LED Flash Code ²	Diagnostic Codes / Status of Furnace
Off	No power to control or board fault detected
Heartbeat ¹	Control powered - displayed during all modes of operation if no errors are detected
1	Reverse Line Voltage Polarity
2	Improper Earth Ground
3	Burner failed to light, or lost flame during heat demand
4	Low Flame Signal - check flame sensor
5	Watchguard - burner failed to light, exceeded maximum number of retries or recycles
6	Not Used
7	Primary or Secondary Limit Open or Watchguard Mode - Limit Switch Open longer than 3 minutes
8	Rollout Switch Open
9	Pressure Switch failed to close or opened during heat demand
10	Watchguard - Pressure Switch opened 5 times during one heat demand
11	Pressure Switch stuck closed prior to activation of combustion air inducer
12	Flame Sensed without gas valve energized
13	Low Line Voltage
<p>1 A "Heartbeat" is indicated by a "Slow Flash" - 1 sec on 1 sec off, repeating</p> <p>2 Error codes are indicated by a "Rapid Flash" - the LED flashes X times at 1/2 sec on 1/2 sec off, remains off for 3 sec, then repeats</p> <p>NOTE: Last 10 error codes are stored in memory including when power is shut off to the unit. - To recall, press and release button, most recent will be displayed first, LED off for 3 sec, then next error code is displayed, etc. To clear error codes, depress and hold button longer than 5 seconds.</p>	

Table 4. -02 Control Diagnostic Codes

Red LED Flash Code ²	Diagnostic Codes / Status of Furnace
Off	No power to control or board fault detected
Heartbeat ¹	Normal Operation - Idle, Continuous Fan, Cool
Continuous Rapid Flash	Call for Heat / Burner Operation
1	Reverse Line Voltage Polarity
2	Improper Earth Ground
3	Burner failed to light, or lost flame during heat demand
4	Low Flame Signal - check flame sensor
5	Watchguard - burner failed to light, exceeded maximum number of retries or recycles
6	Not Used
7	Primary or Secondary Limit Open or Watchguard Mode - Limit Switch Open longer than 3 minutes
8	Rollout Switch Open
9	Pressure Switch failed to close or opened during heat demand
10	Watchguard - Pressure Switch opened 5 times during one heat demand
11	Pressure Switch stuck closed prior to activation of combustion air inducer
12	Flame Sensed without gas valve energized
13	Low Line Voltage
<p>1 A "Heartbeat" is indicated by a "Slow Flash" - 1 sec on 1 sec off, repeating</p> <p>2 Error codes are indicated by a "Rapid Flash" - the LED flashes X times at 1/2 sec on 1/2 sec off, remains off for 3 sec, then repeats</p> <p>NOTE: Last 10 error codes are stored in memory including when power is shut off to the unit. - To recall, press and release button, most recent will be displayed first, LED off for 3 sec, then next error code is displayed, etc. To clear error codes, depress and hold button longer than 5 seconds.</p>	

Table 5. -03 Control Diagnostic Codes

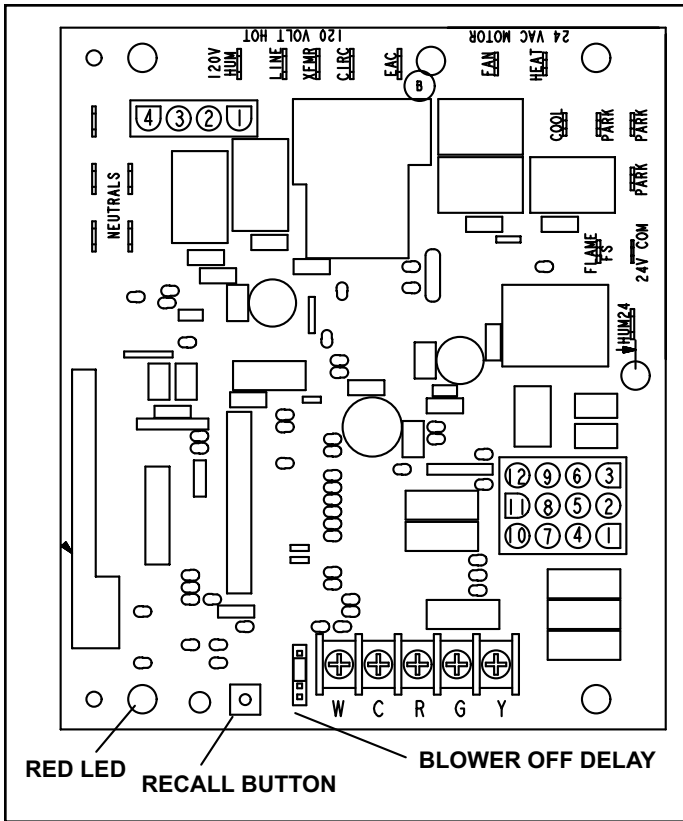

**Figure 3. Integrated Control
(Automatic Hot Surface Ignition System)**

Electronic Ignition

On a call for heat the integrated control monitors the combustion air inducer pressure switch. The control board will not begin the heating cycle if the pressure switch is closed (by-passed). Once the pressure switch is determined to be open, the combustion air inducer is energized. When the differential in the pressure switch is great enough, the pressure switch closes and a 15-second pre-purge begins. If the pressure switch is not proven within 2-1/2 minutes, the integrated control goes into Watchguard-Pressure Switch mode for a 5-minute re-set period.

After the 15-second pre-purge period, the ignitor warms up for 20 seconds during which the gas valve opens at 19 seconds for a 4-second trial for ignition. The ignitor remains energized for the first 3 seconds during the 4 second trial. If ignition is not proved during the 4-second period, the integrated control will try four more times with an inter purge and warm-up time between trials of 35 seconds. After a total of five trials for ignition (including the initial trial), the integrated control goes into Watchguard-Flame Failure mode. After a 60-minute reset period, the integrated control will begin the ignition sequence again.

Fan Time Control

Heating Fan On Time

The fan on time of 30 seconds is not adjustable.

Heating Fan Off Time

Fan off time (time that the blower operates after the heat demand has been satisfied) can be adjusted by moving the jumper to a different setting. The unit is shipped with a factory fan off setting of 90 seconds. For customized comfort, monitor the supply air temperature once the heat demand is satisfied. Note the supply air temperature at the instant the blower is de-energized.

Adjust the fan-off delay to achieve a supply air temperature between 90° - 110° at the instant the blower is de-energized.

(Longer delay times allow for lower air temperature, shorter delay times allow for higher air temperature). See Figure 4.

Cooling Fan On Time

The fan on time is 2 seconds and is not adjustable.

Cooling Fan Off Time

The control has a 45 second fan off delay after cooling demand has been met. This delay is factory set and not adjustable.

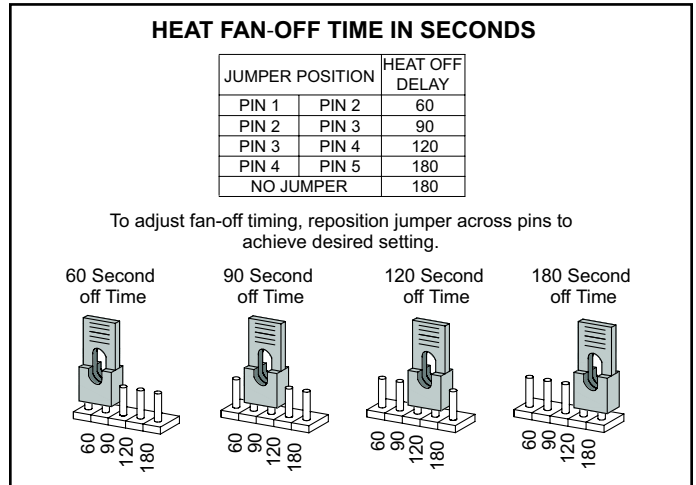

Figure 4.

Heating Components

Combustion air inducer (B6), primary limit control (S10), ignitor, burners, flame rollout switch (S47), gas valve (GV1), combustion air pressure switch (S18), and heat exchangers are located in the heating compartment. The heating compartment can be accessed by removing the outer access panel.

Ignitor (Figure 5)

A93DF1E / 92G1DFE units use a nitride ignitor made from a proprietary ceramic material. To check ignitor, measure its resistance and voltage. A value of 39 to 70 ohms indicates a good ignitor. Voltage to the ignitor should be 102 - 132VAC. See Figure 9 for resistance and voltage checks.

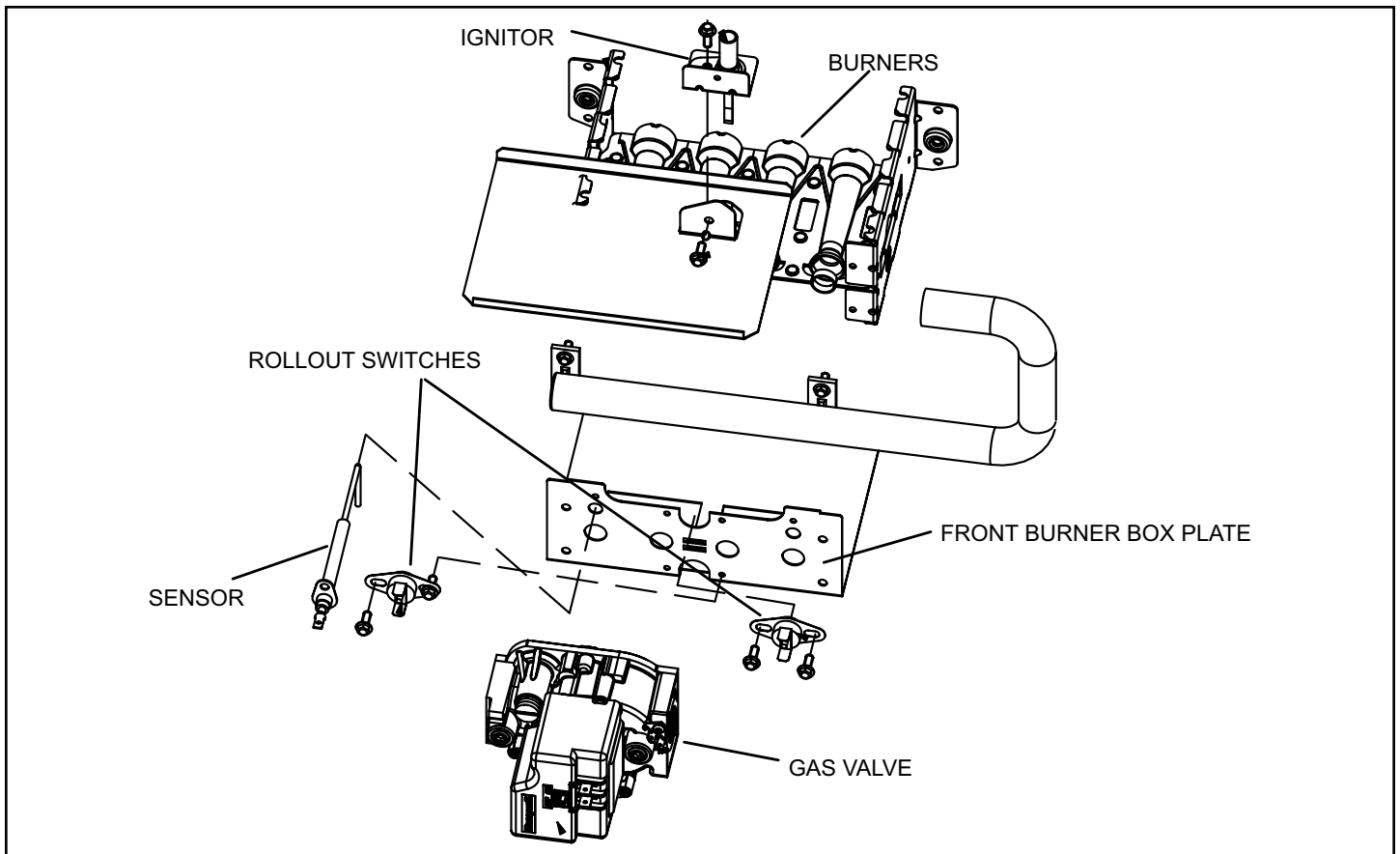

Figure 5. Burner Box Assembly

Flame Rollout Switches (Figure 5)

Flame rollout switches S47 are SPST N.C. high temperature limits located on the left and right of the front burner box plate. S47 is wired to the burner ignition control A92. When either of the switches sense flame rollout (indicating a blockage in the combustion passages), the flame rollout switch trips, and the ignition control immediately closes the gas valve. Switch S47 in all A93DF1E / 92G1DFE units is factory preset to open at 210F + 12F (99C + 6.7C) on a temperature rise. All flame rollout switches are manual reset. See flash code 8 in Table 4 or Table 5 for troubleshooting.

Flame Sensor (Figure 5)

A flame sensor is located on the left side of the burner support. The sensor is mounted on the front burner box plate and the tip protrudes into the flame envelope of the leftmost burner. The sensor can be removed for service (use steel wool only to clean) without removing any part of the burners. During operation, flame is sensed by current passed through the flame and sensing electrode. The ignition control allows the gas valve to remain open as long as flame signal is sensed.

NOTE: *The A93DF1E / 92G1DFE is polarity sensitive. Make sure that the furnace is wired correctly and is properly grounded.*

A microamp DC meter is needed to check the flame signal on the integrated control.

Flame (microamp) signal is an electrical current which passes from the integrated control to the sensor during unit operation. Current passes from the sensor through the flame to ground to complete a safety circuit.

Heat Exchanger (Figure 6)

A93DF1E / 92G1DFE units use an aluminized steel primary and stainless steel secondary heat exchanger assembly. Heat is transferred to the air stream from all surfaces of the heat exchanger. The shape of the heat exchanger ensures maximum efficiency.

The combustion air inducer pulls fresh air through the burner box. This air is mixed with gas in the burners. The gas / air mixture is then burned at the entrance of each clamshell. Combustion gases are then pulled through the primary and secondary heat exchangers and exhausted out the exhaust vent pipe.

Primary Limit Control (Figure 6)

Primary limit (S10) used on A93DF1E / 92G1DFE units is located in the heating vestibule panel. When excess heat is sensed in the heat exchanger, the limit will open. Once the limit opens, the furnace control energizes the supply air blower and de-energizes the gas valve. The limit automatically resets when unit temperature returns to normal. The switch is factory set and cannot be adjusted. For limit replacement remove wires from limit terminals, remove mounting screws, rotate limit switch 90 degrees and slowly remove from the vestibule panel. Install replacement limit with same care. See flash code 7 in Table 4 or Table 5 for troubleshooting if limit switch opens during operation.

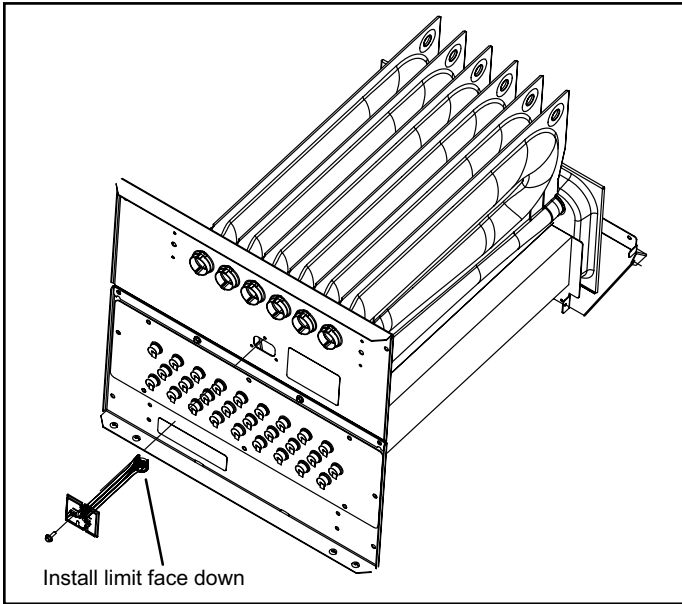

Figure 6. Primary Limit Location and Heat Exchanger

Gas Valve (Figure 7)

The A93DF1E / 92G1DFE uses an internally redundant valve to assure safety shut-off. If the gas valve must be replaced, the same type valve must be used.

24VAC terminals and gas control switch are located on top of the valve. All terminals on the gas valve are connected to wires from the ignition control. 24V applied to the terminals opens the valve.

Inlet and outlet pressure taps are located on the valve. A manifold adjustment screw is also located on the valve. An LP/Propane changeover kit is available.

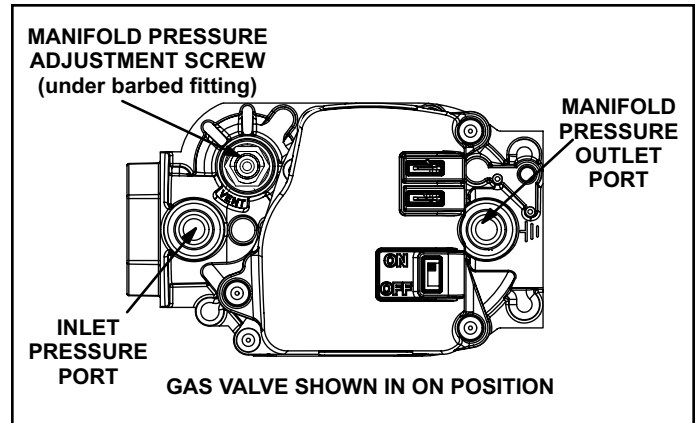

Figure 7. Gas Valve

To Measure Flame Signal - Integrated Control:

Use a digital readout meter capable of reading DC microamps. See Figure 8 for flame signal check.

1. Set the meter to the DC amps scale.
2. Turn off supply voltage to control.
3. Remove sensor wire from integrated control.
4. Connect (-) lead to flame sensor wire.
5. Connect (+) lead to Terminal FS on integrated control.
6. Turn supply voltage on and close thermostat contacts to cycle system.
7. When main burners are in operation for two minutes, take reading.

Flame Signal In Microamps

Normal	Low	Drop Out
≥ 1.5	0.5 - 1.4	≤ 0.4

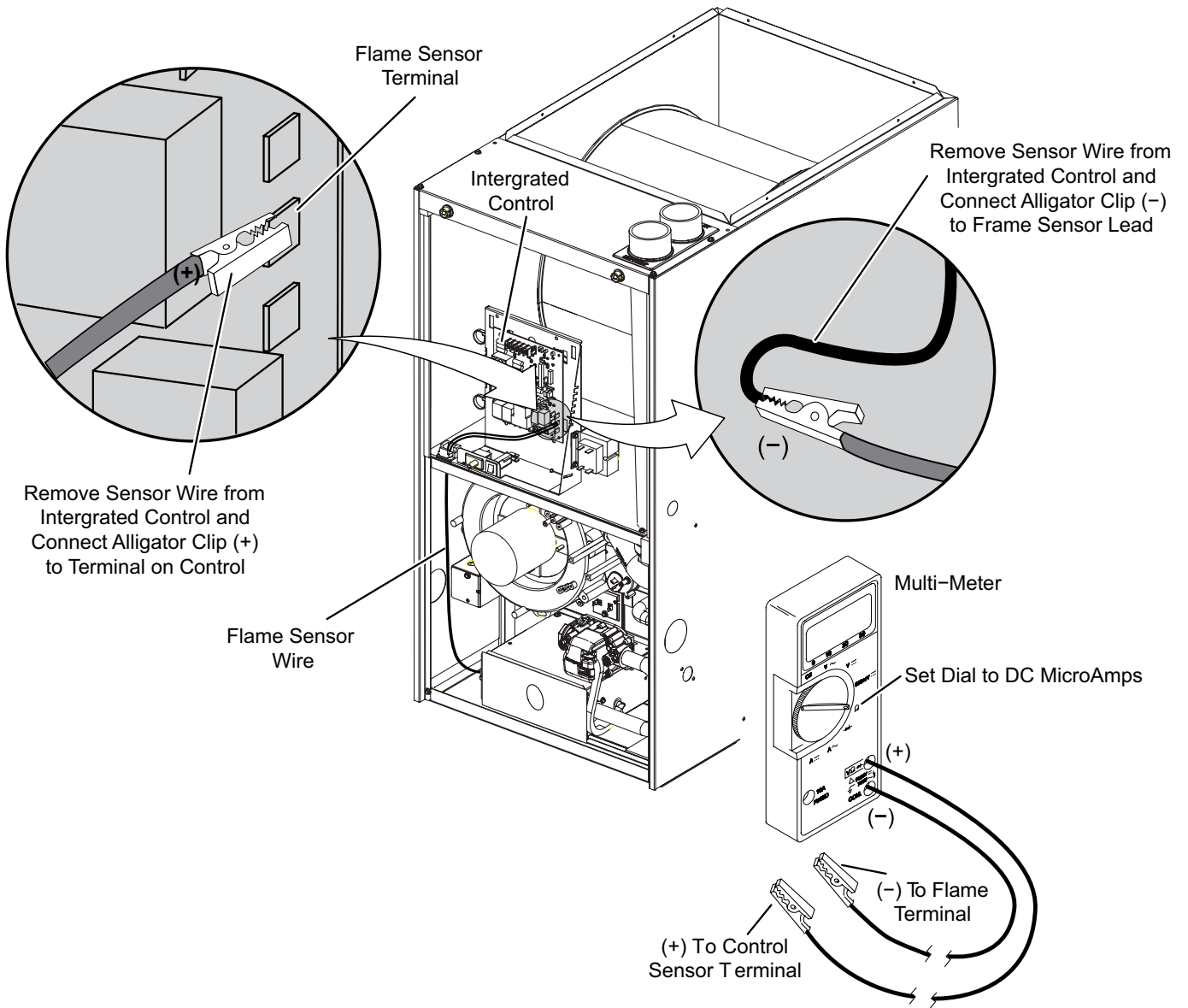
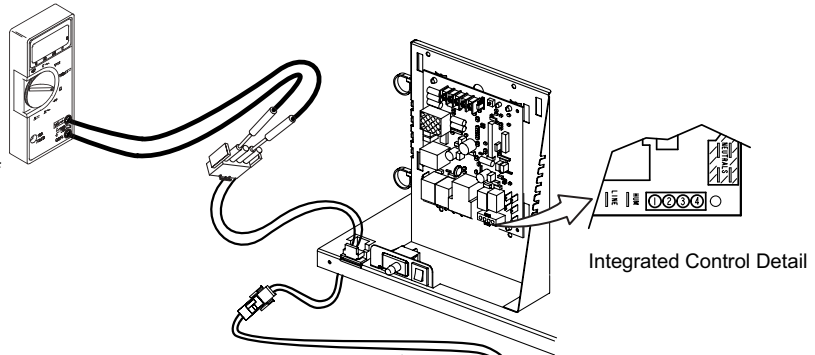

Figure 8. Measuring Flame Signal

Test 1
Check ignitor circuit for correct resistance.

Remove 4-pin plug from control.
Check ohms reading across terminals 2 and 4.
Reading should be between 39 and 70 ohms. If
value is correct, this is the only test needed.
If the reading on the meter is not correct, (0 or
infinity) then a second test is needed.



Test 2
Check ignitor for correct resistance.

Separate the 2-pin jack-plug near the manifold
and check resistance of ignitor at the plug.
Reading should be between 39 and 70 ohms. If
the reading is correct, then the problem is with
the wiring between the jack-plug and the control.
If reading is not correct, the issue is the ignitor.

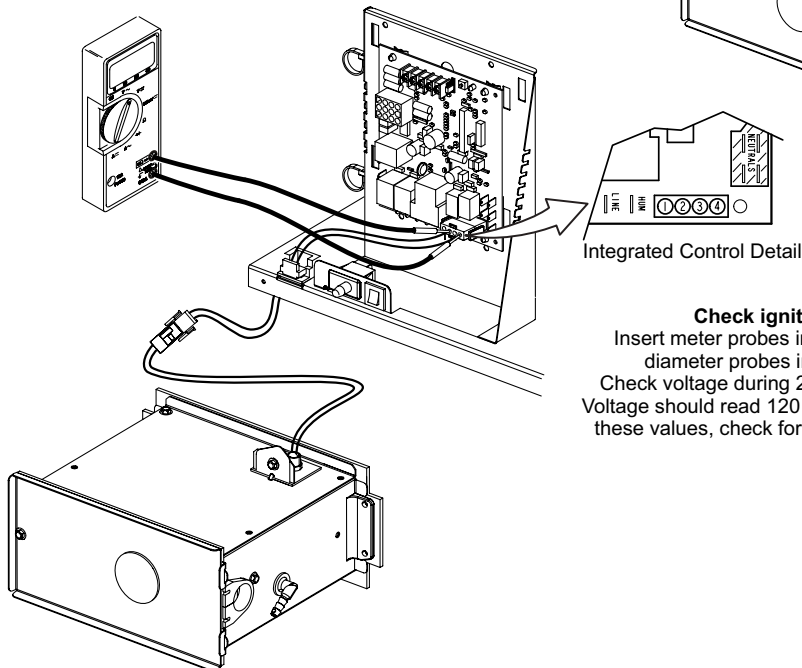
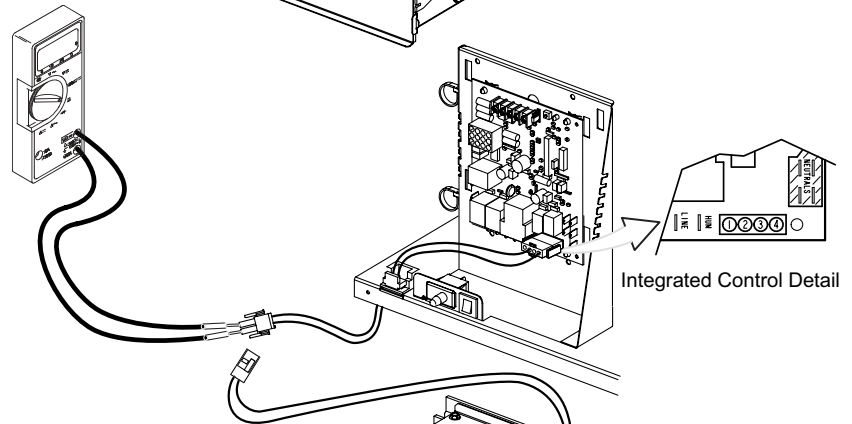

Test 3
Check ignitor for correct voltage

Insert meter probes into terminals 2 and 4 (use small
diameter probes in order not to damage plug).
Check voltage during 20 second ignitor warm up period.
Voltage should read 120 volts \pm 10%. If voltage reads below
these values, check for correct supply voltage to furnace.

Figure 9.

Combustion Air Inducer (B6) & Cold End Header Box

All A93DF1E / 92G1DFE units use a combustion air inducer to move air through the burners and heat exchanger during heating operation. The blower uses a shaded pole 120VAC motor. The motor operates during all heating operation and is controlled by integrated control A92. Blower operates continuously while there is a call for heat. The integrated control will not proceed with the ignition sequence until combustion air inducer operation is sensed by the proving switches.

The combustion air inducer is installed on the cold end header box. The cold end header box is a single piece made of hard plastic. The box has an internal channel where the combustion air inducer creates negative pressure at unit start up. The channel contains an orifice used to regulate flow created by the combustion air inducer. The box has pressure taps for the combustion air inducer pressure switch hoses. The pressure switch measures the pressure across the combustion air inducer orifice or difference in the channel and the box. If replacement is necessary the gaskets used to seal the box to the vestibule panel and the combustion air inducer to the box, must also be replaced.

Combustion Air Pressure Switch (Figure 10)

A93DF1E / 92G1DFE series units are equipped with a differential pressure switch located on the cold end header box. The switch monitors across the combustion air inducer orifice to insure proper flow through the heat exchanger.

The switch is a SPST N.O. pressure switch electrically connected to the integrated control. The purpose of the switch is to prevent burner operation if the combustion air inducer is not moving enough air for proper combustion.

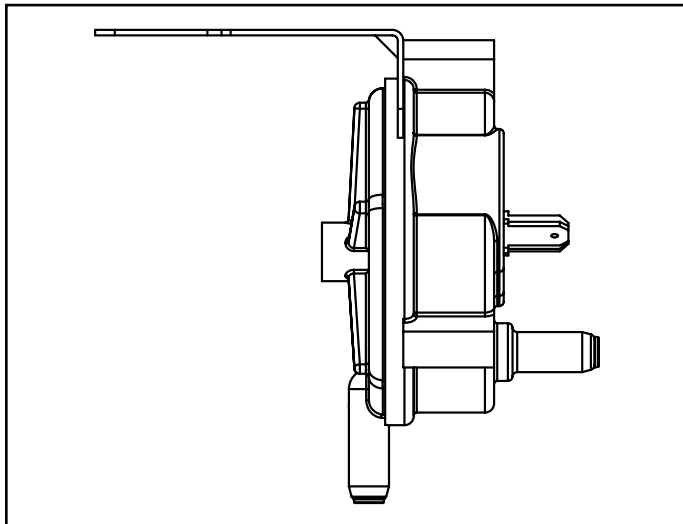

Figure 10. Pressure Switch

On start-up, the switch monitors whether the combustion air inducer is operating. It closes a circuit to the integrated control when the difference in pressure across the combustion air inducer orifice exceeds a non-adjustable factory setting. If the switch does not successfully sense the required differential, the switch cannot close and the furnace cannot operate. If the flue or air inlet become obstructed during operation, the switch senses a loss of pressure differential and opens the circuit to the integrated control. If the condensate line is blocked, water will back up into the header box and reduce the pressure differential across the switch. The pressure switch opens if the differential drops below the set point. See Table 6.

Checks of pressure differential can aid in troubleshooting. When measuring the pressure differential, readings should be taken at the pressure switch. See Figure 11 and Table 7. Lack of differential usually indicates problems in the intake or exhaust piping, but may indicate problems in the heat exchanger, condensing coil, header boxes, combustion inducer or other components.

Unit	Altitude (ft.)
	0 - 4500
	Set Point "w.c.
045	-0.65"
070	-0.65"
090	-0.65"

NOTE: Set point is factory set and non-adjustable

Table 6.

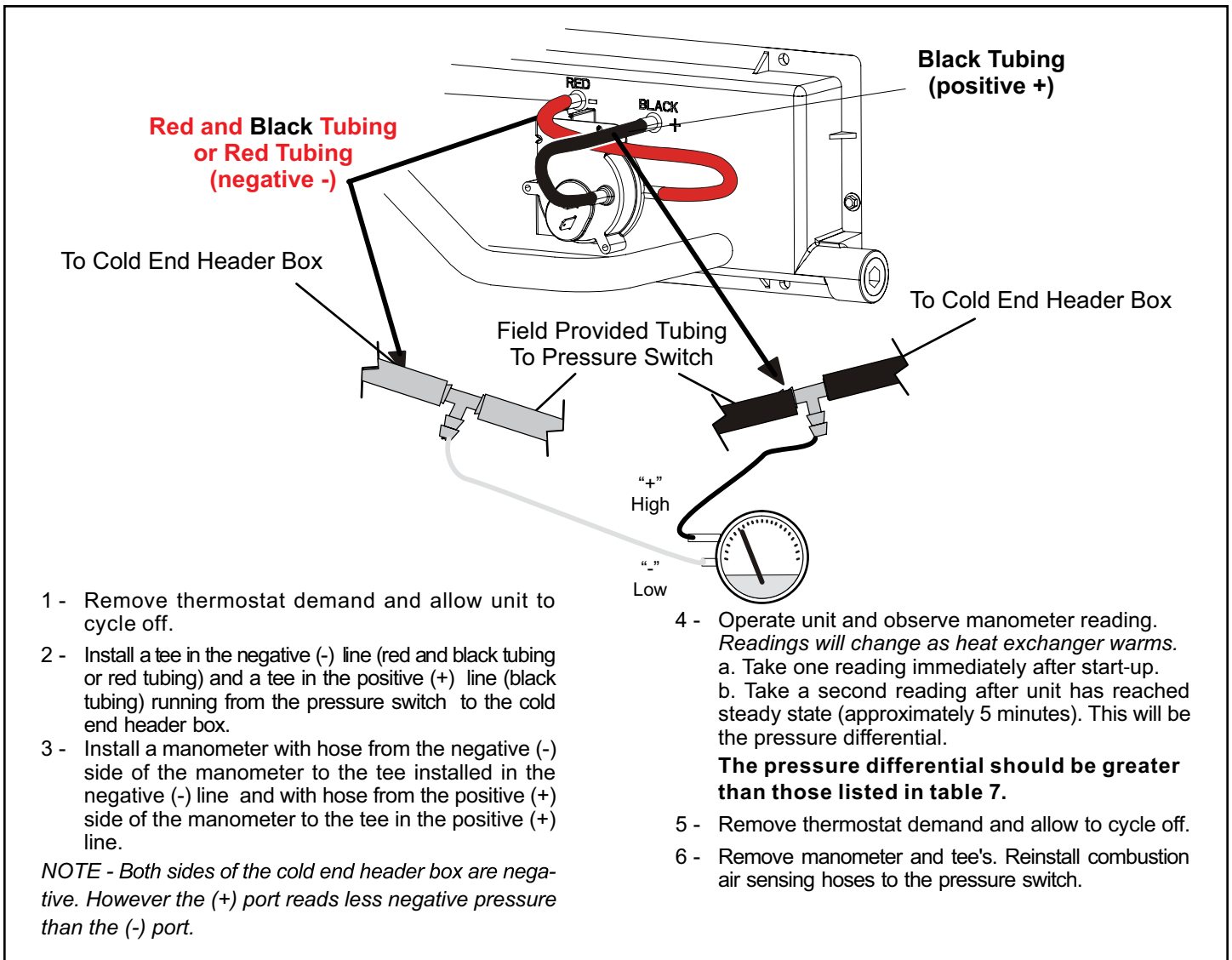

Figure 11. Measuring Pressure Differential

Problem	Corrective Action
Pressure switch stuck closed	Check that the pressure switch is open without the combustion air inducer operating. Replace if defective.
Pressure switch does not close due to obstruction in vent pipe	Check for restricted vent. Remove all blockage. Check for proper vent sizing. See Table 11A through Table 11B.
Pressure switch does not close due to incorrect routing of the pressure switch tubing	Check that the pressure switch tubing is correctly routed. Correctly route pressure switch line.
Pressure switch does not close due to obstructions in the pressure switch line	Remove any obstructions from the the pressure switch line and/or taps
Pressure switch tubing damaged	Check pressure switch tubing for leaks. Replace damaged tubing if necessary.
Condensate in pressure switch tubing	Check pressure switch tubing for condensate. Remove condensate from tubing.
Pressure switch does not close due to a low differential pressure across the pressure switch	Check the differential pressure across the pressure switch. Check for restricted inlet vent. Remove all blockage. Check for proper vent sizing and run length. See Table 11A through Table 11B.
Wrong pressure switch installed in the unit, or pressure switch is out of calibration	Check that the correct pressure switch is installed in the unit. Replace pressure switch if necessary.
Miswiring of furnace or improper connections at pressure switch	Check for correct wiring and loose connections. Correct wiring and/or replace any loose connections.
Pressure switch failure	If all the above modes of failure have been checked, the pressure switch may have failed. Replace pressure switch and determine if unit will operate.
Damaged condensate trap	Check trap for any cracks or damage and replace if necessary.
Cold end header box does not drain properly	Check that the furnace is set properly with a slight tilt (0 - 1/2") towards the front if necessary. See furnace installation instruction.
Air leakage around the combustion air inducer gasket	Check gasket and replace if necessary.
Air leakage around the cold end header box gasket	Check gasket and replace if necessary.
Damaged cold end header box tubing	Check tubing and replace if necessary.

Table 7. Pressure Switch Troubleshooting Guide

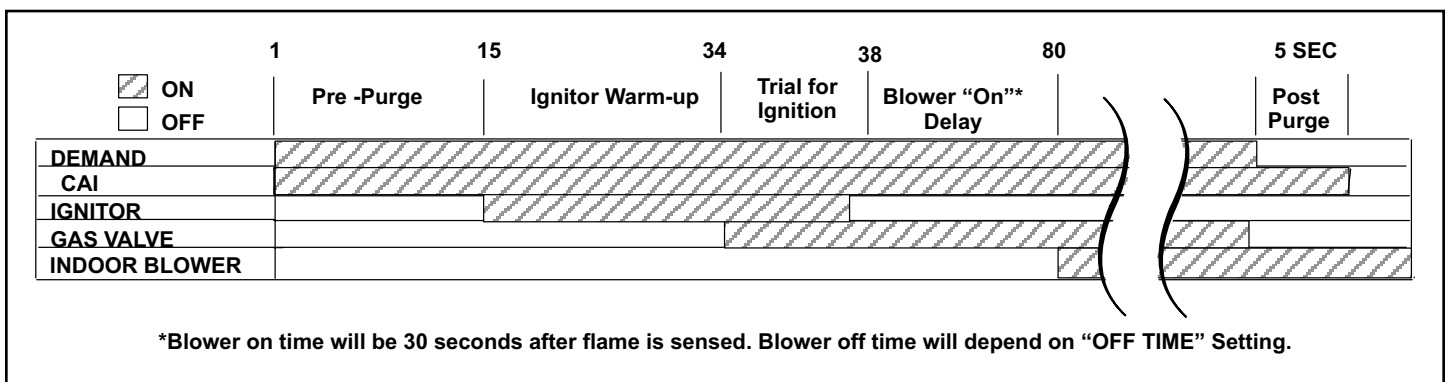

Figure 12. Electronic Ignition

Blower Compartment

⚠ IMPORTANT

Each blower is statically and dynamically balanced as an assembly before installation in the unit.

A93DF1E / 92G1DFE units are equipped with a constant torque ECM motor. It has a DC motor coupled to an electronic control module both contained in the same motor housing. The motor is programmed to provide constant torque at each of the five selectable speed taps. Each tap requires 24 volts to energize.

Input Voltage Requirements

The circuit is designed to be operated with AC voltage. To enable a tap requires 12 to 33VAC. Expected current draw will be less than 20mA.

Troubleshooting the Motor

Troubleshooting the motor is an easy process. Follow steps below.

1. Shut off power to unit.
2. Remove input plugs P48 and P49 from motor. See Figure 16 for troubleshooting procedure.

If correct voltage is present in tests 1 and 2 and motor is not operating properly, replace motor. The motor is not field repairable.

If replacing the indoor blower motor or blower wheel is necessary, placement is critical. The blower wheel must be centered in the blower housing as shown in Figure 13. When replacing the indoor blower motor the set screw must be aligned and tightened with the motor shaft as shown in Figure 14.

Secondary Limit Controls

The secondary limit is located in the blower compartment on the back side of the blower housing. See Figure 15. When excess heat is sensed in the blower compartment, the limit will open. If the limit is open, the furnace control energizes the supply air blower and closes the gas valve. The limit automatically resets when unit temperature returns to normal. The secondary limit cannot be adjusted.

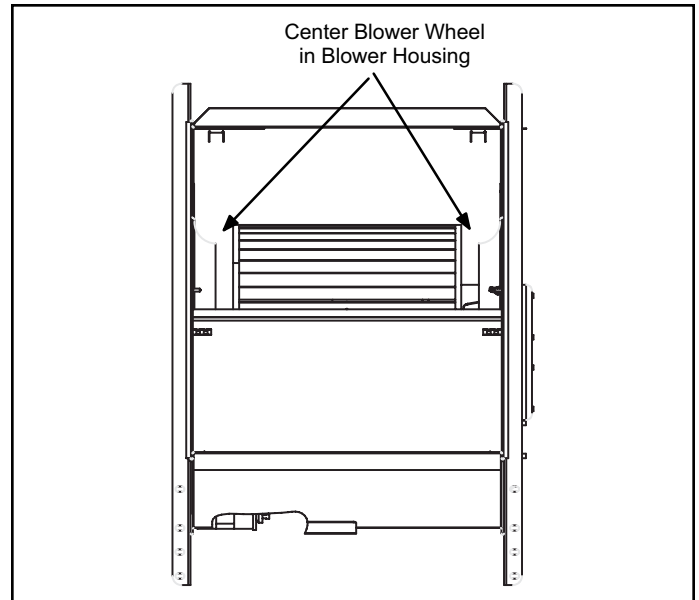

Figure 13. Blower Wheel Replacement

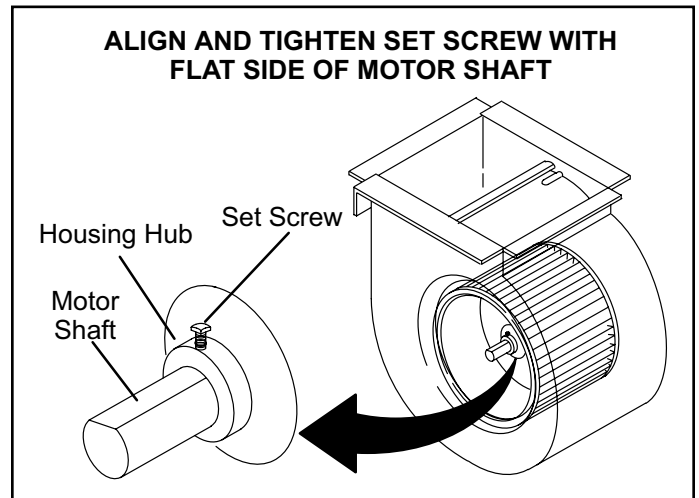

Figure 14.

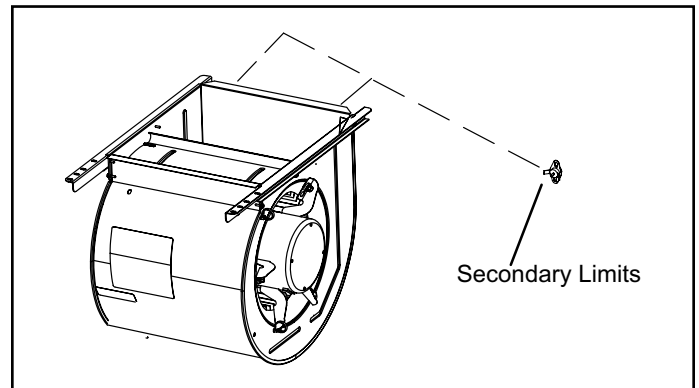
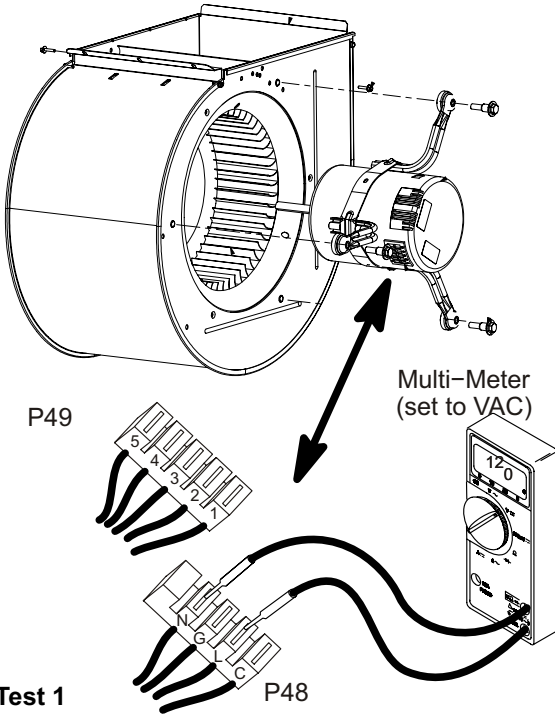
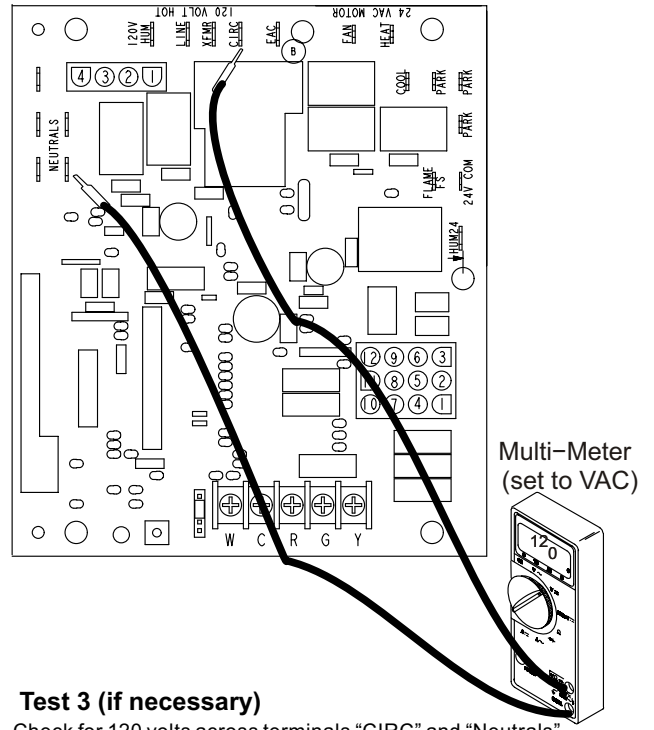

Figure 15. Secondary Limit Control



Test 1
 Turn on power to unit. Check for 120 volts across terminals "L" and "N" on input plug P48. If voltage is present continue to test 2. If voltage is not present, problem may be upstream of plug P48. Proceed to test 3.



Test 3 (if necessary)
 Check for 120 volts across terminals "CIRC" and "Neutrals" on the integrated control. If voltage is present, problem is with the harness. If voltage is not present problem may be with the integrated control.

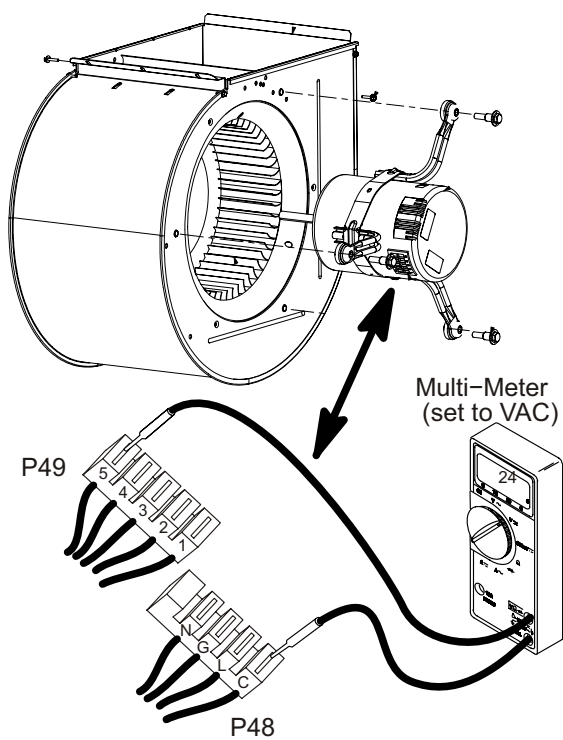

Test 2
 Switch thermostat to CONTINUOUS FAN MODE. Check for 24 volts across terminal "C" on input plug P48 and speed tap used for continuous fan. (1, 2, 3, 4 or 5) on input plug P49. If 24 volts is not present problem may be up stream of plug P49. Proceed to test 4.

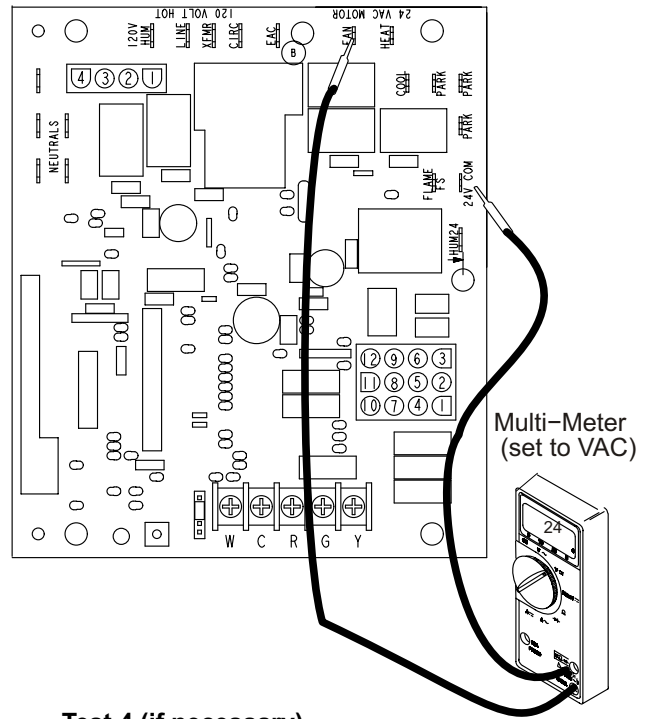

Test 4 (if necessary)
 Check for 24 volts across terminals "24 COM" and "FAN" terminals on the integrated control. If voltage is present, problem is with the harness. If voltage is not present, problem may be with the integrated control.

Figure 16.

Testing the Motor (Figure 17)

If any motor fails the below tests, do not install the new control module. The motor is defective and it also must be replaced. The new control can fail if placed on a defective motor.

1. Using an ohmmeter check the resistance from any one of the motor connector pins to the aluminum end plate of the motor. This resistance should be greater than 100k ohms.
2. Check the resistances between each of the three motor connector pins. These should all read approximately the same resistance within an ohm.
3. Check to see if the blower wheel spins freely.



Figure 17. Motor Test

Scale	Measurement Range in Words	ohms
2 M	two megohms - two million ohms	0 - 2,000,000
200 K	two hundred kil-ohms - two hundred thousand ohms	0 - 200,000
20 K	twenty kilo-ohms - twenty thousand ohms	0 - 20,000
2 K	two kilo-ohms - two-thousand ohms	0 - 2,000
200	two hundred ohms	0 - 200

Motor Module Installation

All replacement motor control modules look similar; however, each module is designed for a specific motor size. It is very important to make sure that you are using the correct replacement motor control module. **USE OF THE WRONG MOTOR CONTROL MODULE MAY RESULT IN UNEXPECTED UNIT OPERATION.**

1. Verify electrical power to unit is disconnected.
2. Connect three-wire harness from motor to control module.
3. Mount new motor control module to motor using two hex head bolts. Torque bolts to 22 inch pounds or 1/16th clock turn as exemplified to the right.
4. Reconnect the two harnesses to the motor control module.
5. The electrical connectors of the motor should be facing down to form a drip loop (Figure 18). This will direct moisture away from the motor and its electric connections on the motor.

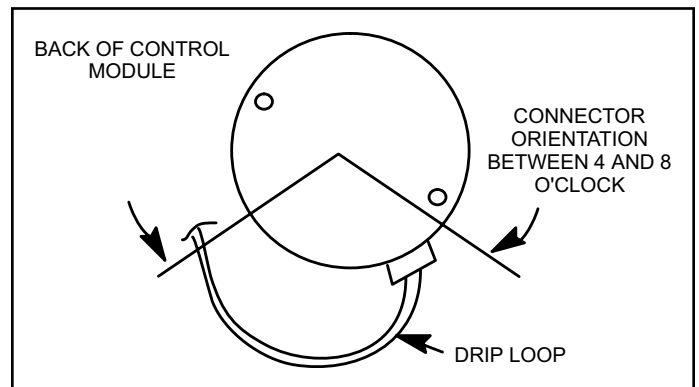
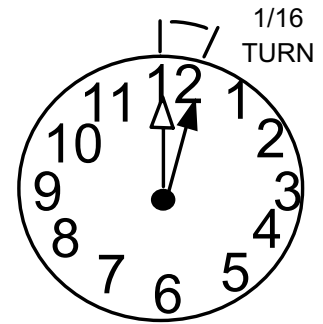

Figure 18. Drip Loop

Placement & Installation

Pipe & Fittings Specifications

All pipe, fittings, primer and solvent cement must conform with American National Standard Institute and the American Society for Testing and Materials (ANSI/ASTM) standards. The solvent shall be free flowing and contain no lumps, undissolved particles or any foreign matter that adversely affects the joint strength or chemical resistance of the cement. The cement shall show no gelation, stratification, or separation that cannot be removed by stirring. Refer to Table 8 for approved piping and fitting materials.

CAUTION

Solvent cements for plastic pipe are flammable liquids and should be kept away from all sources of ignition. Do not use excessive amounts of solvent cement when making joints. Good ventilation should be maintained to reduce fire hazard and to minimize breathing of solvent vapors. Avoid contact of cement with skin and eyes.

IMPORTANT

A93DF1E / 92G1DFE exhaust and intake connections are made of PVC. Use PVC primer and solvent cement when using PVC vent pipe. When using ABS vent pipe, use transitional solvent cement to make connections to the PVC fittings in the unit.

Use PVC primer and solvent cement or ABS solvent cement meeting ASTM specifications, refer to Table 8. As an alternate, use all purpose cement, to bond ABS, PVC, or CPVC pipe when using fittings and pipe made of the same materials. Use transition solvent cement when bonding ABS to either PVC or CPVC.

Low temperature solvent cement is recommended during cooler weather. Metal or plastic strapping may be used for vent pipe hangers. Uniformly apply a liberal coat of PVC primer for PVC or use a clean dry cloth for ABS to clean inside socket surface of fitting and male end of pipe to depth of fitting socket.

NOTE: Canadian Applications Only - Pipe, fittings, primer and solvent cement used to vent (exhaust) this appliance must be certified to ULC S636 and supplied by a single manufacturer as part of an approved vent (exhaust) system. In addition, the first three feet of vent pipe from the furnace flue collar must be accessible for inspection.

Piping and Fittings Specifications

Schedule 40 PVC (Pipe)	D1785
Schedule 40 PVC (Cellular Core Pipe)	F891
Schedule 40 PVC (Fittings)	D2466
Schedule 40 CPVC (Pipe)	F441
Schedule 40 CPVC (Fittings)	F438
SDR-21 PVC or SDR-26 PVC (Pipe)	D2241
SDR-21 CPVC or SDR-26 CPVC (Pipe)	F442
Schedule 40 ABS Cellular Core DWV (Pipe)	F628
Schedule 40 ABS (Pipe)	D1527
Schedule 40 ABS (Fittings)	D2468
ABS-DWV (Drain Waste & Vent) (Pipe & Fittings)	D2661
PVC-DWV (Drain Waste & Vent) Pipe & Fittings)	D2665
PRIMER & SOLVENT CEMENT	ASTM SPECIFICATION
PVC & CPVC Primer	F656
PVC Solvent Cement	D2564
CPVC Solvent Cement	F493
ABS Solvent Cement	D2235
PVC/CPVC/ABS All Purpose Cement For Fittings & Pipe of the same material	D2564, D2235, F493
ABS to PVC or CPVC Transition Solvent Cement	D3138
CANADA PIPE & FITTING & SOLVENT CEMENT	MARKING
PVC & CPVC Pipe and Fittings	ULCS636
PVC & CPVC Solvent Cement	
ABS to PVC or CPVC Transition Cement	
POLYPROPYLENE VENTING SYSTEM	ULC-S636
PolyPro® by Duravent	
InnoFlue® by Centrotherm	
ECCO Polypropylene Vent™	

Table 8.

Capacity	VENT PIPE DIA. (in.)	STANDARD			CONCENTRIC		
		Outdoor Exhaust Accelerator (Dia. X Length)	Outdoor Exhaust Accelerator (Dia. X Length)	Flush Mount Kit	1-1/2" Concentric Kit	2" Concentric Kit	3" Concentric Kit
		1-1/2" X 12"	2" X 12"	51W11 **	71M80 or +44W92++	69M29 or +44W92++	60L46 or 44W93+
045	1-1/2			YES	YES		
	2	YES		YES	YES		
	2-1/2	YES		YES	YES		
	3	YES		YES	YES		
070	1-1/2	YES		YES	YES		
	2	YES		YES	YES		
	2-1/2	YES		YES	YES		
	3	YES		YES	YES		
090	2			YES		YES	YES
	2-1/2		YES	YES		YES	YES
	3		YES	YES		YES	YES

** Kit 51W11 is provided with a 1-1/2" accelerator which must be for all 2 and 2-1/2" PVC installations.
+ Termination kits 44W92 and 44W93 are approved for use in Canadian installations to meet CSAB149.
++ The 44W92 Concentric kit is provided with a 1-1/2" accelerator, which must be installed on the exhaust outlet when this kit is used with this furnace.
NOTE: When using 1-1/2" piping and terminating with a flush mount kit or concentric kit, the pipe must be transitioned to 2" pipe before attaching to the flush mount kit or the concentric kit.

Table 9. Outdoor Termination Kits Usage

Joint Cementing Procedure

All cementing of joints should be done according to the specifications outlined in ASTM D 2855.

NOTE: A sheet metal screw may be used to secure the intake pipe to the connector, if desired. Use a drill or self tapping screw to make a pilot hole.



DANGER

DANGER OF EXPLOSION!

Fumes from PVC glue may ignite during system check. Allow fumes to dissipate for at least 5 minutes before placing unit into operation.

1. Measure and cut vent pipe to desired length.
2. Deburr and chamfer end of pipe, removing any ridges or rough edges. If end is not chamfered, edge of pipe may remove cement from fitting socket and result in a leaking joint.

NOTE: Check the inside of vent pipe thoroughly for any obstruction that may alter furnace operation.

3. Clean and dry surfaces to be joined.
4. Test fit joint and mark depth of fitting on outside of pipe.
5. Uniformly apply a liberal coat of PVC primer for PVC or use a clean dry cloth for ABS to clean inside socket surface of fitting and male end of pipe to depth of fitting socket.
NOTE: Time is critical at this stage. Do not allow primer to dry before applying cement.
6. Promptly apply solvent cement to end of pipe and inside socket surface of fitting. Cement should be applied lightly but uniformly to inside of socket. Take care to keep excess cement out of socket. Apply second coat to end of pipe.
7. Immediately after applying last coat of cement to pipe, and while both inside socket surface and end of pipe are wet with cement, forcefully insert end of pipe into socket until it bottoms out. Turn PVC pipe 1/4 turn during assembly (but not after pipe is fully inserted) to distribute cement evenly. DO NOT turn ABS or cellular core pipe.

NOTE: Assembly should be completed within 20

seconds after last application of cement. Hammer blows should not be used when inserting pipe.

8. After assembly, wipe excess cement from pipe at end of fitting socket. A properly made joint will show a bead around its entire perimeter. Any gaps may indicate an improper assembly due to insufficient solvent.
9. Handle joints carefully until completely set.

Venting Practices

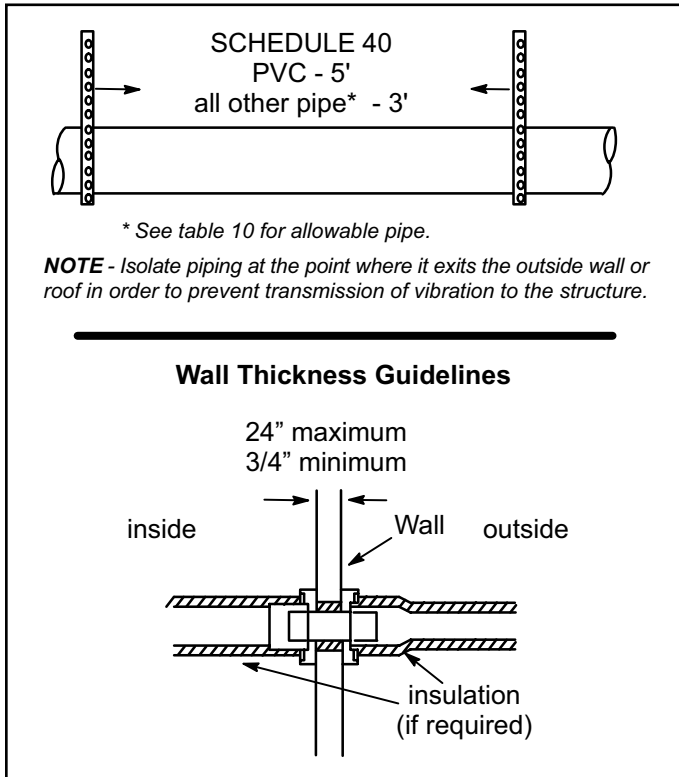

Figure 19. Piping Suspension Guidelines

- In areas where piping penetrates joists or interior walls, hole must be large enough to allow clearance on all sides of pipe through center of hole using a hanger.
- When furnace is installed in a residence where unit is shut down for an extended period of time, such as a vacation home, make provisions for draining condensate collection trap and lines.

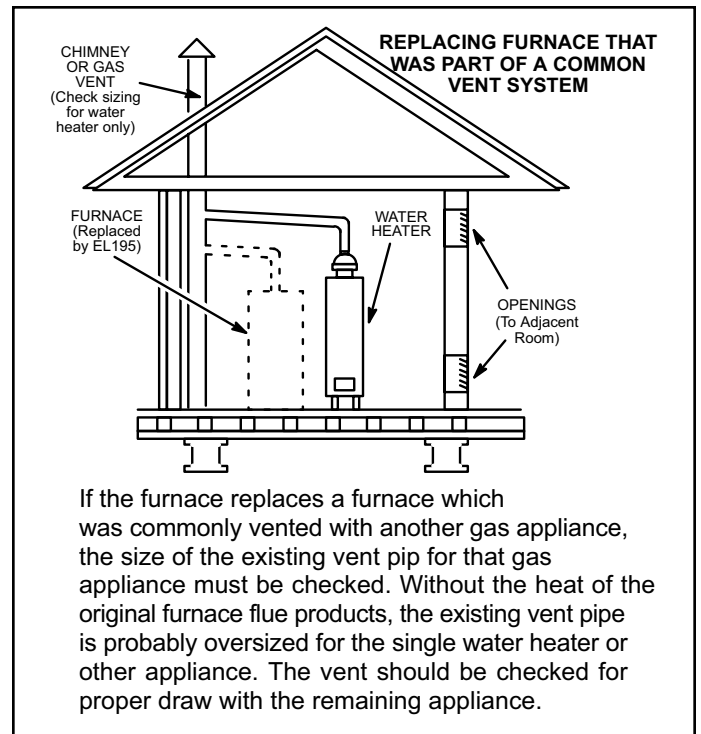

Figure 20.

Exhaust Piping (Figure 22)

Route piping to outside of structure. Continue with installation following instructions given in piping termination section.

CAUTION

Do not discharge exhaust into an existing stack or stack that also serves another gas appliance. If vertical discharge through an existing unused stack is required, insert PVC pipe inside the stack until the end is even with the top or outlet end of the metal stack.

CAUTION

The exhaust vent pipe operates under positive pressure and must be completely sealed to prevent leakage of combustion products into the living space.

Vent Piping Guidelines

NOTE: Allied has approved the use of DuraVent® and Centrotherm manufactured vent pipe and terminations as an option to PVC. When using the PolyPro® by DuraVent or InnoFlue® by Centrotherm venting system the vent pipe requirements stated in the unit installation instruction – minimum & maximum vent lengths, termination clearances, etc. – apply and must be followed. Follow the instructions provided with PoyPro by DuraVent and InnoFlue by Centrotherm venting system for assembly or if requirements are more restrictive. The PolyPro by DuraVent and InnoFlue by Centrotherm venting system must also follow the uninsulated and unconditioned space criteria listed in Table 12.

The A93DF1E / 92G1DFE can be installed as either a Non-Direct Vent or a Direct Vent gas central furnace.

NOTE: In Non-Direct Vent installations, combustion air is taken from indoors and flue gases are discharged outdoors. In Direct Vent installations, combustion air is taken from outdoors and flue gases are discharged outdoors.

Intake and exhaust pipe sizing -- Size pipe according to Table 10 and Table 11A through Table 11B. Count all elbows in side and outside the home. Table 10 lists the minimum vent pipe lengths permitted. Table 11A through Table 11B lists the maximum pipe lengths permitted.

Regardless of the diameter of pipe used, the standard roof and wall terminations described in section Exhaust Piping Terminations should be used. Exhaust vent termination pipe is sized to optimize the velocity of the exhaust gas as it exits the termination. Refer to Table 13.

In some applications which permit the use of several different sizes of vent pipe, a combination vent pipe may be used. Contact Allied Technical Services Department for assistance in sizing vent pipe in these applications.

NOTE: It is acceptable to use any pipe size which fits within the guidelines allowed in Table 11A or Table 11B.

NOTE: All horizontal runs of exhaust pipe must slope back toward unit. A minimum of 1/4" (6mm) drop for each 12" (305mm) of horizontal run is mandatory for drainage.

NOTE: Exhaust pipe MUST be glued to furnace exhaust fittings.

NOTE: Exhaust piping should be checked carefully to make sure there are no sags or low spots.

IMPORTANT

Do not use screens or perforated metal in exhaust or intake terminations. Doing so will cause freeze-ups and may block the terminations.

Capacity	Min. Vent Length*
045, 070, 090	15 ft or 5 ft plus 2 elbows or 10 ft plus 1 elbow
*Any approved termination may be added to the minimum length listed.	

Table 10. Minimum Vent Pipe Lengths

Use the following steps to correctly size vent pipe diameter.

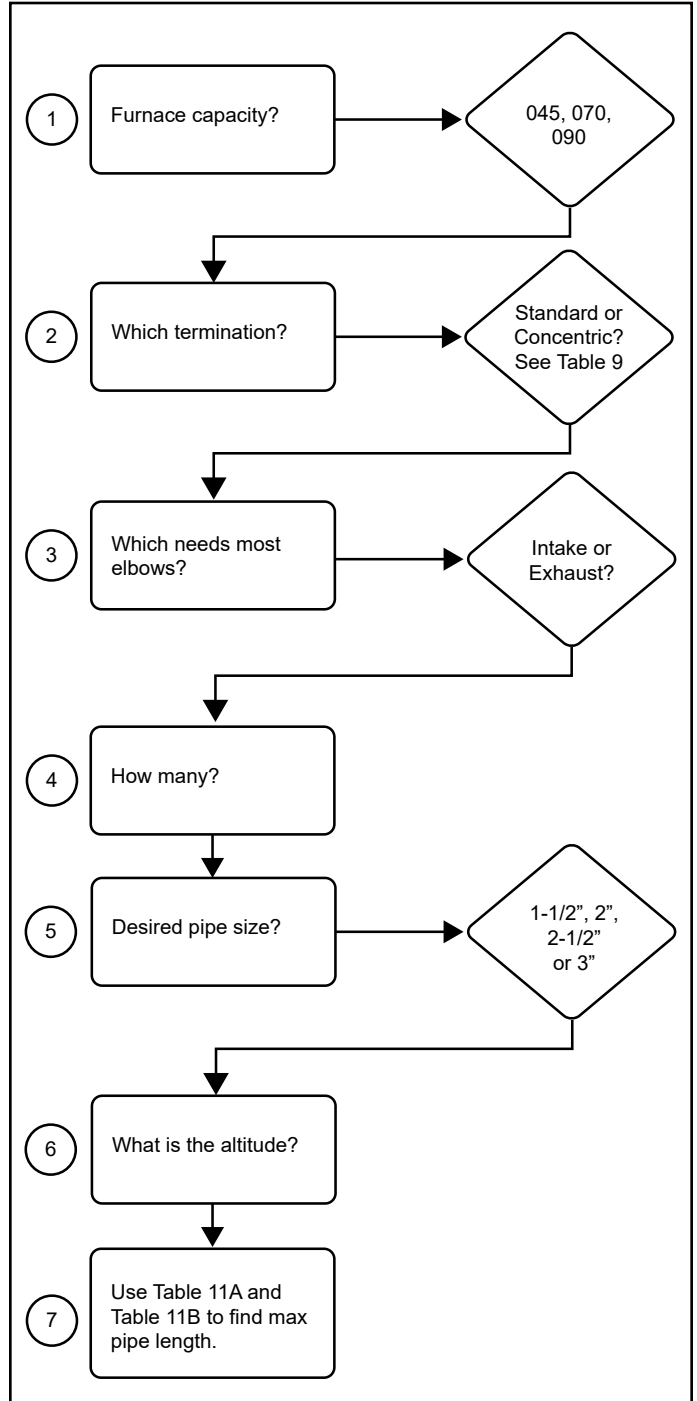

Figure 21. Vent Pipe Diameter Sizing

Maximum Allowable Intake or Exhaust Vent Length in Feet

Standard Termination at Elevation 0 - 10,000 ft												
Number of 90° Elbows Used	1-1/2" Pipe			2" Pipe			2-1/2" Pipe			3" Pipe		
	Model			Model			Model			Model		
	045	070	090	045	070	090	045	070	090	045	070	090
1	20	15	n/a	61	46	24	95	80	43	127	127	108
2	15	10		56	41	19	90	75	38	122	122	103
3	10	n/a		51	36	14	85	70	33	117	117	98
4	n/a			46	31	n/a	80	65	28	112	112	93
5				41	26		75	60	23	107	107	88
6				36	21		70	55	18	102	102	83
7				31	16		65	50	13	97	97	78
8				26	11		60	45	n/a	92	92	73
9				21	n/a		55	40		87	87	68
10				16			50	35		82	82	63
Concentric Termination Elevation 0 - 10,000 ft												
Number of 90° Elbows Used	1-1/2" Pipe			2" Pipe			2-1/2" Pipe			3" Pipe		
	Model			Model			Model			Model		
	045	070	090	045	070	090	045	070	090	045	070	090
1	15	10	n/a	53	38	22	90	70	39	111	111	104
2	10	n/a		48	33	17	85	65	34	106	106	99
3	n/a			43	28	12	80	60	29	101	101	94
4				38	23	n/a	75	55	24	96	96	89
5				33	18		70	50	19	91	91	84
6				28	13		65	45	14	86	86	79
7				23	n/a		60	40	n/a	81	81	74
8				18			55	35		76	76	69
9				13			50	30		71	71	64
10		n/a		45			25	66		66	59	
*Size intake and exhaust pipe length separately. Values in table are for Intake OR Exhaust, not combined total. Both Intake and Exhaust must be same pipe size.												

Table 11A.

Maximum Allowable Exhaust Vent Length with Furnace Installed in a Closet or Basement Using Ventilated Attic or Crawl Space for Intake in Feet

Standard Termination at Elevation 0 - 10,000 ft												
Number of 90° Elbows Used	1-1/2" Pipe			2" Pipe			2-1/2" Pipe			3" Pipe		
	Capacity			Capacity			Capacity			Capacity		
	045	070	090	045	070	090	045	070	090	045	070	090
1	15	10	n/a	51	36	14	85	100	28	107	107	88
2	10	n/a		46	31	9	80	95	23	102	102	83
3	n/a			41	26	4	75	90	18	97	97	78
4				36	21	n/a	70	85	13	92	92	73
5				31	16		65	80	8	87	87	68
6				26	11		60	75	n/a	82	82	63
7				21	6		55	70		77	77	58
8				16	n/a		50	65		72	72	53
9				11			45	60		67	67	48
10				6			40	55		62	62	43

NOTE: Additional vent pipe and elbows used to terminate the vent pipe outside the structure must be included in the total vent length calculation.

Table 11B.

TYPICAL EXHAUST PIPE CONNECTIONS

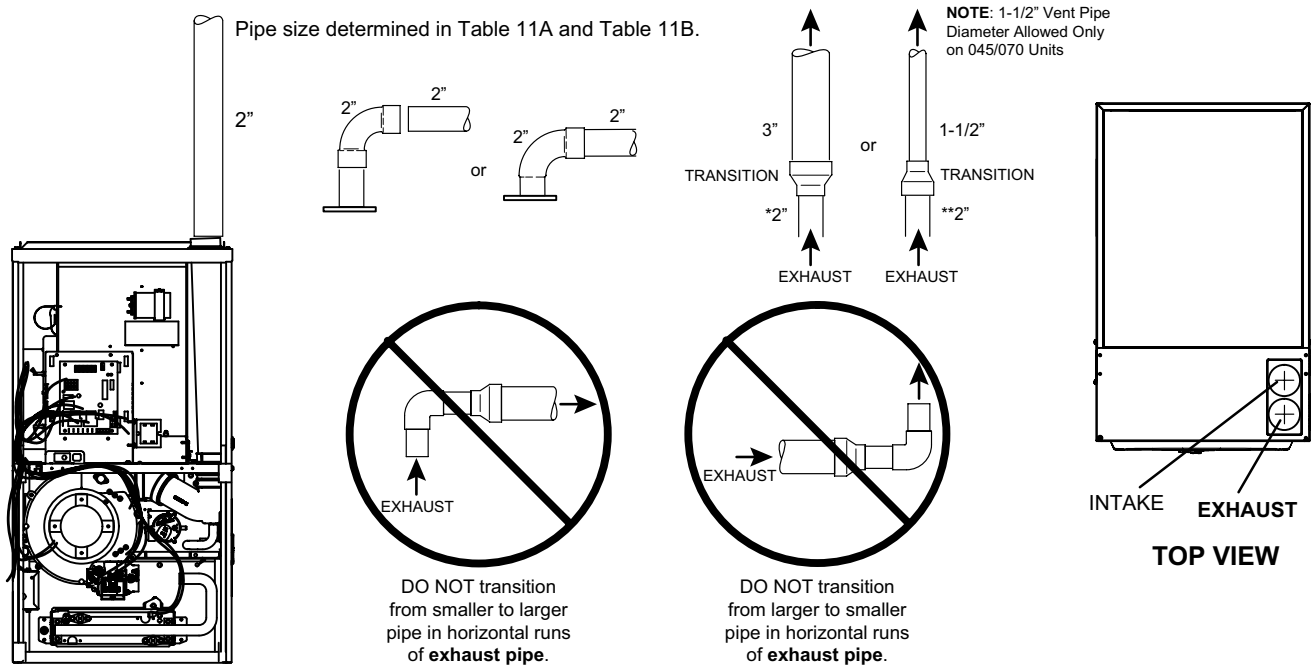

* When transitioning up in pipe size, use the shortest length of 2" PVC pipe possible.
 ** When transitioning down in pipe size, use at least 1 foot of 2" PVC pipe.
NOTE: Exhaust pipe and intake pipe must be the same diameter.

Figure 22. Typical Exhaust Pipe Connections

TYPICAL INTAKE PIPE CONNECTIONS

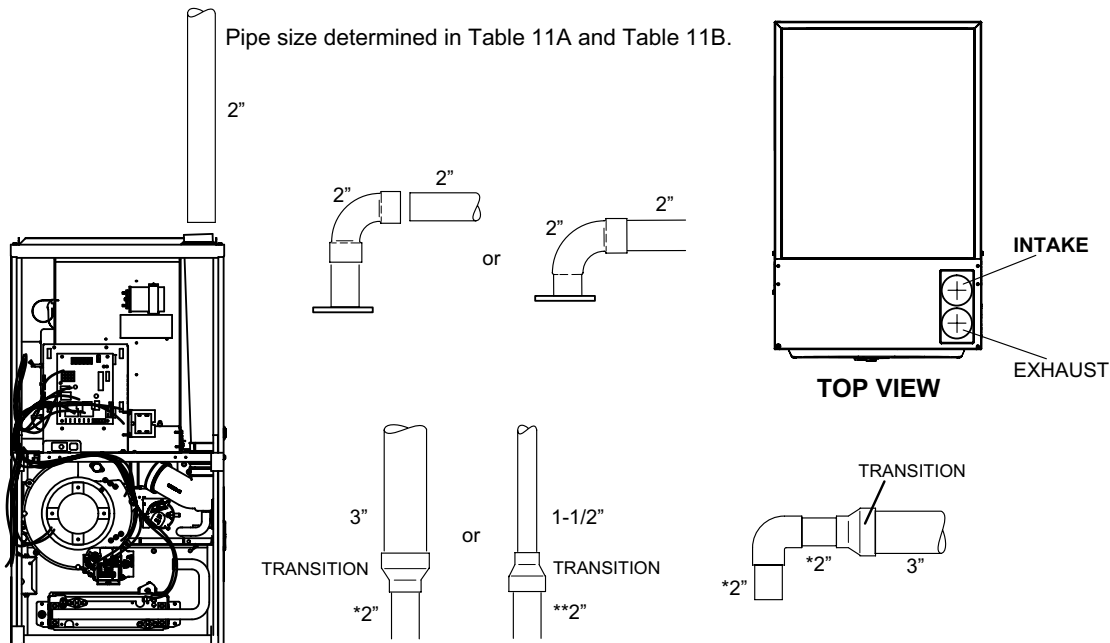

* When transitioning up in pipe size, use the shortest length of 2" PVC pipe possible.
 ** When transitioning down in pipe size, use at least 1 foot of 2" PVC pipe.
NOTE: Exhaust pipe and intake pipe must be the same diameter.

Figure 23. Typical Intake Pipe Connections (Direct Vent Applications)

Intake Piping

The A93DF1E / 92G1DFE furnace may be installed in either direct vent or non-direct vent applications. In non-direct vent applications, when intake air will be drawn into the furnace from the surrounding space, the indoor air quality must be considered and guidelines listed in Combustion, Dilution and Ventilation Air section must be followed.

Follow the next two steps when installing the unit in **Direct Vent applications**, where combustion air is taken from outdoors and flue gases are discharged outdoors. **The provided air intake screen must not be used in direct vent applications (outdoors).**

1. Use transition solvent cement or a sheet metal screw to secure the intake pipe to the inlet air connector.
2. Route piping to outside of structure. Continue with installation following instructions given in general guidelines for piping terminations and intake and exhaust piping terminations for direct vent sections. Refer to Table 11A and Table 11B for pipe sizes.

Follow the next two steps when installing the unit in **Non-Direct Vent applications** where combustion air is taken from indoors and flue gases are discharged outdoors.

1. Use field-provided materials and the factory-provided air intake screen to route the intake piping as shown in Figure 24. Maintain a minimum clearance of 3" (76mm) around the air intake opening. The air intake opening (with the protective screen) should always be directed forward, or sideways.
2. If intake air is drawn from a ventilated attic (Figure 25) or ventilated crawlspace (Figure 26) the exhaust vent length must not exceed those listed in Table 11B. If 3" diameter pipe is used, reduce to 2" diameter pipe at the termination point to accommodate the debris screen.
3. Use a sheet metal screw to secure the intake pipe to the connector, if desired.

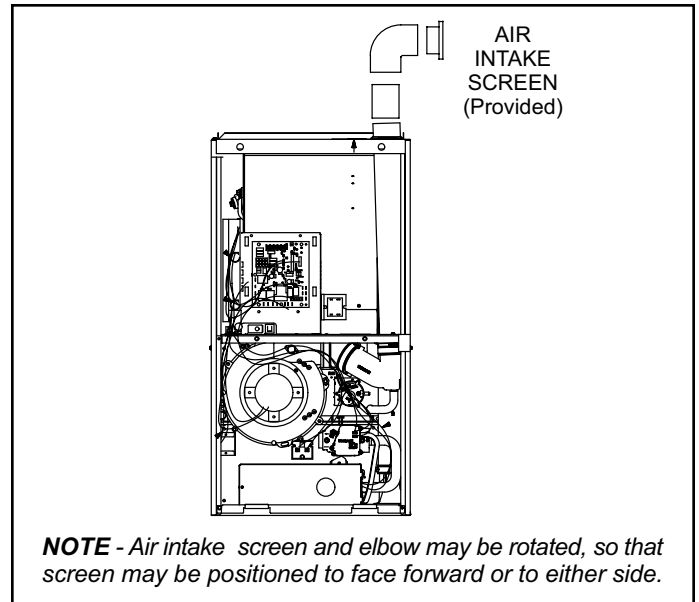

**Figure 24. Typical Air Intake Pipe Connections
Non-Direct Vent Applications**

CAUTION

If this unit is being installed in an application with combustion air coming in from a space serviced by an exhaust fan, power exhaust fan, or other device which may create a negative pressure in the space, take care when sizing the inlet air opening. The inlet air opening must be sized to accommodate the maximum volume of exhausted air as well as the maximum volume of combustion air required for all gas appliances serviced by this space.

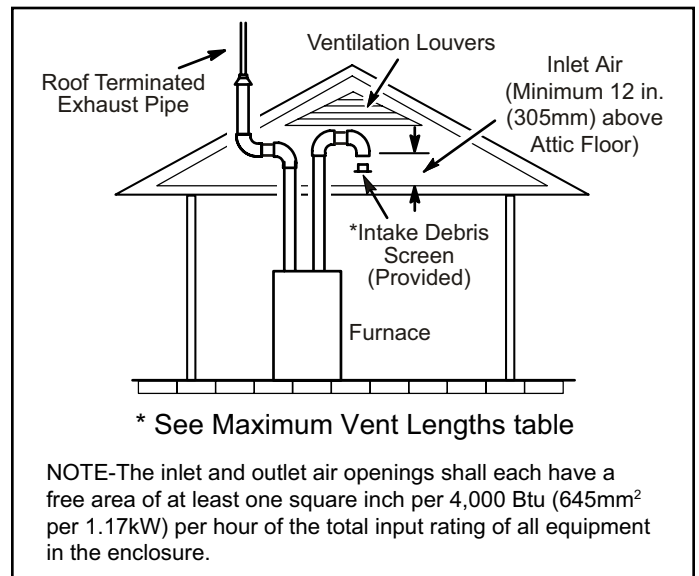

**Figure 25. Equipment in Confined Space
(Inlet Air from Ventilating Attic and Outlet Air to
Outside)**

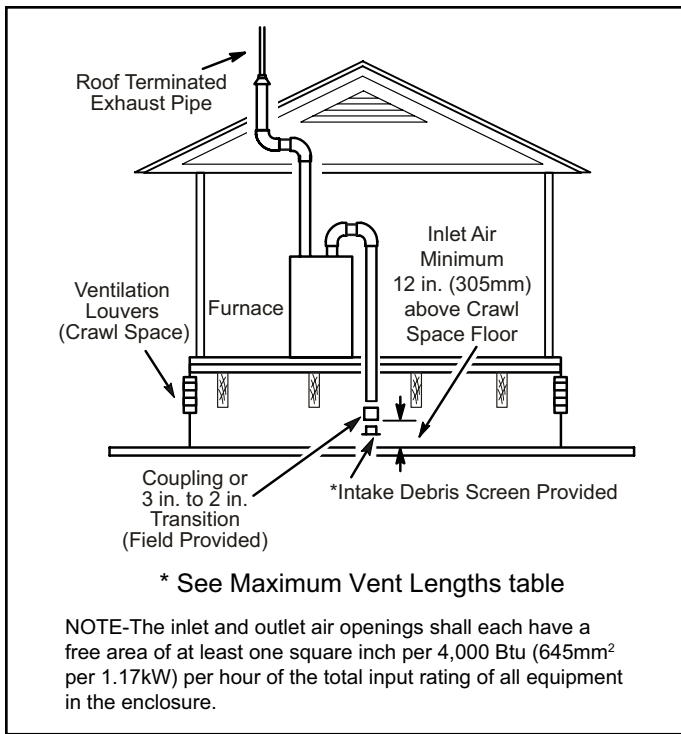

**Figure 26. Equipment in Confined Space
(Inlet Air from Ventilated Crawl Space and Outlet Air
to Outside)**

General Guidelines for Vent Terminations

In Non-Direct Vent applications, combustion air is taken from indoors and the flue gases are discharged to the outdoors. The A93DF1E / 92G1DFE is then classified as a non-direct vent, Category IV gas furnace.

In Direct Vent applications, combustion air is taken from outdoors and the flue gases are discharged to the outdoors. The A93DF1E / 92G1DFE is then classified as a direct vent, Category IV gas furnace.

In both Non-Direct Vent and Direct Vent applications, the vent termination is limited by local building codes. In the absence of local codes, refer to the current National Fuel Gas Code ANSI Z223-1/NFPA 54 in U.S.A., and current CSA-B149 Natural Gas and Propane Installation Codes in Canada for details.

Position termination according to location given in Figure 28 or Figure 37. In addition, position termination so it is free from any obstructions and 12" above the average snow accumulation.

At vent termination, care must be taken to maintain protective coatings over building materials (prolonged exposure to exhaust condensate can destroy protective coatings). It is recommended that the exhaust outlet not be located within 6 feet (1.8m) of a condensing unit because the condensate can damage the painted coating.

NOTE: See Table 12 for maximum allowed exhaust pipe length without insulation in unconditioned space during winter design temperatures below 32°F (0°C). If required exhaust pipe should be insulated with 1/2" (13mm) Armaflex or equivalent. In extreme cold climate areas, 3/4" (19mm) Armaflex or equivalent may be necessary. Insulation must be protected from deterioration. Armaflex with UV protection is permissible. Basements or other enclosed areas that are not exposed to the outdoor ambient temperature and are above 32 degrees F (0°C) are to be considered conditioned spaces.

▲ IMPORTANT

Do not use screens or perforated metal in exhaust terminations. Doing so will cause freeze-ups and may block the terminations.

▲ IMPORTANT

For Canadian Installations Only:

In accordance to CSA International B149 installation codes, the minimum allowed distance between the combustion air intake inlet and the exhaust outlet of other appliances shall not be less than 12 inches (305mm).

Maximum Allowable Exhaust Vent Pipe Length (in ft.) without Insulation in Unconditioned Space for Winter Design Temperatures Single - Stage High Efficiency Furnace

Winter Design Temperatures ¹ °F (°C)	Vent Pipe Diameter	Unit Input Size					
		045		070		090	
		PVC	² PP	PVC	² PP	PVC	² PP
32° to 21° (0 to -6)	1-1/2 in.	25	N/A	20	N/A	N/A	N/A
	2 in.	18	16	31	28	50	48
	2-1/2 in.	13	N/A	24	N/A	42	N/A
	3 in.	9	9	18	18	35	35
20° to 1° (-7 to -17)	1-1/2 in.	15	N/A	20	N/A	N/A	N/A
	2 in.	9	8	18	16	32	29
	2-1/2 in.	5	N/A	13	N/A	24	N/A
	3 in.	N/A	N/A	8	8	19	19
0° to -20° (-18 to -29)	1-1/2 in.	10	N/A	15	N/A	N/A	N/A
	2 in.	5	3	12	10	22	19
	2-1/2 in.	N/A	N/A	7	N/A	15	N/A
	3 in.	N/A	N/A	N/A	N/A	10	10

¹ Refer to 99% Minimum Design Temperature table provided in the current edition of the ASHRAE Fundamentals Handbook.

² Poly-Propylene vent pipe (PP) by Duravent and Centrotherm

NOTE - Concentric terminations are the equivalent of 5' and should be considered when measuring pipe length.

NOTE- Maximum uninsulated vent lengths listed may include the termination (vent pipe exterior to the structure) and cannot exceed 5 linear feet or the maximum allowable intake or exhaust vent length listed in Table 11A and Table 11B.

NOTE - If insulation is required in an unconditioned space, it must be located on the pipe closest to the furnace. See Figure 27.

Table 12.

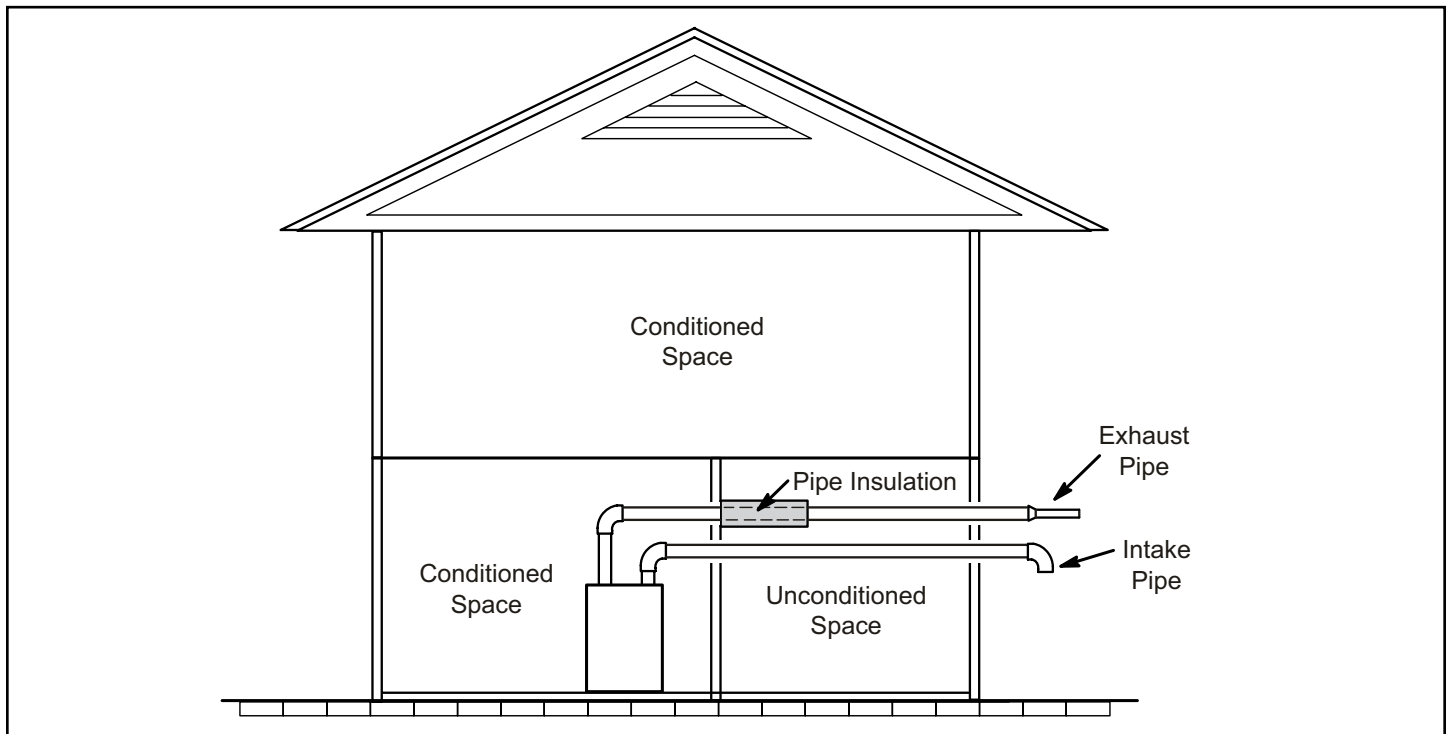
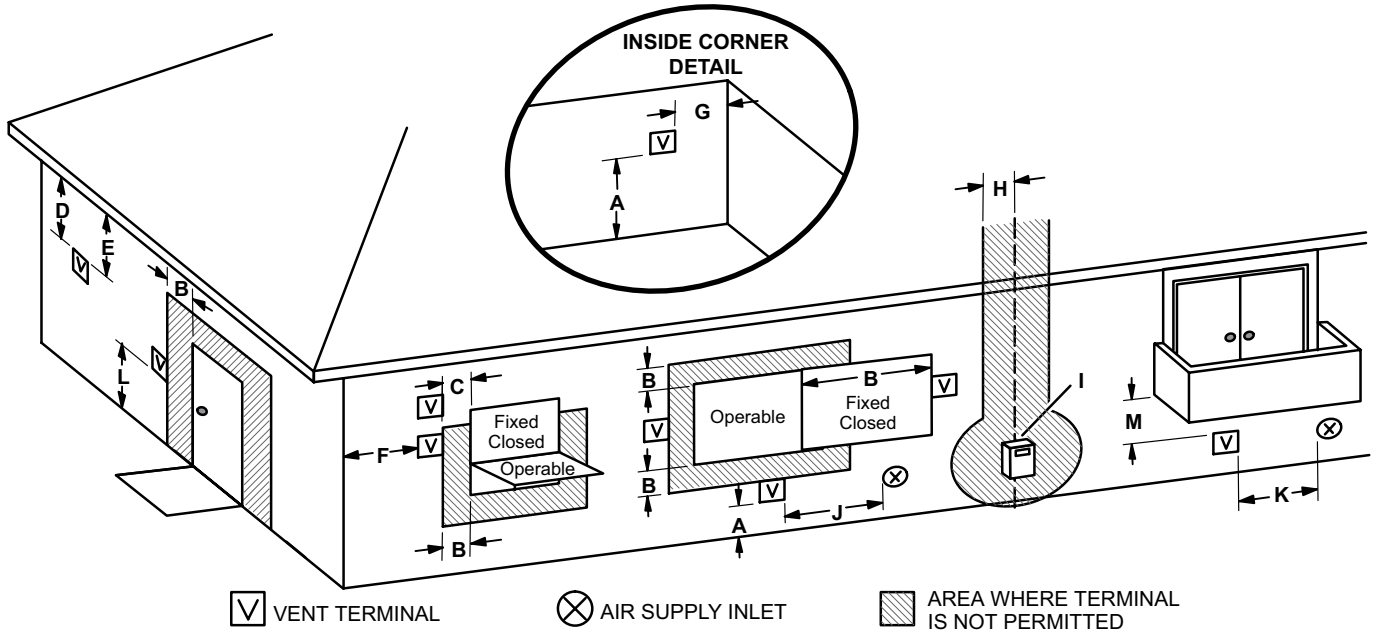

Figure 27. Insulating Exhaust Pipe in an Unconditioned Space

VENT TERMINATION CLEARANCES FOR DIRECT VENT INSTALLATIONS IN THE USA AND CANADA



	US Installations ¹	Canadian Installations ²	
A =	Clearance above grade, veranda, porch, deck or balcony	12 inches (305mm) or 12 in. (305mm) above average snow accumulation.	12 inches (305mm) or 12 in. (305mm) above average snow accumulation.
B =	Clearance to window or door that may be opened	6 inches (152mm) for appliances <10,000 Btuh (3kw), 9 inches (228mm) for appliances > 10,000 Btuh (3kw) and <50,000 Btuh (15kw), 12 inches (305mm) for appliances > 50,000 Btuh (15kw)	6 inches (152mm) for appliances <10,000 Btuh (3kw), 12 inches (305mm) for appliances > 10,000 Btuh (3kw) and <100,000 Btuh (30kw), 36 inches (.9m) for appliances > 100,000 Btuh (30kw)
C =	Clearance to permanently closed window	* 12"	* 12"
D =	Vertical clearance to ventilated soffit located above the terminal within a horizontal distance of 2 feet (610mm) from the center line of the terminal	* Equal to or greater than soffit depth	* Equal to or greater than soffit depth
E =	Clearance to unventilated soffit	* Equal to or greater than soffit depth	* Equal to or greater than soffit depth
F =	Clearance to outside corner	* No minimum to outside corner	* No minimum to outside corner
G =	Clearance to inside corner	*	*
H =	Clearance to each side of center line extended above meter / regulator assembly	3 feet (.9m) within a height 15 feet (4.5m) above the meter / regulator assembly	3 feet (.9m) within a height 15 feet (4.5m) above the meter / regulator assembly
I =	Clearance to service regulator vent outlet	* 3 feet (.9m)	3 feet (.9m)
J =	Clearance to non-mechanical air supply inlet to building or the combustion air inlet to any other appliance	6 inches (152mm) for appliances <10,000 Btuh (3kw), 9 inches (228mm) for appliances > 10,000 Btuh (3kw) and <50,000 Btuh (15kw), 12 inches (305mm) for appliances > 50,000 Btuh (15kw)	6 inches (152mm) for appliances <10,000 Btuh (3kw), 12 inches (305mm) for appliances > 10,000 Btuh (3kw) and <100,000 Btuh (30kw), 36 inches (.9m) for appliances > 100,000 Btuh (30kw)
K =	Clearance to mechanical air supply inlet	3 feet (.9m) above if within 10 feet (3m) horizontally	6 feet (1.8m)
L =	Clearance above paved sidewalk or paved driveway located on public property	* 7 feet (2.1m)	7 feet (2.1m)†
M =	Clearance under veranda, porch, deck or balcony	*12 inches (305mm)‡	12 inches (305mm)‡

¹ In accordance with the current ANSI Z223.1/NFPA 54 Natural Fuel Gas Code

² In accordance with the current CSA B149.1, Natural Gas and Propane Installation Code

† A vent shall not terminate directly above a sidewalk or paved driveway that is located between two single family dwellings and serves both dwellings.

‡ Permitted only if veranda, porch, deck or balcony is fully open on a minimum of two sides beneath the floor. Allied Air recommends avoiding this location if possible.

*For clearances not specified in ANSI Z223.1/NFPA 54 or CSA B149.1, clearance will be in accordance with local installation codes and the requirements of the gas supplier and these installation instructions."

Figure 28. Vent Termination Clearances for Direct Installations

Details of Intake and Exhaust Piping Terminations for Direct Vent Installations

NOTE: In Direct Vent installations, combustion air is taken from outdoors and flue gases are discharged to outdoors.

NOTE: Flue gas may be slightly acidic and may adversely affect some building materials. If any vent termination is used and the flue gases may impinge on the building material, a corrosion-resistant shield (minimum 24 inches square) must be used to protect the wall surface. If the optional tee is used, the protective shield is required. The shield should be constructed using wood, plastic, sheet metal or other suitable material. All seams, joints, cracks, etc. in the affected area should be sealed using an appropriate sealant. See Figure 40.

Intake and exhaust pipes may be routed either horizontally through and outside wall or vertically through the roof. In attic or closet installations, vertical termination through the roof is preferred. Figure 29 through Figure 36 show typical terminations.

1. Intake and exhaust terminations are not required to be in the same pressure zone. You may exit the intake on one side of the structure and the exhaust on another side (Figure 30). You may exit the exhaust out the roof and the intake out the side of the structure (Figure 31).
2. Intake and exhaust pipes should be placed as close together as possible at termination end (refer to illustrations). Minimum separation is 3" (76 mm) on roof terminations and 6" (152 mm) on sidewall terminations.
3. On roof terminations, the intake piping should terminate straight down using two 90° elbows (see Figure 29).
4. Exhaust piping must terminate straight out or up as shown. A reducer may be required on the exhaust piping at the point where it exits the structure to improve the velocity of exhaust away from the intake piping. See Table 13.

Capacity	Exhaust Pipe Size	Termination Pipe Size
*045 and 070	2" (51 mm), 2-1/2" (64 mm), 3" (76 mm)	1-1/2" (38 mm)
*090	3" (76 mm)	2" (51 mm)

* -045, -070, and -090 units with the flush mount termination must use the 1-1/2" accelerator supplied with the kit.

Table 13. Exhaust Pipe Termination Size Reduction

- NOTE:** Care must be taken to avoid recirculation of exhaust back into intake pipe.
5. On field supplied terminations for sidewall exit, exhaust piping may extend a maximum of 12 inches (305 mm) for 2" PVC and 20 inches (508 mm) for 3" (76 mm) PVC beyond the outside wall. Intake piping should be as short as possible. See Figure 40.

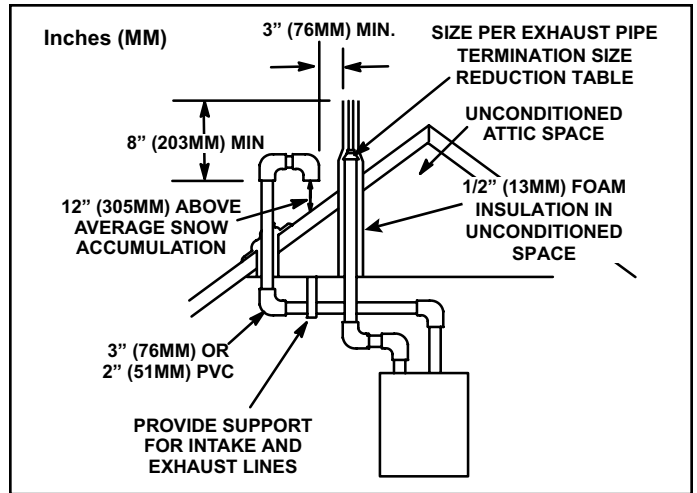

Figure 29. Direct Vent Roof Termination Kit (15F75 or 44J41)

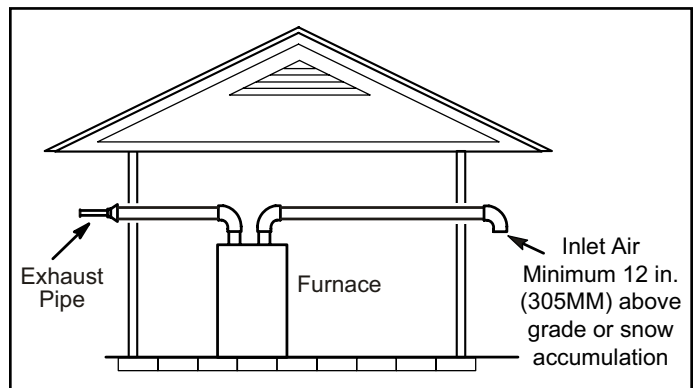

Figure 30. Exiting Exhaust and Intake Vent (no common pressure zone)

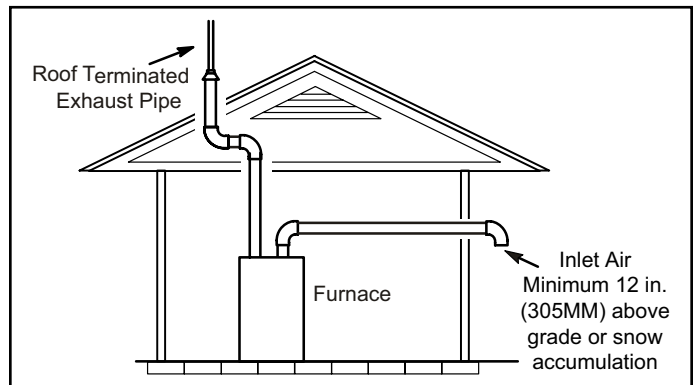
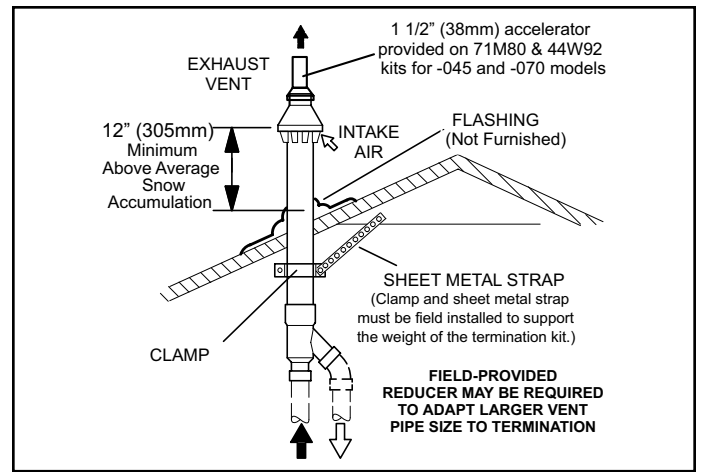

Figure 31. Exiting Exhaust and Intake Vent (no common pressure zone)

6. On field supplied terminations, a minimum distance between the end of the exhaust pipe and the end of the intake pipe without a termination elbow is 8" and a minimum distance of 6" with a termination elbow. See Figure 40.

7. If intake and exhaust piping must be run up a side wall to position above snow accumulation or other obstructions, piping must be supported. At least one bracket must be used within 6" from the top of the elbow and then every 24" (610mm) as shown in Figure 40, to prevent any movement in any direction. When exhaust and intake piping must be run up an outside wall, the exhaust piping must be terminated with pipe sized per Table 13. The intake piping may be equipped with a 90° elbow turndown. Using turndown will add 5 feet (1.5m) to the equivalent length of the pipe.
8. A multiple furnace installation may use a group of up to four terminations assembled together horizontally, as shown in Figure 33.



**Figure 34. Direct Vent Concentric Wall Termination
71M80, 69M29 or 60L46 (US)
44W92 or 44W93 (Canada)**

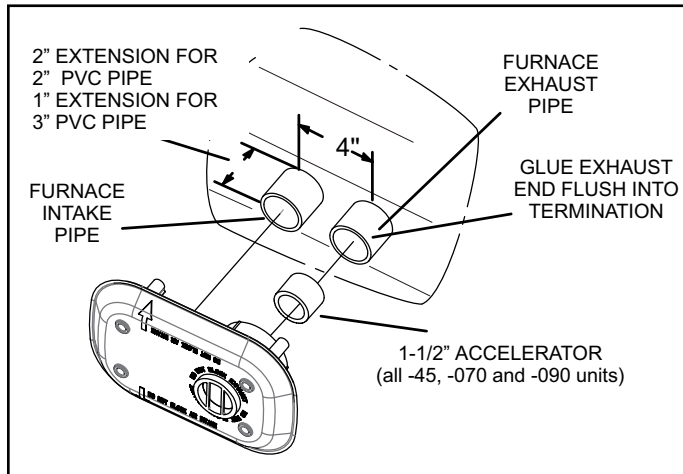

**Figure 32. Flush-Mount Side Wall Termination Kit
51W11 (US) or 51W12 (Canada)**

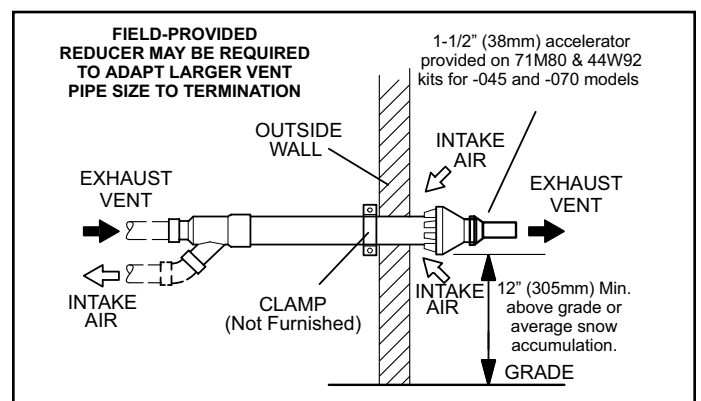

**Figure 35. Direct Vent Concentric Wall Termination
71M80, 69M29 or 60L46 (US)
44W92 or 44W93 (Canada)**

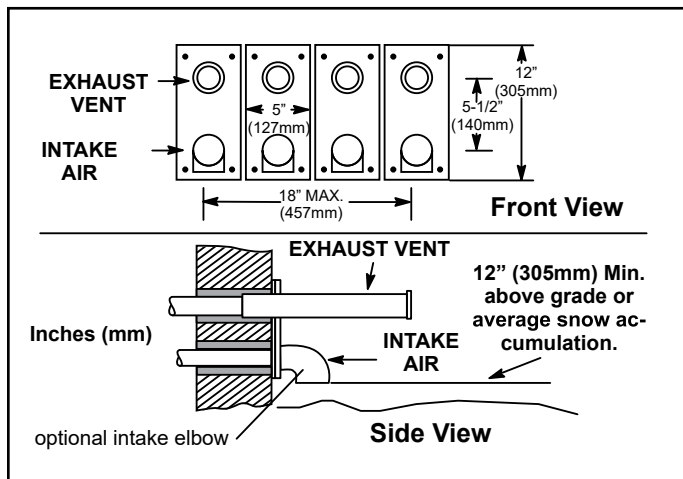

**Figure 33. Optional Vent Termination for Multiple Unit
Installation of Direct Vent Wall Termination Kit**

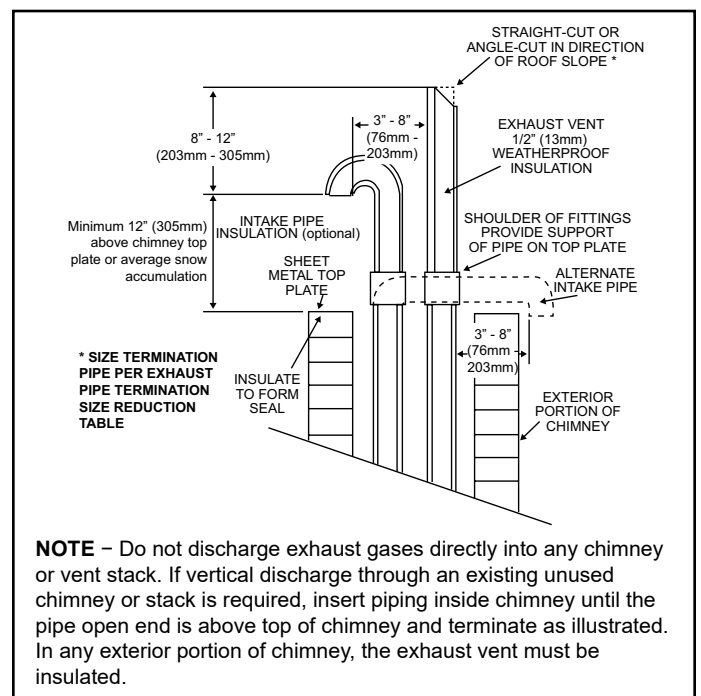

**Figure 36. Direct Vent Application Using Existing
Chimney**

NOTE – Do not discharge exhaust gases directly into any chimney or vent stack. If vertical discharge through an existing unused chimney or stack is required, insert piping inside chimney until the pipe open end is above top of chimney and terminate as illustrated. In any exterior portion of chimney, the exhaust vent must be insulated.

VENT TERMINATION CLEARANCES FOR NON-DIRECT VENT INSTALLATIONS IN THE US AND CANADA

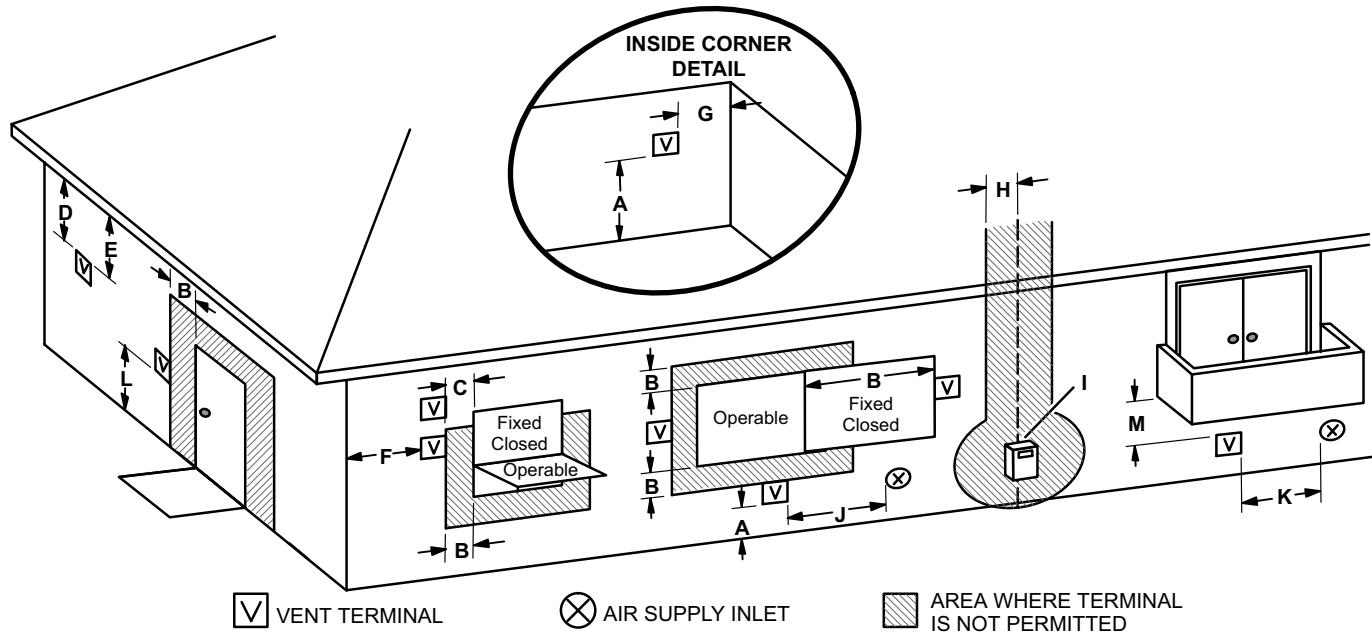

	US Installations ¹	Canadian Installations ²	
A =	Clearance above grade, veranda, porch, deck or balcony	12 inches (305mm) or 12 in. (305mm) above average snow accumulation.	12 inches (305mm) or 12 in. (305mm) above average snow accumulation.
B =	Clearance to window or door that may be opened	4 feet (1.2 m) below or to side of opening; 1 foot (30cm) above opening	6 inches (152mm) for appliances <10,000 Btuh (3kw), 12 inches (305mm) for appliances > 10,000 Btuh (3kw) and <100,000 Btuh (30kw), 36 inches (.9m) for appliances > 100,000 Btuh (30kw)
C =	Clearance to permanently closed window	* 12"	* 12"
D =	Vertical clearance to ventilated soffit located above the terminal within a horizontal distance of 2 feet (610 mm) from the center line of the terminal	* Equal to or greater than soffit depth.	* Equal to or greater than soffit depth.
E =	Clearance to unventilated soffit	* Equal to or greater than soffit depth.	* Equal to or greater than soffit depth.
F =	Clearance to outside corner	* No minimum to outside corner	* No minimum to outside corner
G =	Clearance to inside corner	*	*
H =	Clearance to each side of center line extended above meter / regulator assembly	* 3 feet (.9m) within a height 15 feet (4.5m) above the meter / regulator assembly	3 feet (.9m) within a height 15 feet (4.5m) above the meter / regulator assembly
I =	Clearance to service regulator vent outlet	* 3 feet (.9m)	3 feet (.9m)
J =	Clearance to non-mechanical air supply inlet to building or the combustion air inlet to any other appliance	4 feet (1.2 m) below or to side of opening; 1 foot (30 cm) above opening	6 inches (152mm) for appliances <10,000 Btuh (3kw), 12 inches (305mm) for appliances > 10,000 Btuh (3kw) and <100,000 Btuh (30kw), 36 inches (.9m) for appliances > 100,000 Btuh (30kw)
K =	Clearance to mechanical air supply inlet	3 feet (.9m) above if within 10 feet (3m) horizontally	6 feet (1.8m)
L =	Clearance above paved sidewalk or paved driveway located on public property	7 feet (2.1m)†	7 feet (2.1m)†
M =	Clearance under veranda, porch, deck or balcony	*12 inches (305mm)‡	12 inches (305mm)‡

¹ In accordance with the current ANSI Z223.1/NFPA 54 Natural Fuel Gas Code

² In accordance with the current CSA B149.1, Natural Gas and Propane Installation Code

† A vent shall not terminate directly above a sidewalk or paved driveway that is located between two single family dwellings and serves both dwellings.

‡ Permitted only if veranda, porch, deck or balcony is fully open on a minimum of two sides beneath the floor. Allied Air recommends avoiding this location if possible.

*For clearances not specified in ANSI Z223.1/NFPA 54 or CSA B149.1, clearance will be in accordance with local installation codes and the requirements of the gas supplier and these installation instructions."

Figure 37. Vent Termination Clearances for Non-Direct Installations

Details of Exhaust Piping Terminations for Non-Direct Vent Applications

Exhaust pipes may be routed either horizontally through an outside wall or vertically through the roof. In attic or closet installations, vertical termination through the roof is preferred. Figure 38 through Figure 39 show typical terminations.

1. Exhaust piping must terminate straight out or up as shown. The termination pipe must be sized as listed in Table 13. The specified pipe size ensures proper velocity required to move the exhaust gases away from the building.
2. On field supplied terminations for side wall exit, exhaust piping may extend a maximum of 12 inches (305mm) for 2" PVC and 20 inches (508mm) for 3" (76mm) PVC beyond the outside wall.
3. If exhaust piping must be run up a side wall to position above snow accumulation or other obstructions, piping must be supported every 24 inches (610mm). When exhaust piping must be run up an outside wall, any reduction in exhaust pipe size must be done after the final elbow.
4. Distance between exhaust pipe terminations on multiple furnaces must meet local codes.

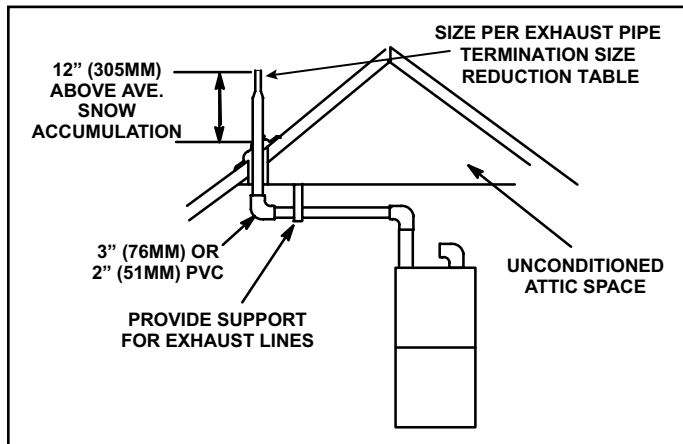

**Figure 38. Non-Direct Vent Roof Termination Kit
15F75 or 44J41)**

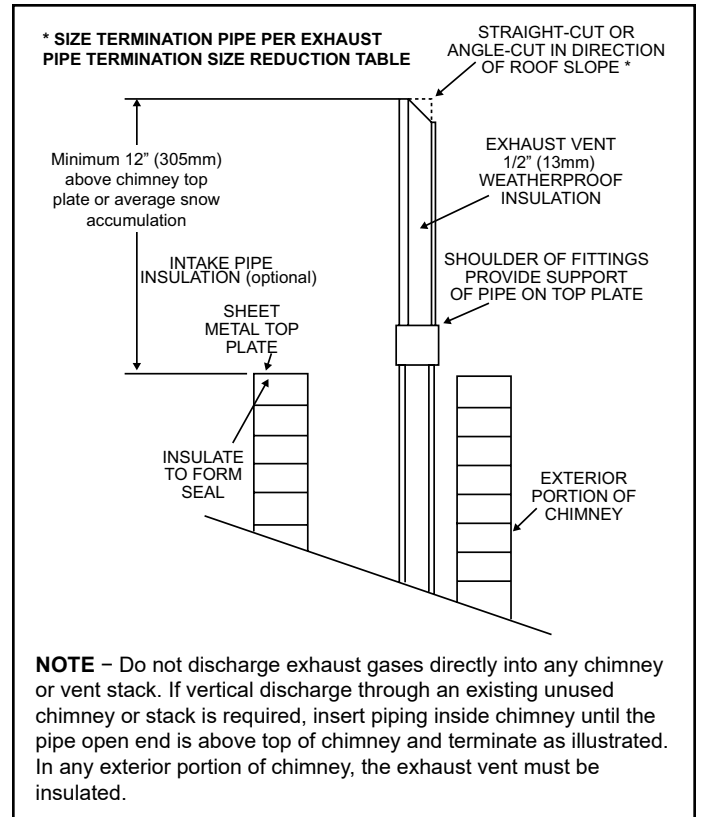
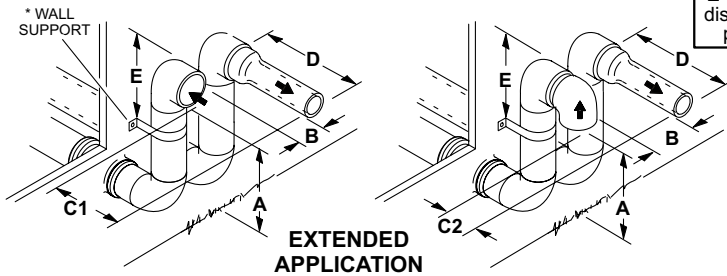
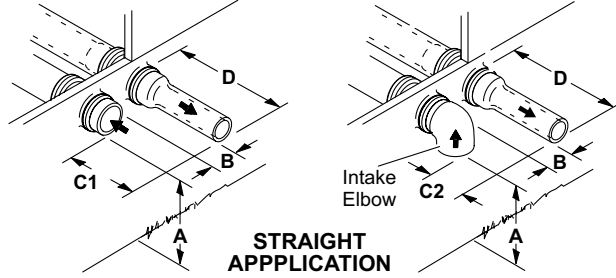

Figure 39. Non-Direct Vent Application Using Existing Chimney

FIELD FABRICATED WALL TERMINATION

NOTE - FIELD-PROVIDED REDUCER MAY BE REQUIRED TO ADAPT LARGER VENT PIPE SIZE TO TERMINATION



	2" (51mm) Vent Pipe	3" (76mm) Vent Pipe
A - Minimum clearance above grade or average snow accumulation	12" (305 mm)	12" (305 mm)
B - Maximum horizontal separation between intake and exhaust	6" (152 mm)	6" (152 mm)
C1 -Minimum from end of exhaust to inlet of intake	8" (203 mm)	8" (203 mm)
C2 -Minimum from end of exhaust to inlet of intake	6" (152 mm)	6" (152 mm)
D - Maximum exhaust pipe length	12" (305 mm)	20" (508 mm)
E - Maximum wall support distance from top of each pipe (intake/exhaust)	6" (152 mm)	6" (152 mm)

* Use wall support every 24" (610 mm). Use two wall supports if extension is greater than 24" (610 mm) but less than 48" (1219 mm).
NOTE - One wall support must be within 6" (152 mm) from top of each pipe (intake and exhaust) to prevent movement in any direction.

ALTERNATE TERMINATIONS (TEE & FORTY-FIVE DEGREE ELBOWS ONLY)

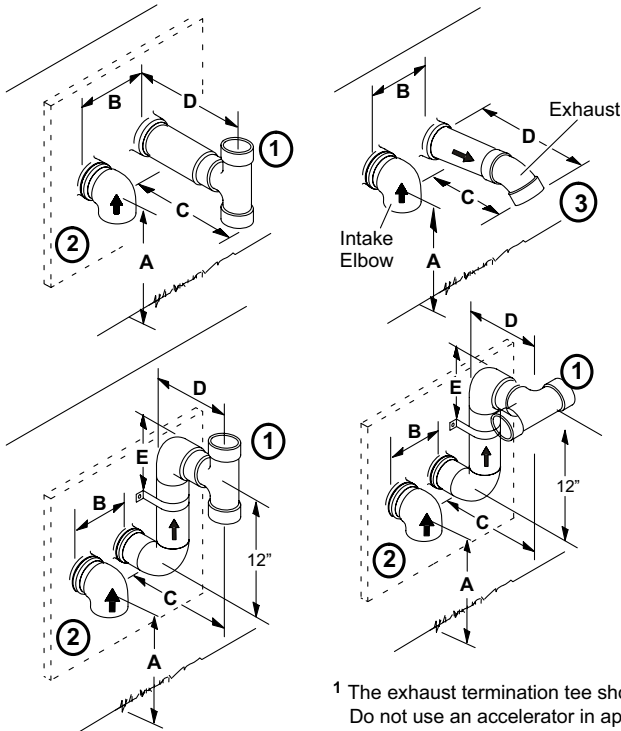

	2" (51MM) Vent Pipe	3" (76MM) Vent Pipe
A - Clearance above grade or average snow accumulation	12" (305 mm) Min.	12" (305 mm) Min.
B - Horizontal separation between intake and exhaust	6" (152 mm) Min. 24" (610 mm) Max.	6" (152 mm) Min. 24" (610 mm) Max.
C - Minimum from end of exhaust to inlet of intake	9" (227 mm) Min.	9" (227 mm) Min.
D - Exhaust pipe length	12" (305 mm) Min. 16" (405 mm) Max.	12" (305 mm) Min. 20" (508 mm) Max.
E - Wall support distance from top of each pipe (intake/exhaust)	6" (152 mm) Max.	6" (152 mm) Max.

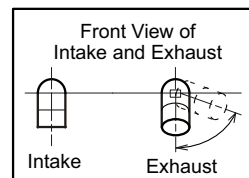

- 1 The exhaust termination tee should be connected to the 2" or 3" PVC flue pipe as shown in the illustration. Do not use an accelerator in applications that include an exhaust termination tee. The accelerator is not required.
- 2 As required. Flue gas may be acidic and may adversely affect some building materials. If a side wall vent termination is used and flue gases will impinge on the building materials, a corrosion-resistant shield (24 inches square) should be used to protect the wall surface. If optional tee is used, the protective shield is recommended. The shield should be constructed using wood, sheet metal or other suitable material. All seams, joints, cracks, etc. in affected area, should be sealed using an appropriate sealant.
- 3 Exhaust pipe 45° elbow can be rotated to the side away from the combustion air inlet to direct exhaust away from adjacent property. The exhaust must never be directed toward the combustion air inlet.

Figure 40.

Condensate Piping

This unit is designed for either right- or left-side exit of condensate piping. Refer to Figure 41 for condensate trap locations.

NOTE: *If necessary the condensate trap may be installed up to 5' away from the furnace. Use PVC pipe to connect trap to furnace condensate outlet. Piping from furnace must slope down a minimum of 1/4" per ft. toward trap.*

1. Determine which side condensate piping will exit the unit, location of trap, field-provided fittings and length of PVC pipe required to reach available drain.
2. For furnaces with a 1/2" drain connection use a 3/8 allen wrench and remove plug (Figure 41) from the cold end header box at the appropriate location on the side of the unit. Install field-provided 1/2 NPT male fitting into cold end header box. For furnaces with a 3/4" drain connection use a large flat head screw driver or a 1/2" drive socket extension and remove plug. Install provided 3/4 NPT street elbow fitting into cold end header box. Use Teflon tape or appropriate pipe dope.
3. Install the cap over the clean out opening at the base of the trap. Secure with clamp. See Figure 47 or Figure 48.
4. Install drain trap using appropriate PVC fittings, glue all joints. Glue the provided drain trap as shown in Figure 47 or Figure 48. Route the condensate line to an open drain. Condensate line must maintain a 1/4" downward slope from the furnace to the drain.
5. Figure 45 shows the furnace and evaporator coil using a separate drain. If necessary the condensate line from the furnace and evaporator coil can drain together. See Figure 46. The field provided vent must be a minimum 1" to a maximum 2" length above the condensate drain outlet connection.

NOTE: *Appropriately sized tubing and barbed fitting may be used for condensate drain. Attach to the drain on the trap using a hose clamp. See Figure 42.*

6. If unit will be started immediately upon completion of installation, prime trap per procedure outlined in Unit Start-Up section.

Condensate line must slope downward away from the trap to drain. If drain level is above condensate trap, condensate pump must be used. Condensate drain line should be routed within the conditioned space to avoid freezing of condensate and blockage of drain line. If this is not possible, a heat cable kit may be used on the condensate trap and line. Heating cable kit is available from Allied in various lengths; 6 ft. (1.8m) - kit no. 26K68 and 24 ft. (7.3m) - kit no. 26K69.

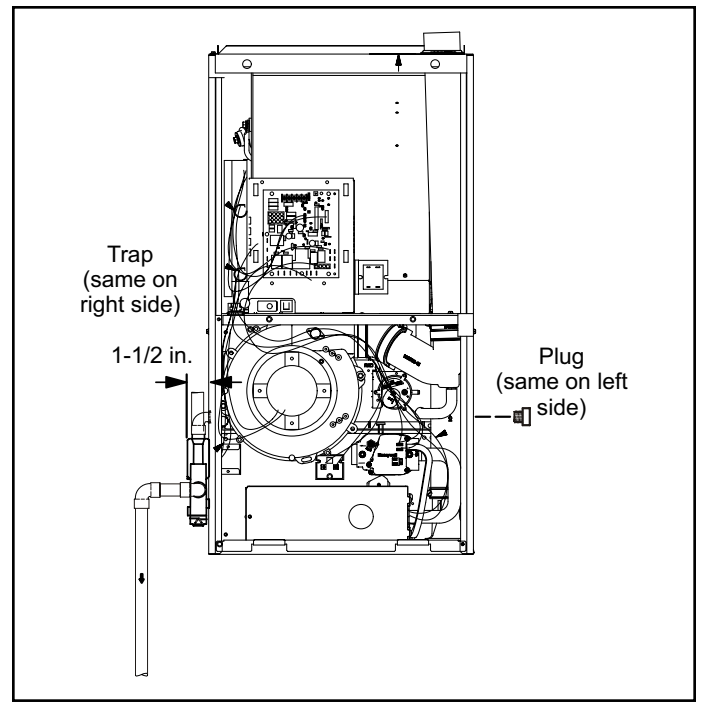

Figure 41. Condensate Trap and Plug Locations

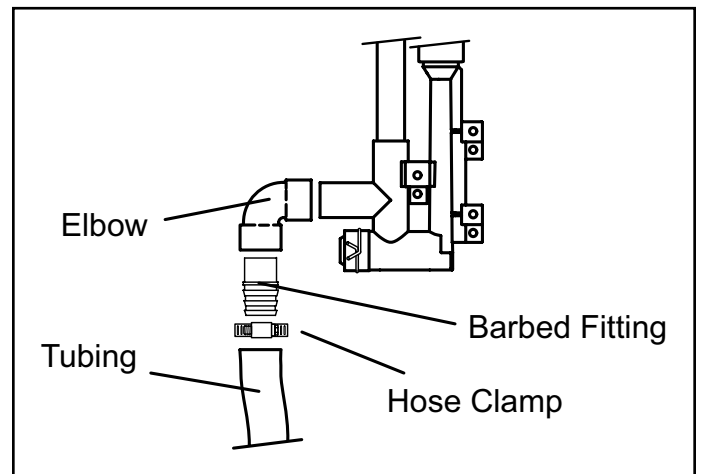

Figure 42. Field-Provided Drain Components

⚠ CAUTION

Do not use copper tubing or existing copper condensate lines for drain line.

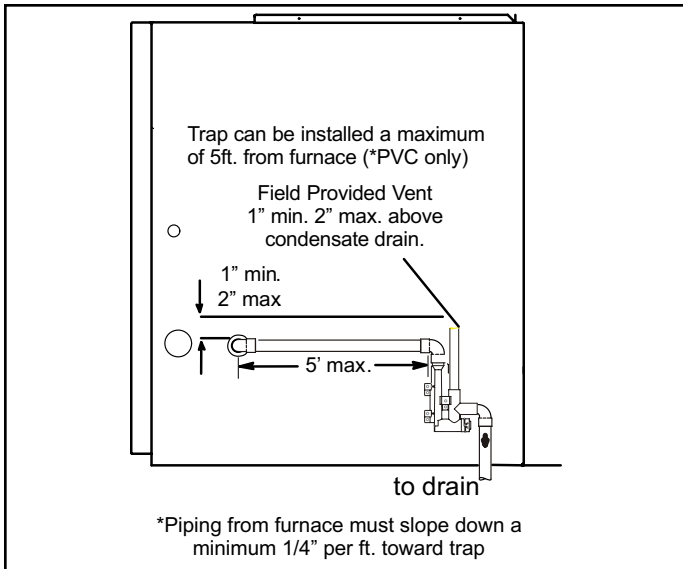

Figure 43. Condensate Trap Location (shown with right side exit of condensation)

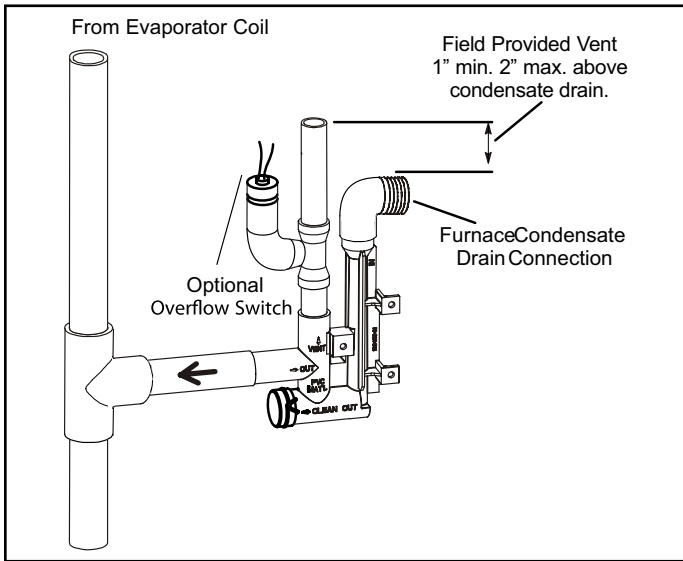

Figure 44. Condensate Trap with Optional Overflow Switch

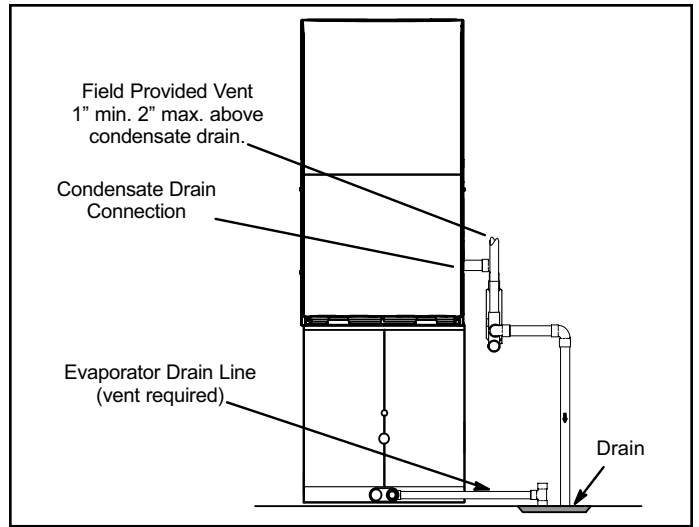

Figure 45. Unit with Cooling Coil Using Separate Drain

⚠ IMPORTANT

When combining the furnace and evaporator coil drains together, the A/C condensate drain outlet must be vented to relieve pressure in order for the furnace pressure switch to operate properly.

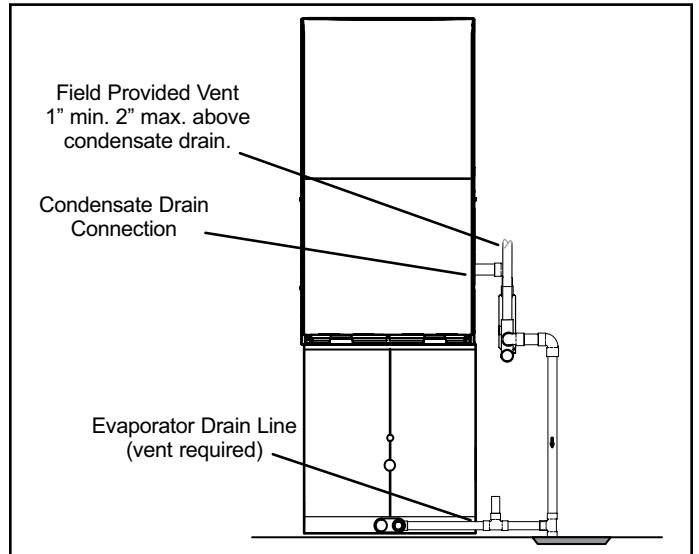
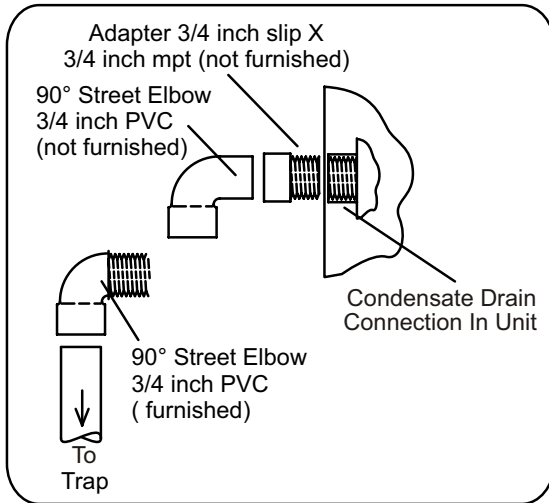
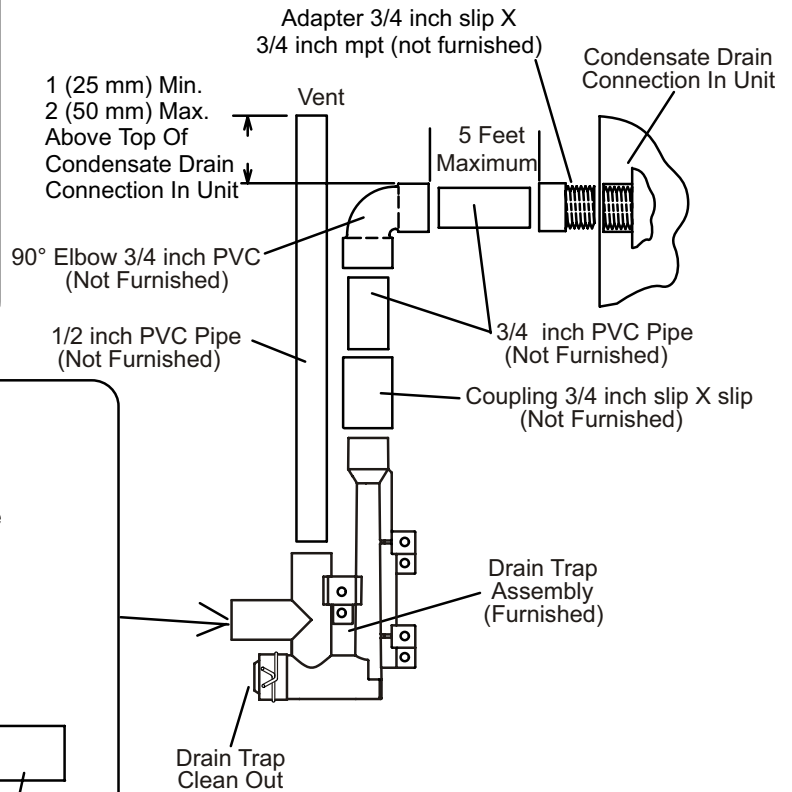
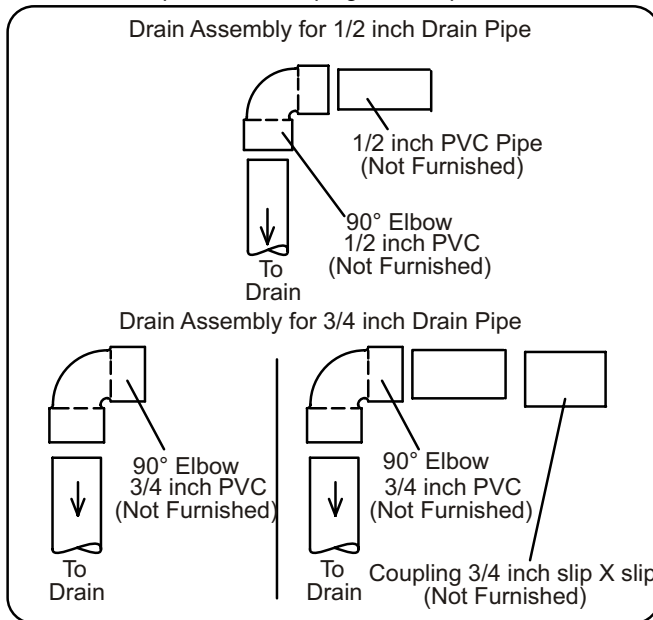

Figure 46. Evaporator Coil Using a Common Drain

Optional Condensate Drain Connection



Optional Drain Piping From Trap



Drain Trap Assembly with 1/2 inch Piping

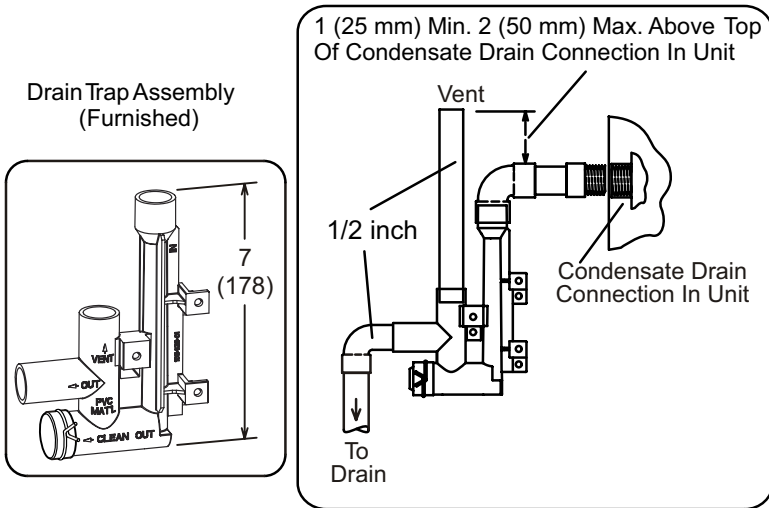

Drain Trap Assembly with 3/4 inch Piping

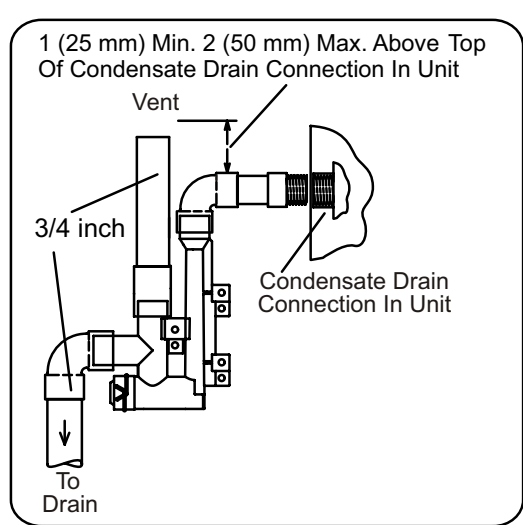
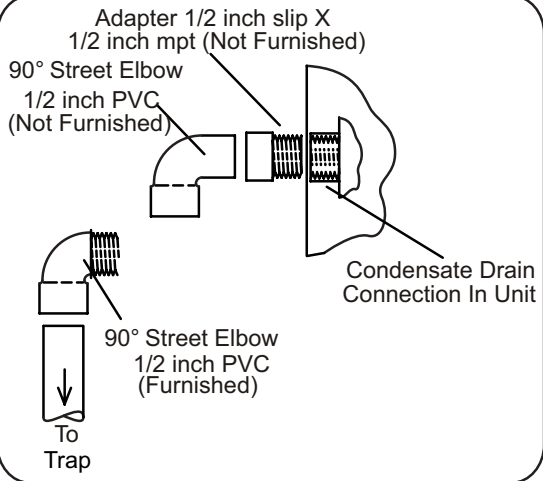
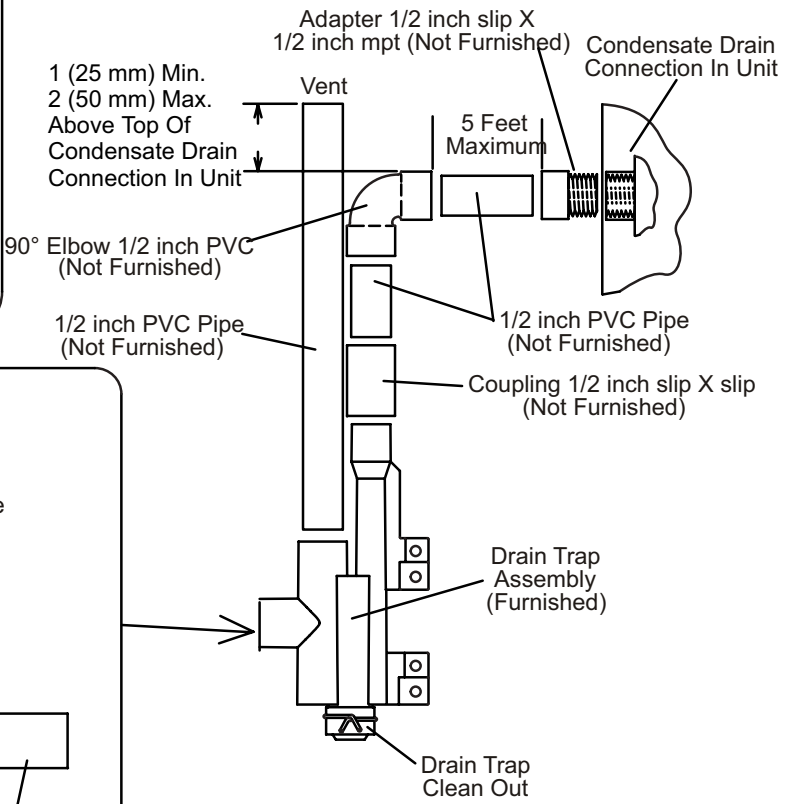
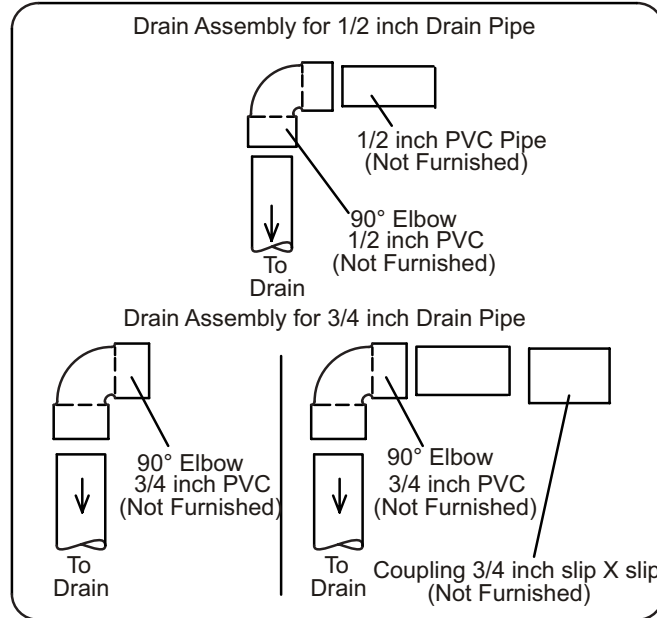

Figure 47. Trap / Drain Assembly Using 1/2" PVC or 3/4" PVC Cold End Header Box with 3/4" Drain Connection

Optional Condensate Drain Connection



Optional Drain Piping From Trap



Drain Trap Assembly with 3/4 inch Piping

Drain Trap Assembly with 1/2 inch Piping

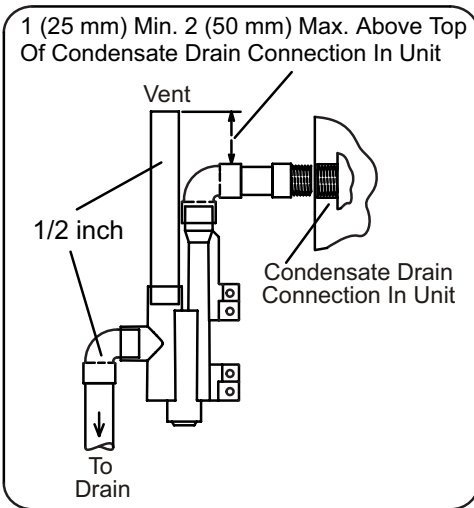

Drain Trap Assembly with 3/4 inch Piping

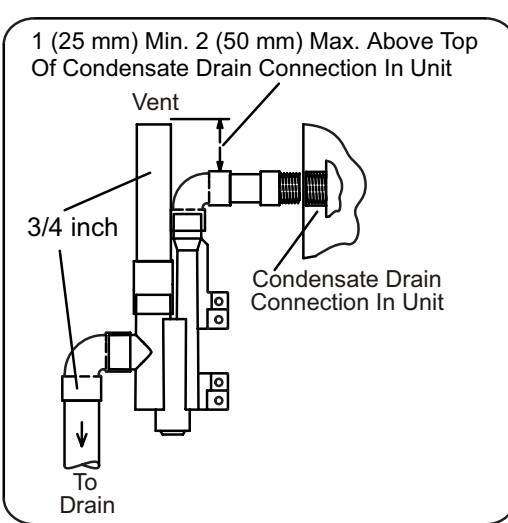

Drain Trap Assembly (Furnished)

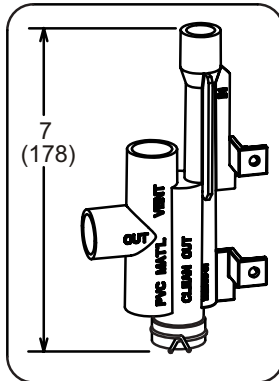

Figure 48. Trap / Drain Assembly Using 1/2" PVC or 3/4" PVC Cold End Header Box with 1/2" Drain Connection

Start-Up

Preliminary and Seasonal Checks

1. Inspect electrical wiring, both field and factory installed for loose connections. Tighten as required.
2. Check voltage at disconnect switch. Voltage must be within range listed on the nameplate. If not, consult the power company and have voltage condition corrected before starting unit.
3. Inspect condition of condensate traps and drain assembly. Disassemble and clean seasonally.

Heating Start-Up

BEFORE LIGHTING the unit, smell all around the furnace area for gas. Be sure to smell next to the floor because some gas is heavier than air and will settle on the floor.

The gas valve on the A93DF1E / 92G1DFE is equipped with a gas control switch. Use only your hand to move the switch. Never use tools. If the the switch will not move by hand, replace the valve. Do not try to repair it. Force or attempted repair may result in a fire or explosion.

Placing the Furnace Into Operation

A93DF1E / 92G1DFE units are equipped with an ignition system. Do not attempt to manually light burners on this furnace. Each time the thermostat calls for heat, the burners will automatically light. The ignitor does not get hot when there is no call for heat on units with ignition system.

Priming Condensate Trap

The condensate trap should be primed with water prior to start-up to ensure proper condensate drainage. Either pour 10 fl. oz. (300 ml) of water into the trap, or follow these steps to prime the trap:

1. Follow the lighting instructions to place the unit into operation.
2. Set the thermostat to initiate a heating demand.
3. Allow the burners to fire for approximately 3 minutes.
4. Adjust the thermostat to deactivate the heating demand.
5. Wait for the combustion air inducer to stop. Set the thermostat to initiate a heating demand and again allow the burners to fire for approximately 3 minutes.
6. Adjust the thermostat to deactivate the heating demand and again wait for the combustion air inducer to stop. At this point, the trap should be primed with sufficient water to ensure proper condensate drain operation.

WARNING

If you do not follow these instructions exactly, a fire or explosion may result causing property damage, personal injury or death.

Gas Valve Operation (Figure 49)

1. **STOP!** Read the safety information at the beginning of this section.
2. Set the thermostat to the lowest setting.
3. Turn off all electrical power to the unit.
4. This furnace is equipped with an ignition device which automatically lights the burners. Do not try to light the burners by hand.
5. Remove the access panel.
6. Move gas valve switch to OFF. See Figure 49.
7. Wait five minutes to clear out any gas. If you then smell gas, **STOP!** Immediately call your gas supplier from a neighbor's phone. Follow the gas supplier's instructions. If you do not smell gas go to next step.
8. Move gas valve switch to ON. See Figure 49.

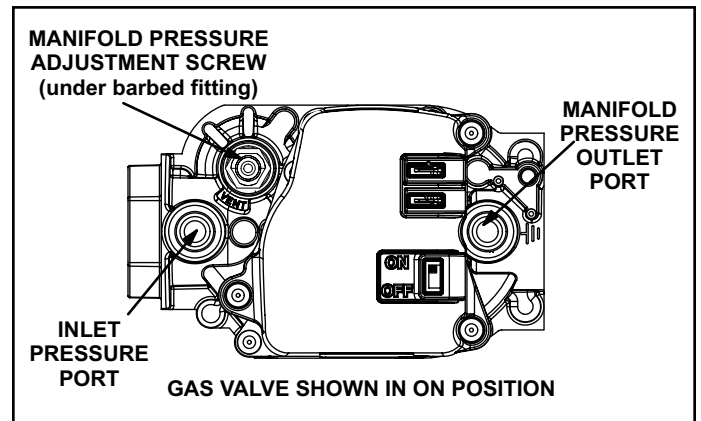

Figure 49. Gas Valve

9. Replace the access panel.
 10. Turn on all electrical power to to the unit.
 11. Set the thermostat to desired setting.
- NOTE:** When unit is initially started, steps 1 through 11 may need to be repeated to purge air from gas line.
12. If the appliance will not operate, follow the instructions "Turning Off Gas to Unit" and call your service technician or gas supplier.

Turning Off Gas to Unit

1. Set the thermostat to the lowest setting.
2. Turn off all electrical power to the unit if service is to be performed.
3. Remove the access panel.

4. Move gas valve switch to OFF.
5. Replace the access panel.

Failure To Operate

If the unit fails to operate, check the following:

1. Is the thermostat calling for heat?
2. Are access panels securely in place?
3. Is the main disconnect switch closed?
4. Is there a blown fuse or tripped breaker?
5. Is the filter dirty or plugged? Dirty or plugged filters will cause the limit control to shut the unit off.
6. Is gas turned on at the meter?
7. Is the manual main shut-off valve open?
8. Is the internal manual shut-off valve open?
9. Is the unit ignition system in lockout? If the unit locks out again, inspect the unit for blockages.

Heating System Service Checks

C.S.A. Certification

All units are C.S.A. design certified without modifications.

Refer to the A93DF1E / 92G1DFE Operation and Installation Instruction.

Gas Piping

⚠ CAUTION

If a flexible gas connector is required or allowed by the authority that has jurisdiction, black iron pipe shall be installed at the gas valve and extend outside the furnace cabinet. The flexible connector can then be added between the black iron pipe and the gas supply line.

⚠ WARNING

Do not over torque (800 in-lbs) or under torque (350 in-lbs) when attaching the gas piping to the gas valve.

Gas supply piping should not allow more than 0.5" W.C. drop in pressure between gas meter and unit. Supply gas pipe must not be smaller than unit gas connection.

Compounds used on gas piping threaded joints should be resistant to action of liquefied petroleum gases.

Testing Gas Piping

⚠ IMPORTANT

In case emergency shutdown is required, turn off the main shut-off valve and disconnect the main power to unit. These controls should be properly labeled by the installer.

When pressure testing gas lines, the gas valve must be disconnected and isolated. Gas valves can be damaged if subjected to more than 0.5 psig (14" W.C.). See Figure 50.

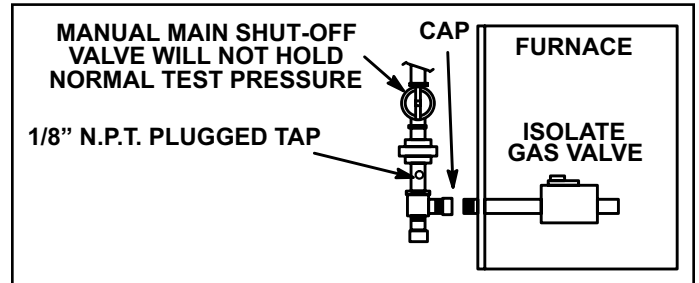

Figure 50.

When checking piping connections for gas leaks, use preferred means. Kitchen detergents can cause harmful corrosion on various metals used in gas piping. Use of a specialty Gas Leak Detector is strongly recommended.

⚠ WARNING

Do not use matches, candles, flame or any other source of ignition to check for gas leaks.

Gas Flow (Approximate)

Capacity	Seconds for One Revolution			
	Natural		LP	
	1 cu ft Dial	2 cu ft Dial	1 cu ft Dial	2 cu ft Dial
-45	80	160	200	400
-70	55	110	136	272
-90	41	82	102	204
Natural-1000 btu/cu ft LP-2500 btu/cu ft				

Table 14. Gas Meter Clocking Chart

Furnace should operate at least 5 minutes before checking gas flow. Determine time in seconds for two revolutions of gas through the meter. (Two revolutions assures a more accurate time.) Divide by two and compare to time in Table 14. If manifold pressure matches Table 16 and rate is incorrect, check gas orifices for proper size and restriction. Remove temporary gas meter if installed.

NOTE: To obtain accurate reading, shut off all other gas appliances connected to meter.

Supply Pressure Measurement

When testing supply gas pressure, use the 1/8" N.P.T. plugged tap located on the gas valve to facilitate test gauge connection. See Figure 49. Check gas line pressure with unit firing at maximum rate. Low pressure may result in erratic operation or underfire. High pressure can result in permanent damage to gas valve or overfire.

On multiple unit installations, each unit should be checked separately, with and without other units operating. Supply pressure must fall within range listed in Table 16.

Manifold Pressure Measurement

After line pressure has been checked and adjusted, check manifold pressure. Move pressure gauge to outlet pressure tap located on unit gas valve (GV1).

Checks of manifold pressure are made as verification of proper regulator adjustment.

1. Connect the test gauge positive side "+" to manifold pressure tap on gas valve.

2. Tee into the gas valve regulator vent hose and connect to test gauge negative "-".
3. Start unit and let run for 5 minutes to allow for steady state conditions.
4. After allowing unit to stabilize for 5 minutes, record manifold pressure and compare to value given in Table 16.
5. Shut unit off and remove manometer as soon as an accurate reading has been obtained. Take care to remove barbed fitting and replace threaded plug.
6. Start unit and perform leak check. Seal leaks if found.

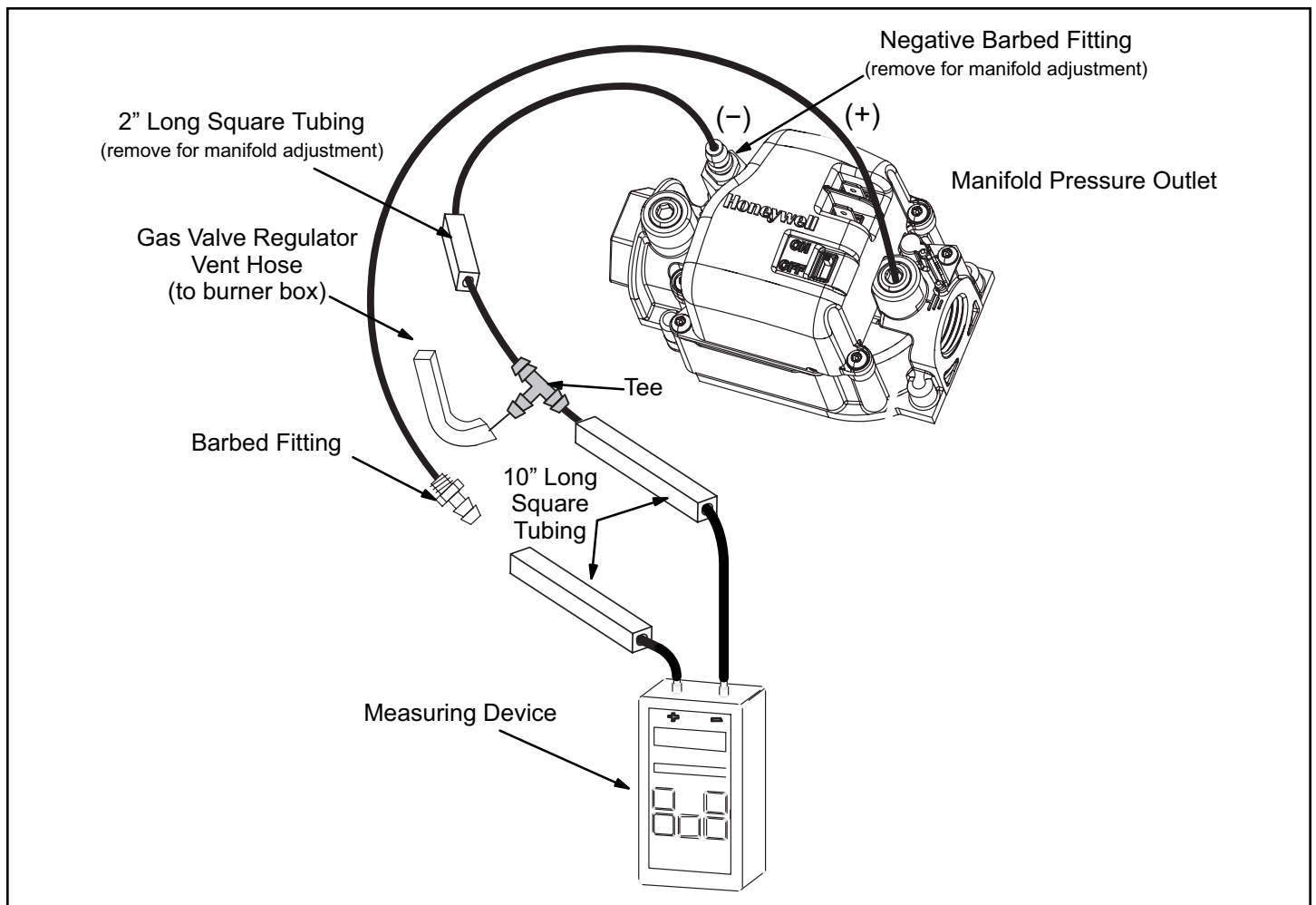

Figure 51.

Proper Combustion

Furnace should operate minimum 15 minutes with correct manifold pressure and gas flow rate before checking combustion. Take combustion sample beyond the flue outlet and compare to Table 15.

Capacity	CO ₂ % for Nat	CO ₂ % for L.P.
All	7.2 - 9	8 - 10
The maximum carbon monoxide reading should not exceed 100 ppm.		

Table 15.

High Altitude

NOTE: In Canada, certification for installations at elevations over 4500 feet (1372 m) is the jurisdiction of local authorities.

Some units installed at altitude of 4501 - 10,000 feet (1373 to 3048 m) may require a pressure switch change which can be ordered separately and a manifold de-rate. See Table 16 or Table 17 for manifold pressures at all altitudes. Table 18 lists conversion kit and Table 19 lists pressure switch requirements at varying altitudes.

The combustion air pressure switch is factory-set and requires no adjustment.

Unit	Fuel	Manifold Pressure	Supply Line
All	Nat	3.5	4.5 - 13.0
All	LP/Propane	10.0	11.0 - 13.0

NOTE - A natural to L.P. propane gas changeover kit is necessary to convert this unit. Refer to the changeover kit installation instruction for the conversion procedure.

Table 16. Supply Line and Manifold Pressure at All Altitudes (inches w.c.) for -1 Through -3 Units

Capacity	Gas	Manifold Pressure in. w.g.					Supply Line Pressure in. w.g. 0-10,000 ft.	
		0-4500 ft.	4501-5500 ft.	5501-6500 ft.	6501-7500 ft.	7501-10000 ft.		
All Sizes	Natural	3.5	3.3	3.2	3.1	3.5	4.5	13.0
	LP / Propane	10.0	9.4	9.1	8.9	10.0	11.0	13.0

NOTE: A natural to LP propane gas changeover kit is necessary to convert this unit. Refer to the changeover kit installation instruction for the conversion procedure.

Table 17. Manifold and Supply Line Pressure 0-10,000 ft.

Capacity	0 - 7,500 ft (0 - 2,286 m)		7,501 - 10,000 ft (2,286 - 3,048 m)	
	Natural to LP/Propane	LP/Propane to Natural	High Altitude Natural Burner Orifice Kit	High Altitude LP/Propane Burner Orifice Kit
All	11K50+	73W80*	51W01	11K45+

* Conversion requires installation of a gas valve regulator spring which is provided with the gas conversion Kit.

+ LP Kits include low line pressure switch.

Table 18. Burner Orifice Conversion Kits at Varying Altitudes

Capacity	0 - 4500 ft (0 - 1371m)	4501 - 7500 ft (1371 - 2286m)	7501 - 10000 ft (2286 - 3048m)
045	No Change	11U65	11U66
070			
090			

Pressure switch is factory set. No adjustment necessary. All models use the factory-installed pressure switch from 0-4500 feet (0-1371 m).

Table 19. Pressure Switch at Varying Altitudes

Proper Ground and Voltage

CAUTION



Electric Shock Hazard. Can cause injury or death. Unit must be properly grounded in accordance with national and local codes.

A poorly grounded furnace can contribute to premature ignitor failure. Use the following procedure to check for ground and voltage to the integrated control.

1. Measure the AC voltage between Line Neutral (spade terminals) and "C" terminal (low voltage terminal block) on the integrated control. See Figure 52. A wide variation in the voltage between Line Neutral and "C" as a function of load indicates a poor or partial ground.

Compare the readings to Table 20. If the readings exceed the maximum shown in Table 20, make repairs before operating the furnace.

2. In addition, measure the AC voltage from Line Hot to Line Neutral (spade terminals) on the integrated control. See Figure 52. This voltage should be in the range of 97 to 132 VAC

Furnace Status	Measurement VAC	
	Expected	Maximum
Power On Furnace Idle	0.3	2
CAI / Ignitor Energized	0.75	5
Indoor Blower Energized	Less than 2	10

Table 20.

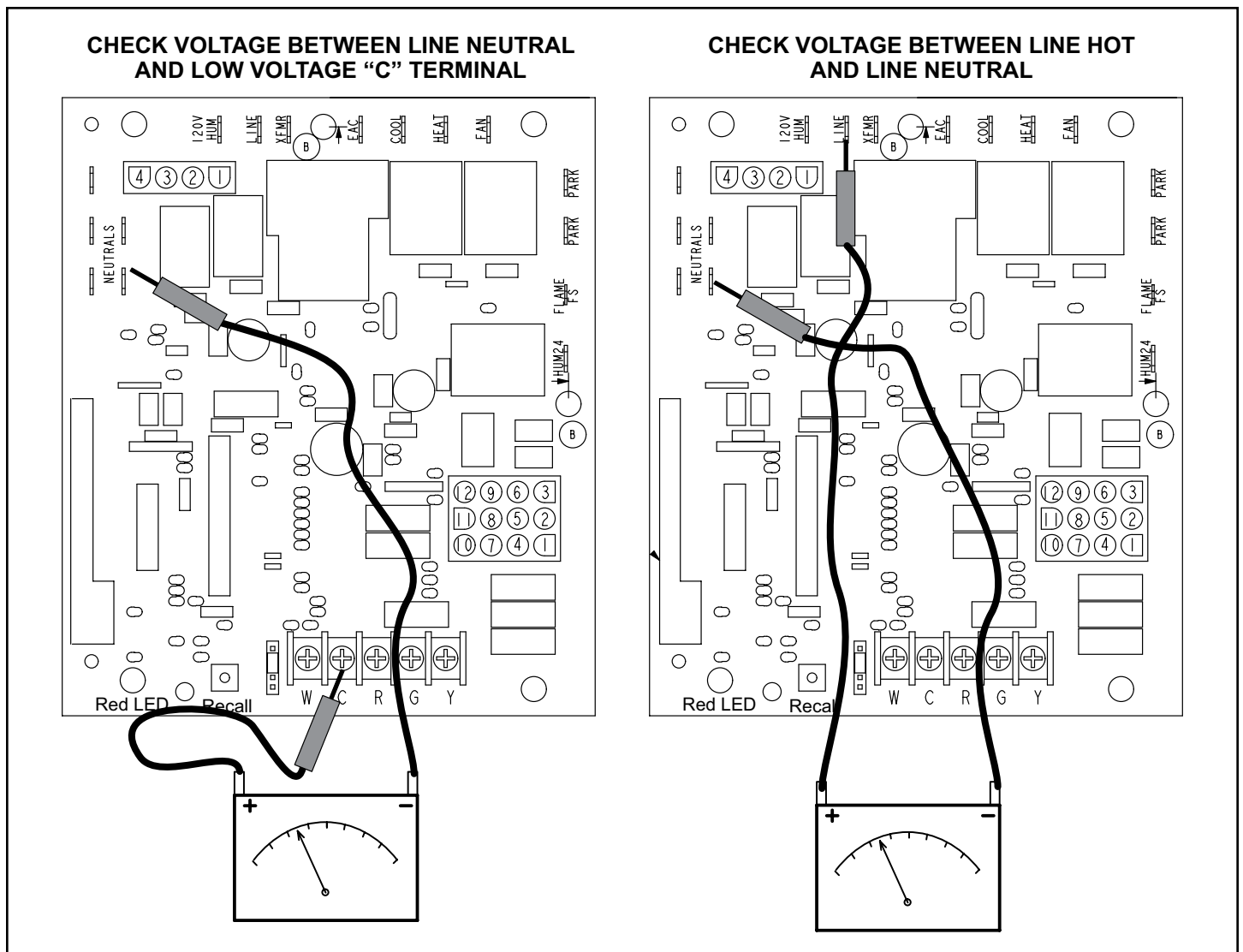

Figure 52.

Typical Operating Characteristics

Blower Operation and Adjustment

NOTE: The following is a generalized procedure and does not apply to all thermostat controls.

1. Blower operation is dependent on thermostat control system.
2. Generally, blower operation is set at thermostat subbase fan switch. With fan switch in ON position, blower operates continuously. With fan switch in AUTO position, blower cycles with demand or runs continuously while heating or cooling circuit cycles.
3. Depending on the type of indoor thermostat, blower and entire unit will be off when the system switch is in OFF position.

Temperature Rise (Figure 53)

Temperature rise for A93DF1E / 92G1DFE units depends on unit input, blower speed, blower horsepower and static pressure as marked on the unit rating plate. The blower speed must be set for unit operation within the range of "TEMP. RISE °F" listed on the unit rating plate.

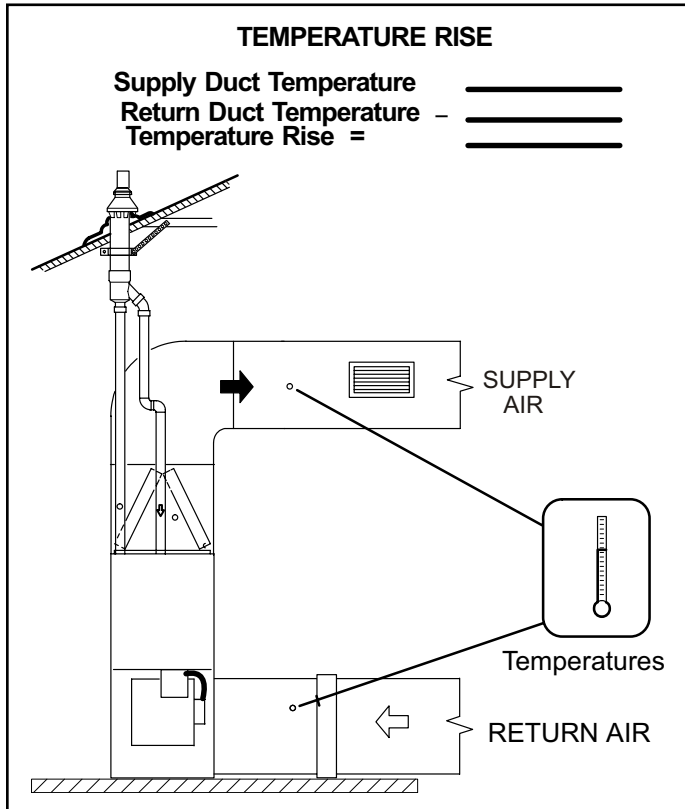

Figure 53.

External Static Pressure

1. Tap locations shown in Figure 54.
2. Punch a 1/4" diameter hole in supply and return air plenums. Insert manometer hose flush with inside edge of hole or insulation. Seal around the hose with permagum. Connect the zero end of the manometer to the discharge (supply) side of the system. On ducted systems, connect the other end of manometer to the return duct as above.
3. With only the blower motor running and the evaporator coil dry, observe the manometer reading. Adjust blower motor speed to deliver the air desired according to the job requirements. For heating speed external static pressure drop must not be more than 0.5" W.C. For cooling speed external static pressure drop must not be more than 0.8" W.C.
4. Seal the hole when the check is complete.

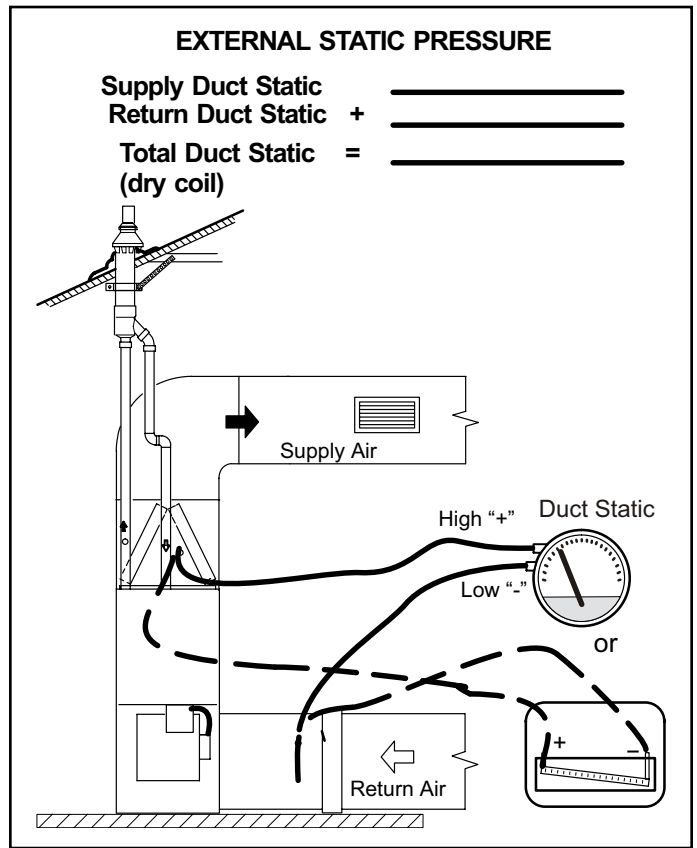

Figure 54.

Blower Speed Taps

Blower speed tap changes are made on the integrated control. See Figure 3 or Figure 52. The heating tap is connected to the "HEAT" terminal and the cooling tap is connected to the "COOL" terminal. On all units the continuous blower tap is connected to the "FAN" terminal. Unused taps must be secured on two dummy terminals labeled "PARK". To change out existing speed tap, turn off power and switch out speed tap with tap connected to "PARK". See blower speed tap table on unit diagram for motor tap colors for each speed.

Maintenance

⚠ WARNING

ELECTRICAL SHOCK, FIRE, OR EXPLOSION HAZARD.

Failure to follow safety warnings exactly could result in dangerous operation, serious injury, death or property damage.

Improper servicing could result in dangerous operation, serious injury, death, or property damage.

Before servicing, disconnect all electrical power to furnace.

When servicing controls, label all wires prior to disconnecting. Take care to reconnect wires correctly. Verify proper operation after servicing.

At the beginning of each heating season, system should be checked as follows by a qualified service technician:

Blower

Check the blower wheel for debris and clean if necessary. The blower motors are prelubricated for extended bearing life. No further lubrication is needed.

⚠ WARNING

The blower access panel must be securely in place when the blower and burners are operating. Gas fumes, which could contain carbon monoxide, can be drawn into living space resulting in personal injury or death.

Filters

All air filters are installed external to the unit. Filters should be inspected monthly. Clean or replace the filters when necessary to ensure proper furnace operation. Table 21 lists recommended filter sizes.

⚠ IMPORTANT

If a high-efficiency filter is being installed as part of this system to ensure better indoor air quality, the filter must be properly sized. High-efficiency filters have a higher static pressure drop than standard-efficiency glass/foam filters. If the pressure drop is too great, system capacity and performance may be reduced. The pressure drop may also cause the limit to trip more frequently during the winter and the indoor coil to freeze in the summer, resulting in an increase in the number of service calls.

Before using any filter with this system, check the specifications provided by the filter manufacturer

Furnace Cabinet Width	Filter Size
B (17-1/2")	16 x 25 x 1 (1)
C (21")	

Table 21.

Exhaust and Air Intake Pipes

Check the exhaust and air intake pipes and all connections for tightness and to make sure there is no blockage.

NOTE: After any heavy snow, ice or frozen fog event the furnace vent pipes may become restricted. Always check the vent system and remove any snow or ice that may be obstructing the plastic intake or exhaust pipes.

Electrical

⚠ WARNING

Fire Hazard. Use of aluminum wire with this product may result in a fire, causing property damage, severe injury or death. Use copper wire only with this product.

⚠ CAUTION

Failure to use properly sized wiring and circuit breaker may result in property damage. Size wiring and circuit breaker(s) per Product Specifications and unit rating plate.

1. Check all wiring for loose connections.
2. Check for the correct voltage at the furnace (furnace operating). Correct voltage is 120VAC + 10%
3. Check amp-draw using a true RMS meter on the blower motor with blower access panel in place. See Figure 55.

Unit Nameplate _____ Actual _____

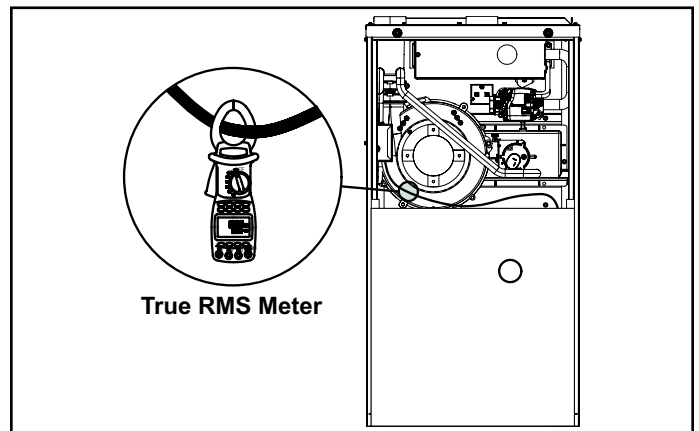

Figure 55. Check Motor Amp Draw

Winterizing and Condensate Trap Care

1. Turn off power to the furnace.
2. Have a shallow pan ready to empty condensate water.
3. Remove the clean out cap from the condensate trap and empty water. Inspect the trap then reinstall the clean out cap.

Condensate Hose Screens (Figure 56)

Check the condensate hose screens for blockage and clean if necessary.

1. Turn off power to the unit.
2. Remove hoses from cold end header box. Twist and pull screens to remove.
3. Inspect screens and rinse with tap water if needed.
4. Reinstall screens, reconnect hoses and turn on power to unit.

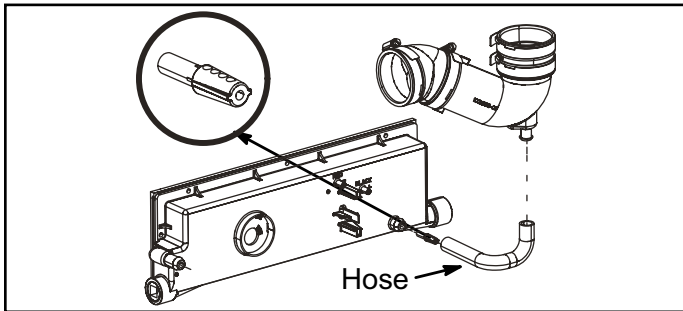

Figure 56. Condensate Hose Screens

Cleaning Heat Exchanger

If cleaning the heat exchanger becomes necessary, follow the below procedures and refer to Figure 1 when disassembling unit. Use papers or protective covering in front of furnace while removing heat exchanger assembly.

1. Turn off electrical and gas supplies to the furnace.
2. Remove the furnace access panels.
3. Disconnect the wires from the gas valve.
4. Remove gas supply line connected to gas valve. Remove the burner box cover (if equipped) and remove gas valve/manifold assembly.
5. Remove sensor wire from sensor. Disconnect 2-pin plug from the ignitor.
6. Disconnect wires from flame roll-out switches.
7. Loosen clamps at vent elbow. Disconnect condensate drain tubing from flue collar. and remove the vent elbow.
8. Loosen clamps and remove combustion air intake flexible connector if equipped.
9. Remove four burner box screws at the vestibule panel and remove burner box. Set burner box assembly aside.

NOTE: *If necessary, clean burners at this time. Follow procedures outlined in Burner Cleaning section.*

10. Mark and disconnect all combustion air pressure tubing from cold end header collector box.
11. Mark and remove wires from pressure switch assembly. Remove pressure switch assembly. Keep tubing attached to pressure switch assembly.
12. Disconnect the plug from the combustion air inducer. Remove two screws which secure combustion air inducer to collector box. Remove combustion air inducer assembly. Remove ground wire from vest panel.
13. Remove electrical junction box from the side of the furnace.
14. Disconnect condensate line from cold end header box. Remove cold end header box.
15. Loosen clamps on exhaust and air intake pipe seal plate. Slide exhaust and intake pipes up and out to clear blower deck. Remove exhaust and air intake pipe seal plate.
16. Mark and disconnect any remaining wiring to heating compartment components. Disengage strain relief bushing and pull wiring and bushing through the hole in the blower deck.
17. Remove the primary limit from the vestibule panel.
18. Remove two screws from the front cabinet flange at the blower deck. Spread cabinet sides slightly to allow clearance for removal of heat exchanger.
19. Remove screws along vestibule sides which secure vestibule panel and heat exchanger assembly to cabinet. Remove two screws from blower rail which secure top heat exchanger flange. Remove heat exchanger from furnace cabinet.
20. Back wash heat exchanger with soapy water solution or steam. If steam is used it must be below 275°F (135°C).
21. Thoroughly rinse and drain the heat exchanger. Soap solutions can be corrosive. Take care to rinse entire assembly.
22. Reinstall heat exchanger into cabinet making sure that the clamshells of the heat exchanger assembly are engaged properly into the support bracket on the blower deck. Remove the indoor blower to view this area through the blower opening.
23. Re-secure the supporting screws along the vestibule sides and top to the cabinet.
24. Reinstall cabinet screws on front flange at blower deck.
25. Reinstall the primary limit on the vestibule panel.
26. Route heating component wiring through hole in blower deck and reinsert strain relief bushing.
27. Reinstall electrical junction box.
28. Reinstall exhaust and air intake pipe seal plate. Reinstall exhaust and air intake pipes and tighten clamps on pipe seal plate.

29. Reinstall the cold end header box.
30. Reinstall the combustion air inducer. Reconnect the combustion air inducer to the wire harness.
31. Reinstall pressure switch assembly and reconnect pressure switch wiring.
32. Carefully connect combustion air pressure switch tubing from pressure switches to proper ports on cold end header collector box.
33. Reinstall condensate trap.
34. Secure burner box assembly to vestibule panel using four existing screws. Make sure burners line up in center of burner ports.
35. Reconnect exhaust piping and exhaust drain tubing.
36. Reconnect flame roll-out switch wires.
37. Reconnect sensor wire and reconnect 2-pin plug from ignitor.
38. Reinstall gas valve manifold assembly. Reconnect gas supply line to gas valve.
39. Reinstall burner box cover if equipped.
40. Reconnect plug to gas valve.
41. Replace the blower compartment access panel.
42. Follow lighting instructions on unit nameplate to light and operate furnace for 5 minutes to ensure the furnace is operating properly.
43. Check all piping connections, factory and field, for gas leaks. Use a leak detecting solution or other preferred means.

 **CAUTION**

Some soaps used for leak detection are corrosive to certain metals. Carefully rinse piping thoroughly after leak test has been completed. Do not use matches, candles, flame or other sources of ignition to check for gas leaks.

44. Replace access panel.

Cleaning the Burner Assembly (if needed)

1. Turn off electrical and gas power supplies to furnace. Remove upper and lower furnace access panels.
2. Disconnect the 2-pin plug from the gas valve.
3. Remove the burner box cover (if equipped).
4. Disconnect the gas supply line from the gas valve. Remove gas valve/manifold assembly.
5. Loosen clamps and remove combustion air intake flexible connector (if equipped).
6. Mark and disconnect sensor wire from the sensor. Disconnect plug from the ignitor at the burner box.
7. Remove four screws which secure burner box assembly to vest panel. Remove burner box from the unit.
8. Use the soft brush attachment on a vacuum cleaner to gently clean the face of the burners. Visually inspect the inside of the burners and crossovers for any blockage caused by foreign matter. Remove any blockage.
9. Reinstall the burner box assembly using the existing four screws. Make sure that the burners line up in the center of the burner ports.
10. Reconnect the sensor wire and reconnect the 2-pin plug to the ignitor wiring harness.
11. Reinstall combustion air intake flexible connector (if equipped), secure using existing clamps.
12. Reinstall the gas valve manifold assembly. Reconnect the gas supply line to the gas valve. Reinstall the burner box cover.
13. Reconnect plug to gas valve.
14. Replace the blower compartment access panel.
15. Refer to instruction on verifying gas and electrical connections when re-establishing supplies.
16. Follow lighting instructions to light and operate furnace for 5 minutes to ensure that heat exchanger is clean and dry and that furnace is operating properly.
17. Replace access panel.

Wiring Diagram

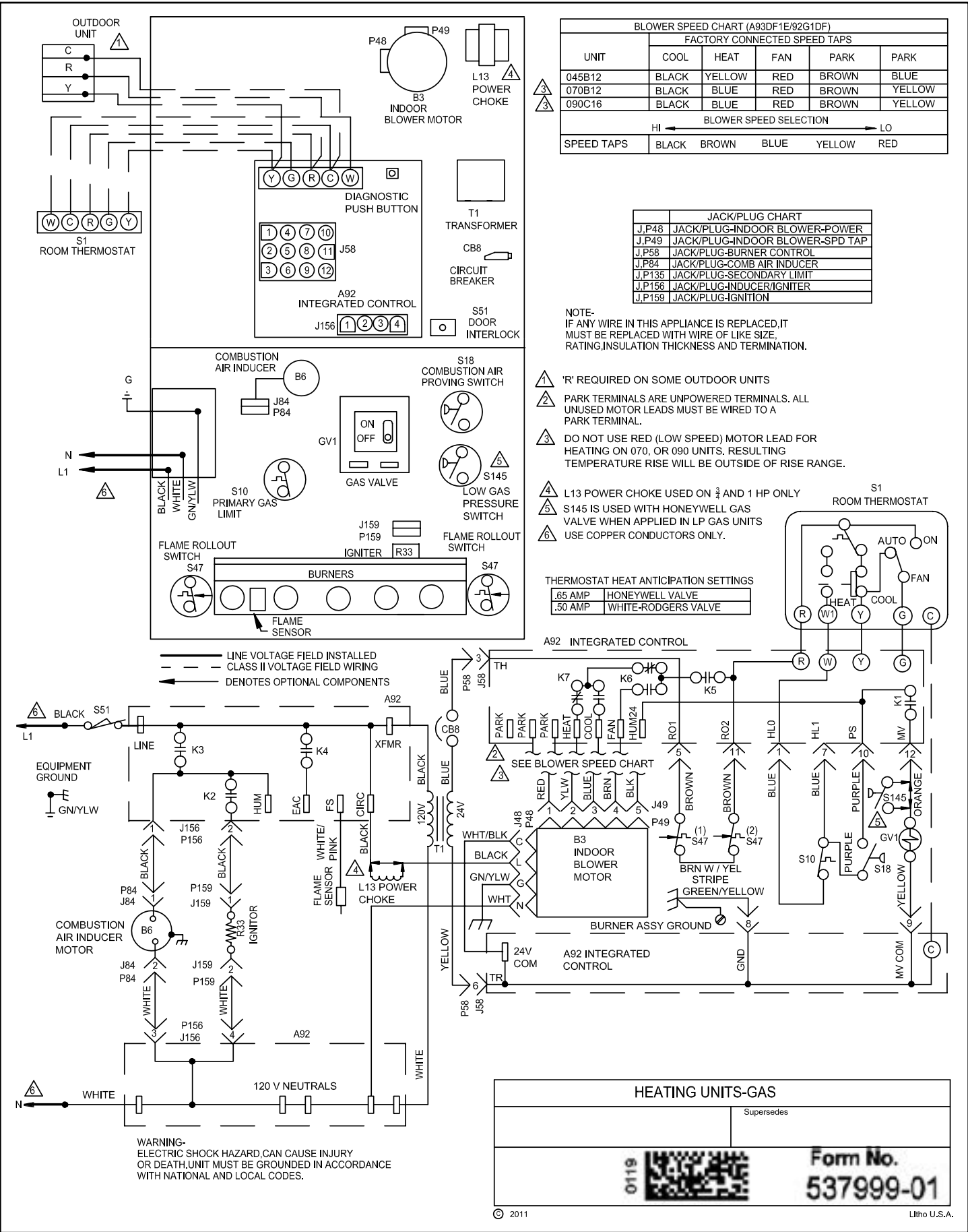

BLOWER SPEED CHART (A93DF1E/92G1DF)

UNIT	FACTORY CONNECTED SPEED TAPS				
	COOL	HEAT	FAN	PARK	PARK
045B12	BLACK	YELLOW	RED	BROWN	BLUE
070B12	BLACK	BLUE	RED	BROWN	YELLOW
090C16	BLACK	BLUE	RED	BROWN	YELLOW

HI ← BLOWER SPEED SELECTION → LO

SPEED TAPS	BLACK	BROWN	BLUE	YELLOW	RED
------------	-------	-------	------	--------	-----

JACK/PLUG CHART

J.P48	JACK/PLUG-INDOOR BLOWER-POWER
J.P49	JACK/PLUG-INDOOR BLOWER-SPD TAP
J.P58	JACK/PLUG-BURNER CONTROL
J.P84	JACK/PLUG-COMB AIR INDUCER
J.P135	JACK/PLUG-SECONDARY LIMIT
J.P156	JACK/PLUG-INDUCER/IGNITER
J.P159	JACK/PLUG-IGNITION

NOTE-
 IF ANY WIRE IN THIS APPLIANCE IS REPLACED, IT MUST BE REPLACED WITH WIRE OF LIKE SIZE, RATING, INSULATION THICKNESS AND TERMINATION.

- ⚠ 'R' REQUIRED ON SOME OUTDOOR UNITS
- ⚠ PARK TERMINALS ARE UNPOWERED TERMINALS. ALL UNUSED MOTOR LEADS MUST BE WIRED TO A PARK TERMINAL.
- ⚠ DO NOT USE RED (LOW SPEED) MOTOR LEAD FOR HEATING ON 070, OR 090 UNITS. RESULTING TEMPERATURE RISE WILL BE OUTSIDE OF RISE RANGE.

- ⚠ L13 POWER CHOKE USED ON ¾ AND 1 HP ONLY
- ⚠ S145 IS USED WITH HONEYWELL GAS VALVE WHEN APPLIED IN LP GAS UNITS
- ⚠ USE COPPER CONDUCTORS ONLY.

THERMOSTAT HEAT ANTICIPATION SETTINGS

.65 AMP	HONEYWELL VALVE
.50 AMP	WHITE-RODGERS VALVE

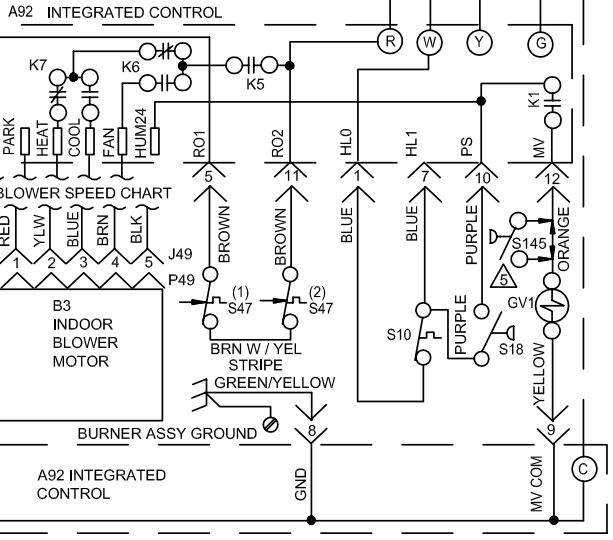
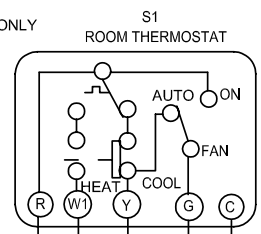

HEATING UNITS-GAS

Supersedes

0119
Form No.
537999-01

Litho U.S.A.

Troubleshooting: Heating Sequence of Operation

HEATING SEQUENCE OF OPERATION

NORMAL HEATING MODE

ABNORMAL HEATING MODE

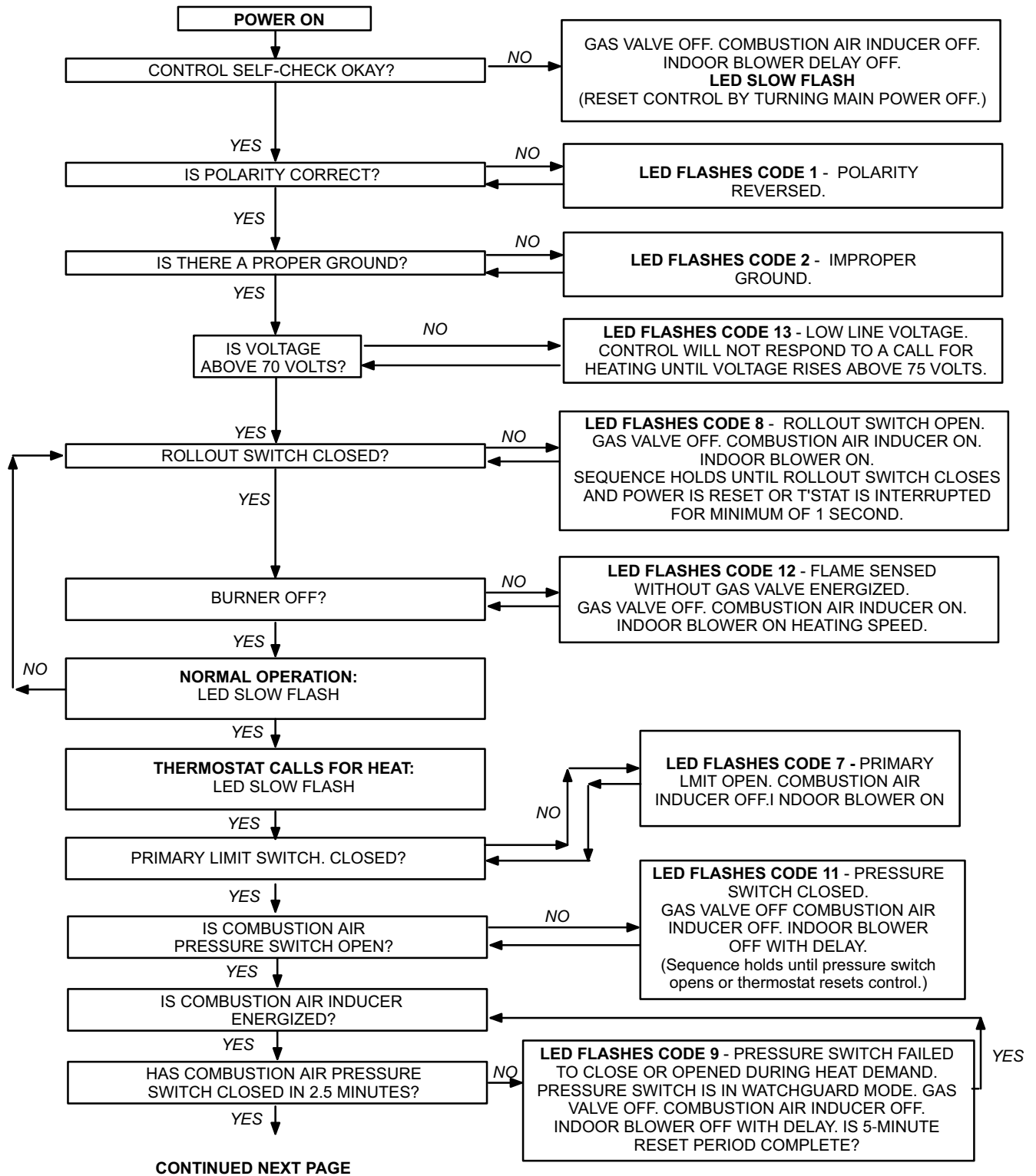

Troubleshooting: Heating Sequence of Operation (Continued)

HEATING SEQUENCE CONTINUED

NORMAL HEATING MODE

ABNORMAL HEATING MODE

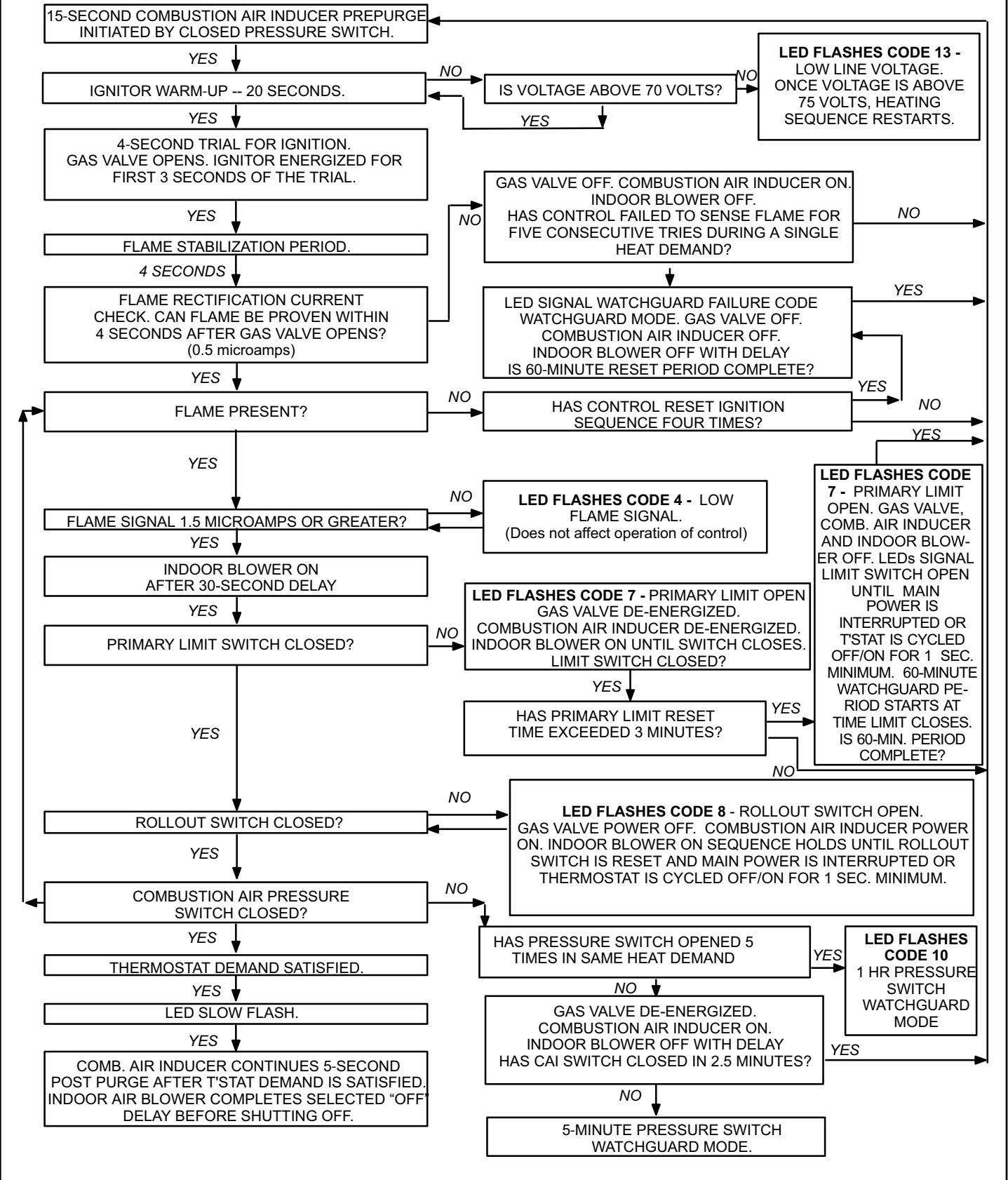

Troubleshooting: Cooling Sequence of Operation

COOLING SEQUENCE OF OPERATION

NORMAL COOLING MODE

ABNORMAL COOLING MODE

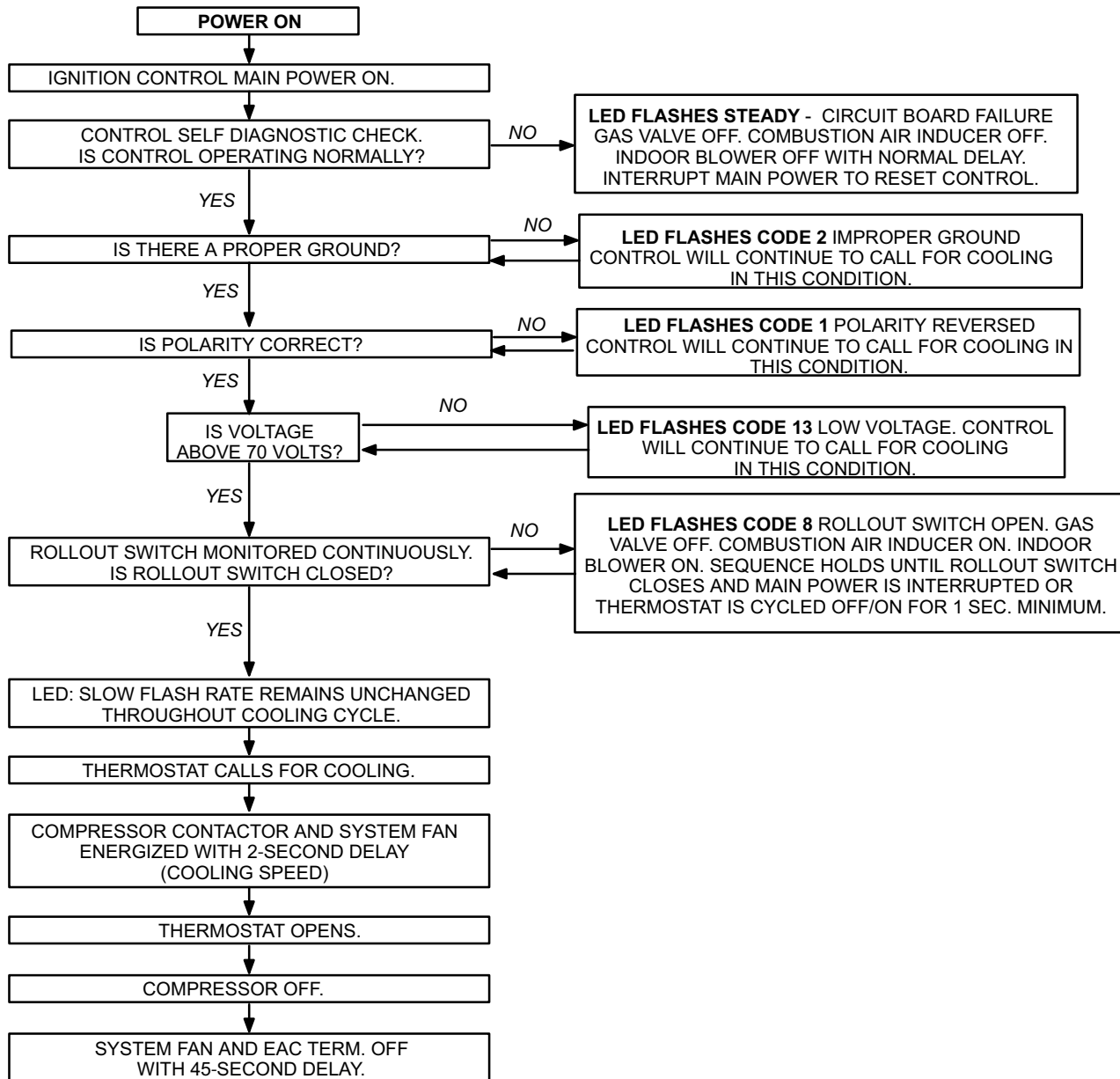

Troubleshooting: Continuous Fan / Accessories Sequence of Operation

CONTINUOUS FAN / ACCESSORIES SEQUENCE OF OPERATION

