

INSTALLATION INSTRUCTIONS

95G1UHEX

Warm Air Gas Furnace

Upflow / Horizontal Left and Right Air Discharge

This manual must be left with the homeowner for future reference.



This is a safety alert symbol and should never be ignored. When you see this symbol on labels or in manuals, be alert to the potential for personal injury or death.

Table of Contents

Unit Dimensions	2	Gas Piping	36
95G1UHEX Gas Furnace	3	Electrical	39
Shipping and Packing List	3	Blower Performance	42
General	5	Unit Start-Up	45
Combustion, Dilution & Ventilation Air	6	Gas Pressure Adjustment	46
Installation - Setting Equipment	9	Testing for Proper Venting and Sufficient Combustion Air for Non-Direct Vent Applications	47
Filters	12	Proper Combustion	47
Duct System	12	High Altitude Information	47
Pipe & Fittings Specifications	13	Other Unit Adjustments	48
Joint Cementing Procedure	14	Service	49
Venting Practices	16	Repair Parts List	50
Vent Piping Guidelines	17		
Condensate Piping	32		

WARNING

Improper installation, adjustment, alteration, service or maintenance can cause property damage, personal injury or loss of life. Installation and service must be performed by a licensed professional HVAC installer (or equivalent), service agency or the gas supplier.

CAUTION

As with any mechanical equipment, personal injury can result from contact with sharp sheet metal edges. Be careful when you handle this equipment.

Manufactured By
Allied Air Enterprises LLC
A Lennox International, Inc. Company
215 Metropolitan Drive
West Columbia, SC 29170



(P) 507762-04

Save these instructions for future reference

Unit Dimensions

¹ **NOTE** - 60C size units that require second stage air volumes over 1800 cfm must have one of the following:

1. Single side return air with transition, to accommodate 20 x 25 x 1 in. (508 x 635 x 25 mm) air filter.
2. Single side return air with optional RAB Return Air Base
3. Bottom return air.
4. Return air from both sides.
5. Bottom and one side return air.

² Optional External Side Return Air Filter kit is not for use with optional Return Air Base.

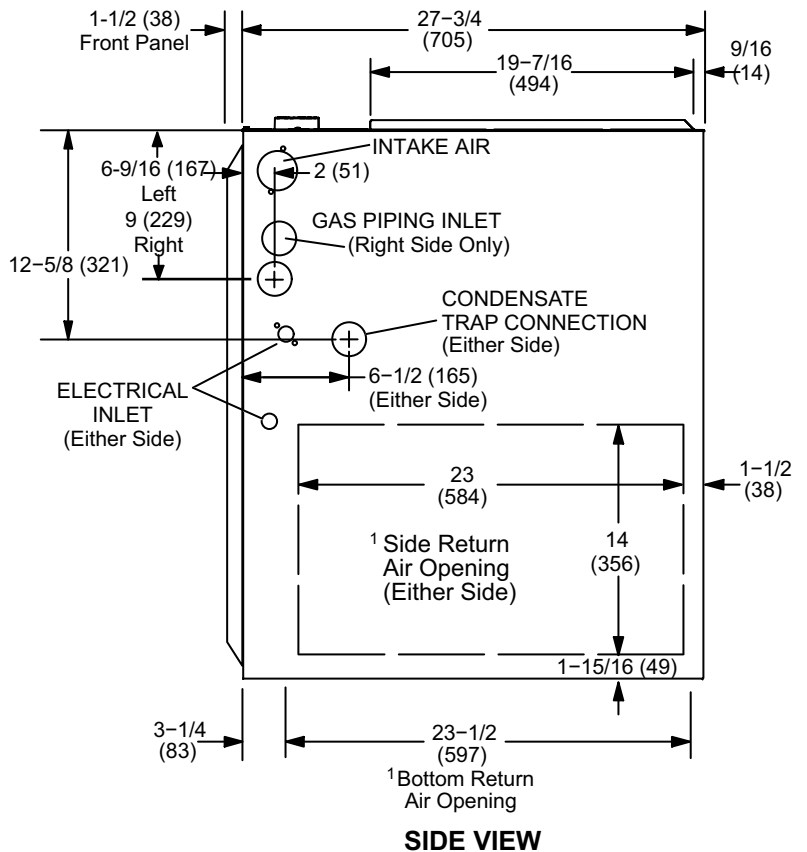
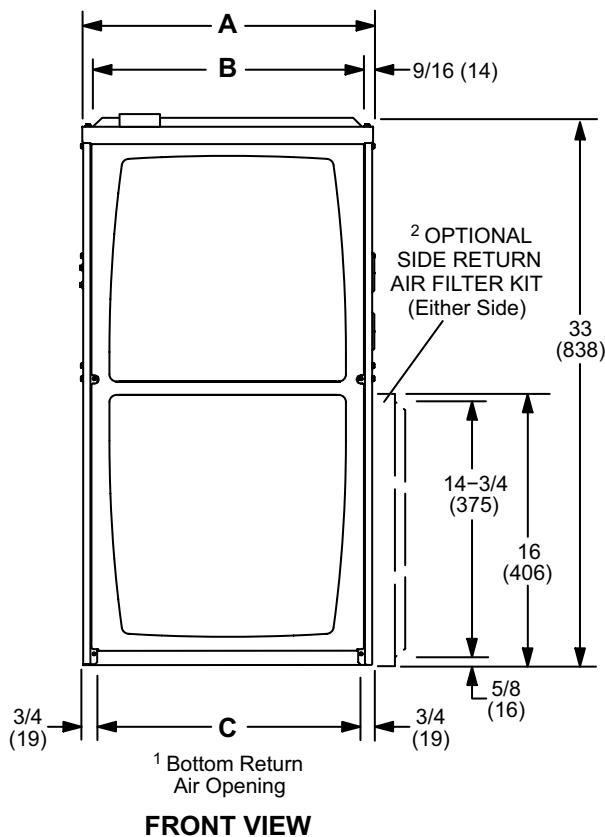
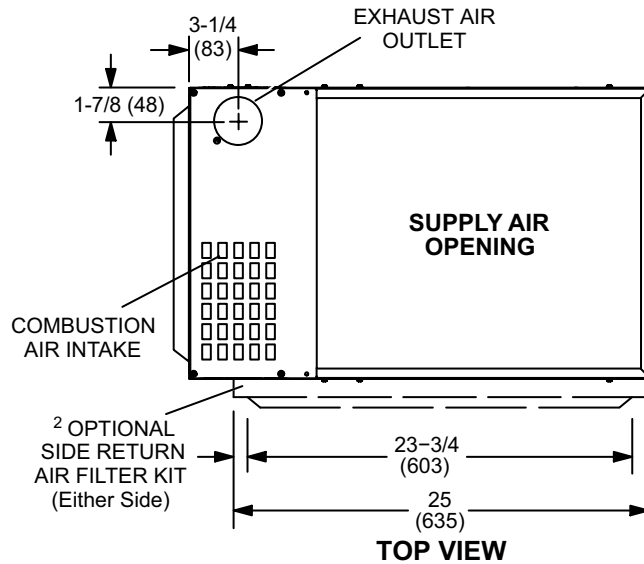

Model	A		B		C	
	in.	mm	in.	mm	in.	mm
95G1UH040BE12X 95G1UH060BE12X	17-1/2	446	16-3/8	416	16	406
95G1UH080CE16X 95G1UH100CE20X	21	553	19-7/8	505	19-1/2	495

95G1UHEX Gas Furnace

The 95G1UHEX Category IV gas furnace is shipped ready for installation in the upflow or horizontal position. The furnace is shipped with the bottom panel in place. The bottom panel must be removed if the unit is to be installed in horizontal or upflow applications with bottom return air.

The 95G1UHEX can be installed as either a Direct Vent or a Non-Direct Vent gas central furnace.

The furnace is equipped for installation in natural gas applications.

NOTE: *In Direct Vent installations, combustion air is taken from outdoors and flue gases are discharged outdoors. In Non-Direct Vent installations, combustion air is taken from indoors or ventilated attic or crawlspace and flue gases are discharged outdoors. See Figure 1 and Figure 2 for applications involving roof termination.*

Shipping and Packing List

Package 1 of 1 contains

- 1 - Assembled 95G1UHEX unit
- 1 - Bag assembly containing the following:
 - 1 - Snap bushing
 - 1 - 1/2" diameter threaded street elbow
 - 1 - Snap plug
 - 1 - Wire tie
 - 1 - Condensate trap
 - 1 - Condensate trap cap
 - 1 - Condensate trap clamp
 - 1 - 2" diameter debris screen
 - 1 - 3/4" Threaded street elbow

Check equipment for shipping damage. If you find any damage, immediately contact the last carrier.

The following items may also be ordered separately:

- 1 - Thermostat
- 1 - Return air base kit
- 1 - Horizontal suspension kit

⚠ WARNING

Improper installation, adjustment, alteration, service or maintenance can cause property damage, personal injury or loss of life. Installation and service must be performed by a licensed professional installer (or equivalent), service agency or the gas supplier.

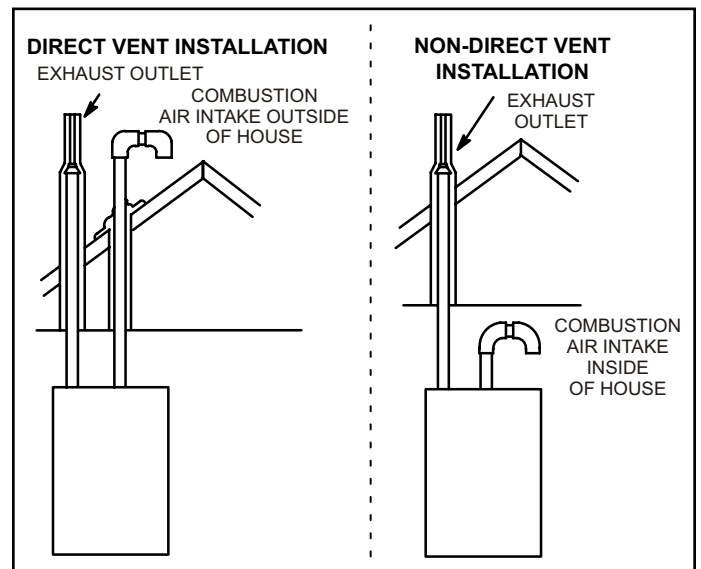

Figure 1.

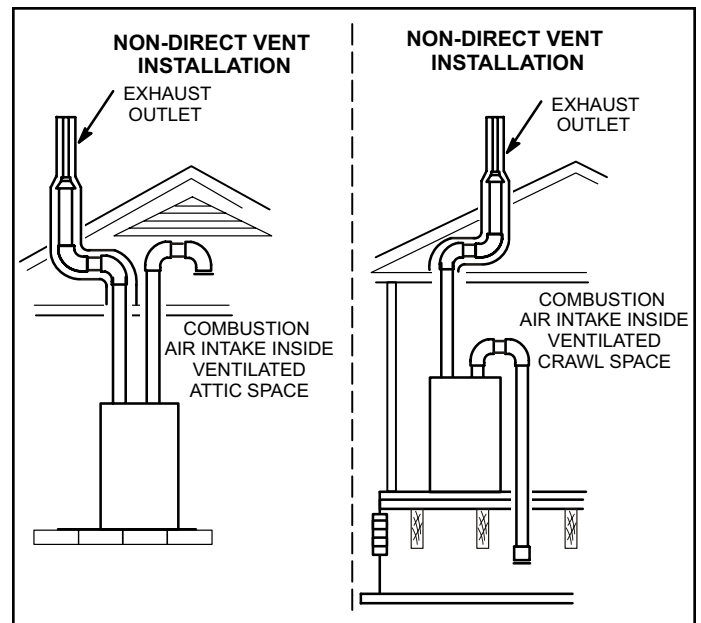

Figure 2.

⚠ CAUTION

As with any mechanical equipment, personal injury can result from contact with sharp sheet metal edges. Be careful when you handle this equipment.

Use only the type of gas approved for use with this furnace. Refer to unit nameplate. 95G1UHEX units are CSA International certified to ANSI Z21.47 and CSA 2.3 standards.

Building Codes

In the USA, installation of gas furnaces must conform with local building codes. In the absence of local codes, units must be installed according to the current National Fuel Gas Code (ANSI-Z223.1/NFPA 54). The National Fuel Gas Code is available from the following address:

American National Standards Institute, Inc.
11 West 42nd Street
New York, NY 10036

In Canada, installation must conform with current National Standard of Canada CSA-B149 Natural Gas and Propane Installation Codes, local plumbing or waste water codes and other applicable local codes.

In order to ensure proper unit operation in non-direct vent applications, combustion and ventilation air supply must be provided according to the current National Fuel Gas Code or CSA-B149 standard.

Installation Locations

This furnace is CSA International certified for installation clearances to combustibles as listed on the unit nameplate and in the table in Figure 11. Accessibility and service clearances must take precedence over fire protection clearances.

NOTE: For installation on combustible floors, the furnace shall not be installed directly on carpeting, tile, or other combustible material other than wood flooring.

For installation in a residential garage, the furnace must be installed so that the burner(s) and the ignition source are located no less than 18 inches (457 mm) above the floor. The furnace must be located or protected to avoid physical damage by vehicles. When a furnace is installed in a public garage, hangar, or other building that has a hazardous atmosphere, the furnace must be installed according to recommended good practice requirements and current National Fuel Gas Code or CSA B149 standards.

NOTE: Furnace must be adjusted to obtain a temperature rise within the range specified on the unit nameplate. Failure to do so may cause erratic limit operation and premature heat exchanger failure.

This 95G1UHEX furnace must be installed so that its electrical components are protected from water.

Installed in Combination with a Cooling Coil

When this furnace is used with cooling coils (Figure 3), it shall be installed in parallel with, or on the upstream side of, cooling coils to avoid condensation in the heating compartment. With a parallel flow arrangement, a damper (or other means to control the flow of air) must adequately

prevent chilled air from entering the furnace. If the damper is manually operated, it must be equipped to prevent operation of either the heating or the cooling unit, unless it is in the full HEAT or COOL setting.

When installed, this furnace must be electrically grounded according to local codes. In addition, in the United States, installation must conform with the current National Electric Code, ANSI/NFPA No. 70. The National Electric Code (ANSI/NFPA No. 70) is available from the following address:

National Fire Protection Association
1 Battery March Park
Quincy, MA 02269

In Canada, all electrical wiring and grounding for the unit must be installed according to the current regulations of the Canadian Electrical Code Part I (CSA Standard C22.1) and/or local codes.

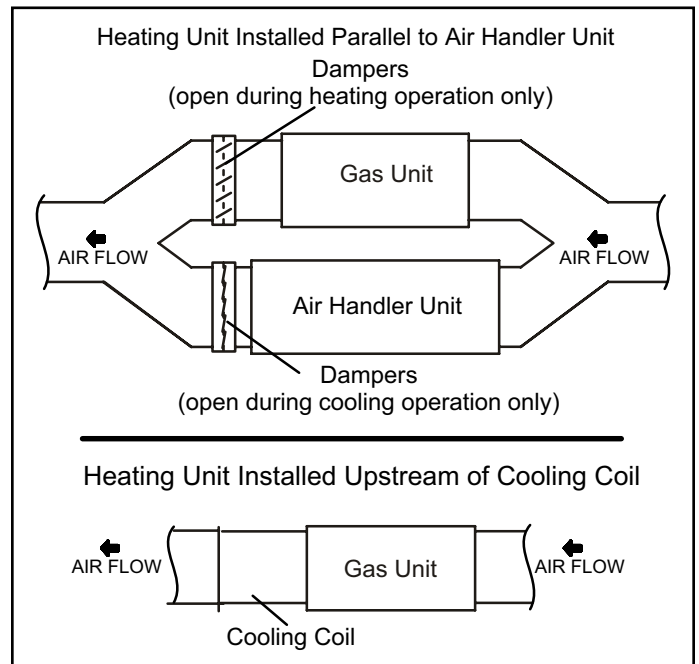

Figure 3.

NOTE: This furnace is designed for a minimum continuous return air temperature of 60°F (16°C) or an intermittent operation down to 55°F (13°C) dry bulb for cases where a night setback thermostat is used. Return air temperature must not exceed 85°F (29°C) dry bulb.

The 95G1UHEX furnace may be installed in alcoves, closets, attics, basements, garages, crawl spaces and utility rooms in the upflow or horizontal position.

This furnace design has not been CSA certified for installation in mobile homes, recreational vehicles, or outdoors.

Use of Furnace as a Construction Heater

Units may be used for heating of buildings or structures under construction, if the following conditions are met to ensure proper operation.

DO NOT USE THE UNIT FOR CONSTRUCTION HEAT UNLESS ALL OF THE FOLLOWING CRITERIA ARE MET:

- a. Furnace must be in its final location. The vent system must be permanently installed per these installation instructions.
- b. Furnace must be installed as a two pipe system and one hundred percent (100%) outdoor air must be provided for combustion air requirements during construction.
- c. A room thermostat must control the furnace. The use of fixed jumpers that will provide continuous heating is prohibited.
- d. The input rate and temperature rise must be set per the furnace rating plate.
- e. Supply and Return air ducts must be provided and sealed to the furnace. Return air must be terminated outside of the space where furnace is installed.
- f. Return air temperature range between 60°F (16°C) and 80°F (27°C) must be maintained.
- g. MERV 11 or greater air filters must be installed in the system and must be regularly inspected and maintained (e.g., regular static checks and replaced at end of life) during construction.
- h. Blower and vestibule access panels must be in place on the furnace at all times.
- i. The furnace heat exchanger, components, duct system, and evaporator coils must be thoroughly cleaned following final construction clean-up.
- j. Air filters must be replaced upon construction completion.
- k. All furnace operating conditions (including ignition, input rate, temperature rise and venting) must be verified in accordance with these installation instructions.

EQUIPMENT MAY EXPERIENCE PREMATURE COMPONENT FAILURE AS A RESULT OF FAILURE TO FOLLOW THE ABOVE INSTALLATION INSTRUCTIONS. FAILURE TO FOLLOW THE ABOVE INSTALLATION INSTRUCTIONS VOIDS THE MANUFACTURER'S EQUIPMENT LIMITED WARRANTY. ALLIED AIR DISCLAIMS ALL LIABILITY IN CONNECTION WITH INSTALLER'S FAILURE TO FOLLOW THE ABOVE INSTALLATION INSTRUCTIONS.

NOTWITHSTANDING THE FOREGOING, INSTALLER IS RESPONSIBLE FOR CONFIRMING THAT THE USE OF CONSTRUCTION HEAT IS CONSISTENT WITH THE POLICIES AND CODES OF ALL REGULATING ENTITIES. ALL SUCH POLICIES AND CODES MUST BE ADHERED TO.

General

These instructions are intended as a general guide and do not supersede local codes in any way. Consult authorities having jurisdiction before installation.

In addition to the requirements outlined previously, the following general recommendations must be considered when installing a 95G1UHEX furnace:

- Place the furnace as close to the center of the air distribution system as possible. The furnace should also be located close to the vent termination point.
- When the furnace is installed in non-direct vent applications, do not install the furnace where drafts might blow directly into it. This could cause improper combustion and unsafe operation.
- When the furnace is installed in non-direct vent applications, do not block the furnace combustion air opening with clothing, boxes, doors, etc. Air is needed for proper combustion and safe unit operation.
- When the furnace is installed in an attic or other insulated space, keep insulation away from the furnace.
- When the furnace is installed in an unconditioned space, consider provisions required to prevent freezing of condensate drain system.
- Please consult the manufacturer of your evaporator coil for their recommendations on distance required between the heat exchanger and their drain pan. Adequate space must be provided between the drain pan and the furnace heat exchanger.

CAUTION

95G1UHEX unit should not be installed in areas normally subject to freezing temperatures.

WARNING

Insufficient combustion air can cause headaches, nausea, dizziness or asphyxiation. It will also cause excess water in the heat exchanger resulting in rusting and premature heat exchanger failure. Excessive exposure to contaminated combustion air will result in safety and performance related problems. Avoid exposure to the following substances in the combustion air supply:

- Permanent wave solutions
- Chlorinated waxes and cleaners
- Chlorine base swimming pool chemicals
- Water softening chemicals
- De-icing salts or chemicals
- Carbon tetrachloride
- Halogen type refrigerants
- Cleaning solvents (such as perchloroethylene)
- Printing inks, paint removers, varnishes, etc.
- Hydrochloric acid
- Cements and glues
- Antistatic fabric softeners for clothes dryers
- Masonry acid washing materials

Combustion, Dilution & Ventilation Air

If the 95G1UHEX is installed as a Non-Direct Vent Furnace, follow the guidelines in this section.

NOTE: *In Non-Direct Vent installations, combustion air is taken from indoors or ventilated attic or crawlspace and flue gases are discharged outdoors.*

In the past, there was no problem in bringing in sufficient outdoor air for combustion. Infiltration provided all the air that was needed. In today's homes, tight construction practices make it necessary to bring in air from outside for combustion. Take into account that exhaust fans, appliance vents, chimneys, and fireplaces force additional air that could be used for combustion out of the house.

Unless outside air is brought into the house for combustion, negative pressure (outside pressure is greater than inside pressure) will build to the point that a downdraft can occur in the furnace vent pipe or chimney. As a result, combustion gases enter the living space creating a potentially dangerous situation.

In the absence of local codes concerning air for combustion and ventilation, use the guidelines and procedures in this section to install 95G1UHEX furnaces to ensure efficient and safe operation. You must consider combustion air

needs and requirements for exhaust vents and gas piping. A portion of this information has been reprinted with permission from the National Fuel Gas Code (ANSI-Z223.1/NFPA 54). This reprinted material is not the complete and official position of the ANSI on the referenced subject, which is represented only by the standard in its entirety.

In Canada, refer to the CSA B149 installation codes.

CAUTION

Do not install the furnace in a corrosive or contaminated atmosphere. Meet all combustion and ventilation air requirements, as well as all local codes.

All gas-fired appliances require air for the combustion process. If sufficient combustion air is not available, the furnace or other appliance will operate inefficiently and unsafely. Enough air must be provided to meet the needs of all fuel-burning appliances and appliances such as exhaust fans which force air out of the house. When fireplaces, exhaust fans, or clothes dryers are used at the same time as the furnace, much more air is required to ensure proper combustion and to prevent a downdraft. Insufficient air causes incomplete combustion which can result in carbon monoxide.

In addition to providing combustion air, fresh outdoor air dilutes contaminants in the indoor air. These contaminants may include bleaches, adhesives, detergents, solvents and other contaminants which can corrode furnace components.

The requirements for providing air for combustion and ventilation depend largely on whether the furnace is installed in an unconfined or a confined space.

Unconfined Space

An unconfined space is an area such as a basement or large equipment room with a volume greater than 50 cubic feet (1.42 m³) per 1,000 Btu (.29 kW) per hour of the combined input rating of all appliances installed in that space. This space also includes adjacent rooms which are not separated by a door. Though an area may appear to be unconfined, it might be necessary to bring in outdoor air for combustion if the structure does not provide enough air by infiltration. If the furnace is located in a building of tight construction with weather stripping and caulking around the windows and doors, follow the procedures in the Air from Outside section.

Confined Space

A confined space is an area with a volume less than 50 cubic feet (1.42 m³) per 1,000 Btu (.29 kW) per hour of the combined input rating of all appliances installed in that space. This definition includes furnace closets or small equipment rooms. When the furnace is installed so that supply ducts carry air circulated by the furnace to areas

outside the space containing the furnace, the return air must be handled by ducts which are sealed to the furnace casing and which terminate outside the space containing the furnace. This is especially important when the furnace is mounted on a platform in a confined space such as a closet or small equipment room.

Even a small leak around the base of the unit at the platform or at the return air duct connection can cause a potentially dangerous negative pressure condition. Air for combustion and ventilation can be brought into the confined space either from inside the building or from outside.

Air from Inside

If the confined space that houses the furnace adjoins a space categorized as unconfined, air can be brought in by providing two permanent openings between the two spaces. Each opening must have a minimum free area of 1 square inch (645 mm²) per 1,000 Btu (.29 kW) per hour of total input rating of all gas-fired equipment in the confined space. Each opening must be at least 100 square inches (64516 mm²). One opening shall be within 12 inches (305 mm) of the top of the enclosure and one opening within 12 inches (305 mm) of the bottom. See Figure 4.

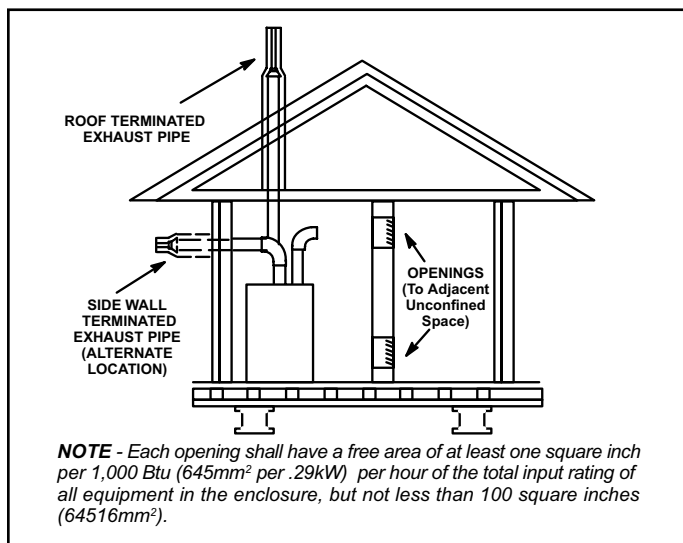

Figure 4. Equipment in Confined Space - All Air from Inside

Air from Outside

If air from outside is brought in for combustion and ventilation, the confined space must have two permanent openings. One opening shall be within 12 inches (305 mm) of the top of the enclosure and one opening within 12 inches (305 mm) of the bottom. These openings must communicate directly or by ducts with the outdoors or spaces (crawl or attic) that freely communicate with the outdoors or indirectly through vertical ducts. Each opening shall have a minimum free area of 1 square inch (645 mm²) per 4,000 Btu (1.17 kW) per hour of total input rating of all equipment in the enclosure. See Figure 5 and Figure 8. When communicating with the outdoors through horizontal

ducts, each opening shall have a minimum free area of 1 square inch (645 mm²) per 2,000 Btu (.56 kW) per total input rating of all equipment in the enclosure. See Figure 9.

When ducts are used, they shall be of the same cross-sectional area as the free area of the openings to which they connect. The minimum dimension of rectangular air ducts shall be no less than 3 inches (75 mm). In calculating free area, the blocking effect of louvers, grilles, or screens must be considered. If the design and free area of protective covering is not known for calculating the size opening required, it may be assumed that wood louvers will have 20 to 25 percent free area and metal louvers and grilles will have 60 to 75 percent free area. Louvers and grilles must be fixed in the open position or interlocked with the equipment so that they are opened automatically during equipment operation.

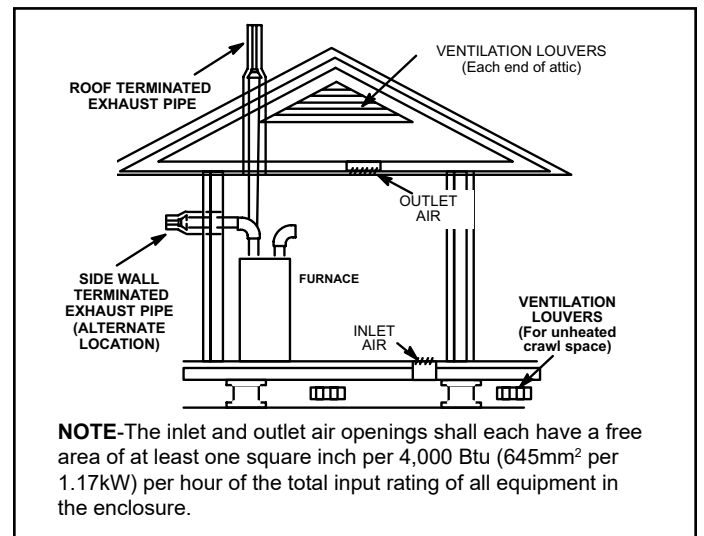

Figure 5. Equipment in Confined Space - All Air from Outlet (Inlet Air from Crawl Space and Outlet Air to Ventilated Attic)

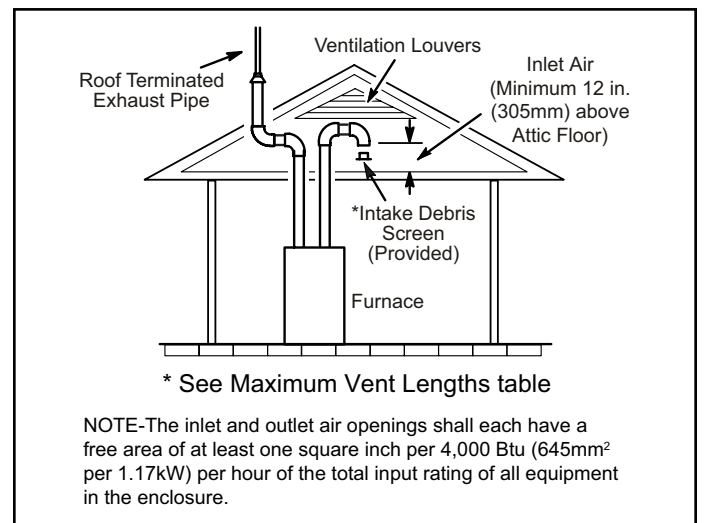

Figure 6. Equipment in Confined Space (Inlet Air from Ventilated Attic and Outlet Air to Outside)

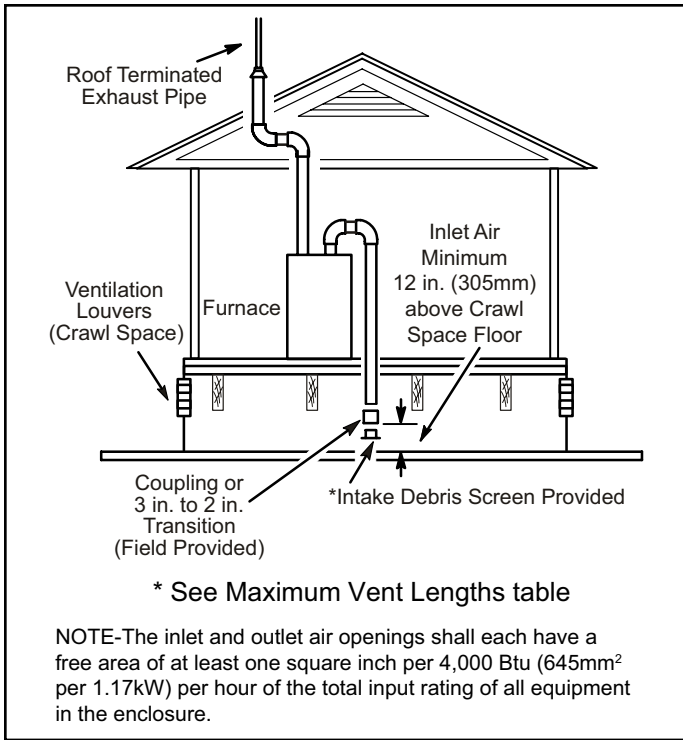

Figure 7. Equipment in Confined Space (Inlet Air from Ventilated Crawlspace and Outlet Air to Outside)

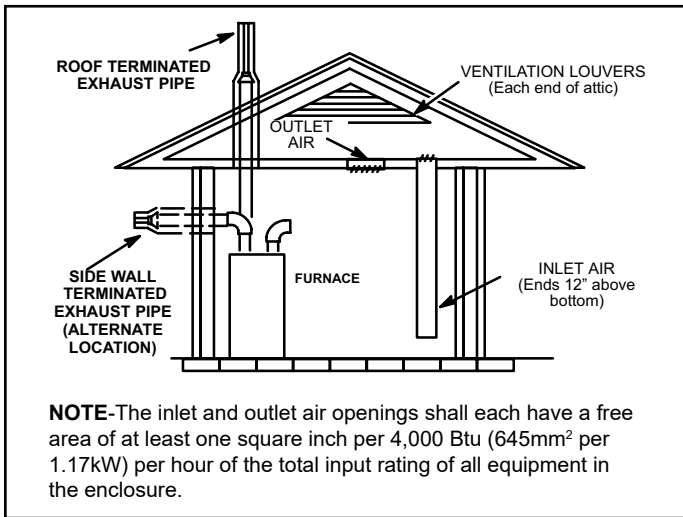

Figure 8. Equipment in Confined Space (All Air through Ventilated Attic)

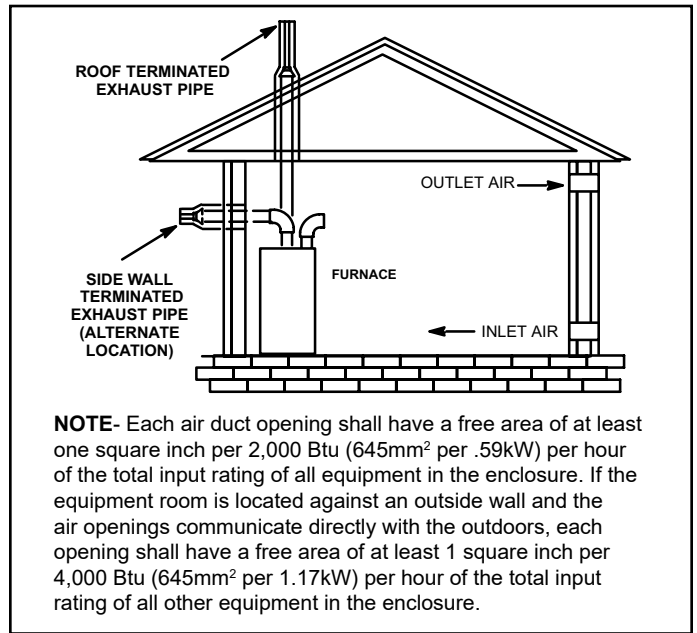

Figure 9. Equipment in Confined Space - All Air from Outside

Shipping Bolt Removal

Units with 1/2 and 3/4 hp blower motor are equipped with three flexible legs and one rigid leg. The rigid leg is equipped with a shipping bolt and a flat white plastic washer (rather than the rubber mounting grommet used with a flexible mounting leg). See Figure 10. The bolt and washer must be removed before the furnace is placed into operation. After the bolt and washer have been removed, the rigid leg will not touch the blower housing.

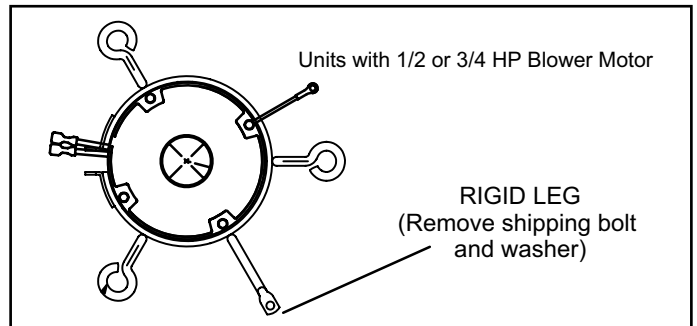

Figure 10. Shipping Bolt Removal

Installation - Setting Equipment

WARNING

Do not connect the return air duct to the back of the furnace. Doing so will adversely affect the operation of the safety control devices, which could result in personal injury or death.

WARNING

Blower access panel must be securely in place when blower and burners are operating. Gas fumes, which could contain carbon monoxide, can be drawn into living space resulting in personal injury or death.

Upflow Applications

The 95G1UHEX gas furnace can be installed as shipped in the upflow position. Refer to Figure 11 for clearances. Select a location that allows for the required clearances that are listed on the unit nameplate. Also consider gas supply connections, electrical supply, vent connection, condensate trap and drain connections, and installation and service clearances [24 inches (610 mm) at unit front]. The unit must be level from side to side. The unit may be positioned from level to 1/2" toward the front. See Figure 12.

Allow for clearances to combustible materials as indicated on the unit nameplate.

WARNING

Improper installation of the furnace can result in personal injury or death. Combustion and flue products must never be allowed to enter the return air system or air in the living space. Use sheet metal screws and joint tape to seal return air system to furnace.

In platform installations with furnace return, the furnace should be sealed airtight to the return air plenum. A door must never be used as a portion of the return air duct system. The base must provide a stable support and an airtight seal to the furnace. Allow absolutely no sagging, cracks, gaps, etc.

For no reason should return and supply air duct systems ever be connected to or from other heating devices such as a fireplace or stove, etc. Fire, explosion, carbon monoxide poisoning, personal injury and/or property damage could result.

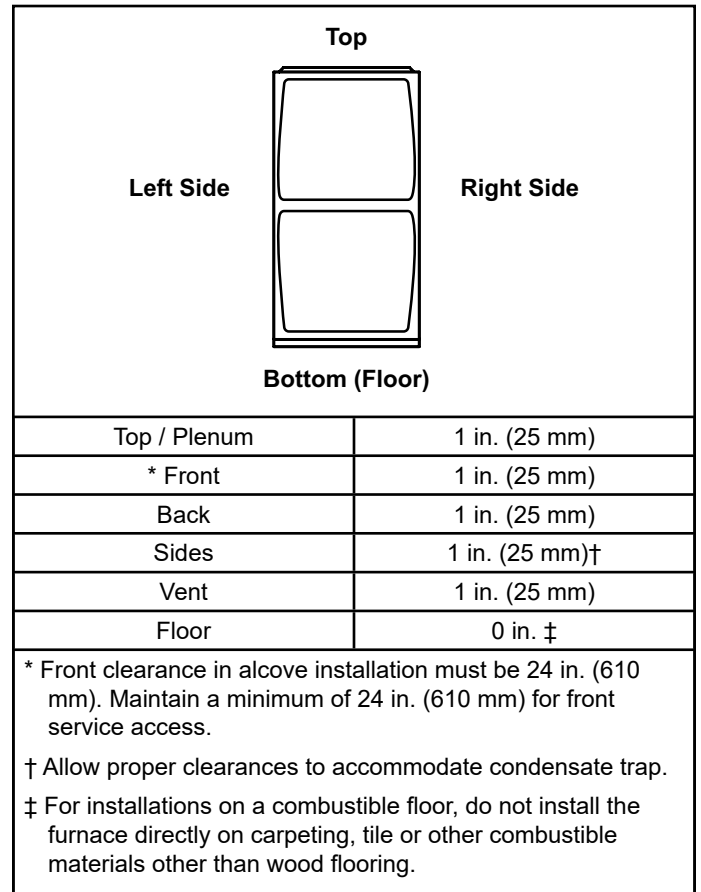

**Figure 11. Installation Clearances
Upflow Applications**

Return Air Guidelines

Return air can be brought in through the bottom or either side of the furnace installed in an upflow application. If the furnace is installed on a platform with bottom return, make an airtight seal between the bottom of the furnace and the platform to ensure that the furnace operates properly and safely. The furnace is equipped with a removable bottom panel to facilitate installation.

Markings are provided on both sides of the furnace cabinet for installations that require side return air. Cut the furnace cabinet at the maximum dimensions shown on Page 2.

Refer to Engineering Handbook for additional information.

95G1UHEX applications which include side return air and a condensate trap installed on the same side of the cabinet (trap can be installed remotely within 5 ft.) require either a return air base or field-fabricated transition to accommodate an optional IAQ accessory taller than 14.5". See Figure 14.

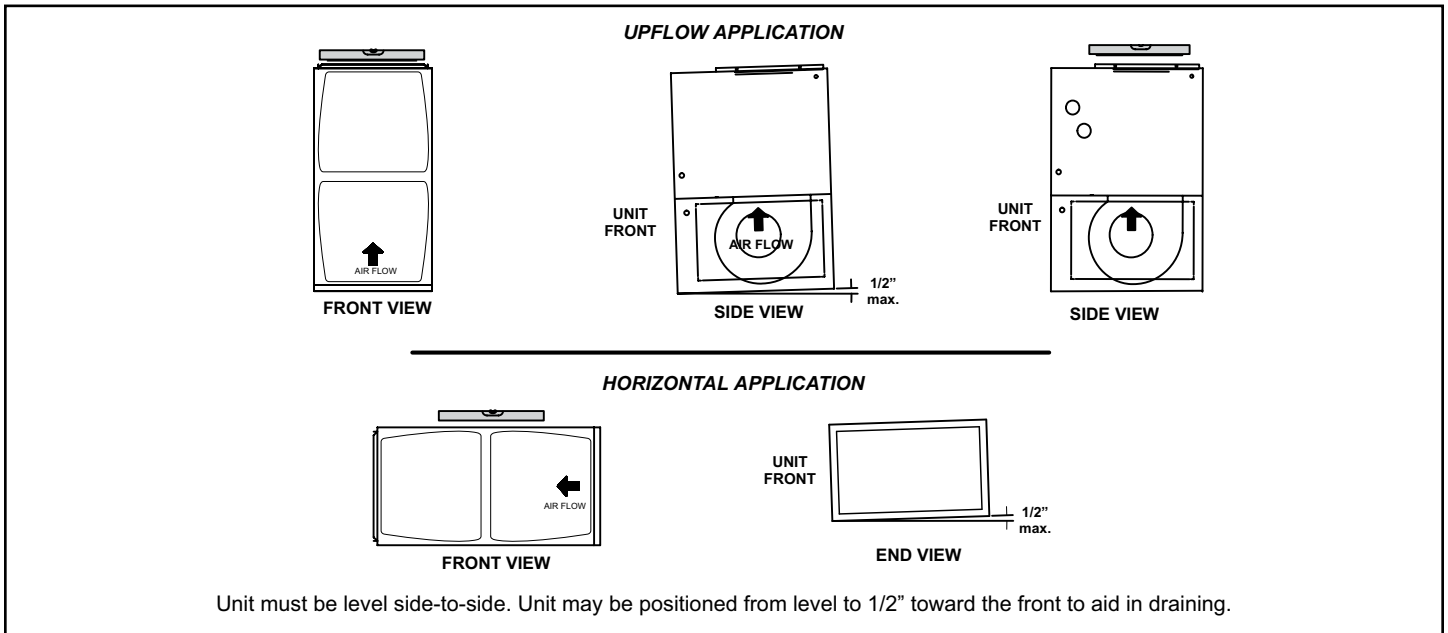

Figure 12. Setting Equipment

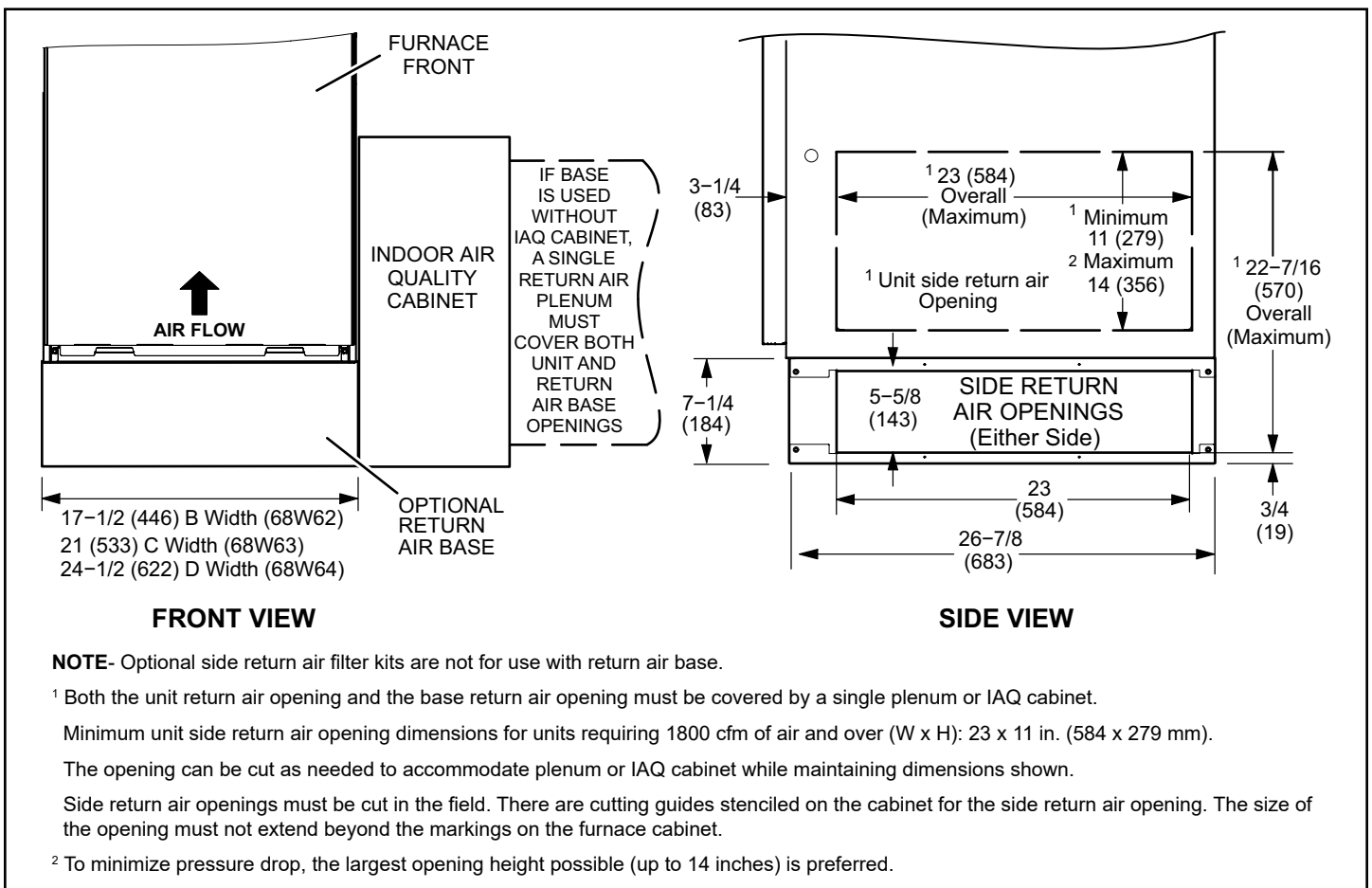

Figure 13. Optional Return Air Base (Upflow Applications Only)

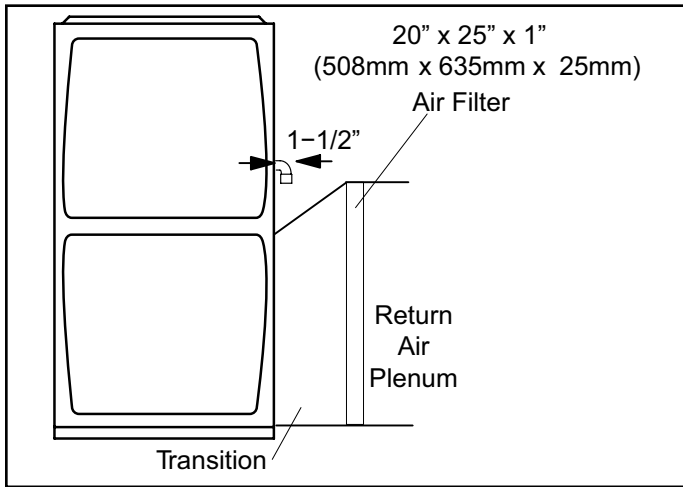

Figure 14. Side Return Air (with transition and filter)

Removing the Bottom Panel

Remove the two screws that secure the bottom cap to the furnace. Pivot the bottom cap down to release the bottom panel. Once the bottom panel has been removed, reinstall the bottom cap. See Figure 15.

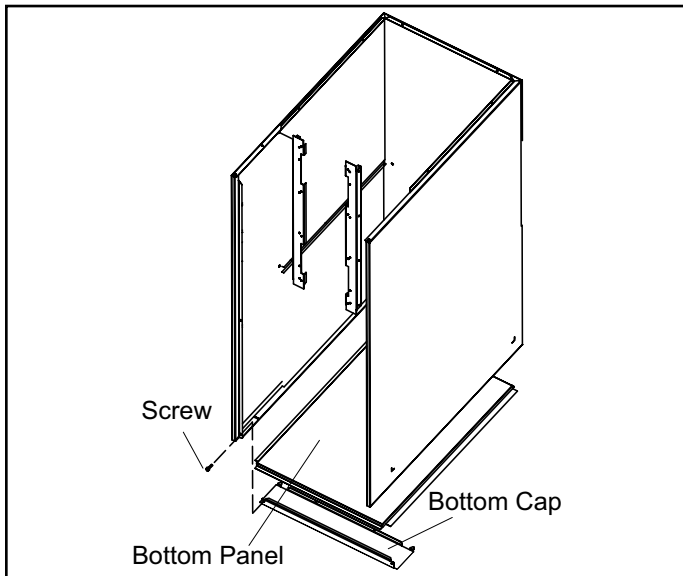

Figure 15. Remove the Bottom Panel

Horizontal Applications

The 95G1UHEX furnace can be installed in horizontal applications with either right- or left-hand air discharge.

Refer to Figure 17 for clearances in horizontal applications.

This furnace may be installed in either an attic or a crawlspace. Either suspend the furnace from roof rafters or floor joists, as shown in Figure 18, or install the furnace on a platform, as shown in Figure 19. A horizontal suspension kit (51W10) may be ordered from Allied Air or use equivalent.

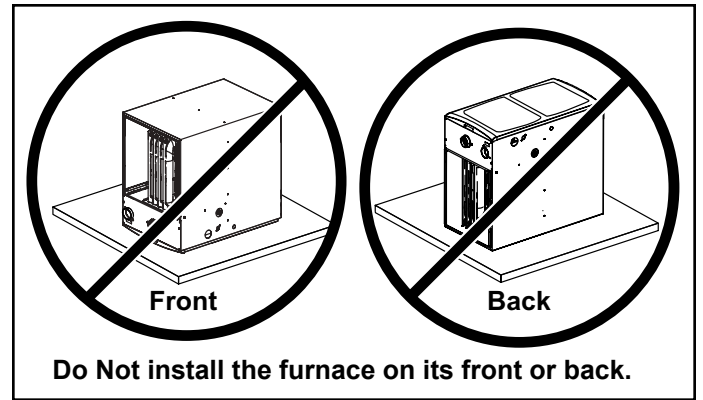

Figure 16.

Top	1 in. (25 mm)
* Front	1 in. (25 mm)
Back	1 in. (25 mm)
Ends	1 in. (25 mm)
Vent	1 in. (25 mm)
Floor	1 in. (25 mm) ‡

* Front clearance in alcove installation must be 24 in. (610 mm). Maintain a minimum of 24 in. (610 mm) for front service access.

** An 8" service clearance must be maintained below the unit to provide for servicing of the condensate trap.

‡ For installations on a combustible floor, do not install the furnace directly on carpeting, tile or other combustible materials other than wood flooring.

Figure 17. Installation Clearances Horizontal Applications

NOTE: Heavy-gauge sheet metal straps may be used to suspend the unit from roof rafters or ceiling joists. When straps are used to suspend the unit in this way, support must be provided for both the ends. The straps must not interfere with the plenum or exhaust piping installation. Cooling coils and supply and return air plenums must be supported separately.

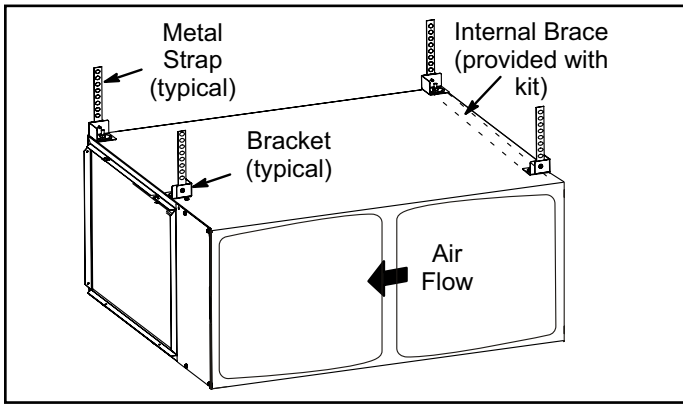

Figure 18. Horizontal Suspension Kit

NOTE: When the furnace is installed on a platform or with the horizontal suspension kit in a crawlspace, it must be elevated enough to avoid water damage, accommodate drain trap and to allow the evaporator coil to drain.

Platform Installation of Horizontal Unit

1. Select location for unit keeping in mind service and other necessary clearances. See Figure 17.
2. Construct a raised wooden frame and cover frame with a plywood sheet. If unit is installed above finished space, fabricate an auxiliary drain pan to be installed under unit. Set unit in drain pan as shown in Figure 19. Leave 8 inches for service clearance below unit for condensate trap.
3. Provide a service platform in front of unit. When installing the unit in a crawl space, a proper support platform may be created using cement blocks.
4. Route auxiliary drain line so that water draining from this outlet will be easily noticed by the homeowner.
5. If necessary, run the condensate line into a condensate pump to meet drain line slope requirements. The pump must be rated for use with condensing furnaces. Protect the condensate discharge line from the pump to the outside to avoid freezing.
6. Continue with exhaust, condensate and intake piping installation according to instructions.

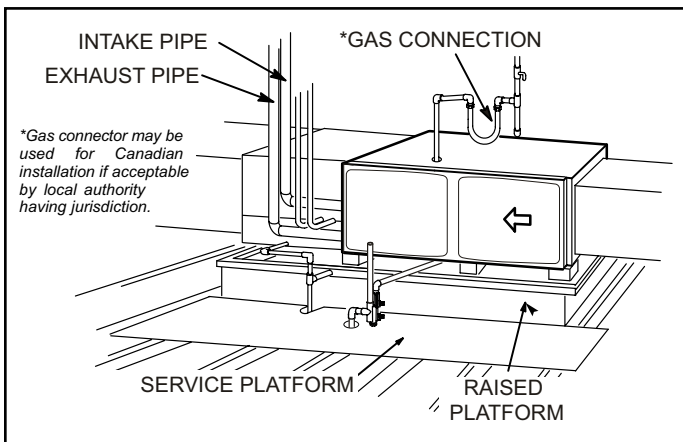

Figure 19. Platform Installation

Return air may be brought in only through the end of a furnace installed in the horizontal position. The furnace is equipped with a removable bottom panel to facilitate installation. See Figure 15.

Filters

This unit is not equipped with a filter or rack. A field-provided high velocity rated filter is required for the unit to operate properly. Table 1 lists recommended filter sizes.

A filter must be in place whenever the unit is operating.

Furnace Cabinet Width	Filter Size	
	Side Return	Bottom Return
17-1/2"	16 x 25 x 1 (1)	16 x 25 x 1 (1)
21"		20 x 25 x 1 (1)

Table 1.

IMPORTANT

If a highefficiency filter is being installed as part of this system to ensure better indoor air quality, the filter must be properly sized. Highefficiency filters have a higher static pressure drop than standard efficiency glass/foam filters. If the pressure drop is too great, system capacity and performance may be reduced. The pressure drop may also cause the limit to trip more frequently during the winter and the indoor coil to freeze in the summer, resulting in an increase in the number of service calls.

Before using any filter with this system, check the specifications provided by the filter manufacturer against the data given in the appropriate Allied Air Product Specifications bulletin. Additional information is provided in Service and Application Note ACC002 (August 2000).

Duct System

Use industry-approved standards to size and install the supply and return air duct system. Figure 20 shows the correct supply and return duct installation. Refer to ACCA Manual D. This will result in a quiet and low-static system that has uniform air distribution.

NOTE: This furnace is not certified for operation in heating mode (indoor blower operating at selected heating speed) with an external static pressure which exceeds 0.5 inches w.c. Operation at these conditions may result in improper limit operation.

Supply Air Plenum

If the furnace is installed without a cooling coil, a removable access panel should be installed in the supply air duct. The access panel should be large enough to permit inspection of the heat exchanger. The furnace access panel must always be in place when the furnace is operating and it must not allow leaks.

Return Air Plenum

NOTE: Return air must not be drawn from a room where this furnace, or any other gas-fueled appliance (i.e., water heater), or carbon monoxide-producing device (i.e., wood fireplace) is installed.

When return air is drawn from a room, a negative pressure is created in the room. If a gas appliance is operating in a room with negative pressure, the flue products can be pulled back down the vent pipe and into the room. This reverse flow of the flue gas may result in incomplete combustion and the formation of carbon monoxide gas. This raw gas or toxic fumes might then be distributed throughout the house by the furnace duct system.

Return air can be brought in through the bottom or either side of the furnace (return air brought into either side of furnace allowed in upflow applications only). If a furnace with bottom return air is installed on a platform, make an airtight seal between the bottom of the furnace and the platform to ensure that the unit operates properly and safely. Use fiberglass sealing strips, caulking, or equivalent sealing method between the plenum and the furnace cabinet to ensure a tight seal. If a filter is installed, size the return air duct to fit the filter frame.

Pipe & Fittings Specifications

All pipe, fittings, primer and solvent cement must conform with American National Standard Institute and the American Society for Testing and Materials (ANSI/ASTM) standards. The solvent shall be free flowing and contain no lumps, undissolved particles or any foreign matter that adversely affects the joint strength or chemical resistance of the cement. The cement shall show no gelation, stratification, or separation that cannot be removed by stirring. Refer to the Table 2 for approved piping and fitting materials.

⚠ CAUTION

Solvent cements for plastic pipe are flammable liquids and should be kept away from all sources of ignition. Do not use excessive amounts of solvent cement when making joints. Good ventilation should be maintained to reduce fire hazard and to minimize breathing of solvent vapors. Avoid contact of cement with skin and eyes.

⚠ IMPORTANT

95G1UHEX exhaust and intake connections are made of PVC. Use PVC primer and solvent cement when using PVC vent pipe. When using ABS vent pipe, use transitional solvent cement to make connections to the PVC fittings in the unit.

Use PVC primer and solvent cement or ABS solvent cement meeting ASTM specifications, refer to Table 2. As an alternate, use all purpose cement, to bond ABS, PVC, or CPVC pipe when using fittings and pipe made of the same materials. Use transition solvent cement when bonding ABS to either PVC or CPVC.

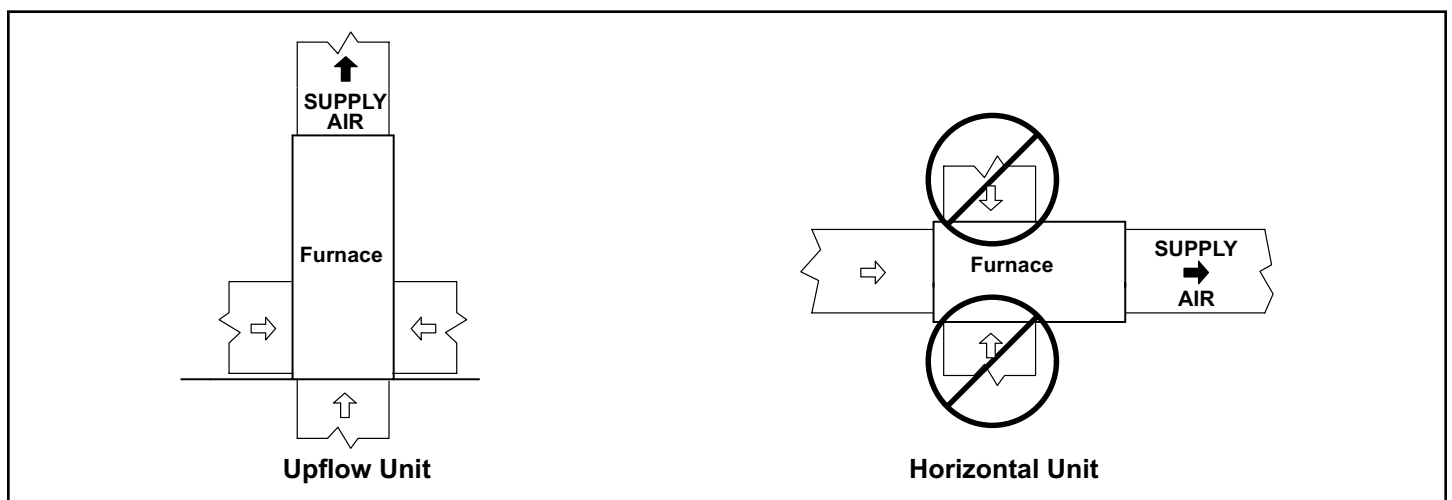

Figure 20. Duct System and Proper Installation

Low temperature solvent cement is recommended during cooler weather. Metal or plastic strapping may be used for vent pipe hangers. Uniformly apply a liberal coat of PVC primer for PVC or use a clean dry cloth for ABS to clean inside socket surface of fitting and male end of pipe to depth of fitting socket.

Schedule 40 PVC (Pipe)	D1785
Schedule 40 PVC (Cellular Core Pipe)	F891
Schedule 40 PVC (Fittings)	D2466
Schedule 40 CPVC (Pipe)	F441
Schedule 40 CPVC (Fittings)	F438
SDR-21 PVC or SDR-26 PVC (Pipe)	D2241
SDR-21 CPVC or SDR-26 CPVC (Pipe)	F442
Schedule 40 ABS Cellular Core DWV (Pipe)	F628
Schedule 40 ABS (Pipe)	D1527
Schedule 40 ABS (Fittings)	D2468
ABS-DWV (Drain Waste & Vent) (Pipe & Fittings)	D2661
PVC-DWV (Drain Waste & Vent) Pipe & Fittings)	D2665
PRIMER & SOLVENT CEMENT	ASTM SPECIFICATION
PVC & CPVC Primer	F656
PVC Solvent Cement	D2564
CPVC Solvent Cement	F493
ABS Solvent Cement	D2235
PVC/CPVC/ABS All Purpose Cement For Fittings & Pipe of the same material	D2564, D2235, F493
ABS to PVC or CPVC Transition Solvent Cement	D3138
CANADA PIPE & FITTING & SOLVENT CEMENT	MARKING
PVC & CPVC Pipe and Fittings	ULCS636
PVC & CPVC Solvent Cement	
ABS to PVC or CPVC Transition Cement	
POLYPROPYLENE VENTING SYSTEM	ULC-S636
PolyPro® by Duravent	
InnoFlue® by Centrotherm	
ECCO Polypropylene Vent™	

Table 2. Piping and Fittings Specifications

Canadian Applications Only - Pipe, fittings, primer and solvent cement used to vent (exhaust) this appliance must be certified to ULC S636 and supplied by a single manufacturer as part of an approved vent (exhaust) system. In addition, the first three feet of vent pipe from the furnace flue collar must be accessible for inspection.

NOTE: *The intake coupling on the furnace is ABS material. Use transitional solvent to make connections to PVC pipe.*

NOTE: *Exhaust coupling must be installed with provided appliance adapter. See Figure 23.*

Joint Cementing Procedure

All cementing of joints should be done according to the specifications outlined in ASTM D 2855.



DANGER **DANGER OF EXPLOSION!**

Fumes from PVC glue may ignite during system check. Allow fumes to dissipate for at least 5 minutes before placing unit into operation.

1. Measure and cut vent pipe to desired length.
2. Deburr and chamfer end of pipe, removing any ridges or rough edges. If end is not chamfered, edge of pipe may remove cement from fitting socket and result in a leaking joint.
NOTE: *Check the inside of vent pipe thoroughly for any obstruction that may alter furnace operation.*
3. Clean and dry surfaces to be joined.
4. Test fit joint and mark depth of fitting on outside of pipe.
5. Uniformly apply a liberal coat of PVC primer for PVC or use a clean dry cloth for ABS to clean inside socket surface of fitting and male end of pipe to depth of fitting socket.
NOTE: *Time is critical at this stage. Do not allow primer to dry before applying cement.*
6. Promptly apply solvent cement to end of pipe and inside socket surface of fitting. Cement should be applied lightly but uniformly to inside of socket. Take care to keep excess cement out of socket. Apply second coat to end of pipe.
7. Immediately after applying last coat of cement to pipe, and while both inside socket surface and end of pipe are wet with cement, forcefully insert end of pipe into socket until it bottoms out. Turn PVC pipe 1/4 turn during assembly (but not after pipe is fully inserted) to distribute cement evenly. DO NOT turn ABS or cellular core pipe.
NOTE: *Assembly should be completed within 20 seconds after last application of cement. Hammer blows should not be used when inserting pipe.*
8. After assembly, wipe excess cement from pipe at end of fitting socket. A properly made joint will show a bead around its entire perimeter. Any gaps may indicate an improper assembly due to insufficient solvent.
9. Handle joints carefully until completely set.

Input Size	Vent Pipe Dia. (in.)	STANDARD					CONCENTRIC		
		Flush-Mount Kit	Wall Kit		Wall Ring Kit	Field Fabricated	1-1/2 in.	2 in.	3 in.
			2 in.	3 in.	2 in.				
		51W11 (US) 51W12 (CA)	22G44 (US) 430G28 (CA)	44J40 (US) 481J20 (CA)	15F74		71M80 (US) 44W92 (CA)	69M29 (US) 44W92 (CA)	60L46 (US) 44W93 (CA)
040	2	³ YES	YES	¹ YES	¹ YES	⁵ YES	² YES		
	3	³ YES	YES	¹ YES	¹ YES	⁵ YES	² YES		
060	2	³ YES	YES	¹ YES	¹ YES	⁵ YES	² YES		
	3	³ YES	YES	¹ YES	¹ YES	⁵ YES	² YES		
080	2	³ YES		YES	YES	⁵ YES		YES	YES
	3	³ YES		YES	YES	⁵ YES		YES	YES
100	2	³ YES		YES	YES	⁵ YES		YES	YES
	3	³ YES		YES		⁵ YES		YES	YES

NOTE - Standard Terminations do not include any vent pipe or elbows external to the structure. Any vent pipe or elbows external to the structure must be included in total vent length calculations. See vent length tables.

* Kits must be properly installed according to kit instructions.

¹ Requires field-provided outdoor 1-1/2" exhaust accelerator.

² Concentric kits 71M80 and 44W92 include 1-1/2" outdoor accelerator, when used with 040 and 060 input models.

³ Flush mount kits 51W11 and 51W12 includes 1-1/2 in. outdoor exhaust accelerator, required when used with 040, 060 and 080 input models.

⁴ Termination kits 30G28, 44W92, 44W93 and 81J20 are certified to ULC S636 for use in Canada only.

⁵ See Table 8 for vent accelerator requirements.

Table 3. Outdoor Termination Kits

Venting Practices

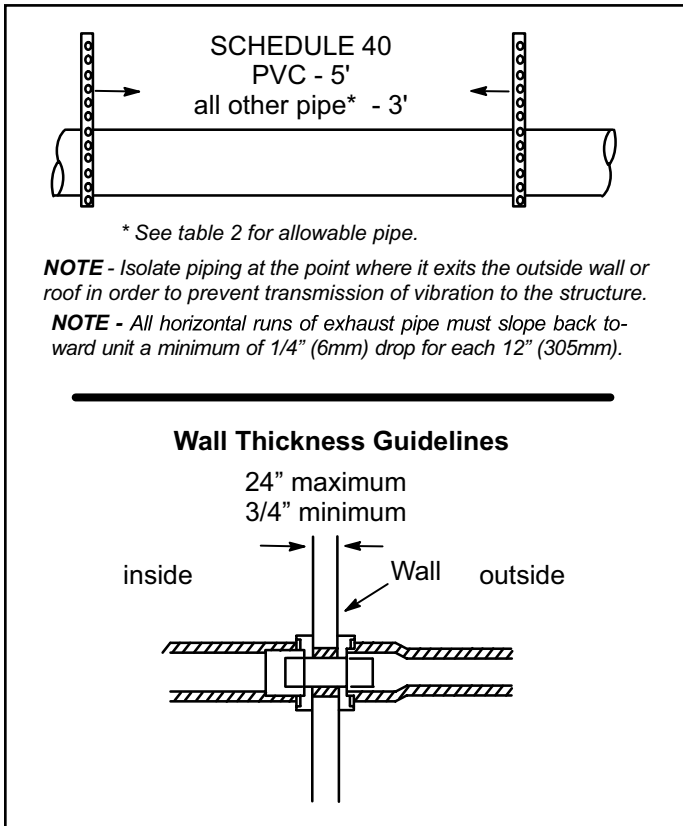

Figure 21. Piping Suspension Guidelines

1. In areas where piping penetrates joists or interior walls, hole must be large enough to allow clearance on all sides of pipe through center of hole using a hanger.
2. When furnace is installed in a residence where unit is shut down for an extended period of time, such as a vacation home, make provisions for draining condensate collection trap and lines.

Exhaust Piping

See Figure 23, Figure 26 and Figure 27

The appliance adapter must be attached to the exhaust coupling on the furnace top panel. Use the provided straps. See steps below.

1. Remove caution tag from vent adapter
2. Fully insert vent adapter with both bands loosely attached onto furnace exhaust coupling.
3. Insert PVC exhaust pipe through appliance adapter. Ensure vent pipe is fully seated into exhaust coupling.

4. Tighten both top and bottom bands to 40 in-lbs. See Figure 23.

Route piping to outside of structure. Continue with installation following instructions given in piping termination section.

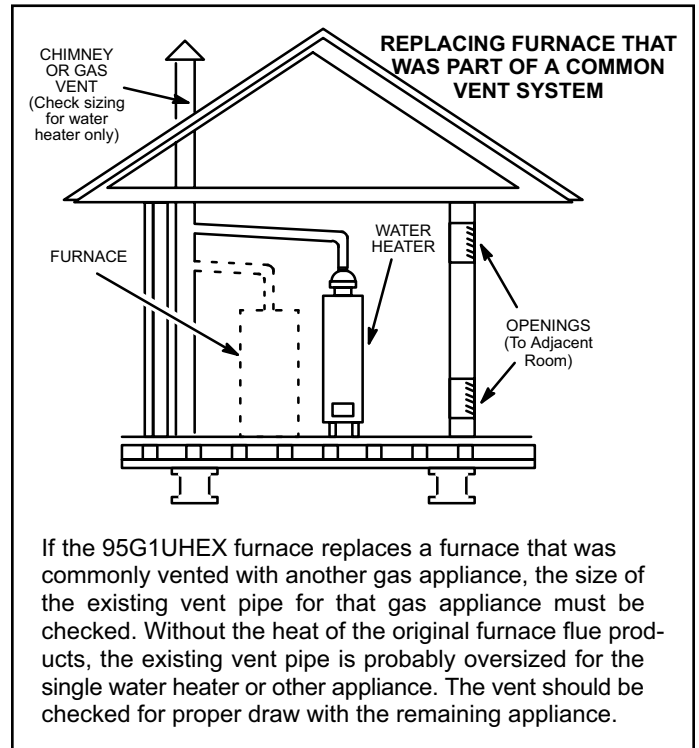

Figure 22.

CAUTION

Do not discharge exhaust into an existing stack or stack that also serves another gas appliance. If vertical discharge through an existing unused stack is required, insert PVC pipe inside the stack until the end is even with the top or outlet end of the metal stack.

CAUTION

The exhaust vent pipe operates under positive pressure and must be completely sealed to prevent leakage of combustion products into the living space.

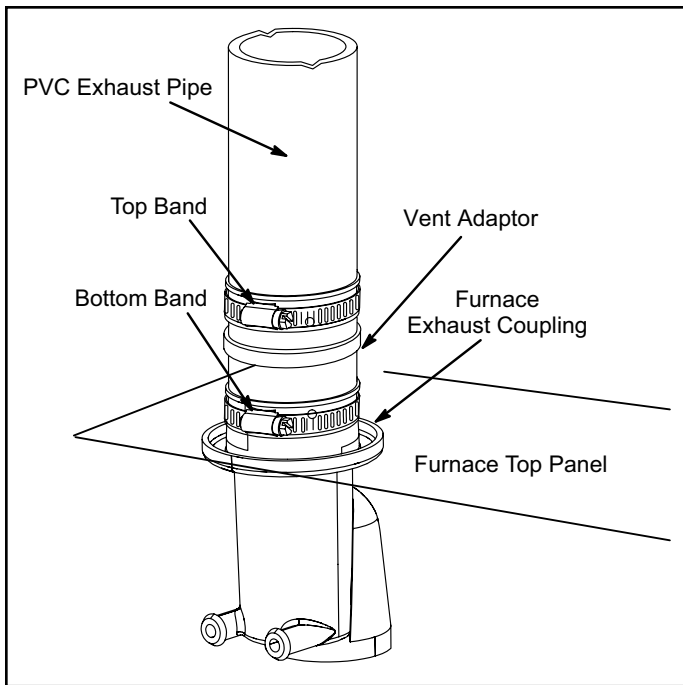

Figure 23. Appliance Adaptor to Exhaust Coupling

Vent Piping Guidelines

NOTE: Allied Air has approved the use of DuraVent® and Centrotherm manufactured vent pipe and terminations as an option to PVC. When using the PolyPro® by DuraVent or InnoFlue® by Centrotherm venting system the vent pipe requirements stated in the unit installation instruction – minimum & maximum vent lengths, termination clearances, etc. – apply and must be followed. Follow the instructions provided with PoyPro by DuraVent and InnoFlue by Centrotherm venting system for assembly or if requirements are more restrictive. The PolyPro by Duravent and InnoFlue by Centrotherm venting system must also follow the uninsulated and unconditioned space criteria listed in Table 7.

The 95G1UHEX can be installed as either a Non-Direct Vent or a Direct Vent gas central furnace.

NOTE: In Non-Direct Vent installations, combustion air is taken from indoors and flue gases are discharged outdoors. In Direct Vent installations, combustion air is taken from outdoors and flue gases are discharged outdoors.

Intake and exhaust pipe sizing -- Size pipe according to Table 4 and Table 5A. Count all elbows inside and outside the home. Table 4 lists the minimum vent pipe lengths permitted. Table 5A lists the maximum pipe lengths permitted. Regardless of the diameter of pipe used, the standard roof and wall terminations described in section Exhaust Piping Terminations should be used. Exhaust vent termination pipe is sized to optimize the velocity of the exhaust gas as it exits the termination. Refer to Table 8.

In some applications which permit the use of several different sizes of vent pipe, a combination vent pipe may be used. Contact the Allied Air Application Department for assistance in sizing vent pipe in these applications.

NOTE: The exhaust collar on all models is sized to accommodate 2" Schedule 40 vent pipe. In horizontal applications, any transition to exhaust pipe larger than 2" must be made in vertical runs of the pipe. Therefore a 2" elbow must be added before the pipe is transitioned to any size larger than 2". This elbow must be added to the elbow count used to determine acceptable vent lengths. Contact the Application Department for more information concerning sizing of vent systems which include multiple pipe sizes.

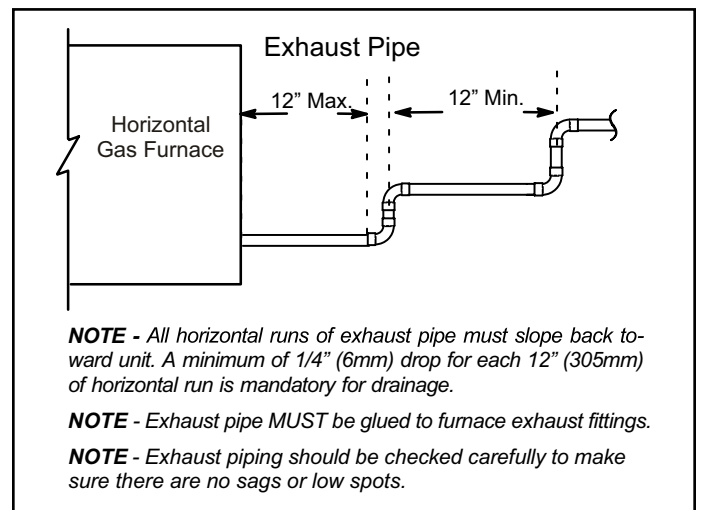

Figure 24. Horizontal Installation Offset Requirements

95G1UHEX Model	Min. Vent Length*
040, 060, 080, 100	15 ft. or 5 ft. plus 2 elbows or 10 ft. plus 1 elbow
*Any approved termination may be added to the minimum length listed.	

Table 4. Minimum Vent Pipe Lengths

⚠ IMPORTANT

Do not use screens or perforated metal in exhaust or intake terminations. Doing so will cause freeze-ups and may block the terminations.

Use the following steps to correctly size vent pipe diameter.

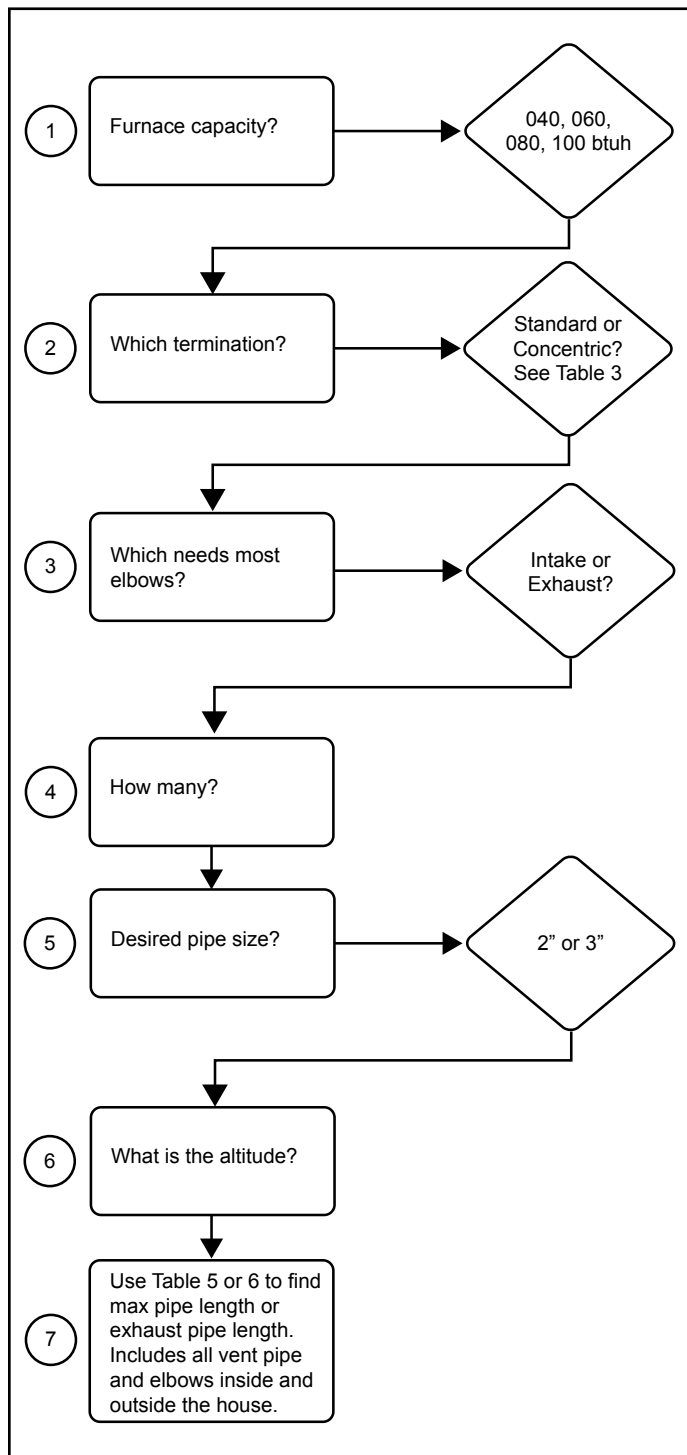

Figure 25.

Maximum Allowable Intake or Exhaust Vent Length in Feet

Standard Termination at Elevation 0 - 4500 ft									
Number of 90° Elbows Used	2" Pipe				3" Pipe				
	Model				Model				
	040	060	080	100	040	060	080	100	
1	81	66	44	24	138	137	118	118	
2	76	61	39	19	133	132	113	113	
3	71	56	34	14	128	127	108	108	
4	66	51	29	n/a	123	122	103	103	
5	61	46	24		118	117	98	98	
6	56	41	19		113	112	93	93	
7	51	36	14		108	107	88	88	
8	46	31	n/a		103	102	83	83	
9	41	26			98	97	78	78	
10	36	21			93	92	73	73	
Standard Termination at Elevation 4501 - 7500 ft									
Number of 90° Elbows Used	2" Pipe				3" Pipe				
	Model				Model				
	040	060	080	100	040	060	080	100	
1	81	41	34	9	138	105	100	65	
2	76	36	29	n/a	133	100	95	60	
3	71	31	24		128	95	90	55	
4	66	26	19		123	90	85	50	
5	61	21	14		118	85	80	45	
6	56	16	9		113	80	75	40	
7	51	11	n/a		108	75	70	35	
8	46	n/a			103	70	65	30	
9	41				98	65	60	25	
10	36				93	60	55	20	
<p>NOTE - Size intake and exhaust pipe length separately. Values in table are for Intake OR Exhaust, not combined total. Both Intake and Exhaust must be same pipe size.</p> <p>NOTE - Additional vent pipe and elbows used to terminate the vent pipe outside the structure must be included in the total vent length calculation.</p>									

Table 5A.

Maximum Allowable Intake or Exhaust Vent Length in Feet

Concentric Termination at Elevation 0 - 4500 ft								
Number of 90° Elbows Used	2" Pipe				3" Pipe			
	Model				Model			
	040	060	080	100	040	060	080	100
1	73	58	42	22	121	121	114	114
2	68	53	37	17	116	116	109	109
3	63	48	32	12	111	111	104	104
4	58	43	27	n/a	106	106	99	99
5	53	38	22		101	101	94	94
6	48	33	17		96	96	89	89
7	43	28	12		91	91	84	84
8	38	23	n/a		86	86	79	79
9	33	18			81	81	74	74
10	28	13			76	76	69	69
Concentric Termination at Elevation 4501 - 7500 ft								
Number of 90° Elbows Used	2" Pipe				3" Pipe			
	Model				Model			
	040	060	080	100	040	060	080	100
1	73	33	32	n/a	121	89	89	61
2	68	28	27		116	84	84	56
3	63	23	22		111	79	79	51
4	58	18	17		106	74	74	46
5	53	13	12		101	69	69	41
6	48	n/a	n/a		96	64	64	36
7	43				91	59	59	31
8	38				86	54	54	26
9	33				81	49	49	21
10	28	76	44		44	16		
<p>NOTE - Size intake and exhaust pipe length separately. Values in table are for Intake OR Exhaust, not combined total. Both Intake and Exhaust must be same pipe size.</p> <p>NOTE - Additional vent pipe and elbows used to terminate the vent pipe outside the structure must be included in the total vent length calculation.</p>								

Table 5B.

Maximum Allowable Exhaust Vent Lengths With Furnace Installed in a Closet or Basement Using Ventilated Attic or Crawl Space For Intake Air in Feet

Standard Termination at Elevation 0 - 4500 ft									
Number of 90° Elbows Used	2" Pipe				3" Pipe				
	Model				Model				
	040	060	080	100	040	060	080	100	
1	71	56	34	14	118	117	98	98	
2	66	51	29	9	113	112	93	93	
3	61	46	24	4	108	107	88	88	
4	56	41	19	n/a	103	102	83	83	
5	51	36	14		98	97	78	78	
6	46	31	9		93	92	73	73	
7	41	26	4		88	87	68	68	
8	36	21	n/a		83	82	63	63	
9	31	16			78	77	58	58	
10	26	11			73	72	53	53	
Standard Termination at Elevation 4501 - 7500 ft									
Number of 90° Elbows Used	2" Pipe				3" Pipe				
	Model				Model				
	040	060	080	100	040	060	080	100	
1	71	31	24	n/a	118	85	80	45	
2	66	26	19		113	80	75	40	
3	61	21	14		108	75	70	35	
4	56	16	9		103	70	65	30	
5	51	11	n/a		98	65	60	25	
6	46	n/a			93	60	55	20	
7	41				88	55	50	15	
8	36				83	50	45	10	
9	31				78	45	40	n/a	
10	26				73	40	35		

NOTE - Additional vent pipe and elbows used to terminate the vent pipe outside the structure must be included in the total vent length calculation.

Table 6.

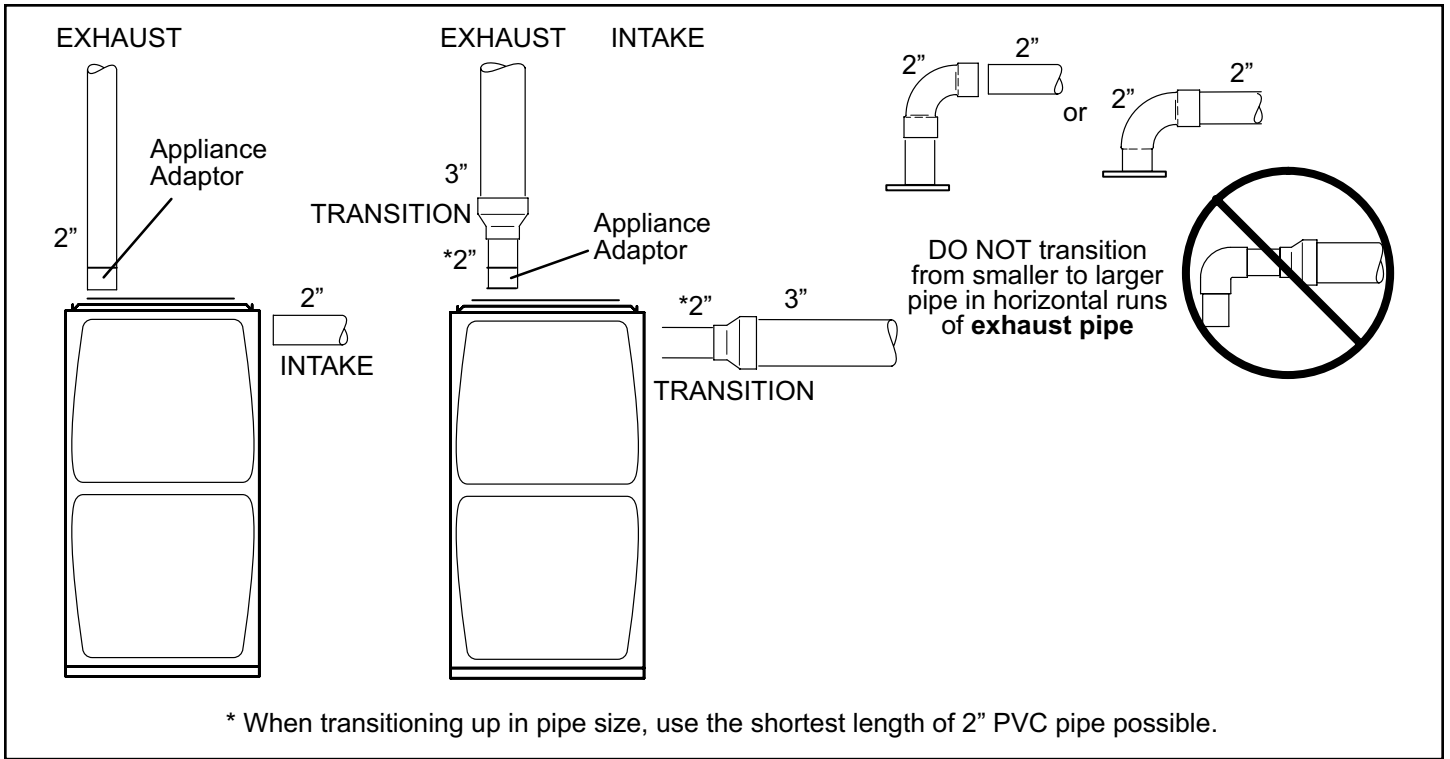

Figure 26. Typical Exhaust and Intake Pipe Connections in Upflow Direct Vent Applications

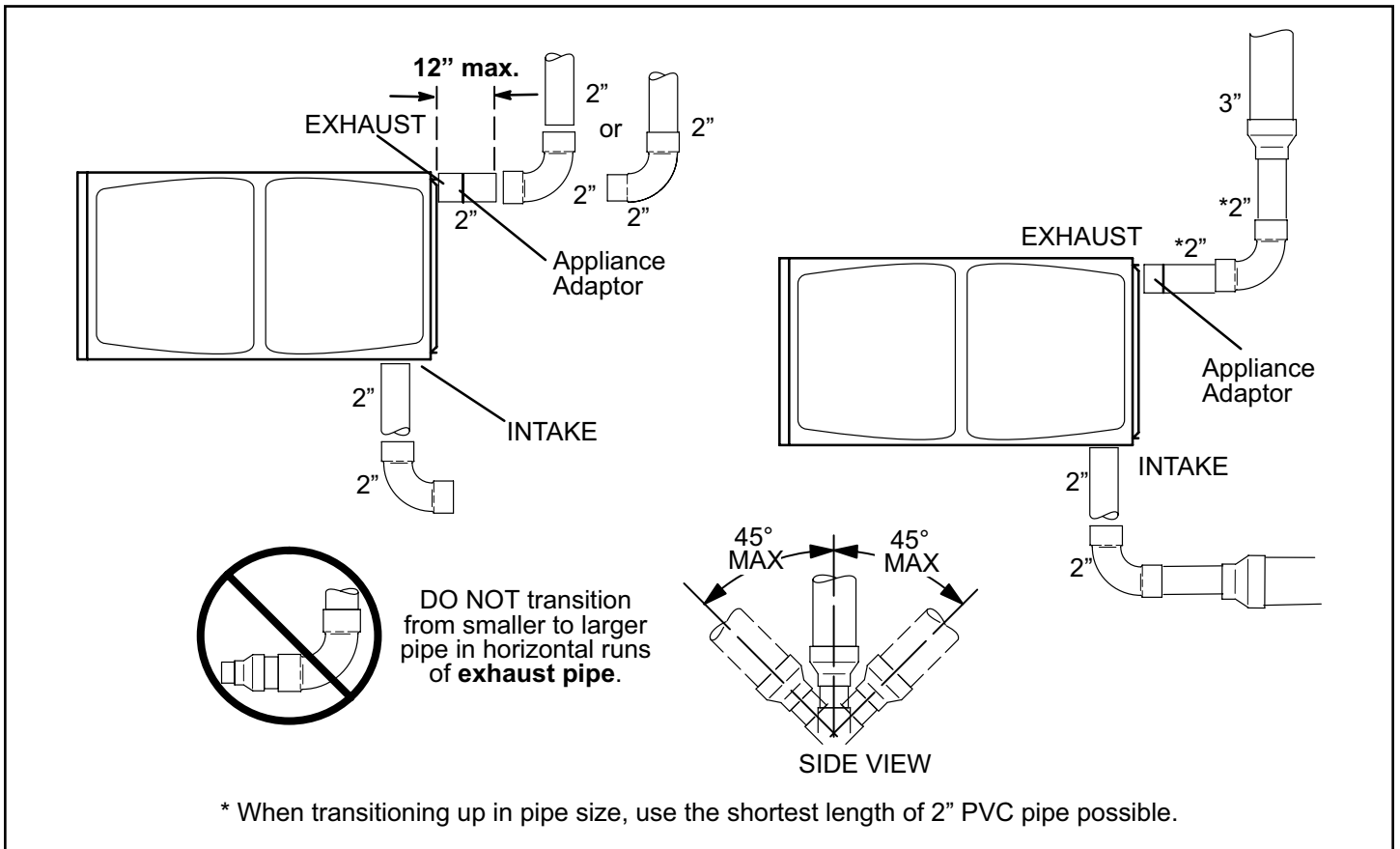

Figure 27. Typical Exhaust and Intake Pipe Connections in Horizontal Direct Vent Applications (Right Hand Discharge Shown)

Intake Piping

The 95G1UHEX furnace may be installed in either direct vent or non-direct vent applications. In non-direct vent applications, when intake air will be drawn into the furnace from the surrounding space, the indoor air quality must be considered and guidelines listed in Combustion, Dilution and Ventilation Air section must be followed.

Follow the next two steps when installing the unit in Direct Vent applications, where combustion air is taken from outdoors and flue gases are discharged outdoors. The provided air intake screen must not be used in direct vent applications (outdoors).

1. Use transition solvent cement or a sheet metal screw to secure the intake pipe to the inlet air connector.
2. Route piping to outside of structure. Continue with installation following instructions given in general guidelines for piping terminations and intake and exhaust piping terminations for direct vent sections. Refer to Table 5A for pipe sizes.

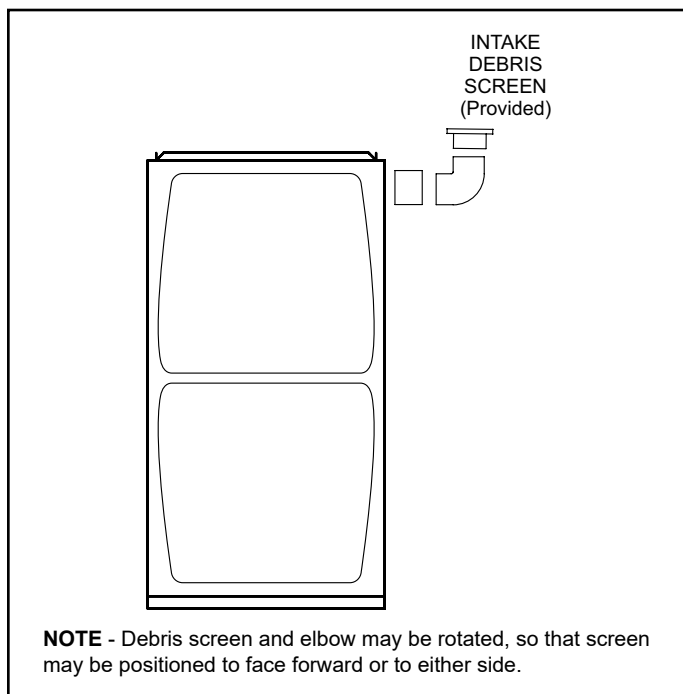

**Figure 28. Typical Air Intake Pipe Connections
Upflow Non-Direct Vent Applications**

Follow the next two steps when installing the unit in Non-Direct Vent applications where combustion air is taken from indoors and flue gases are discharged outdoors.

1. Use field-provided materials and the factory-provided air intake screen to route the intake piping as shown in Figure 28 or Figure 29. Maintain a minimum clearance of 3" (76mm) around the air intake opening. The air intake opening (with the protective screen) should always be directed forward or to either side in the upflow position, and either straight out or downward in the horizontal position.

The air intake piping must not terminate too close to the flooring or a platform. Ensure that the intake air inlet will not be obstructed by loose insulation or other items that may clog the debris screen.

2. If intake air is drawn from a ventilated attic (Figure 30) or ventilated crawlspace (Figure 31) the exhaust vent length must not exceed those listed in Table 6. If 3" diameter pipe is used, reduce to 2" diameter pipe at the termination point to accommodate the debris screen.
3. Use a sheet metal screw to secure the intake pipe to the connector, if desired.

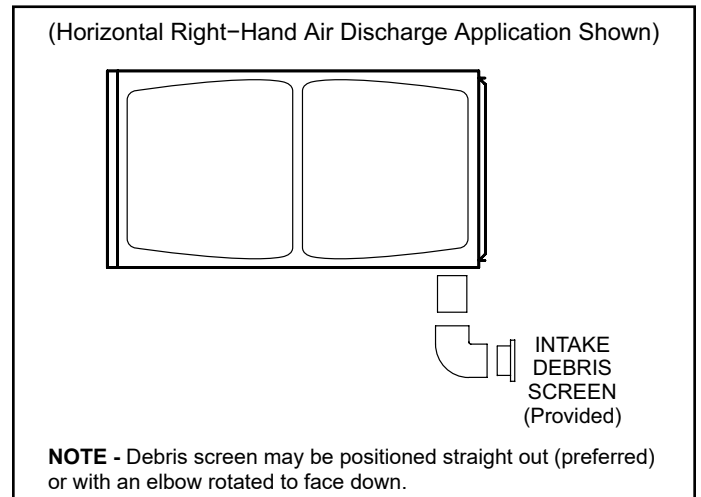

**Figure 29. Typical Air Intake Pipe Connections
Horizontal Non-Direct Vent Applications**

⚠ CAUTION

If this unit is being installed in an application with combustion air coming in from a space serviced by an exhaust fan, power exhaust fan, or other device which may create a negative pressure in the space, take care when sizing the inlet air opening. The inlet air opening must be sized to accommodate the maximum volume of exhausted air as well as the maximum volume of combustion air required for all gas appliances serviced by this space.

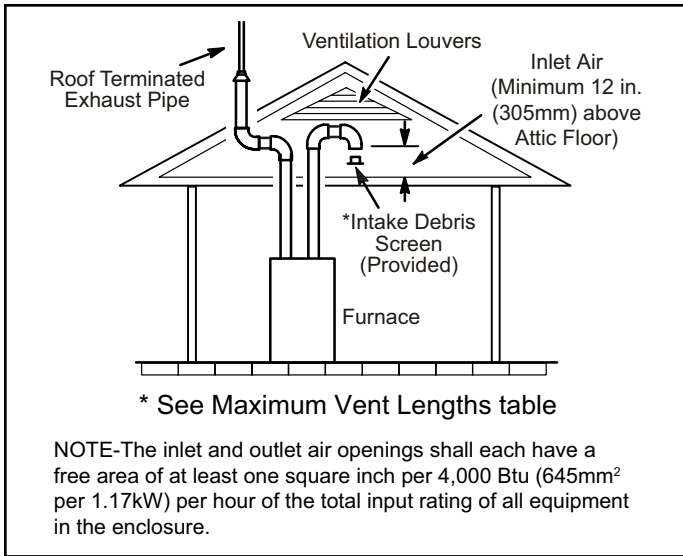

Figure 30. Equipment in Confined Space (Inlet Air from Ventilated Attic and Outlet Air to Outside)

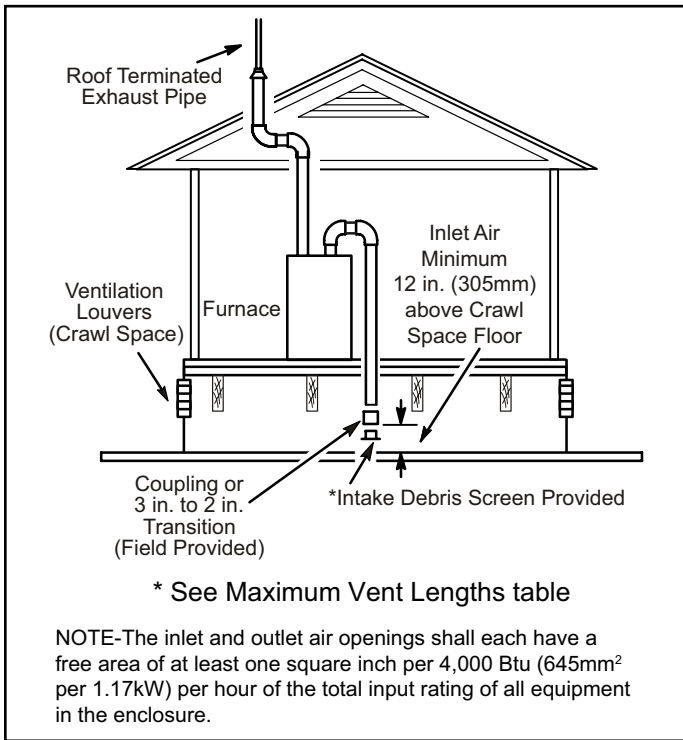

Figure 31. Equipment in Confined Space (Inlet Air from Ventilated Crawlspace and Outlet Air to Outside)

General Guidelines for Vent Terminations

In Non-Direct Vent applications, combustion air is taken from indoors and the flue gases are discharged to the outdoors. The 95G1UHEX is then classified as a non-direct vent, Category IV gas furnace.

In Direct Vent applications, combustion air is taken from outdoors and the flue gases are discharged to the outdoors. The 95G1UHEX is then classified as a direct vent, Category IV gas furnace.

In both Non-Direct Vent and Direct Vent applications, the vent termination is limited by local building codes. In the absence of local codes, refer to the current National Fuel Gas Code ANSI Z223-1/NFPA 54 in U.S.A., and current CSA-B149 Natural Gas and Propane Installation Codes in Canada for details.

Position termination according to location given in Figure 33 or Figure 43. In addition, position termination so it is free from any obstructions and 12" above the average snow accumulation.

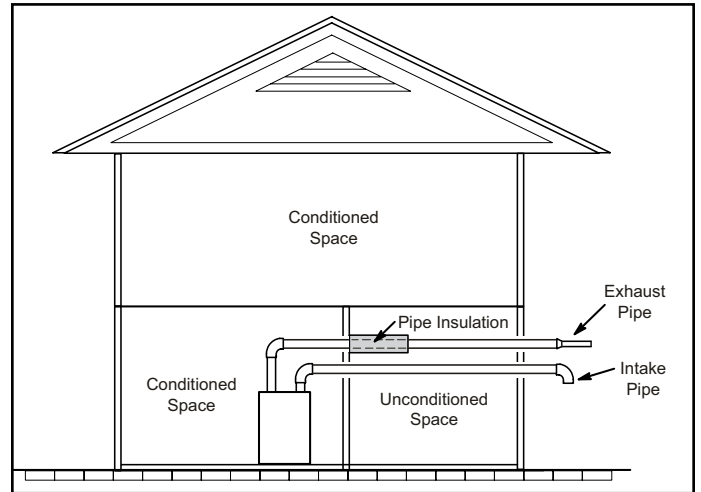

Figure 32. Insulating Exhaust Pipe in an Unconditioned Space

At vent termination, care must be taken to maintain protective coatings over building materials (prolonged exposure to exhaust condensate can destroy protective coatings). It is recommended that the exhaust outlet not be located within 6 feet (1.8m) of an outdoor AC unit because the condensate can damage the painted coating.

NOTE: See Table 7 for maximum allowed exhaust pipe length without insulation in unconditioned space during winter design temperatures below 32°F (0°C). If required exhaust pipe should be insulated with 1/2" (13mm) Armaflex or equivalent. In extreme cold climate areas, 3/4" (19mm) Armaflex or equivalent may be necessary. Insulation must be protected from deterioration. Armaflex with UV protection is permissible. Basements or other enclosed areas that are not exposed to the outdoor ambient temperature and are above 32 degrees F (0°C) are to be considered conditioned spaces.

▲ IMPORTANT

Do not use screens or perforated metal in exhaust terminations. Doing so will cause freeze-ups and may block the terminations.

▲ IMPORTANT

For Canadian Installations Only:

In accordance to CSA International B149 installation codes, the minimum allowed distance between the combustion air intake inlet and the exhaust outlet of other appliances shall not be less than 12 inches (305mm).

Maximum Allowable Exhaust Vent Pipe Length (in ft.) without Insulation in Unconditioned Space for Winter Design Temperatures									
Winter Design Temperatures ¹ °F (°C)	Vent Pipe Diameter	Unit Input Size							
		040		060		080		100	
		PVC	² PP	PVC	² PP	PVC	² PP	PVC	² PP
32 to 21 (0 to -6)	2 in.	18	16	31	28	50	48	30	30
	3 in.	9	9	18	18	35	35	47	47
20 to 1 (-7 to -17)	2 in.	9	8	18	16	32	29	30	30
	3 in.	N/A	N/A	8	8	19	19	26	26
0 to -20 (-18 to -29)	2 in.	5	N/A	12	10	22	19	30	27
	3 in.	N/A	N/A	N/A	N/A	10	10	16	16

¹ Refer to 99% Minimum Design Temperature table provided in the current edition of the ASHRAE Fundamentals Handbook.

² Poly-Propylene vent pipe (PP) by Duravent and Centrotherm

NOTE - Concentric terminations are the equivalent of 5' and should be considered when measuring pipe length.

NOTE- Maximum uninsulated vent lengths listed may include the termination (vent pipe exterior to the structure) and cannot exceed 5 linear feet or the maximum allowable intake or exhaust vent length listed in Table 5A or Table 6, whichever is less.

NOTE - If insulation is required in an unconditioned space, it must be located on the pipe closest to the furnace. See Figure 32.

Table 7.

VENT TERMINATION CLEARANCES FOR DIRECT VENT INSTALLATIONS IN THE USA AND CANADA

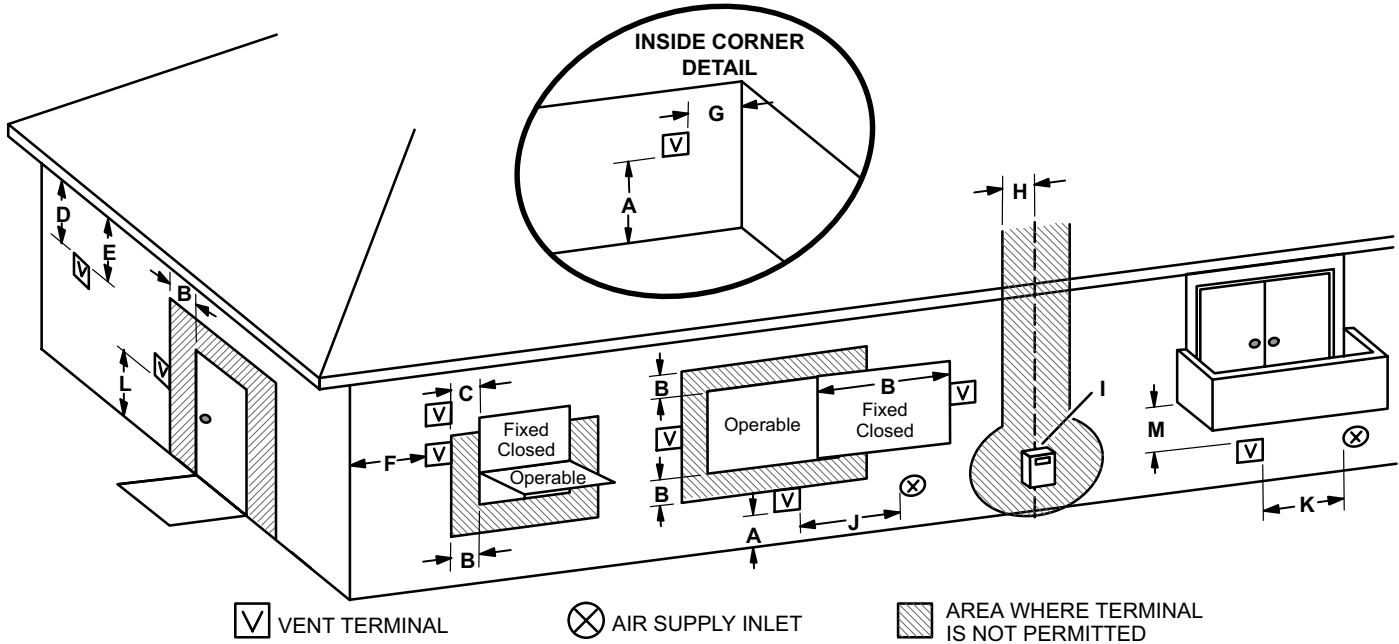

	US Installations ¹	Canadian Installations ²
A =	Clearance above grade, veranda, porch, deck or balcony	12 inches (305mm) or 12 in. (305mm) above average snow accumulation.
B =	Clearance to window or door that may be opened	6 inches (152mm) for appliances <10,000 Btuh (3kw), 9 inches (228mm) for appliances > 10,000 Btuh (3kw) and <50,000 Btuh (15kw), 12 inches (305mm) for appliances > 50,000 Btuh (15kw)
C =	Clearance to permanently closed window	* 12"
D =	Vertical clearance to ventilated soffit located above the terminal within a horizontal distance of 2 feet (610mm) from the center line of the terminal	* Equal to or greater than soffit depth
E =	Clearance to unventilated soffit	* Equal to or greater than soffit depth
F =	Clearance to outside corner	* No minimum to outside corner
G =	Clearance to inside corner	*
H =	Clearance to each side of center line extended above meter / regulator assembly	3 feet (.9m) within a height 15 feet (4.5m) above the meter / regulator assembly
I =	Clearance to service regulator vent outlet	* 3 feet (.9m)
J =	Clearance to non-mechanical air supply inlet to building or the combustion air inlet to any other appliance	6 inches (152mm) for appliances <10,000 Btuh (3kw), 9 inches (228mm) for appliances > 10,000 Btuh (3kw) and <50,000 Btuh (15kw), 12 inches (305mm) for appliances > 50,000 Btuh (15kw)
K =	Clearance to mechanical air supply inlet	3 feet (.9m) above if within 10 feet (3m) horizontally
L =	Clearance above paved sidewalk or paved driveway located on public property	* 7 feet (2.1m)
M =	Clearance under veranda, porch, deck or balcony	*12 inches (305mm)‡

¹ In accordance with the current ANSI Z223.1/NFPA 54 Natural Fuel Gas Code

² In accordance with the current CSA B149.1, Natural Gas and Propane Installation Code

† A vent shall not terminate directly above a sidewalk or paved driveway that is located between two single family dwellings and serves both dwellings.

‡ Permitted only if veranda, porch, deck or balcony is fully open on a minimum of two sides beneath the floor. Allied Air recommends avoiding this location if possible.

*For clearances not specified in ANSI Z223.1/NFPA 54 or CSA B149.1, clearance will be in accordance with local installation codes and the requirements of the gas supplier and these installation instructions."

Figure 33.

Details of Intake and Exhaust Piping Terminations for Direct Vent Installations

NOTE: In Direct Vent installations, combustion air is taken from outdoors and flue gases are discharged to outdoors.

NOTE: Flue gas may be slightly acidic and may adversely affect some building materials. If any vent termination is used and the flue gasses may impinge on the building material, a corrosion-resistant shield (minimum 24 inches square) should be used to protect the wall surface. If the optional tee is used, the protective shield is recommended. The shield should be constructed using wood, plastic, sheet metal or other suitable material. All seams, joints, cracks, etc. in the affected area should be sealed using an appropriate sealant. See Figure 42.

Intake and exhaust pipes may be routed either horizontally through an outside wall or vertically through the roof. In attic or closet installations, vertical termination through the roof is preferred. Figure 34 through Figure 41 show typical terminations.

1. Intake and exhaust terminations are not required to be in the same pressure zone. You may exit the intake on one side of the structure and the exhaust on another side (Figure 35). You may exit the exhaust out the roof and the intake out the side of the structure (Figure 36).
2. Intake and exhaust pipes should be placed as close together as possible at termination end (refer to illustrations). Minimum separation is 3" (76mm) on roof terminations and 6" (152mm) on side wall terminations.

NOTE: When venting in different pressure zones, the maximum separation requirement of intake and exhaust pipe DOES NOT apply.

3. On roof terminations, the intake piping should terminate straight down using two 90° elbows (see Figure 34).
4. Exhaust piping must terminate straight out or up as shown. A reducer may be required on the exhaust piping at the point where it exits the structure to improve the velocity of exhaust away from the intake piping. See Table 8.

NOTE: Care must be taken to avoid recirculation of exhaust back into intake pipe.

5. On field-supplied terminations for side wall exit, exhaust piping may extend a maximum of 12 inches (305mm) for 2" PVC and 20 inches (508mm) for 3" (76mm) PVC beyond the outside wall. Intake piping should be as short as possible. See Figure 42.
6. On field-supplied terminations, a minimum distance between the end of the exhaust pipe and the end of the intake pipe without a termination elbow is 8" and a minimum distance of 6" with a termination elbow. See Figure 42.

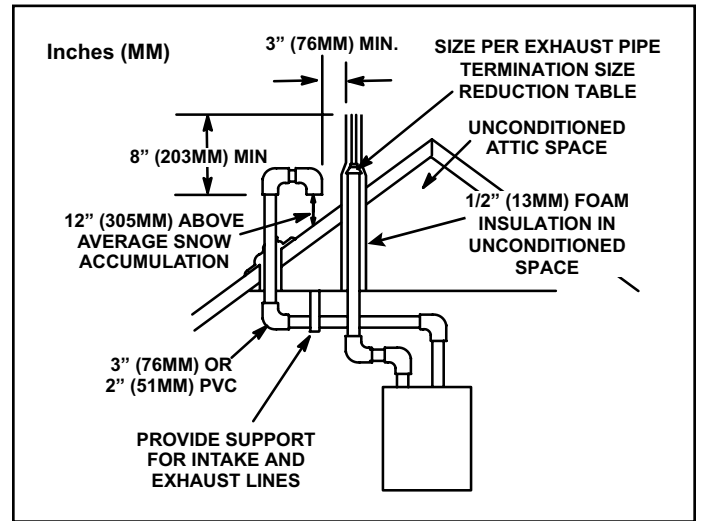

Figure 34. Direct Vent Roof Termination Kit

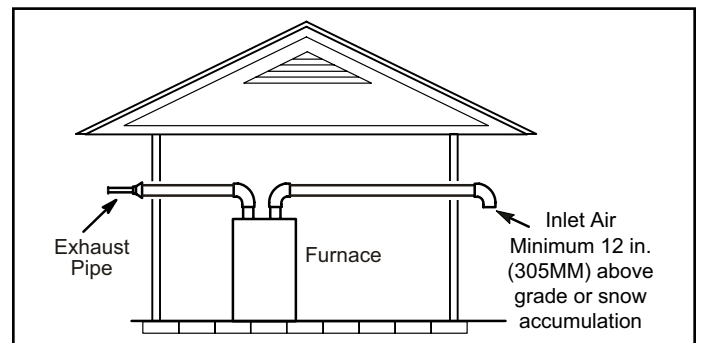

Figure 35. Exiting Exhaust and Intake Vent (no common pressure zone)

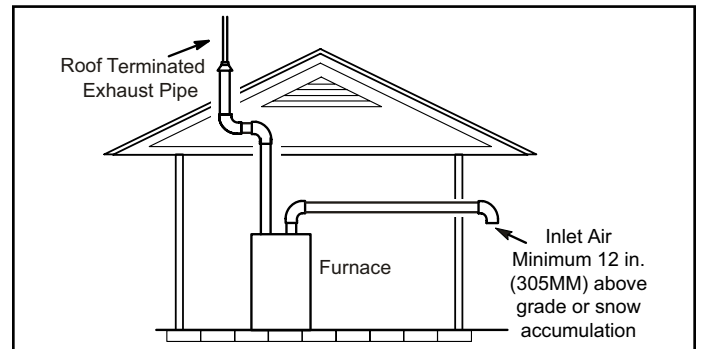

Figure 36. Exiting Exhaust and Intake Vent (no common pressure zone)

95G1UHEX Model	Termination Pipe Size
*040 and 060	1-1/2" (38 mm)
*080	2" (51 mm)
100	
*-040, -060 and -080 units with the flush mount termination must use the 1-1/2" accelerator supplied with the kit.	

Table 8. Exhaust Pipe Termination Size Reduction

7. If intake and exhaust piping must be run up a side wall to position above snow accumulation or other obstructions, piping must be supported. At least one bracket must be used within 6" from the top of the elbow and then every 24" (610mm) as shown in Figure 42, to prevent any movement in any direction. When exhaust and intake piping must be run up an outside wall, the exhaust piping must be terminated with pipe sized per Table 8. The intake piping may be equipped with a 90° elbow turndown. Using turndown will add 5 feet (1.5m) to the equivalent length of the pipe.
8. A multiple furnace installation may use a group of up to four terminations assembled together horizontally, as shown in Figure 41.

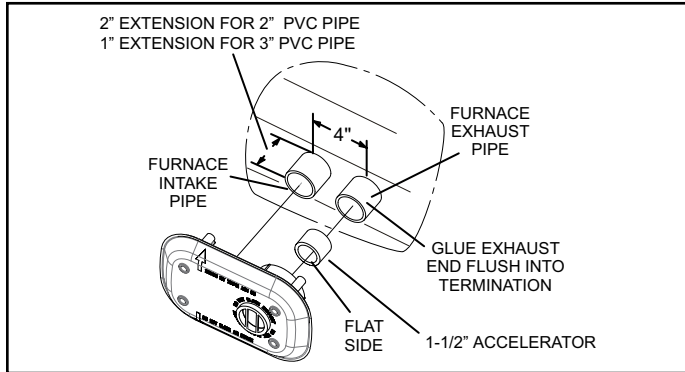

Figure 37. Flush-Mount Side Wall Termination 51W11

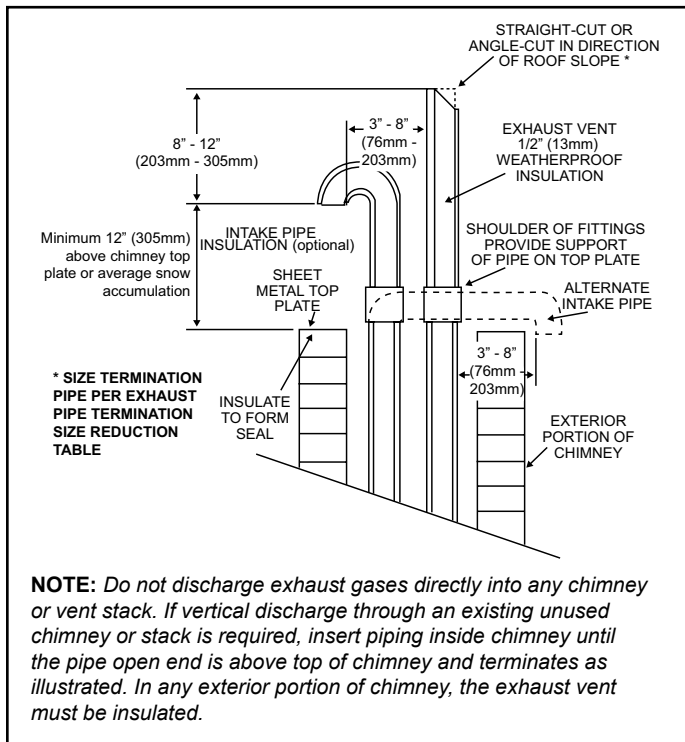
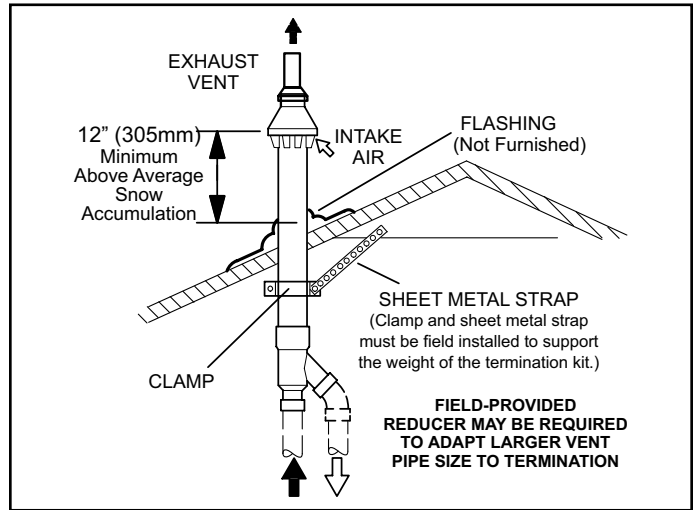
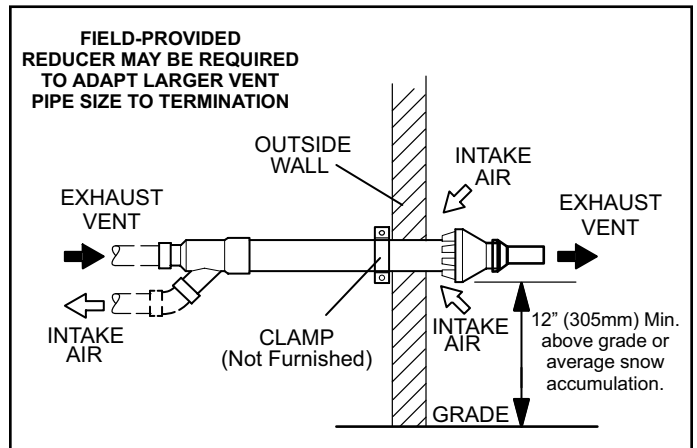

Figure 38. Direct Vent Application Using Existing Chimney



**Figure 39. Direct Vent Concentric Rooftop Termination
71M80, 69M29 or 60L46 (US)
41W92 or 41W93 (Canada)**



**Figure 40. Direct Vent Concentric Wall Termination
71M80, 69M29 or 60L46 (US)
41W92 or 41W93 (Canada)**

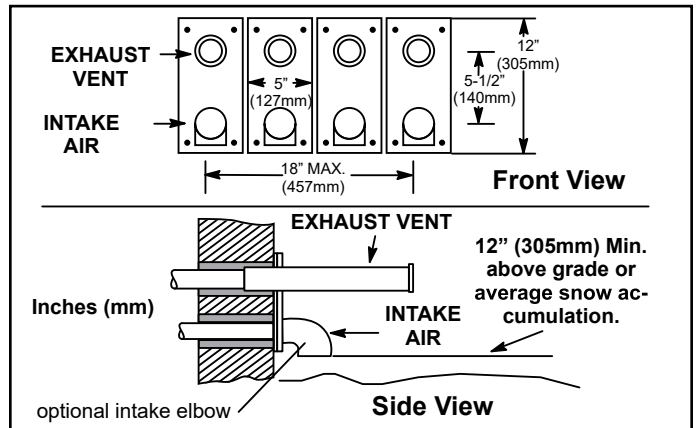
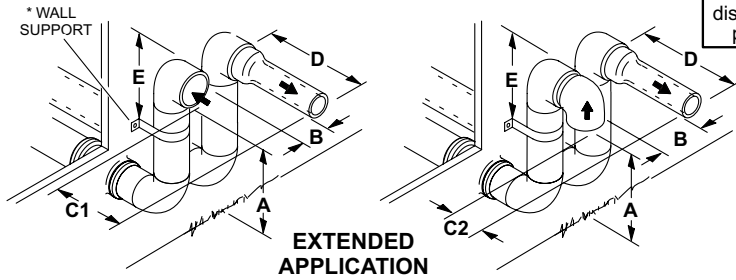
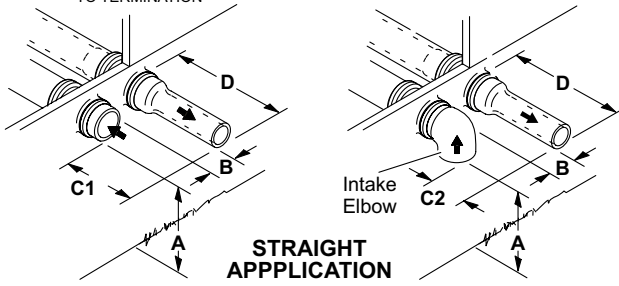

Figure 41. Optional Vent Termination for Multiple Unit Installation of Direct Vent Wall Termination

FIELD FABRICATED WALL TERMINATION

NOTE - FIELD-PROVIDED REDUCER MAY BE REQUIRED TO ADAPT LARGER VENT PIPE SIZE TO TERMINATION



	2" (51mm) Vent Pipe	3" (76mm) Vent Pipe
A - Minimum clearance above grade or average snow accumulation	12" (305 mm)	12" (305 mm)
B - Maximum horizontal separation between intake and exhaust	6" (152 mm)	6" (152 mm)
C1 -Minimum from end of exhaust to inlet of intake	8" (203 mm)	8" (203 mm)
C2 -Minimum from end of exhaust to inlet of intake	6" (152 mm)	6" (152 mm)
D - Maximum exhaust pipe length	12" (305 mm)	20" (508 mm)
E - Maximum wall support distance from top of each pipe (intake/exhaust)	6" (152 mm)	6" (152 mm)

* Use wall support every 24" (610 mm). Use two wall supports if extension is greater than 24" (610 mm) but less than 48" (1219 mm).
NOTE - One wall support must be within 6" (152 mm) from top of each pipe (intake and exhaust) to prevent movement in any direction.

ALTERNATE TERMINATIONS (TEE & FORTY-FIVE DEGREE ELBOWS ONLY)

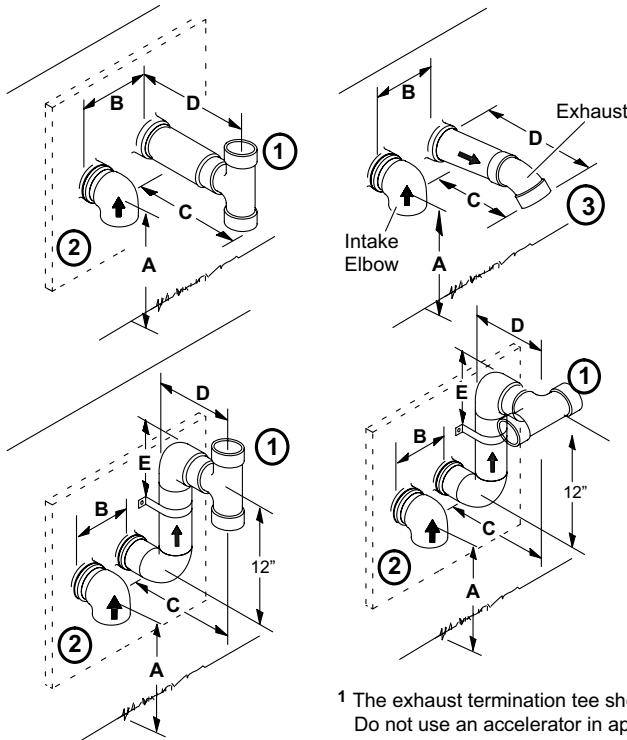

	2" (51MM) Vent Pipe	3" (76MM) Vent Pipe
A - Clearance above grade or average snow accumulation	12" (305 mm) Min.	12" (305 mm) Min.
B - Horizontal separation between intake and exhaust	6" (152 mm) Min. 24" (610 mm) Max.	6" (152 mm) Min. 24" (610 mm) Max.
C - Minimum from end of exhaust to inlet of intake	9" (227 mm) Min.	9" (227 mm) Min.
D - Exhaust pipe length	12" (305 mm) Min. 16" (405 mm) Max.	12" (305 mm) Min. 20" (508 mm) Max.
E - Wall support distance from top of each pipe (intake/exhaust)	6" (152 mm) Max.	6" (152 mm) Max.

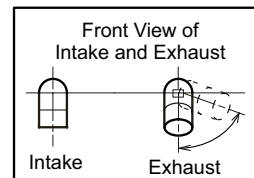

- 1 The exhaust termination tee should be connected to the 2" or 3" PVC flue pipe as shown in the illustration. Do not use an accelerator in applications that include an exhaust termination tee. The accelerator is not required.
- 2 As required. Flue gas may be acidic and may adversely affect some building materials. If a side wall vent termination is used and flue gases will impinge on the building materials, a corrosion-resistant shield (24 inches square) should be used to protect the wall surface. If optional tee is used, the protective shield is recommended. The shield should be constructed using wood, sheet metal or other suitable material. All seams, joints, cracks, etc. in affected area, should be sealed using an appropriate sealant.
- 3 Exhaust pipe 45° elbow can be rotated to the side away from the combustion air inlet to direct exhaust away from adjacent property. The exhaust must never be directed toward the combustion air inlet.

Figure 42.

VENT TERMINATION CLEARANCES FOR NON-DIRECT VENT INSTALLATIONS IN THE US AND CANADA

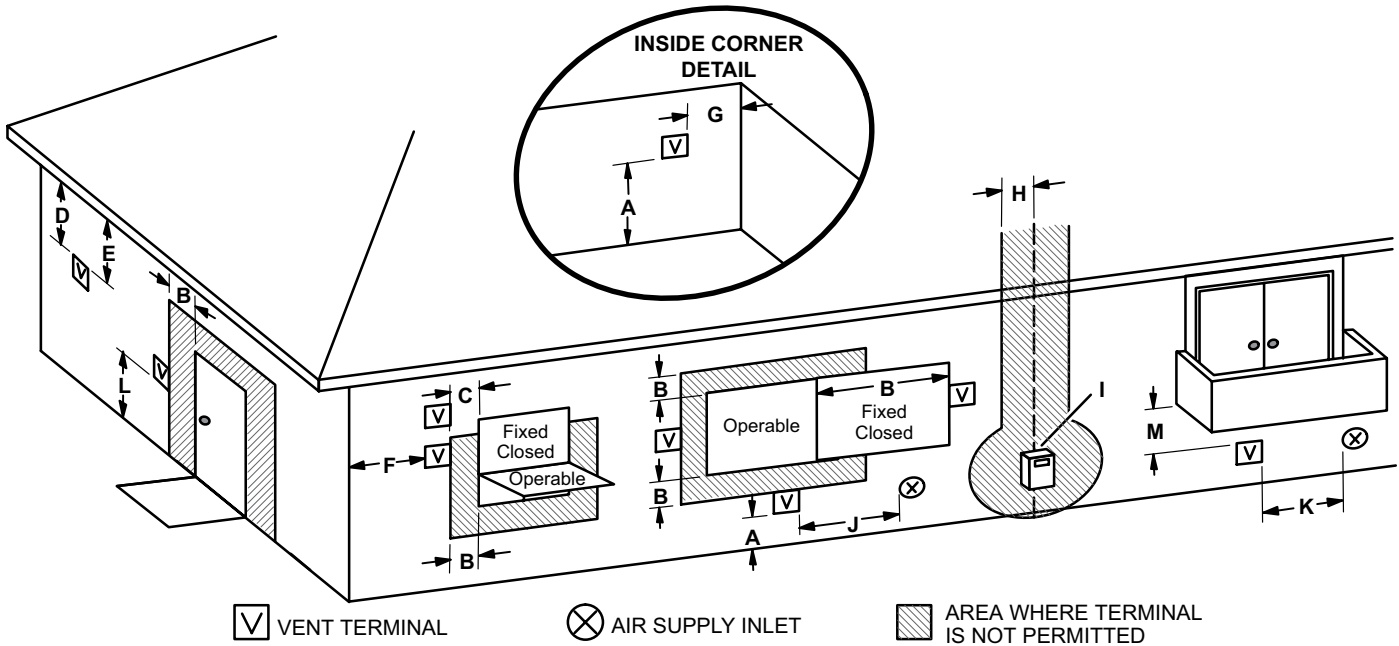

	US Installations ¹	Canadian Installations ²
A =	Clearance above grade, veranda, porch, deck or balcony	12 inches (305mm) or 12 in. (305mm) above average snow accumulation.
B =	Clearance to window or door that may be opened	4 feet (1.2 m) below or to side of opening; 1 foot (30cm) above opening
C =	Clearance to permanently closed window	* 12"
D =	Vertical clearance to ventilated soffit located above the terminal within a horizontal distance of 2 feet (610 mm) from the center line of the terminal	* Equal to or greater than soffit depth.
E =	Clearance to unventilated soffit	* Equal to or greater than soffit depth.
F =	Clearance to outside corner	* No minimum to outside corner
G =	Clearance to inside corner	*
H =	Clearance to each side of center line extended above meter / regulator assembly	* 3 feet (.9m) within a height 15 feet (4.5m) above the meter / regulator assembly
I =	Clearance to service regulator vent outlet	* 3 feet (.9m)
J =	Clearance to non-mechanical air supply inlet to building or the combustion air inlet to any other appliance	4 feet (1.2 m) below or to side of opening; 1 foot (30 cm) above opening
K =	Clearance to mechanical air supply inlet	3 feet (.9m) above if within 10 feet (3m) horizontally
L =	Clearance above paved sidewalk or paved driveway located on public property	7 feet (2.1m)†
M =	Clearance under veranda, porch, deck or balcony	*12 inches (305mm)‡

¹ In accordance with the current ANSI Z223.1/NFPA 54 Natural Fuel Gas Code

² In accordance with the current CSA B149.1, Natural Gas and Propane Installation Code

† A vent shall not terminate directly above a sidewalk or paved driveway that is located between two single family dwellings and serves both dwellings.

‡ Permitted only if veranda, porch, deck or balcony is fully open on a minimum of two sides beneath the floor. Allied Air recommends avoiding this location if possible.

*For clearances not specified in ANSI Z223.1/NFPA 54 or CSA B149.1, clearance will be in accordance with local installation codes and the requirements of the gas supplier and these installation instructions."

Figure 43.

Details of Exhaust Piping Terminations for Non-Direct Vent Applications

Exhaust pipes may be routed either horizontally through an outside wall or vertically through the roof. In attic or closet installations, vertical termination through the roof is preferred. Figure 44 and Figure 45 show typical terminations.

1. Exhaust piping must terminate straight out or up as shown. The termination pipe must be sized as listed in Table 8. The specified pipe size ensures proper velocity required to move the exhaust gases away from the building.
2. On field supplied terminations for side wall exit, exhaust piping may extend a maximum of 12 inches (305mm) for 2" PVC and 20 inches (508mm) for 3" (76mm) PVC beyond the outside wall.
3. If exhaust piping must be run up a side wall to position above snow accumulation or other obstructions, piping must be supported every 24 inches (610mm). When exhaust piping must be run up an outside wall, any reduction in exhaust pipe size must be done after the final elbow.
4. Distance between exhaust pipe terminations on multiple furnaces must meet local codes.

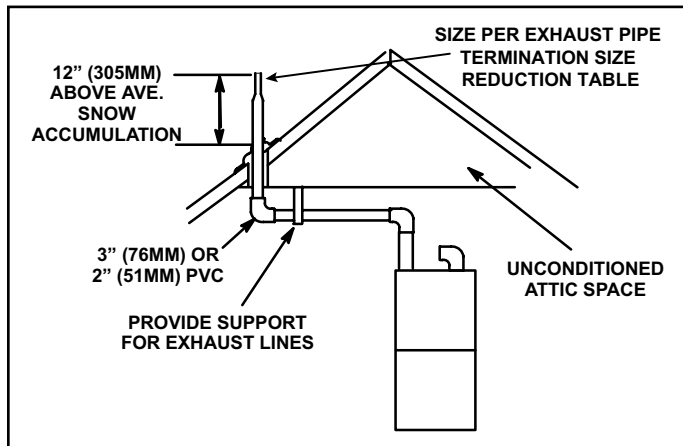

Figure 44. Non-Direct Vent Roof Termination Kit

Crawl Space and Extended Horizontal Venting

Allied Air provides kit 51W18 (USA) or kit 15Z70 (Canada) to install 2" or 3" PVC exhaust piping through the floor joists and into the crawl space. See Figure 46.

This kit can also be used as a supplemental drain for installations with condensate run back in the vent pipe (ie. long horizontal runs, unconditioned spaces, etc.).

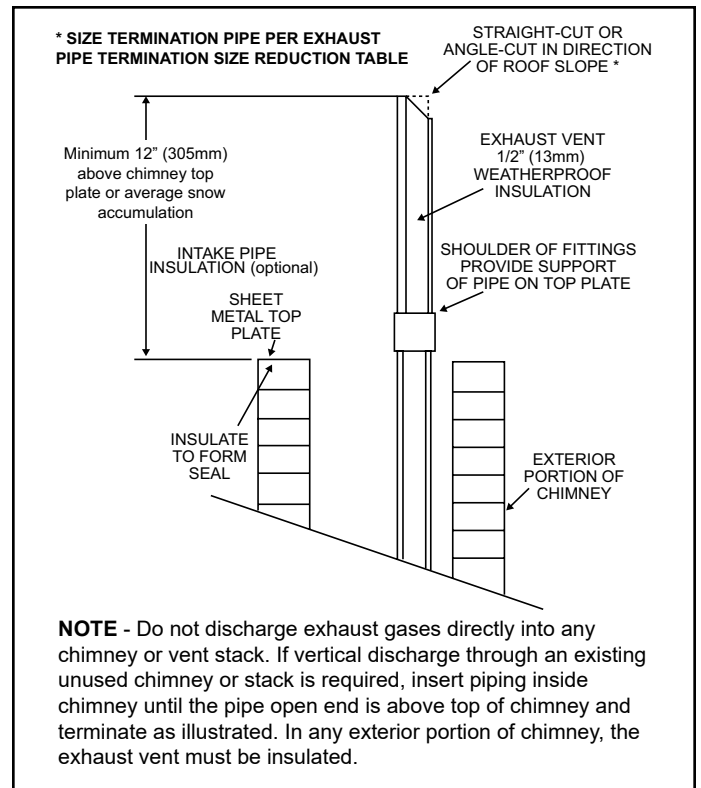

Figure 45. Non-Direct Vent Application Using Existing Chimney

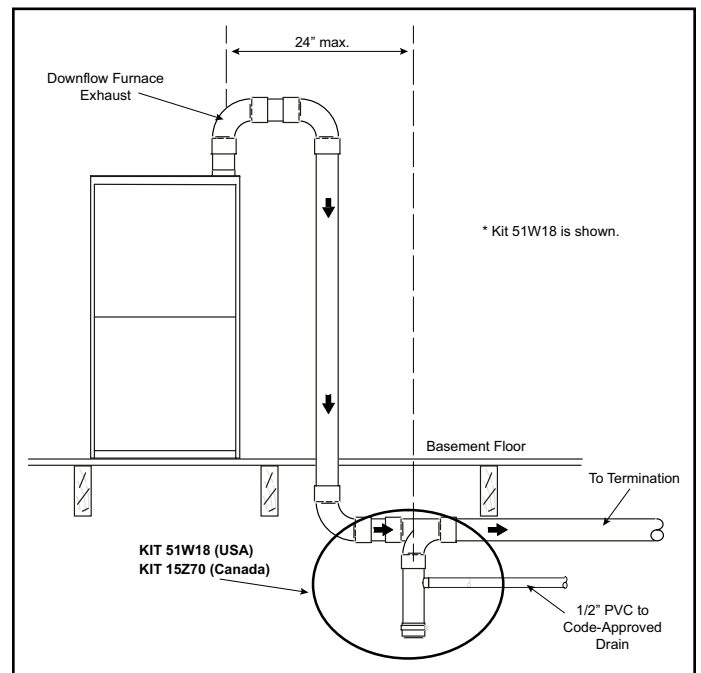

Figure 46. Venting in a Crawl Space

Condensate Piping

This unit is designed for either right- or left-side exit of condensate piping in upflow applications. In horizontal applications, the condensate trap must extend below the unit. An 8" service clearance is required for the condensate trap.

Refer to Figure 47 and Figure 49 for condensate trap locations. Figure 55 shows trap assembly using 1/2" PVC or 3/4" PVC.

NOTE: *If necessary the condensate trap may be installed up to 5' away from the furnace. Use PVC pipe to connect trap to furnace condensate outlet. Piping from furnace must slope down a minimum of 1/4" per ft. toward trap.*

1. Determine which side condensate piping will exit the unit, location of trap, field-provided fittings and length of PVC pipe required to reach available drain.
2. Use a large flat head screw driver or a 1/2" drive socket extension and remove plug (Figure 47) from the cold end header box at the appropriate location on the side of the unit. Install provided 3/4 NPT street elbow fitting into cold end header box. Use Teflon tape or appropriate pipe dope.

NOTE: *Cold end header box drain plugs are factory installed. Check the unused plug for tightness to prevent leakage.*

3. Install the cap over the clean out opening at the base of the trap. Secure with clamp. See Figure 55.

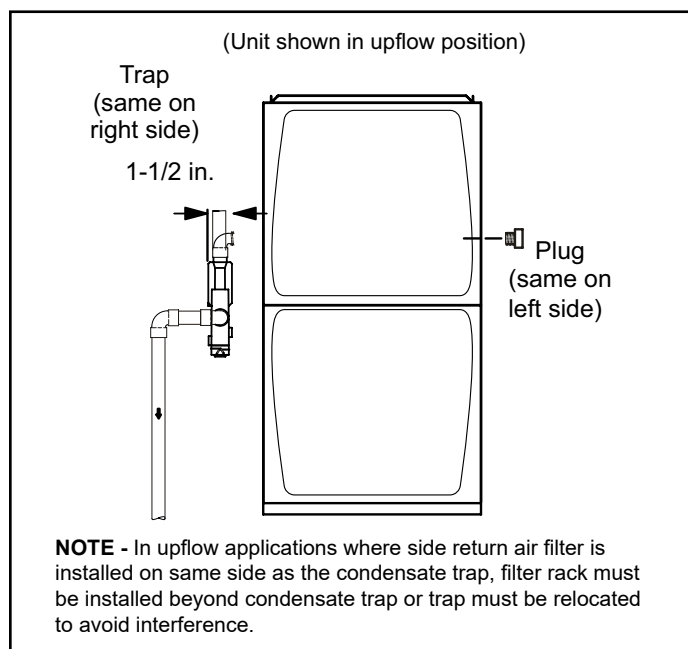

Figure 47. Condensate Trap and Plug Locations

4. Install drain trap using appropriate PVC fittings, glue all joints. Glue the provided drain trap as shown in Figure 55. Route the condensate line to an open drain.

Condensate line must maintain a 1/4" downward slope from the furnace to the drain.

5. Figure 51 and Figure 53 show the furnace and evaporator coil using a separate drain. If necessary the condensate line from the furnace and evaporator coil can drain together. See Figure 50, Figure 52 and Figure 54.

Upflow furnace (Figure 52) - In upflow furnace applications the field provided vent must be a minimum 1" to a maximum 2" length above the condensate drain outlet connection. Any length above 2" may result in a flooded heat exchanger if the combined primary drain line were to become restricted.

Horizontal furnace (Figure 54) - In horizontal furnace applications the field provided vent must be a minimum 4" to a maximum 5" length above the condensate drain outlet connection. Any length above 5" may result in a flooded heat exchanger if the combined primary drain line were to become restricted.

NOTE: *In horizontal applications it is recommended to install a secondary drain pan underneath the unit and trap assembly.*

NOTE: *Appropriately sized tubing and barbed fitting may be used for condensate drain. Attach to the drain on the trap using a hose clamp. See Figure 48.*

CAUTION

Do not use copper tubing or existing copper condensate lines for drain line.

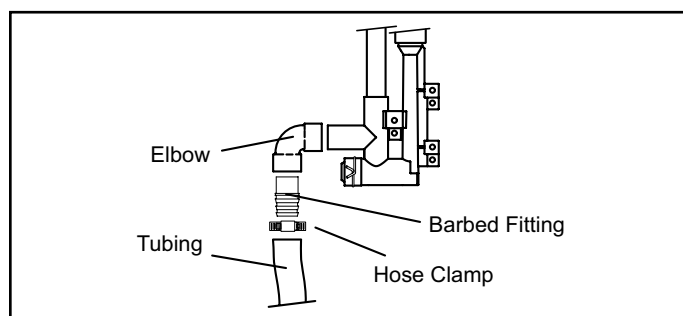

Figure 48. Field-Provided Drain Components

6. If unit will be started immediately upon completion of installation, prime trap per procedure outlined in Unit Start-Up section.

Condensate line must slope downward away from the trap to drain. If drain level is above condensate trap, condensate pump must be used. Condensate drain line should be routed within the conditioned space to avoid freezing of condensate and blockage of drain line. If this is not possible, a heat cable kit may be used on the condensate trap and line. Heating cable kit is available from Allied Air in various lengths; 6 ft. (1.8m) - kit no. 26K68 and 24 ft. (7.3m) - kit no. 26K69.

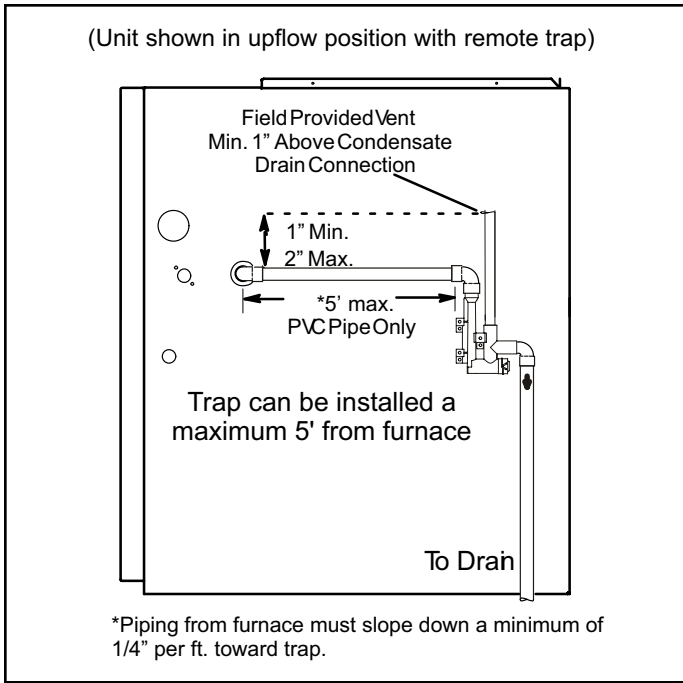

Figure 49. Condensate Trap Locations

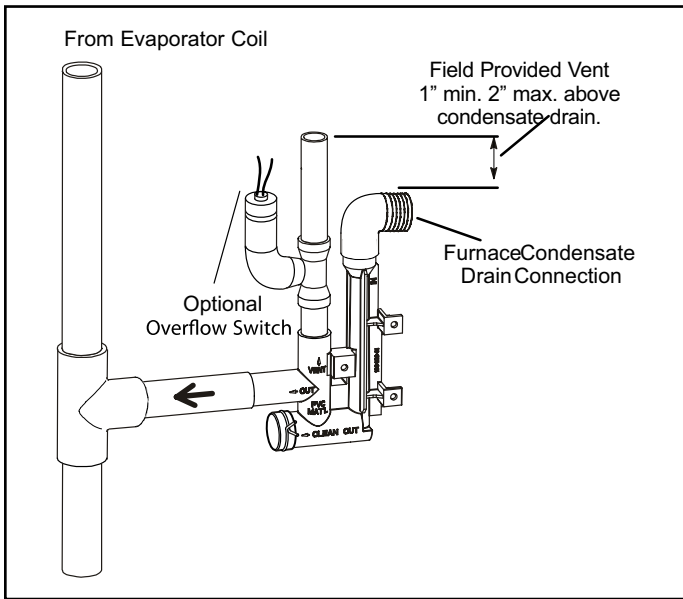

Figure 50. Condensate Trap With Optional Overflow Switch

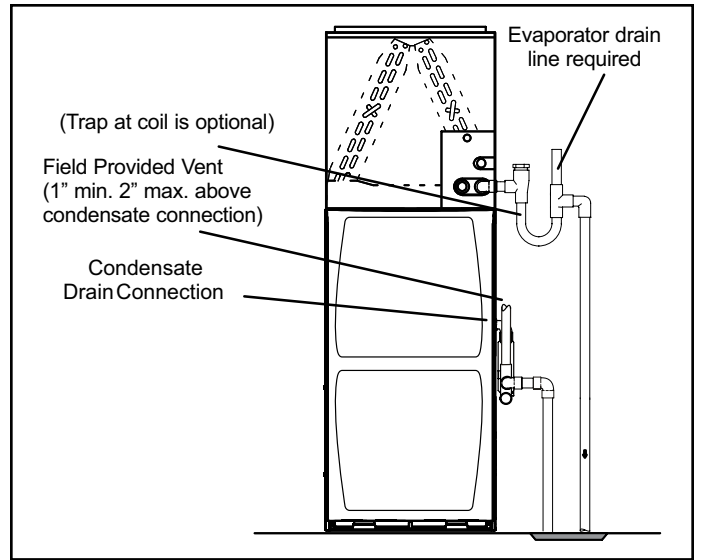

Figure 51. Furnace with Evaporator Coil Using a Separate Drain

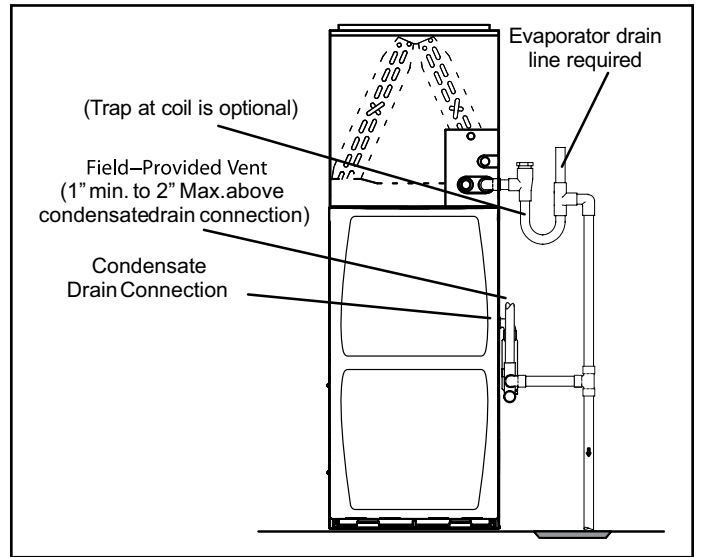

Figure 52. Furnace with Evaporator Coil Using a Common Drain

⚠ IMPORTANT

When combining the furnace and evaporator coil drains together, the A/C condensate drain outlet must be vented to relieve pressure in order for the furnace pressure switch to operate properly.

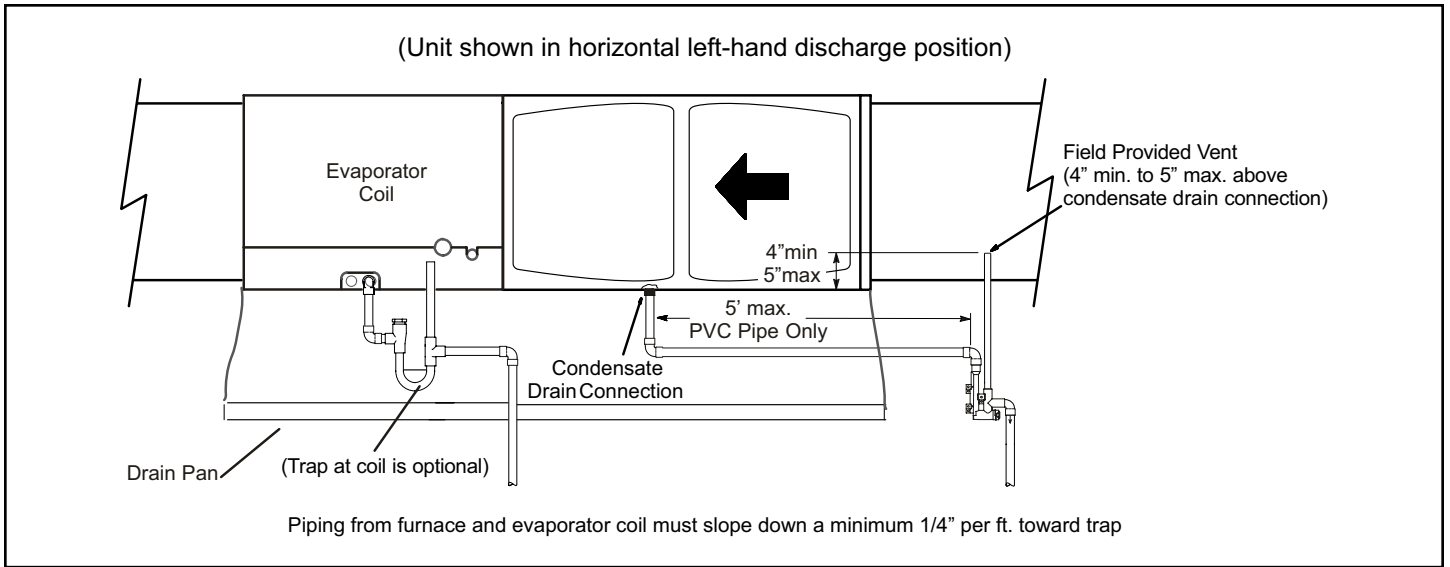

Figure 53. Furnace with Evaporator Coil Using a Separate Drain

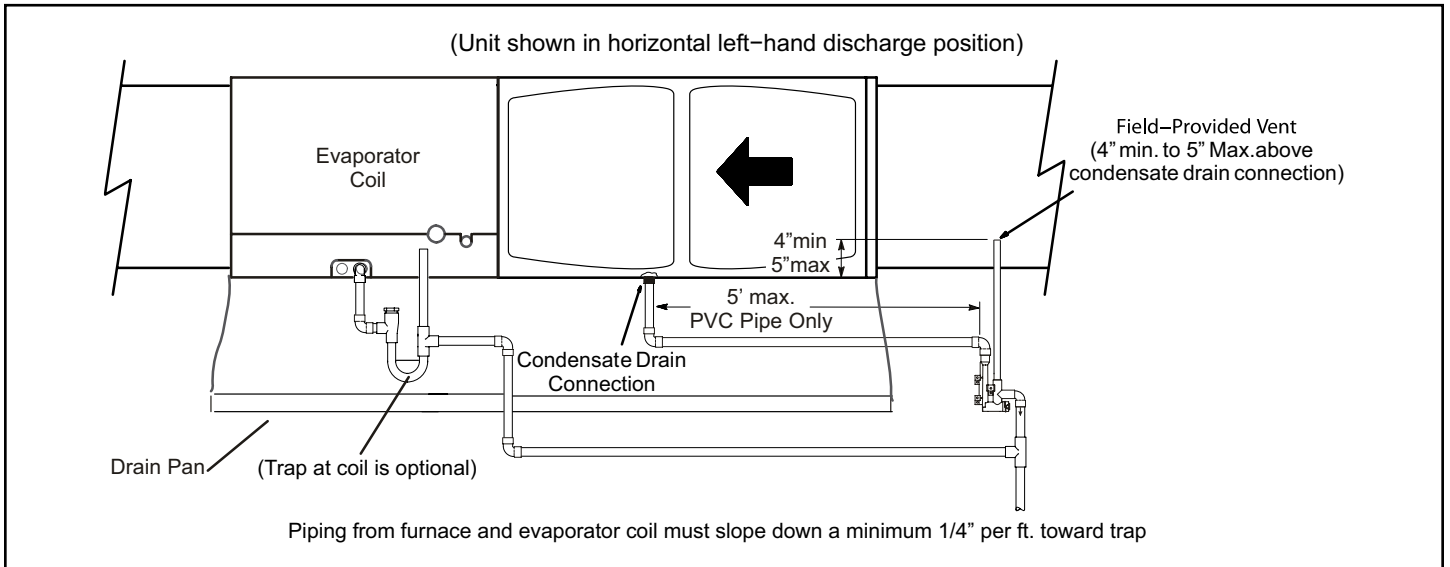
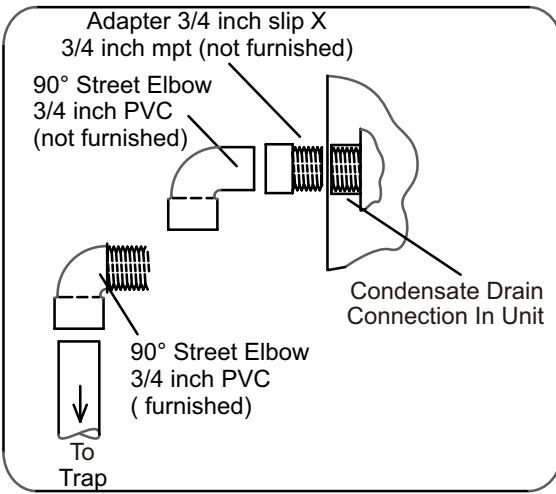
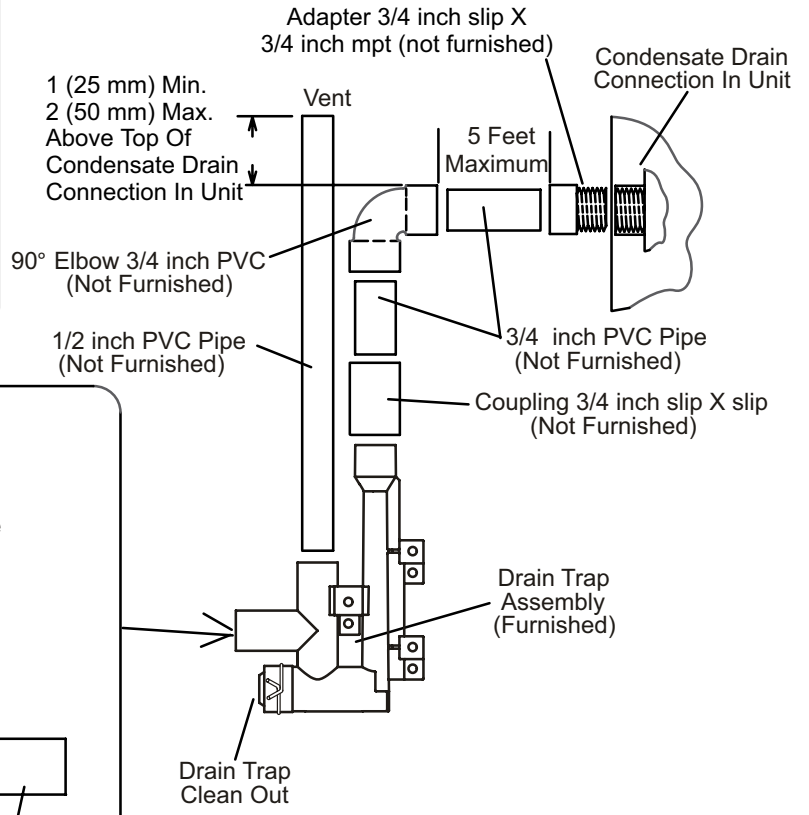
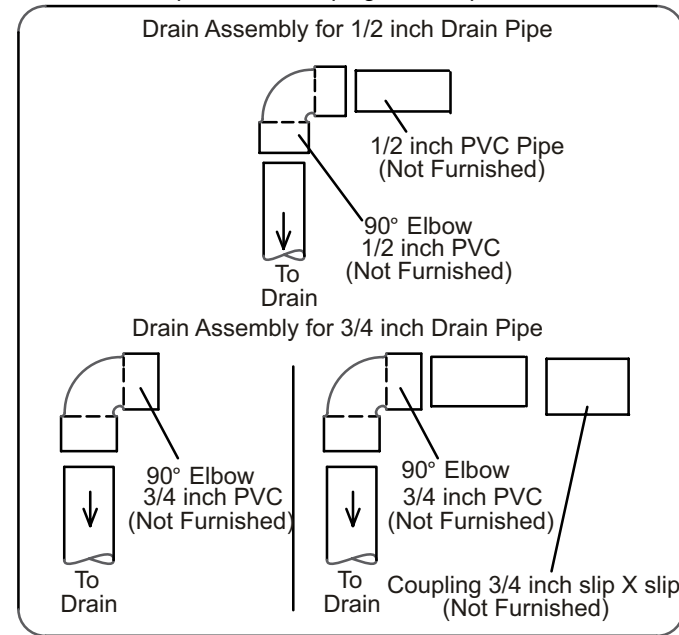

Figure 54. Furnace with Evaporator Coil Using a Common Drain

Optional Condensate Drain Connection



Optional Drain Piping From Trap



Drain Trap Assembly (Furnished)

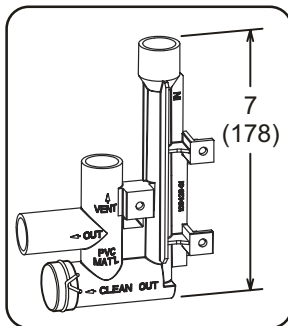

Drain Trap Assembly with 1/2 inch Piping

1 (25 mm) Min. 2 (50 mm) Max. Above Top Of Condensate Drain Connection In Unit

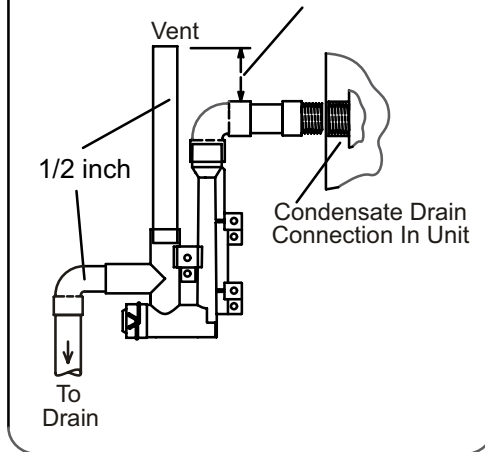

Drain Trap Assembly with 3/4 inch Piping

1 (25 mm) Min. 2 (50 mm) Max. Above Top Of Condensate Drain Connection In Unit

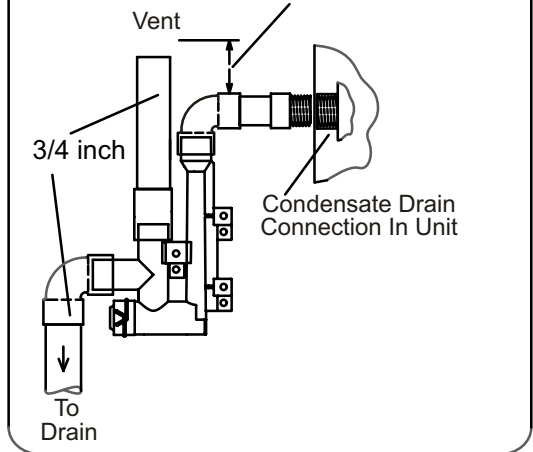

Figure 55. Trap / Drain Assembly Using 1/2" PVC or 3/4" PVC

Gas Piping

Gas supply piping should not allow more than 0.5" W.C. drop in pressure between gas meter and unit. Supply gas pipe must not be smaller than unit gas connection.

⚠ CAUTION

If a flexible gas connector is required or allowed by the authority that has jurisdiction, black iron pipe shall be installed at the gas valve and extend outside the furnace cabinet. The flexible connector can then be added between the black iron pipe and the gas supply line.

⚠ WARNING

Do not over torque (800 in-lbs) or under torque (350 in-lbs) when attaching the gas piping to the gas valve.

1. Gas piping may be routed into the unit through the right-hand side only. Supply piping enters into the gas valve from the side of the valve as shown in Figure 57. Connect the gas supply piping into the gas valve. The maximum torque is 800 in lbs and minimum torque is 350 in lbs when when attaching the gas piping to the gas valve.

2. When connecting gas supply, factors such as length of run, number of fittings and furnace rating must be considered to avoid excessive pressure drop. Table 9 lists recommended pipe sizes for typical applications.

NOTE: Use two wrenches when connecting gas piping to avoid transferring torque to the manifold.

3. Gas piping must not run in or through air ducts, clothes chutes, chimneys or gas vents, dumb waiters or elevator shafts. Center gas line through piping hole. Gas line should not touch side of unit. See Figure 57 and Figure 58.

4. Piping should be sloped 1/4 inch per 15 feet (6mm per 5.6m) upward toward the gas meter from the furnace. The piping must be supported at proper intervals, every 8 to 10 feet (2.44 to 3.05m), using suitable hangers or straps. Install a drip leg in vertical pipe runs to serve as a trap for sediment or condensate.

5. A 1/8" N.P.T. plugged tap or pressure post is located on the gas valve to facilitate test gauge connection. See Figure 62.

6. In some localities, codes may require installation of a manual main shut-off valve and union (furnished by installer) external to the unit. Union must be of the ground joint type.

⚠ IMPORTANT

Compounds used on threaded joints of gas piping must be resistant to the actions of liquified petroleum gases.

Leak Check

After gas piping is completed, carefully check all field-installed piping connections for gas leaks. Use a commercially available leak detecting solution specifically manufactured for leak detection. Never use an open flame to test for gas leaks.

The furnace must be isolated from the gas supply system by closing the individual manual shut-off valve during any gas supply system at pressures greater than or equal to 1/2 psig (3.48 kPa, 14 inches w.c.). This furnace and its components are designed, manufactured and independently certified to comply with all applicable ANSI/CSA standards. A leak check of the furnace and its components is not required.

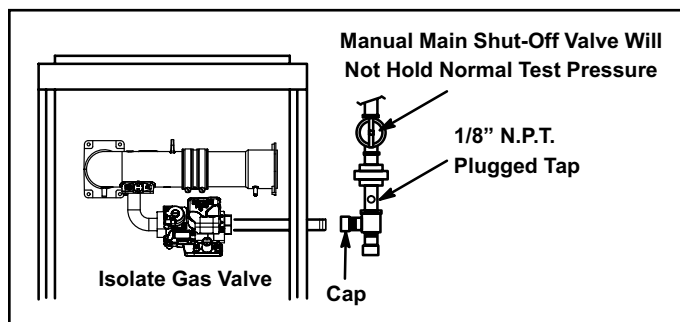

Figure 56.

⚠ IMPORTANT

When testing pressure of gas lines, gas valve must be disconnected and isolated. See Figure 56. Gas valves can be damaged if subjected to pressures greater than 1/2 psig (3.48 kPa).

⚠ WARNING

FIRE OR EXPLOSION HAZARD

Failure to follow the safety warnings exactly could result in serious injury, death, or property damage. Never use an open flame to test for gas leaks. Check all connections using a commercially available soap solution made specifically for leak detection. Some soaps used for leak detection are corrosive to certain metals. Carefully rinse piping thoroughly after leak test has been completed.

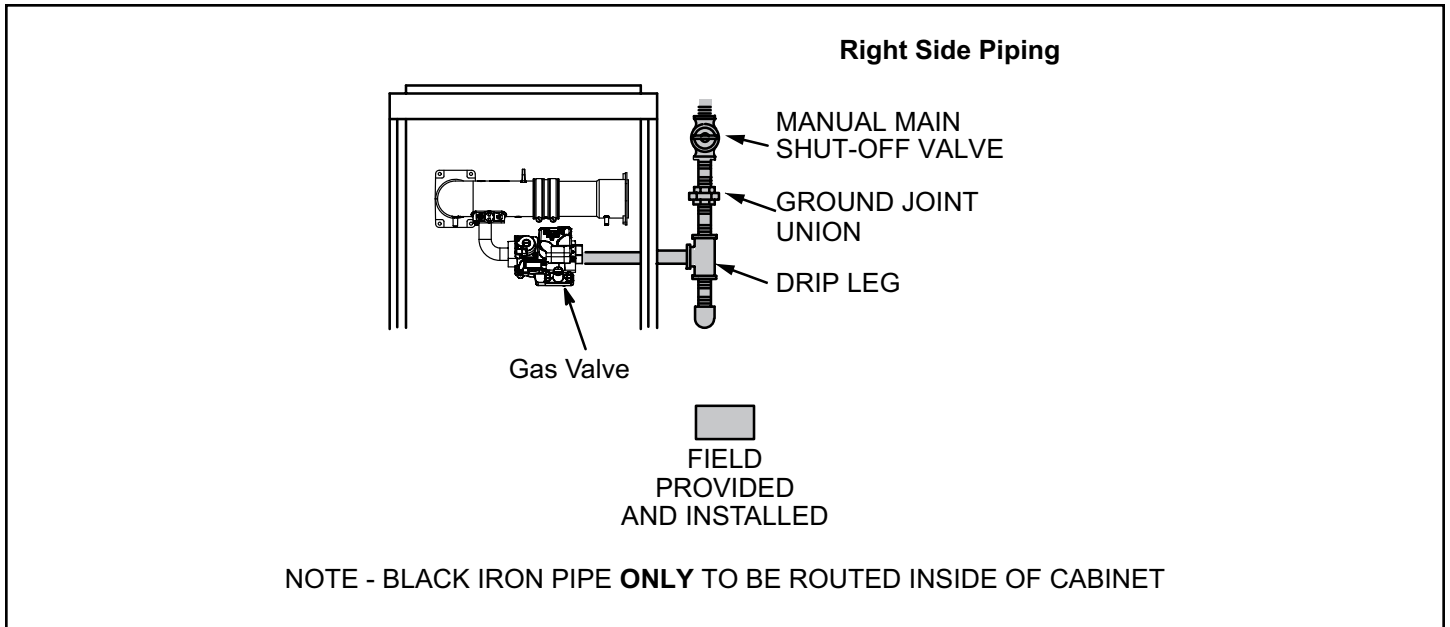

Figure 57. Possible Gas Piping Configurations - Upflow Applications

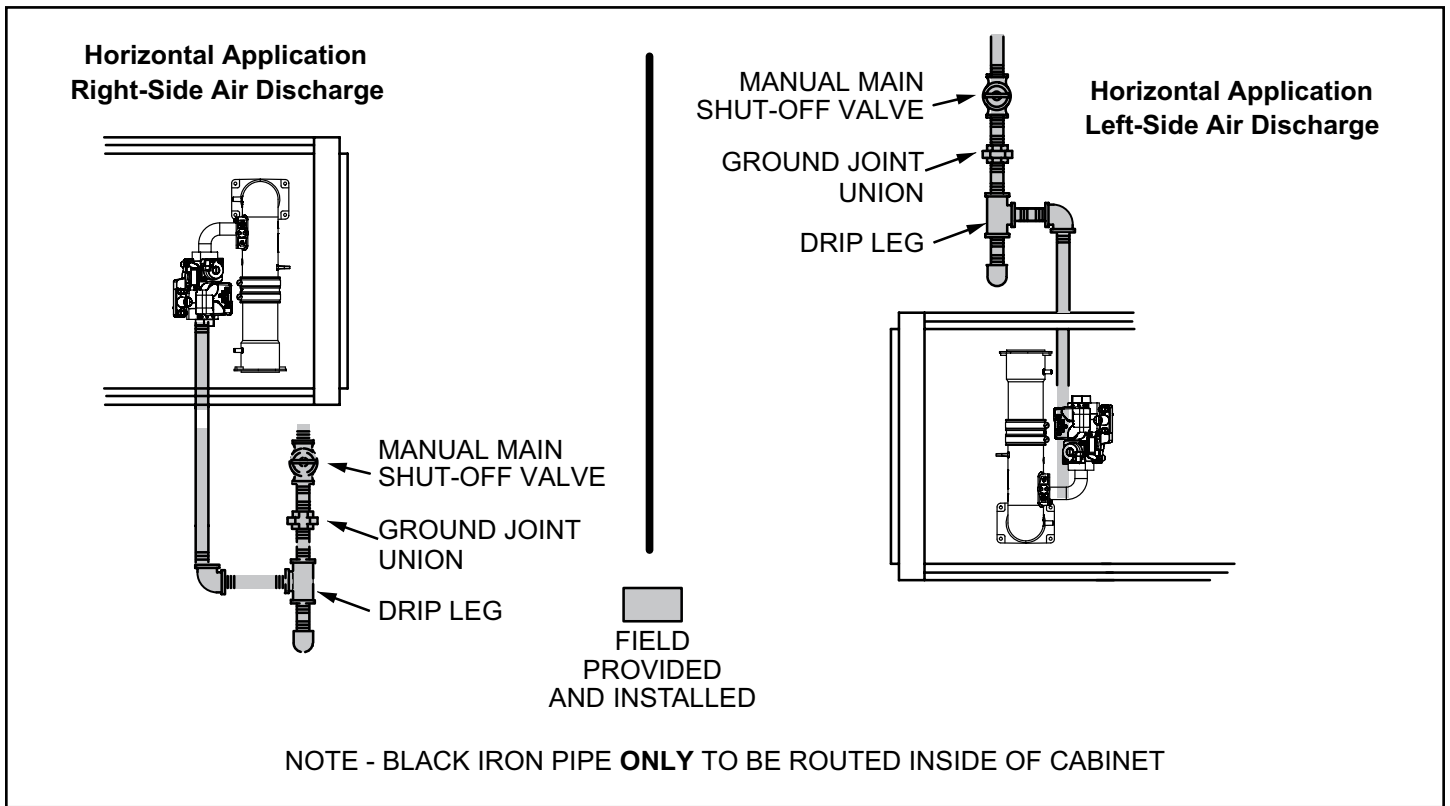

Figure 58. Possible Gas Piping Configurations - Horizontal Applications

Removal of the Furnace from Common Vent

In the event that an existing furnace is removed from a venting system commonly run with separate gas appliances, the venting system is likely to be too large to properly vent the remaining attached appliances.

Conduct the following test while each appliance is operating and the other appliances (which are not operating) remain connected to the common venting system. If the venting system has been installed improperly, you must correct the system as indicated in the general venting requirements section.

Gas Pipe Capacity - FT ³ /HR (KL/HR)											
Nominal Iron Pipe Size - inches (mm)	Internal Diameter - inches (mm)	Length or Pipe - feet (m)									
		10 (3.048)	20 (6.096)	30 (9.144)	40 (12.192)	50 (15.240)	60 (18.288)	70 (21.336)	80 (24.384)	90 (27.432)	100 (30.480)
1/2 (12.7)	.622 (17.799)	172 (4.87)	118 (3.34)	95 (2.69)	81 (2.29)	72 (2.03)	65 (1.84)	60 (1.69)	56 (1.58)	52 (1.47)	50 (1.42)
3/4 (19.05)	.824 (20.930)	360 (10.19)	247 (7.00)	199 (5.63)	170 (4.81)	151 (4.28)	138 (3.87)	126 (3.56)	117 (3.31)	110 (3.11)	104 (2.94)
1 (25.4)	1.049 (26.645)	678 (19.19)	466 (13.19)	374 (10.59)	320 (9.06)	284 (8.04)	257 (7.27)	237 (6.71)	220 (6.23)	207 (5.86)	195 (5.52)
1-1/4 (31.75)	1.380 (35.052)	1350 (38.22)	957 (27.09)	768 (22.25)	657 (18.60)	583 (16.50)	528 (14.95)	486 (13.76)	452 (12.79)	424 (12.00)	400 (11.33)
1-1/2 (38.1)	1.610 (40.894)	2090 (59.18)	1430 (40.49)	1150 (32.56)	985 (27.89)	873 (24.72)	791 (22.39)	728 (20.61)	677 (19.17)	635 (17.98)	600 (17.00)
2 (50.8)	2.067 (52.502)	4020 (113.83)	2760 (78.15)	2200 (62.30)	1900 (53.80)	1680 (47.57)	1520 (43.04)	1400 (39.64)	1300 (36.81)	1220 (34.55)	1160 (32.84)
2-1/2 (63.5)	2.469 (67.713)	6400 (181.22)	4400 (124.59)	3530 (99.95)	3020 (85.51)	2680 (75.88)	2480 (70.22)	2230 (63.14)	2080 (58.89)	1950 (55.22)	1840 (52.10)

NOTE: Capacity given in cubic feet of gas per hour (kilo liters of gas per hour) and based on 0.60 specific gravity gas.

Table 9.

⚠ WARNING

CARBON MONOXIDE POISONING HAZARD

Failure to follow the steps outlined below for each appliance connected to the venting system being placed into operation could result in carbon monoxide poisoning or death.

The following steps shall be followed for each appliance connected to the venting system being placed into operation, while all other appliances connected to the venting system are not in operation:

1. Seal any unused openings in the common venting system.
2. Inspect the venting system for proper size and horizontal pitch. Determine that there is no blockage, restriction, leakage, corrosion, or other deficiencies which could cause an unsafe condition.
3. Close all building doors and windows and all doors between the space in which the appliances remaining connected to the common venting system are located and other spaces of the building. Turn on clothes

- dryers and any appliances not connected to the common venting system. Turn on any exhaust fans, such as range hoods and bathroom exhausts, so they will operate at maximum speed. Do not operate a summer exhaust fan. Close fireplace dampers.
4. Follow the lighting instructions. Turn on the appliance that is being inspected. Adjust the thermostat so that the appliance operates continuously.
 5. After the main burner has operated for 5 minutes, test for leaks of flue gases at the draft hood relief opening. Use the flame of a match or candle.
 6. After determining that each appliance connected to the common venting system is venting properly, (step 3) return all doors, windows, exhaust fans, fireplace dampers, and any other gas-burning appliances to their previous mode of operation.
 7. If a venting problem is found during any of the preceding tests, the common venting system must be modified to correct the problem.

Resize the common venting system to the minimum vent pipe size determined by using the appropriate tables in Appendix G. These are in the current standards of the National Fuel Gas Code ANSI Z223.1.

Electrical

ELECTROSTATIC DISCHARGE (ESD)

Precautions and Procedures

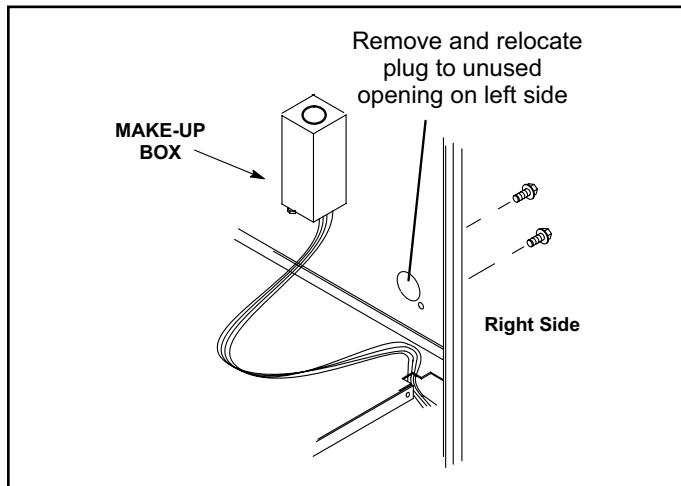
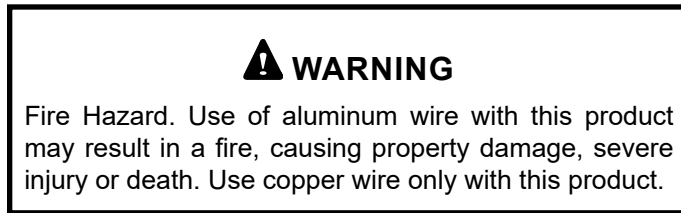
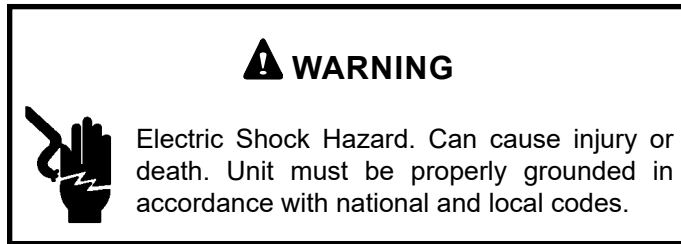
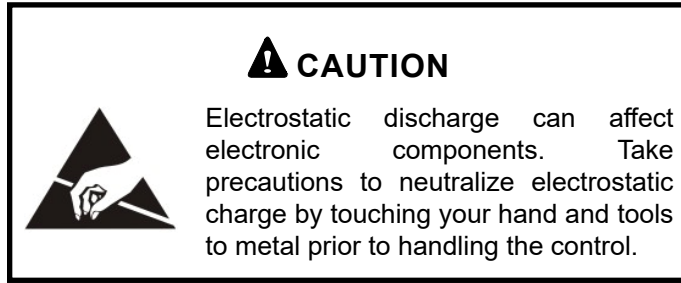

Figure 59. Interior Make-Up Box Installation

The unit is equipped with a field make-up box. The make-up box may be moved to the right side of the furnace to facilitate installation. Secure the excess wire to the existing harness to protect it from damage.

Refer to Figure 61 for field wiring, schematic wiring diagram and troubleshooting.

The power supply wiring must meet Class I restrictions. Protected by either a fuse or circuit breaker, select circuit protection and wire size according to unit nameplate.

NOTE: Unit nameplate states maximum current draw. Maximum Over-Current Protection allowed is 15 AMP.



Holes are on both sides of the furnace cabinet to facilitate wiring.

Install a separate (properly sized) disconnect switch near the furnace so that power can be turned off for servicing.

Before connecting the thermostat check to make sure the wires will be long enough for servicing at a later date. Make sure that thermostat wire is long enough to facilitate future removal of blower for service.

Complete the wiring connections to the equipment. Use the provided unit wiring diagram and the field wiring diagram shown in Figure 61. Use 18-gauge wire or larger that is suitable for Class II rating for thermostat connections.

Electrically ground the unit according to local codes or, in the absence of local codes, according to the current National Electric Code (ANSI/NFPA No. 70) for the USA and current Canadian Electric Code part 1 (CSA standard C22.1) for Canada. A green ground wire is provided in the field make-up box.

NOTE: The 95G1UHEX furnace contains electronic components that are polarity sensitive. Make sure that the furnace is wired correctly and is properly grounded.

Accessory Terminals

One line voltage "EAC" 1/4" spade terminal is provided on the furnace integrated control. See Figure 60 for integrated control configuration. This terminal is energized when the indoor blower is operating. Any accessory rated up to one amp can be connected to this terminal with the neutral leg of the circuit being connected to one of the provided neutral terminals. If an accessory rated at greater than one amp is connected to this terminal, it is necessary to use an external relay.

One line voltage "120 HUM" 1/4" spade terminal is provided on the furnace integrated control. See Figure 60 for integrated control configuration. This terminal is energized in the heating mode when the combustion air inducer is operating. Any humidifier rated up to one amp can be

connected to this terminal with the neutral leg of the circuit being connected to one of the provided neutral terminals. If a humidifier rated at greater than one amp is connected to this terminal, it is necessary to use an external relay relay.

One 24V “H” 1/4” spade terminal is provided on the furnace integrated control. See Figure 60 for integrated control configuration. The terminal is energized in the heating mode when the combustion air inducer is operating and the pressure switch is closed. Any humidifier rated up to 0.5 amp can be connected to this terminal with the ground leg of the circuit connected to ground or the “C” terminal.

Install the room thermostat according to the instructions provided with the thermostat. See Figure 61 for thermostat designations. If the furnace is being matched with a heat pump, refer to the FM21 installation instruction or appropriate dual fuel thermostat instructions.

Indoor Blower Speeds

1. When the thermostat is set to “FAN ON,” the indoor blower will run continuously on the fan speed (FAN) when there is no cooling or heating demand. See Table 12 for allowable continuous circulation speeds.
2. When the 95G1UHEX is running in the heating mode, the indoor blower will run on the heating speed (HEAT).
3. When there is a cooling demand, the indoor blower will run on the cooling speed (COOL).

Generator Use - Voltage Requirements

The following requirements must be kept in mind when specifying a generator for use with this equipment:

- The furnace requires 120 volts + 10% (Range: 108 volts to 132 volts).
- The furnace operates at 60 Hz + 5% (Range: 57 Hz to 63 Hz).
- The furnace integrated control requires both polarity and proper ground. Both polarity and proper grounding should be checked before attempting to operate the furnace on either permanent or temporary power.
- Generator should have a wave form distortion of less than 5% THD (total harmonic distortion).

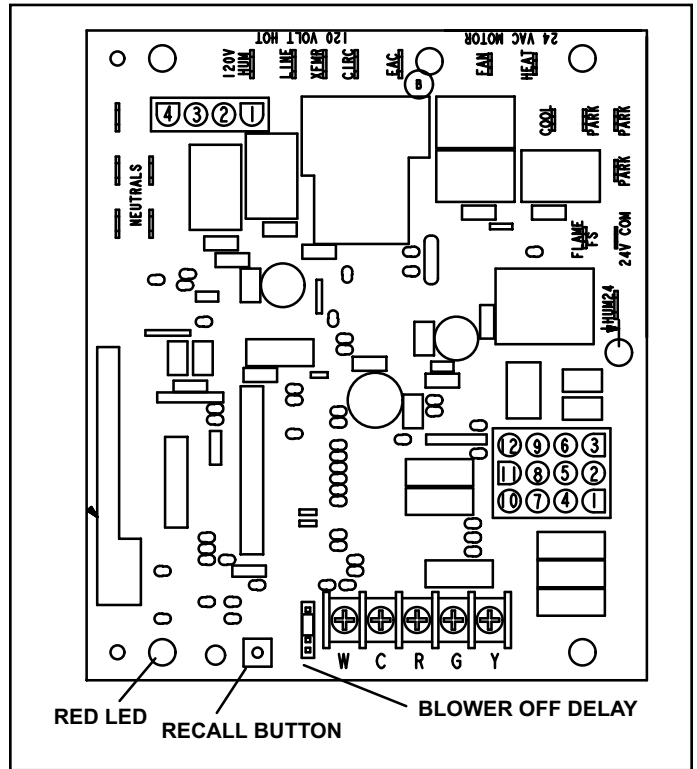

Figure 60. Integrated Control (Automatic Hot Surface Ignition System)

1/4" Quick Connect Terminals	
120HUM	Humidifier 120VAC
LINE	120VAC
XFMR	Transformer 120VAC
CIRC	Indoor blower 120VAC
EAC	Indoor air quality accessory 120VAC
NEUTRALS	Common 120VAC
HUM24	Humidifier 24VAC
3/16" Quick Connect Terminals	
COOL	Cooling tap 24VAC
HEAT	Heating tap 24VAC
FAN	Continuous blower 24VAC
PARK (no power)	Park terminal for speed taps
FS	Flame sense
24 COM	Common 24VAC

Table 10.

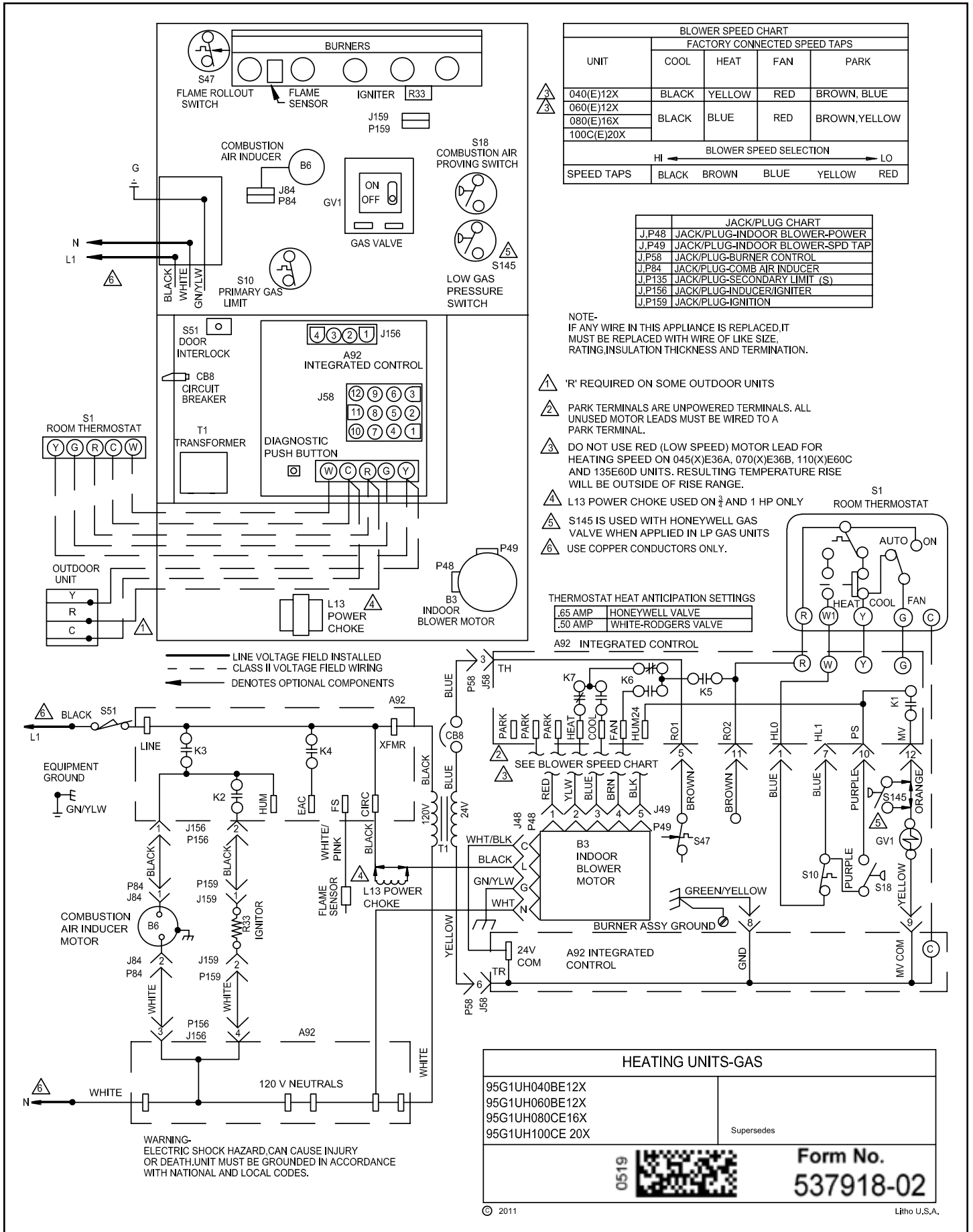

Figure 61.

Blower Performance

95G1UH040BE12X Performance (Less Filter)

External Static Pressure in. w.c.	Air Volume / Watts at Various Blower Speeds									
	High		Medium-High		Medium		Medium-Low		Low	
	cfm	Watts	cfm	Watts	cfm	Watts	cfm	Watts	cfm	Watts
0.00	1450	350	1280	247	1190	200	966	112	902	89
0.10	1429	360	1268	257	1171	207	939	119	875	99
0.20	1400	371	1248	267	1139	212	894	124	850	110
0.30	1377	381	1222	279	1112	223	872	131	800	114
0.40	1350	391	1195	286	1084	235	829	138	778	122
0.50	1317	401	1156	298	1043	240	794	147	724	129
0.60	1285	408	1127	308	1019	252	754	151	690	142
0.70	1233	390	1107	316	987	259	708	161	633	144
0.80	1160	370	1077	322	955	270	661	167	607	149

95G1UH060BE12X Performance (Less Filter)

External Static Pressure in. w.c.	Air Volume / Watts at Various Blower Speeds									
	High		Medium-High		Medium		Medium-Low		Low	
	cfm	Watts	cfm	Watts	cfm	Watts	cfm	Watts	cfm	Watts
0.00	1477	338	1289	240	1189	188	940	99	905	88
0.10	1431	353	1262	254	1160	200	918	109	873	97
0.20	1401	360	1244	263	1135	209	894	121	839	108
0.30	1372	374	1215	270	1110	221	852	126	798	113
0.40	1352	387	1189	282	1074	226	821	136	772	123
0.50	1324	391	1165	292	1050	241	786	146	728	130
0.60	1296	403	1130	302	1011	252	741	150	691	140
0.70	1255	406	1102	313	988	258	703	161	641	144
0.80	1190	386	1073	326	962	267	664	167	606	153

95G1UH080CE16X Performance (Less Filter)

External Static Pressure in. w.c.	Air Volume / Watts at Various Blower Speeds									
	High		Medium-High		Medium		Medium-Low		Low	
	cfm	Watts	cfm	Watts	cfm	Watts	cfm	Watts	cfm	Watts
0.00	1702	381	1502	270	1375	195	1298	169	1189	132
0.10	1688	418	1479	287	1349	220	1258	187	1136	144
0.20	1660	443	1450	304	1321	242	1215	203	1084	158
0.30	1627	458	1403	321	1282	255	1172	215	1030	172
0.40	1577	475	1370	337	1234	272	1131	231	990	188
0.50	1540	483	1329	352	1191	288	1085	245	933	195
0.60	1441	457	1291	369	1146	301	1045	259	883	203
0.70	1293	402	1249	380	1102	315	992	271	830	216
0.80	1144	365	1122	351	1053	326	951	285	809	219

95G1UH100CE20X Performance (Less Filter)

External Static Pressure in. w.c.	Air Volume / Watts at Various Blower Speeds																													
	Bottom Return Air, Side Return Air with Return Air from Both Sides or Return Air from Bottom and One Side.									Single Side Return Air - Air volumes in bold require Optional Return Air Base and field fabricated transition to accommodate 20 x 25 x 1 in. air filter in order to maintain proper air velocity.																				
	High			Medium-High			Medium			Medium-Low			Low			High			Medium-High			Medium			Medium-Low			Low		
	cfm	Watts	cfm	Watts	cfm	Watts	cfm	Watts	cfm	Watts	cfm	Watts	cfm	Watts	cfm	Watts	cfm	Watts	cfm	Watts	cfm	Watts	cfm	Watts	cfm	Watts	cfm	Watts		
0.00	2156	722	1922	497	1723	370	1589	215	1420	211	2102	118	1833	1688	170	1590	300	1375	209											
0.10	2112	738	1851	511	1681	388	1552	326	1380	227	2064	730	1809	1658	384	1540	314	1347	224											
0.20	2076	748	1808	533	1636	403	1525	334	1340	244	2038	749	1789	1623	402	1507	331	1325	242											
0.30	2035	768	1782	542	1604	425	1488	349	1290	259	2011	760	1761	1594	413	1472	348	1266	246											
0.40	2009	772	1749	558	1572	433	1441	362	1248	266	1968	770	1726	1561	431	1435	355	1247	264											
0.50	1942	776	1715	580	1533	452	1424	374	1213	281	1920	776	1685	1527	443	1394	374	1199	278											
0.60	1881	746	1681	584	1512	468	1357	382	1157	293	1849	741	1660	1489	455	1356	379	1154	286											
0.70	1790	715	1634	599	1459	474	1319	401	1136	306	1777	723	1622	1439	473	1317	395	1124	301											
0.80	1702	679	1582	613	1432	491	1300	418	1084	312	1682	681	1588	1407	488	1288	408	1067	308											

Allowable Heating Speeds					
Model	Red	Yellow	Blue	Brown	Black
95G1UH040BE12X	Allowed	Factory Setting	Allowed	Not Allowed	Not Allowed
95G1UH060BE12X	Allowed	Allowed	Factory Setting	Allowed	Not Allowed
95G1UH080CE16X	Allowed	Allowed	Factory Setting	Allowed	Not Allowed
95G1UH100CE20X	Allowed	Allowed	Factory Setting	Not Allowed	Not Allowed

Table 11.

Allowable Circulation Speeds					
Model	Red	Yellow	Blue	Brown	Black
All Models	Factory Setting	Not Allowed	Not Allowed	Not Allowed	Not Allowed

Table 12.

RED LED Flash Code ²	Diagnostic Codes / Status of Furnace
Off	No power to control or board fault detected
Heartbeat ¹	Normal Operation - Idle, Continuous Fan, Cool
Continuous Rapid Flash	Call For Heat / Burner Operation
1	Reverse Line Voltage Polarity
2	Improper Earth Ground
3	Burner failed to light, or lost flame during heat demand
4	Low Flame Signal - check flame sensor
5	Watchguard - burner failed to light, exceeded maximum number of retries or recycles.
6	Ignitor Circuit Failure - not available on this control
7	Primary or Secondary Limit Open or Watchguard Mode - Limit Switch Open longer than 3 minutes
8	Rollout Switch Open
9	Pressure Switch failed to close or opened during heat demand
10	Watchguard - Pressure Switch opened 5 times during one heat demand
11	Pressure Switch stuck closed prior to activation of combustion air inducer
12	Flame Sensed without gas valve energized
13	Low Line Voltage

NOTE: A "Heartbeat" is indicated by a "Slow Flash" - 1 sec on 1 sec off, repeating

NOTE: Error codes are indicated by a "rapid flash" - the LED flashes X times at ½ second on ½ second off, remains off for 3 seconds then repeats.

NOTE: Last 10 error codes are stored in memory including when power is shut off to the unit. - To recall, press and release button, most recent will be displayed first, LED off for 3 sec, then next error code is displayed, etc. To clear error codes, depress and hold button longer than 5 seconds.

Unit Start-Up

FOR YOUR SAFETY READ BEFORE OPERATING

⚠ WARNING

Do not use this furnace if any part has been underwater. A flood-damaged furnace is extremely dangerous. Attempts to use the furnace can result in fire or explosion. Immediately call a qualified service technician to inspect the furnace and to replace all gas controls, control system parts, and electrical parts that have been wet or to replace the furnace, if deemed necessary.

⚠ WARNING



Danger of explosion. Can cause injury or product or property damage. Should the gas supply fail to shut off or if overheating occurs, shut off the gas valve to the furnace before shutting off the electrical supply.

⚠ CAUTION

Before attempting to perform any service or maintenance, turn the electrical power to unit OFF at disconnect switch.

BEFORE LIGHTING the unit, smell all around the furnace area for gas. Be sure to smell next to the floor because some gas is heavier than air and will settle on the floor.

The gas valve on the 95G1UHEX is equipped with a gas control switch (lever). Use only your hand to move switch. Never use tools. If the the switch will not move by hand, do not try to repair it. Force or attempted repair may result in a fire or explosion.

Placing the Furnace into Operation

95G1UHEX units are equipped with an automatic hot surface ignition system. Do not attempt to manually light burners on this furnace. Each time the thermostat calls for heat, the burners will automatically light. The ignitor does not get hot when there is no call for heat on these units.

Priming Condensate Trap

The condensate trap should be primed with water prior to start-up to ensure proper condensate drainage. Either pour 10 fl. oz. (300 ml) of water into the trap, or follow these steps to prime the trap:

1. Follow the lighting instructions to place the unit into operation.
2. Set the thermostat to initiate a heating demand.

3. Allow the burners to fire for approximately 3 minutes.
4. Adjust the thermostat to deactivate the heating demand.
5. Wait for the combustion air inducer to stop. Set the thermostat to initiate a heating demand and again allow the burners to fire for approximately 3 minutes.
6. Adjust the thermostat to deactivate the heating demand and wait for the combustion air inducer to stop. At this point, the trap should be primed with sufficient water to ensure proper condensate drain operation.

⚠ WARNING

If you do not follow these instructions exactly, a fire or explosion may result causing property damage, personal injury or death.

Gas Valve Operation

See Figure 62

1. **STOP!** Read the safety information at the beginning of this section.
2. Set the thermostat to the lowest setting.
3. Turn off all electrical power to the unit.
4. This furnace is equipped with an ignition device which automatically lights the burners. Do not try to light the burners by hand.
5. Remove the access panel.
6. Move gas valve switch to OFF. See Figure 62.
7. Wait five minutes to clear out any gas. If you then smell gas, **STOP!** Immediately call your gas supplier from a neighbor's phone. Follow the gas supplier's instructions. If you do not smell gas go to next step.
8. Move gas valve switch to ON. See Figure 62.
9. Replace the access panel.
10. Turn on all electrical power to to the unit.

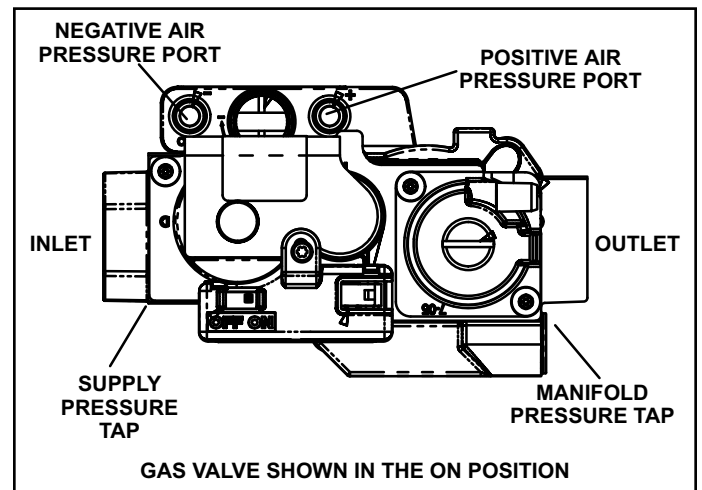

Figure 62. Gas Valve

11. Set the thermostat to desired setting.
NOTE: When unit is initially started, steps 1 through 11 may need to be repeated to purge air from gas line.
12. If the appliance will not operate, follow the instructions "Turning Off Gas to Unit" and call your service technician or gas supplier.

Turning Off Gas to Unit

1. Set the thermostat to the lowest setting.
2. Turn off all electrical power to the unit if service is to be performed.
3. Remove the access panel.
4. Move gas valve switch to OFF.
5. Replace the access panel.

Failure to Operate

If the unit fails to operate, check the following:

1. Is the thermostat calling for heat?
2. Are access panels securely in place?
3. Is the main disconnect switch closed?
4. Is there a blown fuse or tripped breaker?
5. Is the filter dirty or plugged? Dirty or plugged filters will cause the limit control to shut the unit off.
6. Is gas turned on at the meter?

7. Is the manual main shut-off valve open?
8. Is the internal manual shut-off valve open?
9. Is the unit ignition system in lockout? If the unit locks out again, inspect the unit for blockages.

Heating Sequence of Operation

1. When thermostat calls for heat, combustion air inducer starts.
2. Combustion air pressure switch proves blower operation. Switch is factory set and requires no adjustment.
3. After a 15-second prepurge, the hot surface ignitor energizes.
4. After a 20-second ignitor warm-up period, the gas valve solenoid opens. A 4-second trial for ignition period begins."
5. Gas is ignited, flame sensor proves the flame, and the combustion process continues.
6. If flame is not detected after first ignition trial, the ignition control will repeat steps 3 and 4 four more times before locking out the gas valve ("WATCHGUARD" flame failure mode). The ignition control will then automatically repeat steps 1 through 6 after 60 minutes. To interrupt the 60-minute "WATCHGUARD" period, move thermostat from "Heat" to "OFF" then back to "Heat". Heating sequence then restarts at step 1.

Gas Pressure Adjustment

Gas Flow (Approximate)

Model	Seconds for One Revolution			
	Natural		LP	
	1 cu ft Dial	2 cu ft Dial	1 cu ft Dial	2 cu ft Dial
-040	90	180	-	-
-060	60	120	150	300
-080	45	90	112	224
-100	36	72	-	-
Natural - 1000 btu/cu ft			LP - 2500 btu/cu ft	

Table 13. Gas Meter Clocking Chart

Furnace should operate at least 5 minutes before checking gas flow. Determine time in seconds for two revolutions of gas through the meter. Two revolutions assures a more accurate time. Divide by two and compare to time in Table 13. If manifold pressure matches Table 14 and rate is incorrect, check gas orifices for proper size and restriction. Remove temporary gas meter if installed.

NOTE: To obtain accurate reading, shut off all other gas appliances connected to meter.

Supply Pressure Measurement

A threaded plug on the inlet side of the gas valve provides access to the supply pressure tap. Remove the threaded plug, install a field-provided barbed fitting and connect a manometer to measure supply pressure.

On multiple unit installations, each unit should be checked separately, with and without units operating. Supply pressure must fall within range listed in Table 14.

Check Manifold Pressure

To correctly measure manifold pressure, follow the steps below.

1. Remove the threaded plug from the outlet side of the gas valve and install a field-provided barbed fitting. Connect measuring device "+" connection to barbed fitting to measure manifold pressure.
2. Start unit and allow 5 minutes for unit to reach steady state.
3. After allowing unit to stabilize for 5 minutes, record manifold pressure and compare to value given in Table 14.

4. Shut unit off and remove manometer as soon as an accurate reading has been obtained. Take care to remove barbed fitting and replace threaded plug.
5. Start unit and perform leak check. Seal leaks if found.

⚠ IMPORTANT

For safety, connect a shut-off valve between the manometer and the gas tap to permit shut off of gas pressure to the manometer.

Altitude	Unit	Natural		LP / Propane	
		Manifold	Supply	Manifold	Supply
0 - 4,500 ft.	040	3.5	4.5 - 10.5	n/a	n/a
	060			3.6	11.0 - 13.0
	080				
	100			n/a	n/a
4,501 - 7,500 ft.	040	3.2	4.5 - 10.5	n/a	n/a
	060	2.3		2.5	11.0 - 13.0
	080	2.4		2.8	
	100	2.3		n/a	n/a

Table 14. Supply Line and Manifold Pressure (inches w.c.)

Proper Combustion

Furnace should operate minimum 15 minutes with correct manifold pressure and gas flow rate before checking combustion. Take combustion sample beyond the flue outlet and compare to Table 15.

Model	CO ₂ % for Nat	CO ₂ % for LP
-040	6.3 - 7.8	-
-060	6.5 - 8.2	8.4 - 9.9
-080	7.2 - 8.4	9.0 - 10.4
-100	7.3 - 8.5	-

The maximum carbon monoxide reading should not exceed 100 ppm.

Table 15.

High Altitude Information

Units may be installed at altitudes up to 7,500 ft. above sea level. See Table 14 for de-rate manifold values.

Model	0 - 7,500 ft. (0 - 2286m)
-040	-
-060	19U44
-080	19U45

Table 16. Propane Conversion Kit

Testing for Proper Venting and Sufficient Combustion Air for Non-Direct Vent Applications

⚠ WARNING

CARBON MONOXIDE POISONING HAZARD!

Failure to follow the steps outlined below for each appliance connected to the venting system being placed into operation could result in carbon monoxide poisoning or death.

The following steps shall be followed for each appliance connected to the venting system being placed into operation, while all other appliances connected to the venting system are not in operation.

After the 95G1UHEX gas furnace has been started, the following test should be conducted to ensure proper venting and sufficient combustion air has been provided to the 95G1UHEX as well as to other gas-fired appliances which are separately vented.

If a 95G1UHEX furnace replaces a Category I furnace which was commonly vented with another gas appliance, the size of the existing vent pipe for that gas appliance must be checked. Without the heat of the original furnace flue products, the existing vent pipe is probably oversized for the single water heater or other appliance. The vent should be checked for proper draw with the remaining appliance.

The test should be conducted while all appliances (both in operation and those not in operation) are connected to the venting system being tested. If the venting system has been installed improperly, or if provisions have not been made for sufficient amounts of combustion air, corrections must be made as outlined in the previous section.

1. Seal any unused openings in the venting system.
2. Visually inspect the venting system for proper size and horizontal pitch. Determine there is no blockage or restriction, leakage, corrosion, or other deficiencies which could cause an unsafe condition.

3. To the extent that it is practical, close all building doors and windows and all doors between the space in which the appliances connected to the venting system are located and other spaces of the building.
4. Close fireplace dampers.
5. Turn on clothes dryers and any appliances not connected to the venting system. Turn on any exhaust fans, such as range hoods and bathroom exhausts, so they will operate at maximum speed. Do not operate a summer exhaust fan.
6. Follow the lighting instruction to place the appliance being inspected into operation. Adjust thermostat so appliance will operate continuously.
7. Use the flame of match or candle to test for spillage of flue gases at the draft hood relief opening after 5 minutes of main burner operation.
8. If improper venting is observed during any of the above tests, the venting system must be corrected or sufficient combustion/make-up air must be provided. The venting system should be re-sized to approach the minimum size as determined by using the appropriate tables in appendix G in the current standards of the National Fuel Gas Code ANSI-Z223.1/NPFA 54 in the U.S.A., and the appropriate Natural Gas and Propane appliances venting sizing tables in the current standard of the CSA-B149 Natural Gas and Propane Installation Codes in Canada.
9. After determining that each appliance remaining connected to the common venting system properly vents when tested as indicated in step 3, return doors, windows, exhaust fans, fireplace dampers and any other gas-burning appliance to their previous condition of use.

Other Unit Adjustments

Primary Limit

The primary limit is located on the heating compartment vestibule panel. This limit is factory set and requires no adjustment.

Rollout Switch

This auto-reset switch is located on the front of the intake air elbow.

Pressure Switch

The pressure switch is located in the heating compartment on the cold end header box. This switch checks for proper combustion air inducer operation before allowing ignition trial. The switch is factory-set and must not be adjusted.

Temperature Rise

After the furnace has been started and supply and return air temperatures have been allowed to stabilize, check the temperature rise. If necessary, adjust the blower speed to maintain the temperature rise within the range shown on the unit nameplate. See Table 11 for allowable heating speeds. Increase the blower speed to decrease the temperature. Decrease the blower speed to increase the temperature rise. Failure to adjust the temperature rise may cause erratic limit operation.

Electrical

1. Check all wiring for loose connections.
2. Check for the correct voltage at the furnace (furnace operating). Correct voltage is 120VAC + 10%.
3. Check amp-draw on the blower motor with blower access panel in place.

Unit Nameplate _____ Actual _____

Exhaust and Air Intake Pipe

1. Check exhaust and air intake connections for tightness and to make sure there is no blockage.
2. Is pressure switch closed? Obstructed exhaust pipe will cause unit to shut off at pressure switch. Check termination for blockages.
3. Obstructed pipe or termination may cause rollout switch to open. Check termination for blockages.

Fan Control

Fan On Delay

The heat fan on time of 30 seconds is not adjustable. The cool fan on delay is 2 seconds and not adjustable.

Fan Off Delay

The heat fan off delay (amount of time that the blower operates after the heat demand has been satisfied) may be adjusted by changing the jumper position across the five pins on the integrated control. The unit is shipped with a factory fan off setting of 90 seconds. The fan off delay affects comfort and is adjustable to satisfy individual applications. Adjust the fan off delay to achieve a supply air temperature between 90° and 110°F at the moment that the blower is de-energized. Longer off delay settings provide lower return air temperatures; shorter settings provide higher return air temperatures. See Figure 63.

The cool fan off delay (amount of time that the blower operates after the cool demand has been satisfied) is 45 seconds and not adjustable.

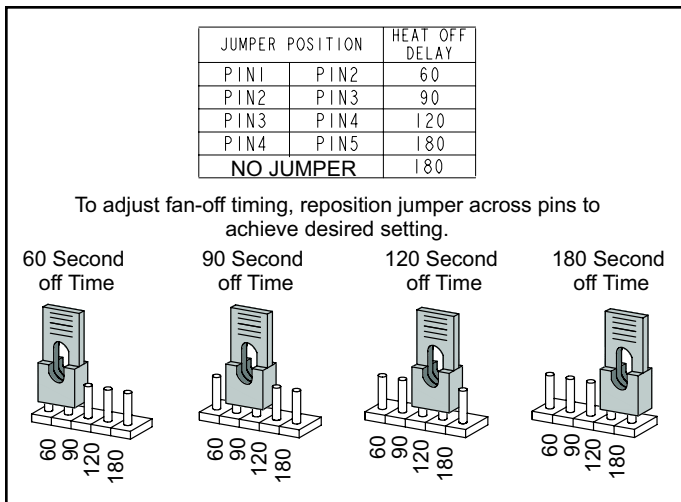

Figure 63. Heat Fan-Off Time in Seconds

Blower Speeds

Follow the steps below to change the blower speeds.

1. Turn off electrical power to furnace.
2. Remove blower access panel.
3. Disconnect existing speed tap at integrated control speed terminal.

NOTE: Termination of any unused motor leads must be insulated.

4. Place unused blower speed tap on integrated control "PARK" terminal or insulate.
5. Refer to blower speed selection chart on unit wiring diagram for desired heating or cooling speed. See Product Specifications for blower performance data. See Table 11 for allowable heating speeds.
6. Connect selected speed tap at integrated control speed terminal.
7. Resecure blower access panel.
8. Turn on electrical power to furnace.
9. Recheck temperature rise.

Electronic Ignition

The integrated control has an added feature of an internal Watchguard control. The feature serves as an automatic reset device for integrated control lockout caused by ignition failure. This type of lockout is usually due to low gas line pressure. After one hour of continuous thermostat demand for heat, the Watchguard will break and remake thermostat demand to the furnace and automatically reset the integrated control to begin the ignition sequence.

Service

⚠ WARNING

ELECTRICAL SHOCK, FIRE, OR EXPLOSION HAZARD.

Failure to follow safety warnings exactly could result in dangerous operation, serious injury, death or property damage.

Improper servicing could result in dangerous operation, serious injury, death, or property damage. Before servicing, disconnect all electrical power to furnace.

When servicing controls, label all wires prior to disconnecting. Take care to reconnect wires correctly. Verify proper operation after servicing.

⚠ WARNING

The blower access panel must be securely in place when the blower and burners are operating. Gas fumes, which could contain carbon monoxide, can be drawn into living space resulting in personal injury or death.

Annual Furnace Maintenance

At the beginning of each heating season, and to comply with the Allied Air Limited Warranty, your system should be checked as follows:

NOTE: Burner inspection and service is not recommended for annual furnace maintenance.

1. Check wiring for loose connections, voltage at indoor unit and amperage of indoor motor.
2. Inspect all gas pipe and connections for leaks.
3. Check the cleanliness of filters and change if necessary (monthly).
4. Check the cleanliness of blower assembly and clean the housing, blower wheel and blower motor if necessary.
5. Inspect the condensate drain and trap for leaks and cracks. Check any additional traps such as in the crawl space exhaust. The drain and trap must also be cleaned and the trap must be primed with water.
6. Remove the rubber hoses from the cold end header box and inspect for any blockage, clean as needed. If strainers are installed in the hoses remember to remove and clean before reinstalling the hoses.
7. Evaluate the heat exchanger and combustion chamber integrity by inspecting the heat exchanger per the AHRI heat exchanger inspection procedure. This procedure can be viewed at www.ahrinet.org.

8. Ensure sufficient combustion air is available to the furnace. Fresh air grilles and louvers (on the unit and in the room where the furnace is installed) must be properly sized, open and unobstructed to provide combustion air.
9. Inspect the furnace intake and exhaust pipes to make sure they are in place, structurally sound, without holes, blockage or leakage and the exhaust pipe is sloped toward the furnace. Inspect terminations to ensure they are free of obstructions and are structurally sound. If applicable, inspect and clean air intake screen. Inspect the furnace return air duct connection to ensure the duct is sealed to the furnace.
10. Inspect the furnace return air duct connection to ensure the duct is sealed to the furnace. Check for air leaks on supply and return ducts and seal where necessary.
11. Check the condition of the furnace cabinet insulation and repair if necessary.
12. Perform a complete combustion analysis during the furnace inspection to ensure proper combustion and operation. Consult Service Literature for proper combustion values.
13. Verify operation of smoke detectors and CO detectors and replace batteries as required.

Perform a general system test. Turn on the furnace to check operating functions such as the start-up and shut-off operation.

1. Check the operation of the ignition system, inspect and clean flame sensor. Check microamps before and after. Check controls and safety devices (gas valve, flame sensor, temperature limits). Consult Service Manual for proper operating range. Thermal Limits should be checked by restricting airflow and not disconnecting the indoor blower. For additional details, please see Service and Application Note H049.
2. Verify that system total static pressure and airflow settings are within specific operating parameters.
3. Clock gas meter to ensure that the unit is operating at the specified firing rate. Check the supply pressure and the manifold pressure. If manifold pressure adjustment is necessary, consult the Service Literature for unit specific information on adjusting gas pressure. Not all gas valves are adjustable. Verify correct temperature rise.

Winterizing and Condensate Trap Care

1. Turn off power to the furnace.
2. Have a shallow pan ready to empty condensate water.
3. Remove the clean out cap from the condensate trap and empty water. Inspect the trap then reinstall the clean out cap.

Repair Parts List

The following repair parts are available through Allied Air dealers. When ordering parts, include the complete furnace model number listed on the CSA nameplate. All service must be performed by a licensed professional installer (or equivalent), service agency, or gas supplier.

Cabinet Parts

- Outer access panel
- Blower access panel
- Top Cap

Control Panel Parts

- Transformer
- Integrated control board
- Door interlock switch

Blower Parts

- Blower wheel
- Motor
- Motor mounting frame
- Blower housing cutoff plate

Heating Parts

- Flame Sensor
- Heat exchanger assembly
- Gas manifold Assembly
- Combustion air inducer
- Gas valve
- Burner assembly
- Pressure switch
- Ignitor
- Primary limit control
- Rollout switch