

AutoBooster™

Increase Deliverable Hot Water Capacity of a Tank Water Heater

Specifications

Electric Tankless Water Heater

Applications

- Electric tank in residential & commercial settings
- Gas tank in residential & commercial settings

Performance Features

- Increase deliverable hot water up to 45%
- Compact design
- Set temperature in increments of +/-1°F
- External controls for adjustable settings
- Digital user interface
- Easy installation on new or existing tank water heater
- No need for additional electrical infrastructure when used with an existing electric water heater
- Field replaceable element
- ETL certified for USA and Canada to UL499
- Warranty, five (5) years limited on leaks, one (1) year parts

Product Specifications

Dimensions:	8" x 11.5" x 3.75"
Weight:	5.8 lb
Voltage:	240
Power:	7.2 kW
Max. Amperage:	30 A
Recommended Wire Size:	10 AWG (provided)
Outlet Temperature Range:	80-140°F
Min. Dynamic Operating Pressure:	25 PSI
Max. Dynamic Operating Pressure:	150 PSI
Water Connections:	Inlet: 3/4" NPT female Outlet: 3/4" NPT male

U.S. Patent #: US20160178234

Suggested Specification

Water heater shall be an Eemax AutoBooster model number HATB007240.

Eemax AutoBooster to be connected to a tank water heater for increased hot water delivery. AutoBooster to utilize existing electrical infrastructure of electric tank water heater. Water Heater Booster compatible with gas tank water heater using dedicated 30 amp breaker. AutoBooster to be mounted in horizontal orientation with inlet on the bottom and outlet on the top. AutoBooster water connections are Inlet 3/4" FNPT, and outlet 3/4" MNPT. AutoBooster may be wall mounted if available space is limited.



NO LEAD*
*The wetted surface of this product contacted by water contains less than 0.25% lead and meets NSF/ANSI 372

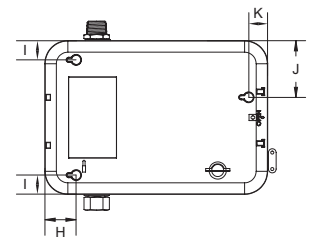
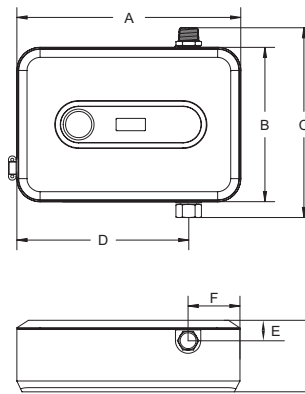

Dimensions	Imperial	Metric
A	11.4-in.	290-mm
B	7.9-in.	200-mm
C	9.7-in.	246-mm
D	8.8-in.	224-mm
E	1.0-in.	26-mm
F	2.7-in.	67-mm
G	3.7-in.	94-mm
H	1.6-in.	41-mm
I	1.0-in.	25-mm
J	2.9-in.	74-mm
K	1.0-in.	25-mm

AutoBooster

Increase Deliverable Hot Water Capacity of Any Tank Water Heater

Specifications

Electric Tankless Water Heater

MODEL NUMBER	kW	AMPS	INLET FITTING	OUTLET FITTING	TURN ON (GPM)	TEMPERATURE RISE °F				
						0.5 GPM	1.0 GPM	1.5 GPM	2.0 GPM	2.5 GPM
VOLTS 240*										
C HATB007240	7.2	30	3/4" FNPT	3/4" MNPT	0.3	98°	49°	33°	25°	20°
C HATB007240 (derated 208V performance)	5.4	26	3/4" FNPT	3/4" MNPT	0.3	74°	37°	25°	18°	15°

* 240V units can be used on 208V single phase with 25% reduced temperature output. Please note per UL standards the rating plate and installation instructions will all be according to a 240V applied voltage. Check with local officials prior to derating the electrical infrastructure.

"C" indicates evaluation and compliance to either Underwriters Laboratories (UL) or Intertek (ETL) under CAN/CSA-C22.2 No. 64/No. 88.

Install on existing electric tank's hot water outlet.

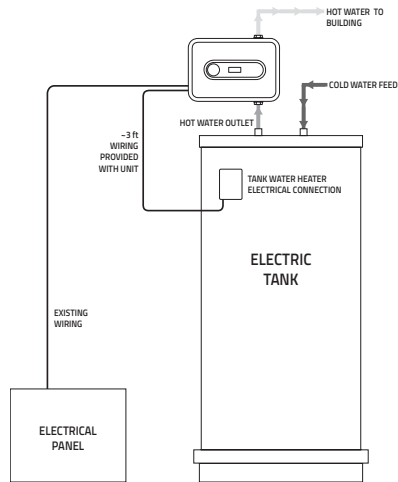

Install on gas tank's hot water outlet.

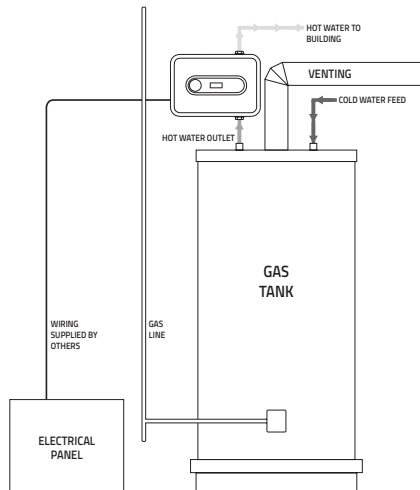

Note: Unit may be wall mounted if available space is limited.