

SharkBite Max™

Ball Valve with Drain & Drop-Ear

SharkBite Max™ allows users to connect pipe with ease - no tools needed. This new design features a stainless steel retainer for extra strength, higher pressure ratings (400 psi) and a lower insertion effort than previous versions of SharkBite Brass Push-to-Connect fittings. SharkBite Max fittings do not require a PEX stiffener and are compatible with PEX, copper, CPVC, PE-RT and HDPE*.

Applications

Residential and commercial potable water, recirculation, hydronic heating/cooling (up to 50% glycol concentration) and direct burial.

Specification Data

Materials	
Body	Lead-Free DZR Brass
O-ring	EPDM
Steel Retainer	304 Stainless Steel
Grab Ring	Stainless Steel
Seal Ring	PTFE
Ball	Chrome Plated Brass
Handle	Steel with PVC Coating
Lock Nut	Stainless Steel
Spindle	Lead-Free DZR Brass

Pipe Insertion Depth		Performance	
Fitting Size	Insertion Depth	Max Working Pressure	
1/2"	1.00 in.	Max Pressure	400 psi
3/4"	1.25 in.	Max Temperature	200°F (93°C)

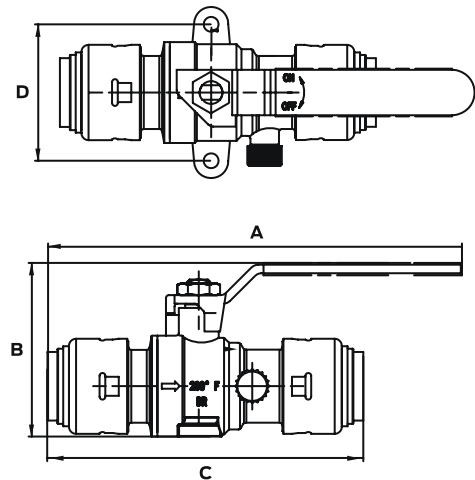

Dimensions (inches)					
Part #	Size	A	B	C	D
UR24615	1/2"	5.4	2.1	3.6	1.5
UR24616	3/4"	5.6	2.4	4.2	1.9

Certifications & Listings

ASME A112.4.14/CSA B125.14, NSF/ANSI 14, NSF/ANSI/CAN 61, NSF/ANSI/CAN 372

For listing information, please contact Customer Service

* HDPE installations must use a tube stiffener. Sold separately by HDPE manufacturer.

Product Submittal	
Name	
Date	
Architect/Owner	
Contractor	
Tag	
Notes	