

**ASHRAE 90.1
COMPLIANT**

3 to 5 Tons
Net Cooling Capacity – 34,600 to 57,000 Btuh
Optional Electric Heat - 5 to 22.5 kW

MODEL NUMBER IDENTIFICATION

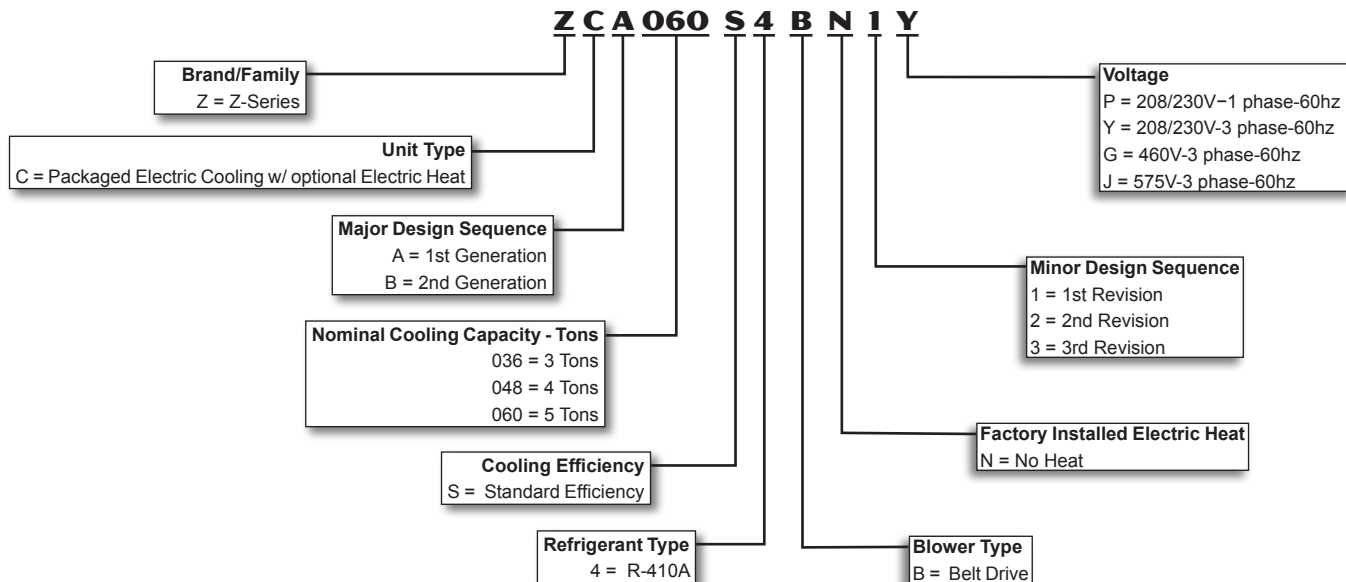

FEATURES AND BENEFITS

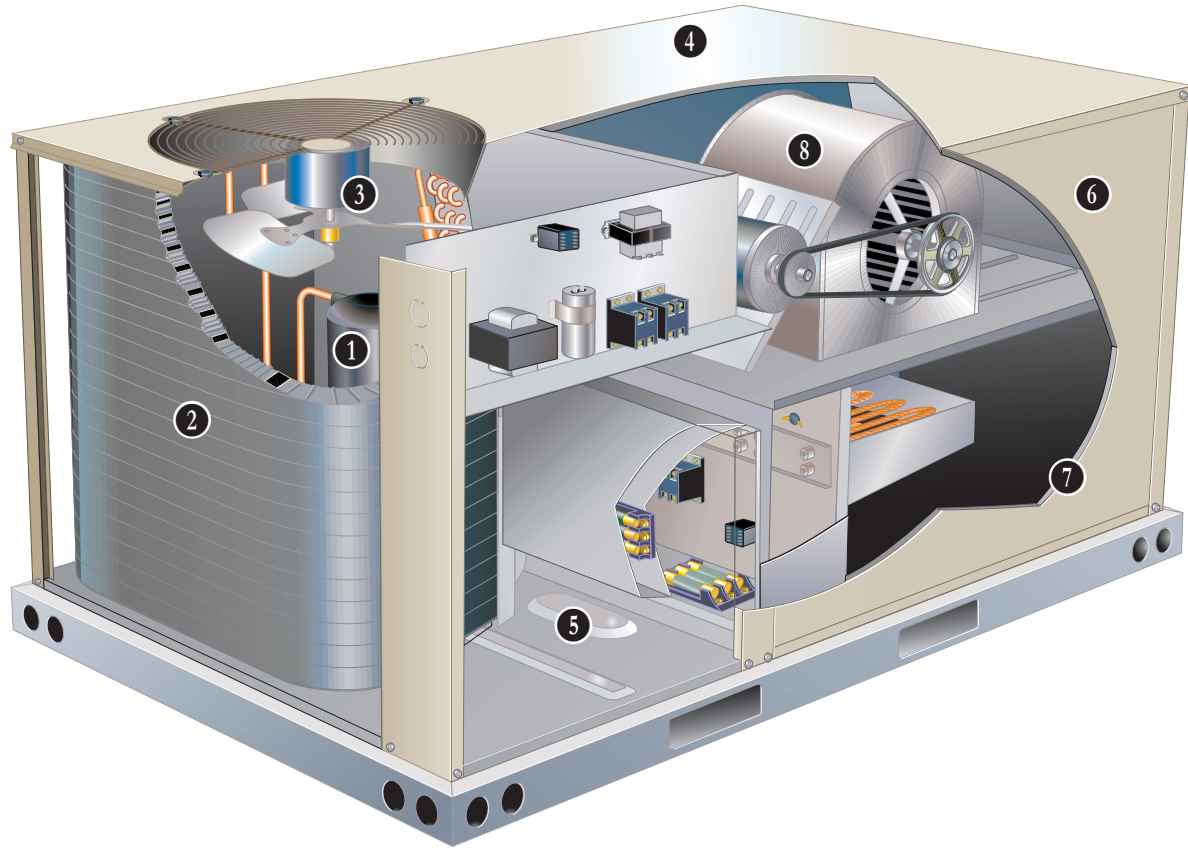

Z-Series rooftop units from Allied are the new standard for cost efficient, reliable rooftop units built for long-lasting performance that can significantly improve indoor environments.

Z-Series rooftop units feature:

- **Quick and Easy Retrofit** - Fast installation for replacement of many existing rooftop units - fits high volume competitor's roof curbs
- **R-410A Refrigerant** - Environmentally friendly
- **Scroll Compressors** - Single speed scroll compressor is furnished on all models.
- **Eco-last™ Coil System** - Smaller, lighter condenser coil.
- **High Pressure Switch** - Protects compressor.
- **Belt Drive Blower Motor** - To maximize air performance.
- **Downflow or Horizontal Airflow** - Easy field conversion.
- **Two Fork Lift Slots on Three Sides** - Easy to pick up and transport units from almost any angle.
- **Corrosion-Resistant Drain Pan** - Provides application flexibility, durability, improved serviceability and meets ASHRAE 62.1 requirements for drain pan slope.

FEATURES AND BENEFITS

CONTENTS

Accessory Dimensions	23
Blower Data	11
Dimensions	22
Electrical Data	15
Electric Heat Capacities	18
Features And Benefits	2
Model Number Identification	1
Options / Accessories	7
Outdoor Sound Data	20
Ratings	10
Specifications	9
Unit Clearances	19
Weight Data	21

APPROVALS

AHRI Certified to AHRI Standard 210/240-2008.

CSA listed.

Units are Certified by CSA.

Components bonded for grounding to meet safety standards for servicing required by UL, ULC and National and Canadian Electrical Codes.

All models are ASHRAE 90.1 compliant.

ISO 9001 Registered

Manufacturing Quality System.

WARRANTY

Limited five years on compressors.

Limited three years on the Eco-last™ Coil System.

Limited one year all other covered components.

COOLING SYSTEM

Designed to maximize sensible and latent cooling performance at design conditions.

System can operate from 35°F to 125°F without any additional controls.

R-410A Refrigerant

Non-chlorine, ozone friendly, R-410A.

Unit is factory pre-charged with refrigerant. See Specifications Table.

1 Compressor

Resiliently mounted on rubber grommets for quiet operation.

Scroll compressors for high performance, reliability and quiet operation.

High Pressure Switch

Protects the compressor from overload conditions such as dirty condenser coils, blocked refrigerant flow, or loss of outdoor fan operation.

Filter/Drier

High capacity filter/drier protects the system from dirt and moisture.

2 Eco-last™ Coil System

Condenser coil features lightweight, all aluminum brazed fin construction.

Constructed of three components:

a flat extrusion tube, fins in-between the flat extrusion tube and two refrigerant manifolds.

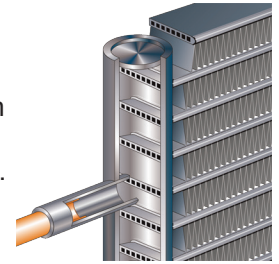

Eco-last™ Coil System Features:

- Improved heat transfer performance due to high primary surface area (flat tubes) versus secondary surface (fins).
- Smaller internal volume (reduced refrigerant charge).
- High durability (all aluminum construction).
- Fewer brazed joints.
- Compact design (reduces unit weight).
- Easy maintenance/cleaning.

Mounting brackets with rubber inserts secure coil to unit providing vibration dampening and corrosion protection

Evaporator Coil

Copper tube construction, enhanced rippled-edge aluminum fins, flared shoulder tubing connections, silver soldered construction for improved heat transfer. Factory leak tested. Cross row circuiting with rifled tubing optimizes both sensible and latent cooling capacity.

Condensate Drain Pan

Plastic pan, sloped to meet drainage requirements of ASHRAE 62.1.

End drain connection.

3 Outdoor Coil Fan Motor

Thermal overload protected, totally enclosed, permanently lubricated bearings, shaft down, fan guard mount.

Outdoor Coil Fan Guard

PVC coated fan guard furnished.

FEATURES AND BENEFITS

COOLING SYSTEM (continued)

Required Selections

Cooling Capacity

Specify nominal cooling capacity of the unit.

Options/Accessories

Field Installed

Condensate Drain Trap

Field installed only.

Available in copper or PVC.

Compressor Crankcase Heater

Protects against refrigerant migration that can occur during low ambient operation.

Drain Pan Overflow Switch

Monitors condensate level in drain pan, shuts down unit if drain becomes clogged.

Low Ambient Kit

Cycles the outdoor fan while allowing compressor operation in the cooling cycle. This intermittent fan operation allows the system to operate without icing the evaporator coil and losing capacity. Designed for use in ambient temperatures no lower than 0°F. A crankcase heater must be installed on the compressor.

CABINET

4 Construction

Heavy-gauge steel panels and full perimeter heavy-gauge galvanized steel base rail provides structural integrity for transportation, handling, and installation.

Base rails have rigging holes. Three sides of the base rail have fork slots.

Raised edges around duct and power entry openings in the bottom of the unit provide additional protection against water entering the building.

Air-Flow Choice

Units are shipped in downflow (vertical) configuration, can be field converted to horizontal air flow configuration without the need of a kit.

5 Power Entry

Electrical lines can be brought through the unit base or through horizontal access knock-outs.

Optional Bottom Power Entry Kit is available.

6 Exterior Panels

Constructed of heavy-gauge, galvanized steel with a two-layer enamel paint finish.

7 Insulation

All panels adjacent to conditioned air are fully insulated with non-hygroscopic fiberglass insulation.

Access Panels

Access panels are provided for the compressor, heating, controls, blower and air filter/economizer section.

Options/Accessories

Factory Installed

Corrosion Protection

A completely flexible immersed coating with an electro-deposited dry film process. (AST ElectroFin E-Coat) Meets Mil Spec MIL-P-53084, ASTM B117 Standard Method Salt Spray Testing.

Indoor Corrosion Protection:

- Coated coil

Outdoor Corrosion Protection:

- Coated coil

Field Installed

Coil/Hail Guards

Constructed of heavy gauge steel, painted to match cabinet, helps protect outdoor coil from damage on all three sides of cabinet.

FEATURES AND BENEFITS

CONTROLS

Unit Control

All control voltage is provided via a 24V (secondary) transformer with inline fuse protection.

Heat/Cool Staging

Capable of up to 1 heat / 2 cool staging with a thermostat.

Night Setback Mode

Saves energy by closing outdoor air dampers and operating supply fan on thermostat demand only.

Smoke Detectors

NOTE - Smoke detectors are not available and must be field provided by installer.

§ BLOWER

A wide selection of supply air blower options are available to meet a variety of air flow requirements.

Motor

Overload protected, equipped with ball bearings. Belt drive motors are offered on all models and are available in several different sizes to maximize air performance.

Supply Air Blower

Forward curved blades, blower wheel is statically and dynamically balanced.

Equipped with ball bearings and adjustable pulley (allows speed change).

Required Selections

Supply Air Blower

Order blower motor horsepower and drive kit number required when base unit is ordered, see Drive Kit Specifications Table.

INDOOR AIR QUALITY

Air Filters

Disposable 2 inch filters furnished as standard.

Options/Accessories

Field Installed

Indoor Air Quality (CO₂) Sensor

Monitors CO₂ levels adjusts economizer dampers as needed for Demand Control Ventilation.

ELECTRICAL

Required Selections

Voltage Choice

Specify when ordering base unit.

Field Installed

Electric Heat

Helix wound nichrome elements, individual element limit controls, wiring harness. See Options / Accessories tables for ordering information.

NOTE - Unit Fuse Block is required and must be ordered separately. See Electrical/Electric Heat tables for ordering information.

SERVICEABILITY

Designed to streamline general maintenance and decrease troubleshooting time.

Marked & Color-Coded Wiring

All electrical wiring is color-coded and marked to identify which components it is connecting.

Electrical Plugs

Positive connection electrical plugs are used to connect common accessories or maintenance parts for easy removal or installation.

Blower Access

Supply air blower parts are located near the access door for easy servicing and adjustment.

Coil Cleaning

Condenser coil allows easy cleaning.

Compressor Compartment

Compressor is located near the perimeter of the unit in the outdoor compartment for easier access.

Hinged service panel in the condenser section allows system operation checks to be done without changing the air flow across the outdoor coils.

OPTIONS / ACCESSORIES

ECONOMIZER/OUTDOOR AIR/EXHAUST OPTIONS

Factory or Field Installed

Economizer

Downflow (Factory Installed)

Downflow or Horizontal

(Field Installed)

Gear-driven action return air and outdoor air dampers, plug-in connections to unit, nylon bearings, neoprene seals, 24-volt, fully-modulating spring return motor, adjustable minimum damper position.

Outdoor Air Hood is furnished.

Economizer includes Barometric Relief Dampers with Exhaust Hood.

Barometric Relief Dampers allow relief of excess air, aluminum blade dampers prevent blow back and outdoor air infiltration during off cycle.

Single Sensible Temperature Control is furnished with the economizer

Outdoor air sensor enables Economizer if the outdoor temperature is less than the setpoint of the control.

Outdoor Air Dampers -

Downflow

Linked mechanical dampers, 0 to 35% (fixed) outdoor air adjustable, installs in unit.

Automatic model features fully modulating spring return damper motor with plug-in connection.

Manual model features a slide damper. Maximum mixed air temperature in cooling mode: 100°F.

Outdoor Air Hood is furnished.

Power Exhaust Fan - Downflow or Horizontal

Installs external to unit for applications with Economizer option. Provides exhaust air pressure relief. Interlocked to run when supply air blower is operating, fan runs when outdoor air dampers are 50% open (adjustable), motor is overload protected.

Fan is 12 in. diameter with 5 fan blades. 1/2 hp motor.

CEILING DIFFUSERS

Ceiling Diffusers

(Flush and Step-Down)

Aluminum grilles, large center grille, insulated diffuser box with flanges, hanging rings furnished, interior transition (even air flow), internally sealed (prevents recirculation), adapts to T-bar ceiling grids or plaster ceilings.

Transitions (Supply and Return)

NOTE - Ceiling Diffuser Transitions are not furnished and must be field fabricated.

ROOF CURB

Roof Curb, Downflow

Full perimeter.

Insulated filler panels are furnished for installation under the outdoor section of the rooftop unit. See dimension drawings.

Nailer strip furnished, mates to unit, US National Roofing Contractors Approved, shipped knocked down. Available in 8, 14, 18, and 24 inch heights.

Clip Curbs use interlocking tabs to fasten together. No tools required.

Standard roof curb corners fasten together with furnished hardware.

OPTIONS / ACCESSORIES

Item		Catalog No.	036	048	060
COOLING SYSTEM					
Condensate Drain Trap	PVC - C1TRAP20AD2	76W26	X	X	X
	Copper - C1TRAP10AD2	76W27	X	X	X
Compressor Crankcase Heater	208/230V-1 or 3ph - Z1CCHT10A-1P	99W61	X	X	
	208/230V-1 or 3 ph - Z1CCHT11A-1P	99W64			X
	460V - 3 ph - Z1CCHT10A-1G	99W62	X	X	
	460V - 3 ph - Z1CCHT11A-1G	99W65			X
	575V - 3 ph - Z1CCHT10A-1J	99W63	X	X	
	575V - 3 ph - Z1CCHT11A-1J	99W66			X
Drain Pan Overflow Switch	Z1SNSR90A1	99W59	X	X	X
Low Ambient Kit	Z1SNSR33A-1	99W67	X	X	X
BLOWER - SUPPLY AIR					
Motors	¹ Belt Drive - 1 hp Standard Efficiency	Factory	O	O	O
	Belt Drive - 1.5 hp Standard Efficiency	Factory	O	O	O
Drive Kits See Blower Data Tables for selection	Kit #Z01 - 678-1035 rpm	Factory	O		
	Kit #Z02 - 803-1226 rpm	Factory		O	
	Kit #Z03 - 906-1383 rpm	Factory			O
	Kit #Z04 - 964-1471 rpm	Factory	O		
	² Kit #Z05 -1098-1490 rpm	Factory		O	
	² Kit #Z06 - 1262-1634 rpm	Factory			O
CABINET					
Coil/Hail Guards	Z1GARD10A-1	97W53	X	X	X
Corrosion Protection		Factory	O	O	O
ELECTRICAL					
Voltage 60 hz	208/230V - 1 phase	Factory	O	O	O
	208/230V - 3 phase	Factory	O	O	O
	460V - 3 phase	Factory	O	O	O
	575V - 3 phase	Factory	O	O	O
Bottom Power Entry Kit	Z1PEKT01A-1	98W08	X	X	X
ELECTRIC HEAT					
5 kW	208/230V-1ph - Z1EH0050AN1P	98W96	X	X	X
	208/230V-3ph - Z1EH0050AN1Y	99W01	X	X	X
	460V-3ph - Z1EH0050AN1G	99W06	X	X	X
	575V-3ph - Z1EH0050AN1J	99W11	X	X	X
7.5 kW	208/230V-1ph - Z1EH0075AN1P	98W97	X	X	X
	208/230V-3ph - Z1EH0075AN1Y	99W02	X	X	X
	460V-3ph - Z1EH0075AN1G	99W07	X	X	X
	575V-3ph - Z1EH0075AN1J	99W12	X	X	X
10 kW	208/230V-1ph - Z1EH0100AN1P	98W98	X	X	X
	208/230V-3ph - Z1EH0100AN1Y	99W03	X	X	X
	460V-3ph - Z1EH0100AN1G	99W08	X	X	X
	575V-3ph - Z1EH0100AN1J	99W13	X	X	X
15 kW	208/230V-1ph - Z1EH0150AN1P	98W99	X	X	X
	208/230V-3ph - Z1EH0150AN1Y	99W04	X	X	X
	460V-3ph - Z1EH0150AN1G	99W09	X	X	X
	575V-3ph - Z1EH0150AN1J	99W14	X	X	X
22.5 kW	208/230V-1ph - Z1EH0225AN1P	99W00		X	X
	208/230V-3ph - Z1EH0225AN1Y	99W05		X	X
	460V-3ph - Z1EH0225AN1G	99W10		X	X
	575V-3ph - Z1EH0225AN1J	99W15		X	X
ELECTRIC HEAT ACCESSORIES					
Unit Fuse Block (required) - See Electrical/Electric Heat Tables for Selection			X	X	X

¹ 1 hp blower motor is not available for 208/230V-1ph applications.

² 1.5 hp motor is required with Z05 and Z06 drive kits.

NOTE - The catalog and model numbers that appear here are for ordering field installed accessories only.

OX - Field Installed or Configure to Order (factory installed)

O - Configure to Order (Factory Installed)

X - Field Installed.

OPTIONS / ACCESSORIES

Item		Catalog No.	036	048	060
ECONOMIZER					
Economizer - With Barometric Relief Dampers and Exhaust Hood (Downflow)	Z1ECON30A-1	98W09	OX	OX	OX
Economizer - With Barometric Relief Dampers and Exhaust Hood (Horizontal)	Z1ECON16A-1	98W68	X	X	X
Economizer Controls					
Single Enthalpy Control	C1SNSR64FF1	53W64	X	X	X
OUTDOOR AIR					
Outdoor Air Dampers - Includes Outdoor Air Hood					
Motorized	Z1DAMP21A-1	95W74	X	X	X
Manual	Z1DAMP11A-1	95W73	X	X	X
POWER EXHAUST FAN					
Standard Static (Downflow)	208/230V-1 or 3ph - Z1PWRE10A-1P	21E01	X	X	X
	460V-3ph - Z1PWRE10A-1G	23E01	X	X	X
Standard Static (Horizontal)	208/230V-1 or 3ph - Z1PWRE15A-1P	24E01	X	X	X
	460V-3ph - Z1PWRE15A-1G	28E01	X	X	X
575V Transformer Kit	575V-3ph - Z1TRFM20A-1J	59E02	X	X	X
NOTE - Order 575V Transformer Kit with 208/230V Power Exhaust Fan for 575V applications.					
INDOOR AIR QUALITY					
Indoor Air Quality (CO₂) Sensors					
Sensor - Wall-mount, off-white plastic cover with LCD display	C0SNSR50AE1L	77N39	X	X	X
Sensor - Wall-mount, black plastic case, no display, rated for plenum mounting	C0SNSR53AE1L	87N54	X	X	X
CO ₂ Sensor Duct Mounting Kit - for downflow applications	C0MISC19AE1	85L43	X	X	X
Aspiration Box - for duct mounting non-plenum rated CO ₂ sensor (77N39)	C0MISC16AE1	90N43	X	X	X
ROOF CURBS - DOWNFLOW					
Clip Curb					
8 in. height	Z1CURB40A-1	95W18	X	X	X
14 in. height	Z1CURB41A-1	95W19	X	X	X
18 in. height	Z1CURB42A-1	95W20	X	X	X
24 in. height	Z1CURB43A-1	95W21	X	X	X
Standard Curb					
14 in. height	Z1CURB10A-1	92W50	X	X	X
CEILING DIFFUSERS					
Step-Down - Order one	RTD9-65-R	27G87	X	X	X
Flush - Order one	FD9-65-R	27G86	X	X	X

NOTE - Ceiling Diffuser Transitions are not furnished and must be field fabricated.

NOTE - The catalog and model numbers that appear here are for ordering field installed accessories only.

OX - Field Installed or Configure to Order (factory installed)

O - Configure to Order (Factory Installed)

X - Field Installed.

SPECIFICATIONS

General Data		Nominal Tonnage	3 Ton	4 Ton	5 Ton
		Model No.	ZCA036S4B	ZCA048S4B	ZCA060S4B
		Efficiency Type	Standard	Standard	Standard
Cooling Performance	Gross Cooling Capacity - Btuh		36,100	47,000	58,900
	¹ Net Cooling Capacity - Btuh		34,600	45,000	57,000
	AHRI Rated Air Flow - cfm		1200	1550	1650
	² Sound Rating Number (SRN) (dBA)		77	80	83
	Total Unit Power - kW		3.0	4.3	5.3
	¹ SEER (Btuh/Watt)		13.00	13.00	13.00
	¹ EER (Btuh/Watt)		11.50	10.60	10.70
Refrigerant	Type		R-410A	R-410A	R-410A
	Charge Furnished		4 lbs. 1 oz.	4 lbs. 6 oz.	5 lbs. 6 oz.
Electric Heat Available - See page 7			5, 7.5, 10, 15 kW	5, 7.5, 10, 15, 22.5 kW	
Compressor Type (one per unit)			Scroll	Scroll	Scroll
Outdoor Coil	Net face area - sq. ft.		12.8	12.8	15.2
	Number of rows		1	1	1
	Fins / inch		23	23	23
Outdoor Coil Fan	Motor HP		(1) 1/6 (PSC)	(1) 1/4 (PSC)	(1) 1/3 (PSC)
	Motor rpm		825	825	1075
	Total motor watts		200	310	360
	Diameter - in.		(1) 22	(1) 22	(1) 22
	Number of blades		4	4	3
	Total air volume - cfm		2700	3300	3800
	Indoor Coil	Net face area - sq. ft.		8.4	8.4
Tube diameter - in.			3/8	3/8	3/8
Number of rows			2	2	3
Fins per inch			14	14	14
Drain Connection (no. and size) - in.			(1) 1 NPT	(1) 1 NPT	(1) 1 NPT
Expansion device type			Fixed Orifice	Fixed Orifice	Fixed Orifice
³ Indoor Blower & Drive Selection		Nominal Motor HP		⁴ 1 hp, 1.5 hp	⁴ 1 hp, 1.5 hp
	Maximum Usable Motor HP		1.15 hp, 1.7 hp	1.15 hp, 1.7 hp	1.15 hp, 1.7 hp
	Available Drive Kits		Kit #Z01 678-1035 rpm	Kit #Z02 803-1226 rpm	Kit #Z03 906-1383 rpm
			Kit #Z04 964-1471 rpm	⁵ Kit #Z05 1098-1490 rpm	⁵ Kit #Z06 1262-1634 rpm
Wheel nominal diameter x width - in.			10 x 10	10 x 10	10 x 10
Filters	Type		Disposable		
	Number and size - in.		(4) 14 x 20 x 2		
Electrical Characteristics - 60 Hz			208/230V 1 phase	208/230V, 1 phase	208/230V, 1 phase
			208/230V, 460V & 575V 3 phase	208/230V 460V & 575V 3 phase	208/230V 460V & 575V 3 phase

NOTE - Net capacity includes evaporator blower motor heat deduction. Gross capacity does not include evaporator blower motor heat deduction.

¹ AHRI Certified to AHRI Standard 210/240: 95°F outdoor air temperature and 80°F db/67°F wb entering evaporator air; minimum external duct static pressure.

² Sound Rating Number (SRN) rated in accordance with test conditions included in ANSI/AHRI Standard 270-2008.

³ Using total air volume and system static pressure requirements determine from blower performance tables rpm and motor hp required. Maximum usable hp of motors furnished are shown. In Canada, nominal motor hp is also maximum usable motor hp output. If motors of comparable hp are used, be sure to keep within the service factor limitations outlined on the motor nameplate.

⁴ 1 hp blower motor is not available for 208/230V-1ph applications.

⁵ 1.5 hp motor is required with Z05 and Z06 drive kits.

RATINGS

NOTE – For Temperatures and Capacities not shown in tables, see bulletin – Cooling Unit Rating Table Correction Factor Data in Miscellaneous Engineering Data section.

3 TON STANDARD EFFICIENCY ZCA036S4

Entering Wet Bulb Temperature	Total Air Volume	Outdoor Air Temperature Entering Outdoor Coil																			
		85°F					95°F					105°F					115°F				
		Total Cool Cap.	Comp. Motor Input	Sensible To Total Ratio (S/T) Dry Bulb			Total Cool Cap.	Comp. Motor Input	Sensible To Total Ratio (S/T) Dry Bulb			Total Cool Cap.	Comp. Motor Input	Sensible To Total Ratio (S/T) Dry Bulb			Total Cool Cap.	Comp. Motor Input	Sensible To Total Ratio (S/T) Dry Bulb		
				75°F	80°F	85°F			75°F	80°F	85°F			75°F	80°F	85°F			75°F	80°F	85°F
cfm	kBtuh	kW				kBtuh	kW				kBtuh	kW				kBtuh	kW				
63°F	960	33.5	2.11	.69	.84	.97	31.0	2.40	.69	.84	.99	27.8	2.71	.69	.86	1.00	23.6	3.04	.70	.90	1.00
	1200	36.0	2.11	.75	.91	1.00	33.4	2.41	.75	.92	1.00	30.0	2.73	.75	.95	1.00	25.5	3.05	.78	.99	1.00
	1440	38.0	2.12	.79	.97	1.00	35.2	2.42	.80	.98	1.00	31.8	2.74	.81	1.00	1.00	27.3	3.06	.85	1.00	1.00
67°F	960	36.0	2.11	.53	.67	.81	33.4	2.41	.52	.67	.81	30.1	2.73	.50	.67	.83	25.6	3.05	.49	.68	.87
	1200	38.6	2.12	.57	.73	.87	35.8	2.42	.56	.73	.89	32.2	2.74	.55	.74	.91	27.3	3.06	.55	.77	.96
	1440	40.5	2.13	.60	.77	.94	37.4	2.43	.60	.78	.95	33.6	2.74	.59	.80	.98	28.7	3.07	.60	.84	1.00
71°F	960	38.4	2.12	.38	.53	.65	35.6	2.42	.36	.52	.65	32.2	2.74	.34	.50	.65	27.5	3.06	.31	.49	.67
	1200	41.1	2.13	.41	.57	.71	38.1	2.43	.40	.56	.71	34.4	2.75	.37	.55	.72	29.4	3.07	.35	.55	.75
	1440	43.0	2.14	.43	.60	.76	39.9	2.44	.42	.59	.76	36.0	2.76	.40	.59	.78	30.6	3.08	.35	.60	.82

4 TON STANDARD EFFICIENCY ZCA048S4

Entering Wet Bulb Temperature	Total Air Volume	Outdoor Air Temperature Entering Outdoor Coil																			
		85°F					95°F					105°F					115°F				
		Total Cool Cap.	Comp. Motor Input	Sensible To Total Ratio (S/T) Dry Bulb			Total Cool Cap.	Comp. Motor Input	Sensible To Total Ratio (S/T) Dry Bulb			Total Cool Cap.	Comp. Motor Input	Sensible To Total Ratio (S/T) Dry Bulb			Total Cool Cap.	Comp. Motor Input	Sensible To Total Ratio (S/T) Dry Bulb		
				75°F	80°F	85°F			75°F	80°F	85°F			75°F	80°F	85°F			75°F	80°F	85°F
cfm	kBtuh	kW				kBtuh	kW				kBtuh	kW				kBtuh	kW				
63°F	1280	46.0	3.09	.71	.85	.97	42.9	3.48	.71	.86	.99	39.5	3.93	.71	.87	1.00	34.3	4.48	.73	.91	1.00
	1600	49.1	3.09	.76	.91	1.00	45.7	3.48	.77	.93	1.00	41.9	3.94	.78	.95	1.00	36.3	4.50	.81	.99	1.00
	1920	51.5	3.09	.81	.97	1.00	47.8	3.49	.82	.99	1.00	43.9	3.96	.83	1.00	1.00	38.4	4.51	.87	1.00	1.00
67°F	1280	49.2	3.09	.55	.69	.81	45.9	3.49	.54	.69	.83	42.3	3.94	.53	.69	.84	36.9	4.50	.53	.71	.88
	1600	52.5	3.10	.58	.74	.88	48.9	3.49	.58	.75	.89	44.9	3.96	.58	.76	.92	38.9	4.52	.58	.79	.97
	1920	55.0	3.10	.62	.79	.94	51.1	3.50	.61	.80	.96	46.8	3.98	.62	.81	.99	40.4	4.53	.63	.86	1.00
71°F	1280	52.3	3.10	.41	.54	.67	48.8	3.49	.40	.54	.67	44.9	3.96	.38	.53	.68	39.2	4.52	.36	.53	.70
	1600	55.8	3.11	.42	.58	.72	51.9	3.50	.42	.58	.73	47.6	3.97	.40	.57	.74	41.4	4.54	.38	.58	.77
	1920	58.3	3.11	.44	.61	.77	54.2	3.51	.43	.61	.78	49.6	3.99	.42	.62	.80	42.9	4.55	.41	.64	.84

5 TON STANDARD EFFICIENCY ZCA060S4

Entering Wet Bulb Temperature	Total Air Volume	Outdoor Air Temperature Entering Outdoor Coil																			
		85°F					95°F					105°F					115°F				
		Total Cool Cap.	Comp. Motor Input	Sensible To Total Ratio (S/T) Dry Bulb			Total Cool Cap.	Comp. Motor Input	Sensible To Total Ratio (S/T) Dry Bulb			Total Cool Cap.	Comp. Motor Input	Sensible To Total Ratio (S/T) Dry Bulb			Total Cool Cap.	Comp. Motor Input	Sensible To Total Ratio (S/T) Dry Bulb		
				75°F	80°F	85°F			75°F	80°F	85°F			75°F	80°F	85°F			75°F	80°F	85°F
cfm	kBtuh	kW				kBtuh	kW				kBtuh	kW				kBtuh	kW				
63°F	1600	56.5	3.67	.73	.87	1.00	52.4	4.13	.74	.90	1.00	48.0	4.65	.76	.93	1.00	43.0	5.26	.78	.97	1.00
	2000	59.4	3.70	.78	.95	1.00	55.1	4.16	.80	.98	1.00	50.5	4.69	.83	1.00	1.00	45.9	5.31	.86	1.00	1.00
	2400	61.7	3.72	.84	1.00	1.00	57.7	4.19	.86	1.00	1.00	53.4	4.72	.89	1.00	1.00	48.5	5.36	.94	1.00	1.00
67°F	1600	60.3	3.71	.57	.70	.84	56.0	4.16	.57	.72	.86	51.4	4.70	.57	.73	.89	46.2	5.32	.58	.76	.94
	2000	63.3	3.73	.60	.76	.92	58.8	4.20	.61	.78	.95	53.8	4.74	.62	.81	.99	48.4	5.36	.63	.84	1.00
	2400	65.6	3.76	.64	.82	.99	60.8	4.22	.65	.84	1.00	55.7	4.76	.66	.87	1.00	49.7	5.38	.68	.92	1.00
71°F	1600	64.0	3.74	.42	.55	.68	59.5	4.20	.42	.56	.70	54.7	4.75	.41	.56	.71	49.3	5.37	.40	.57	.74
	2000	67.2	3.77	.44	.59	.74	62.4	4.24	.44	.60	.76	57.3	4.79	.43	.61	.78	51.7	5.42	.43	.63	.82
	2400	69.6	3.80	.45	.63	.80	64.7	4.27	.45	.64	.82	59.3	4.82	.45	.66	.85	53.2	5.45	.45	.68	.90

BLOWER DATA - BELT DRIVE - ZCA036

BLOWER TABLE INCLUDES RESISTANCE FOR BASE UNIT ONLY WITH DRY INDOOR COIL AND AIR FILTERS IN PLACE.

FOR ALL UNITS ADD:

1 - Any factory installed options air resistance (heat section, economizer, wet coil, etc.).

2 - Any field installed accessories air resistance (duct resistance, diffuser, etc.).

See page 14 for blower motors and drives and wet coil and options/accessory air resistance data.

DOWNFLOW

Air Volume cfm	External Static - in. w.g.																
	0.10		0.20		0.30		0.40		0.50		0.60		0.70		0.80		
	RPM	BHP	RPM	BHP	RPM	BHP	RPM	BHP	RPM	BHP	RPM	BHP	RPM	BHP	RPM	BHP	
	Field Furnished				Kit Z01												
900	555	0.16	621	0.17	691	0.19	763	0.20	832	0.22	897	0.24	956	0.26	1010	0.29	
1000	577	0.18	644	0.19	715	0.21	786	0.23	855	0.24	919	0.27	976	0.29	1028	0.32	
1100	601	0.20	670	0.22	741	0.23	812	0.25	879	0.28	941	0.30	996	0.33	1047	0.37	
1200	629	0.22	698	0.24	770	0.26	840	0.28	905	0.31	965	0.34	1018	0.38	1066	0.41	
1300	659	0.25	729	0.27	800	0.30	869	0.32	932	0.35	989	0.39	1040	0.43	1087	0.47	
1400	692	0.28	763	0.31	833	0.34	899	0.37	960	0.40	1014	0.44	1063	0.48	1108	0.52	
1500	728	0.32	798	0.35	866	0.38	930	0.41	987	0.45	1039	0.50	1086	0.54	1130	0.58	

Air Volume cfm	External Static - in. w.g.															
	0.90		1.00		1.10		1.20		1.30		1.40		1.50		1.60	
	RPM	BHP	RPM	BHP	RPM	BHP	RPM	BHP	RPM	BHP	RPM	BHP	RPM	BHP	RPM	BHP
	Kit Z04															
900	1060	0.31	1108	0.34	1154	0.37	1197	0.40	1239	0.44	1279	0.47	1319	0.51	1359	0.55
1000	1077	0.35	1123	0.38	1168	0.42	1211	0.45	1252	0.49	1291	0.52	1330	0.56	1370	0.60
1100	1094	0.40	1139	0.43	1183	0.46	1225	0.50	1266	0.54	1305	0.58	1343	0.62	1382	0.66
1200	1112	0.45	1156	0.48	1199	0.52	1241	0.55	1281	0.59	1319	0.64	1357	0.68	1394	0.72
1300	1131	0.50	1174	0.54	1216	0.57	1257	0.61	1296	0.66	1334	0.70	1371	0.74	1408	0.78
1400	1151	0.56	1193	0.60	1234	0.64	1274	0.68	1313	0.72	1351	0.77	1387	0.81	1423	0.86
1500	1172	0.62	1213	0.66	1253	0.71	1293	0.75	1331	0.79	1368	0.84	1404	0.89	1440	0.93

HORIZONTAL

Air Volume cfm	External Static - in. w.g.																	
	0.10		0.20		0.30		0.40		0.50		0.60		0.70		0.80			
	RPM	BHP	RPM	BHP	RPM	BHP	RPM	BHP	RPM	BHP	RPM	BHP	RPM	BHP	RPM	BHP		
	Field Furnished				Kit Z01												Kit Z04	
900	572	0.14	641	0.16	712	0.19	785	0.22	860	0.24	931	0.27	991	0.29	1039	0.32		
1000	602	0.16	671	0.19	742	0.22	815	0.24	887	0.27	954	0.30	1010	0.33	1055	0.36		
1100	636	0.19	706	0.22	776	0.25	847	0.28	916	0.31	977	0.34	1028	0.37	1070	0.41		
1200	674	0.23	744	0.26	813	0.29	881	0.32	944	0.35	999	0.38	1045	0.42	1087	0.45		
1300	716	0.26	784	0.29	851	0.33	914	0.36	971	0.40	1020	0.43	1064	0.47	1106	0.50		
1400	759	0.30	824	0.34	888	0.37	946	0.41	998	0.45	1043	0.49	1086	0.52	1129	0.55		
1500	803	0.35	865	0.39	925	0.43	979	0.47	1027	0.52	1070	0.55	1113	0.58	1156	0.61		

Air Volume cfm	External Static - in. w.g.															
	0.90		1.00		1.10		1.20		1.30		1.40		1.50		1.60	
	RPM	BHP	RPM	BHP	RPM	BHP	RPM	BHP	RPM	BHP	RPM	BHP	RPM	BHP	RPM	BHP
	Kit Z04															
900	1085	0.35	1135	0.38	1183	0.40	1227	0.42	1268	0.45	1305	0.49	1342	0.53	1379	0.57
1000	1099	0.39	1148	0.42	1195	0.44	1239	0.47	1279	0.50	1316	0.54	1352	0.58	1389	0.62
1100	1114	0.44	1163	0.46	1210	0.49	1253	0.52	1292	0.55	1329	0.59	1364	0.64	1401	0.68
1200	1131	0.48	1180	0.51	1226	0.54	1269	0.57	1308	0.61	1343	0.66	1378	0.70	1414	0.75
1300	1151	0.53	1199	0.56	1245	0.59	1287	0.63	1324	0.68	1359	0.72	1394	0.77	1429	0.82
1400	1175	0.58	1222	0.62	1266	0.66	1306	0.70	1342	0.75	1376	0.80	1410	0.85	1446	0.89
1500	1201	0.65	1246	0.68	1289	0.73	1327	0.78	1362	0.83	1395	0.88	1429	0.93	1464	0.98

BLOWER DATA - BELT DRIVE - ZCA048

BLOWER TABLE INCLUDES RESISTANCE FOR BASE UNIT ONLY WITH DRY INDOOR COIL AND AIR FILTERS IN PLACE.

FOR ALL UNITS ADD:

1 - Any factory installed options air resistance (heat section, economizer, wet coil, etc.).

2 - Any field installed accessories air resistance (duct resistance, diffuser, etc.).

See page 14 for blower motors and drives and wet coil and options/accessory air resistance data.

DOWNFLOW

Air Volume cfm	External Static - in. w.g.															
	0.10		0.20		0.30		0.40		0.50		0.60		0.70		0.80	
	RPM	BHP	RPM	BHP	RPM	BHP	RPM	BHP	RPM	BHP	RPM	BHP	RPM	BHP	RPM	BHP
	Field Furnished						Kit Z02									
1200	629	0.22	698	0.24	770	0.26	840	0.28	905	0.31	965	0.34	1018	0.38	1066	0.41
1300	659	0.25	729	0.27	800	0.30	869	0.32	932	0.35	989	0.39	1040	0.43	1087	0.47
1400	692	0.28	763	0.31	833	0.34	899	0.37	960	0.40	1014	0.44	1063	0.48	1108	0.52
1500	728	0.32	798	0.35	866	0.38	930	0.41	987	0.45	1039	0.50	1086	0.54	1130	0.58
1600	766	0.37	835	0.40	900	0.43	960	0.47	1015	0.51	1065	0.55	1110	0.60	1152	0.65
1700	806	0.42	871	0.45	934	0.48	991	0.52	1043	0.56	1091	0.61	1134	0.66	1176	0.71
1800	845	0.47	908	0.50	967	0.54	1021	0.58	1071	0.63	1117	0.68	1159	0.73	1200	0.78
1900	884	0.53	944	0.56	1000	0.60	1051	0.64	1099	0.69	1143	0.75	1185	0.80	1225	0.86
2000	923	0.59	979	0.63	1032	0.67	1082	0.72	1128	0.77	1171	0.83	1211	0.89	1251	0.95

Air Volume cfm	External Static - in. w.g.															
	0.90		1.00		1.10		1.20		1.30		1.40		1.50		1.60	
	RPM	BHP	RPM	BHP	RPM	BHP	RPM	BHP	RPM	BHP	RPM	BHP	RPM	BHP	RPM	BHP
	Kit Z02						Kit Z05									
1200	1112	0.45	1156	0.48	1199	0.52	1241	0.55	1281	0.59	1319	0.64	1357	0.68	1394	0.72
1300	1131	0.50	1174	0.54	1216	0.57	1257	0.61	1296	0.66	1334	0.70	1371	0.74	1408	0.78
1400	1151	0.56	1193	0.60	1234	0.64	1274	0.68	1313	0.72	1351	0.77	1387	0.81	1423	0.86
1500	1172	0.62	1213	0.66	1253	0.71	1293	0.75	1331	0.79	1368	0.84	1404	0.89	1440	0.93
1600	1193	0.69	1234	0.73	1273	0.78	1313	0.82	1350	0.87	1387	0.92	1422	0.97	1457	1.01
1700	1216	0.76	1255	0.81	1295	0.86	1333	0.90	1370	0.95	1406	1.00	1441	1.05	1475	1.10
1800	1239	0.84	1279	0.89	1317	0.94	1355	0.99	1391	1.04	1426	1.09	1461	1.14	1494	1.19
1900	1264	0.92	1303	0.98	1341	1.03	1378	1.08	1413	1.14	1448	1.19	1481	1.24	1514	1.29
2000	1290	1.01	1328	1.07	1366	1.13	1402	1.19	1436	1.24	1470	1.29	1503	1.35	1535	1.40

HORIZONTAL

Air Volume cfm	External Static - in. w.g.															
	0.10		0.20		0.30		0.40		0.50		0.60		0.70		0.80	
	RPM	BHP	RPM	BHP	RPM	BHP	RPM	BHP	RPM	BHP	RPM	BHP	RPM	BHP	RPM	BHP
	Field Furnished						Kit Z02									
1200	674	0.23	744	0.26	813	0.29	881	0.32	944	0.35	999	0.38	1045	0.42	1087	0.45
1300	716	0.26	784	0.29	851	0.33	914	0.36	971	0.40	1020	0.43	1064	0.47	1106	0.50
1400	759	0.30	824	0.34	888	0.37	946	0.41	998	0.45	1043	0.49	1086	0.52	1129	0.55
1500	803	0.35	865	0.39	925	0.43	979	0.47	1027	0.52	1070	0.55	1113	0.58	1156	0.61
1600	847	0.40	905	0.45	961	0.50	1013	0.54	1058	0.58	1100	0.62	1142	0.65	1185	0.68
1700	890	0.47	944	0.52	997	0.57	1047	0.62	1091	0.66	1132	0.69	1173	0.72	1216	0.76
1800	930	0.54	982	0.60	1033	0.65	1081	0.70	1124	0.74	1165	0.77	1206	0.80	1248	0.84
1900	970	0.62	1020	0.68	1069	0.73	1116	0.78	1158	0.81	1199	0.85	1239	0.89	1280	0.93
2000	1009	0.71	1058	0.76	1106	0.81	1151	0.86	1193	0.9	1233	0.94	1273	0.98	1312	1.04

Air Volume cfm	External Static - in. w.g.															
	0.90		1.00		1.10		1.20		1.30		1.40		1.50		1.60	
	RPM	BHP	RPM	BHP	RPM	BHP	RPM	BHP	RPM	BHP	RPM	BHP	RPM	BHP	RPM	BHP
	Kit Z02						Kit Z05									
1200	1131	0.48	1180	0.51	1226	0.54	1269	0.57	1308	0.61	1343	0.66	1378	0.70	1414	0.75
1300	1151	0.53	1199	0.56	1245	0.59	1287	0.63	1324	0.68	1359	0.72	1394	0.77	1429	0.82
1400	1175	0.58	1222	0.62	1266	0.66	1306	0.70	1342	0.75	1376	0.80	1410	0.85	1446	0.89
1500	1201	0.65	1246	0.68	1289	0.73	1327	0.78	1362	0.83	1395	0.88	1429	0.93	1464	0.98
1600	1229	0.72	1273	0.76	1313	0.81	1350	0.86	1384	0.92	1416	0.97	1450	1.02	1485	1.07
1700	1258	0.80	1300	0.85	1338	0.90	1374	0.96	1407	1.02	1440	1.07	1473	1.12	1508	1.17
1800	1289	0.89	1328	0.94	1365	1.00	1399	1.06	1432	1.13	1465	1.18	1498	1.23	1532	1.28
1900	1319	0.99	1357	1.05	1392	1.11	1426	1.18	1459	1.24	1491	1.30	1524	1.35	1558	1.39
2000	1350	1.10	1387	1.16	1421	1.23	1454	1.30	1486	1.36	1518	1.42	1551	1.47	1584	1.51

BLOWER DATA - BELT DRIVE - ZCA060

BLOWER TABLE INCLUDES RESISTANCE FOR BASE UNIT ONLY WITH DRY INDOOR COIL AND AIR FILTERS IN PLACE.

FOR ALL UNITS ADD:

1 - Any factory installed options air resistance (heat section, economizer, wet coil, etc.).

2 - Any field installed accessories air resistance (duct resistance, diffuser, etc.).

See page 14 for blower motors and drives and wet coil and options/accessory air resistance data.

DOWNFLOW

Air Volume cfm	External Static - in. w.g.															
	0.10		0.20		0.30		0.40		0.50		0.60		0.70		0.80	
	RPM	BHP	RPM	BHP	RPM	BHP	RPM	BHP	RPM	BHP	RPM	BHP	RPM	BHP	RPM	BHP
	Field Furnished				Kit Z03											
1600	787	0.38	854	0.41	918	0.44	976	0.48	1030	0.52	1078	0.56	1123	0.61	1164	0.66
1700	827	0.43	892	0.46	952	0.49	1007	0.53	1058	0.58	1105	0.63	1148	0.68	1189	0.73
1800	868	0.48	929	0.52	986	0.55	1038	0.59	1087	0.64	1132	0.69	1174	0.75	1214	0.80
1900	907	0.54	966	0.58	1019	0.62	1069	0.66	1116	0.71	1160	0.77	1200	0.82	1240	0.88
2000	946	0.60	1001	0.65	1053	0.69	1101	0.74	1146	0.79	1188	0.85	1228	0.91	1267	0.98
2100	984	0.68	1037	0.72	1086	0.77	1132	0.83	1176	0.89	1217	0.95	1256	1.01	1295	1.08
2200	1021	0.75	1072	0.81	1120	0.86	1165	0.92	1207	0.99	1247	1.05	1286	1.12	1324	1.19
2300	1059	0.84	1108	0.90	1154	0.96	1197	1.03	1239	1.10	1278	1.17	1316	1.24	1354	1.32
2400	1097	0.95	1144	1.01	1188	1.08	1231	1.15	1271	1.22	1310	1.30	1348	1.38	1385	1.45

Air Volume cfm	External Static - in. w.g.															
	0.90		1.00		1.10		1.20		1.30		1.40		1.50		1.60	
	RPM	BHP	RPM	BHP	RPM	BHP	RPM	BHP	RPM	BHP	RPM	BHP	RPM	BHP	RPM	BHP
	Kit Z03								Kit Z06							
1600	1205	0.70	1245	0.75	1284	0.79	1323	0.84	1361	0.88	1397	0.93	1432	0.98	1467	1.03
1700	1228	0.78	1268	0.82	1307	0.87	1345	0.92	1382	0.97	1417	1.02	1452	1.07	1486	1.11
1800	1253	0.85	1292	0.91	1331	0.96	1368	1.01	1404	1.06	1439	1.11	1473	1.16	1506	1.21
1900	1279	0.94	1317	1.00	1355	1.05	1392	1.10	1427	1.16	1461	1.21	1494	1.26	1527	1.31
2000	1305	1.04	1343	1.10	1380	1.15	1416	1.21	1450	1.26	1484	1.32	1516	1.37	1549	1.42
2100	1333	1.14	1370	1.21	1407	1.26	1442	1.32	1475	1.38	1508	1.43	1540	1.48	1572	1.53
2200	1361	1.26	1398	1.32	1434	1.38	1468	1.44	1501	1.50	1533	1.55	1564	1.61	1596	1.66
2300	1391	1.39	1427	1.45	1462	1.51	1495	1.57	1527	1.63	1559	1.68	1590	1.73	1622	1.78
2400	1421	1.52	1456	1.59	1490	1.65	1523	1.71	1555	1.76	1586	1.82	1617	1.87	1649	1.92

HORIZONTAL

Air Volume cfm	External Static - in. w.g.															
	0.10		0.20		0.30		0.40		0.50		0.60		0.70		0.80	
	RPM	BHP	RPM	BHP	RPM	BHP	RPM	BHP	RPM	BHP	RPM	BHP	RPM	BHP	RPM	BHP
	Field Furn.				Kit Z03											
1600	864	0.42	921	0.46	976	0.51	1027	0.56	1072	0.60	1113	0.63	1155	0.66	1198	0.69
1700	907	0.48	961	0.53	1013	0.58	1061	0.63	1105	0.67	1146	0.70	1187	0.73	1230	0.77
1800	948	0.56	999	0.61	1049	0.66	1096	0.71	1139	0.75	1180	0.78	1221	0.82	1262	0.86
1900	987	0.64	1037	0.69	1086	0.74	1132	0.79	1174	0.83	1214	0.86	1255	0.90	1295	0.95
2000	1028	0.73	1076	0.78	1123	0.83	1168	0.87	1210	0.91	1250	0.96	1289	1.00	1328	1.06
2100	1071	0.81	1117	0.86	1163	0.91	1206	0.96	1247	1.01	1286	1.06	1324	1.12	1362	1.18
2200	1116	0.91	1160	0.96	1204	1.01	1245	1.07	1285	1.12	1323	1.18	1360	1.25	1396	1.31
2300	1161	1.02	1204	1.07	1245	1.13	1285	1.19	1323	1.25	1360	1.32	1396	1.38	1432	1.45
2400	1207	1.14	1248	1.20	1288	1.26	1326	1.32	1362	1.39	1398	1.46	1433	1.53	1468	1.60

Air Volume cfm	External Static - in. w.g.															
	0.90		1.00		1.10		1.20		1.30		1.40		1.50		1.60	
	RPM	BHP	RPM	BHP	RPM	BHP	RPM	BHP	RPM	BHP	RPM	BHP	RPM	BHP	RPM	BHP
	Kit Z03								Kit Z06							
1600	1242	0.73	1284	0.77	1324	0.82	1360	0.88	1394	0.93	1426	0.99	1460	1.04	1495	1.08
1700	1272	0.81	1312	0.86	1350	0.92	1385	0.98	1418	1.04	1451	1.09	1485	1.14	1519	1.19
1800	1302	0.90	1341	0.96	1377	1.02	1411	1.08	1444	1.15	1477	1.20	1510	1.25	1544	1.30
1900	1334	1.01	1371	1.07	1406	1.13	1439	1.20	1471	1.26	1504	1.32	1537	1.37	1571	1.41
2000	1365	1.12	1401	1.19	1435	1.25	1468	1.32	1500	1.38	1532	1.44	1565	1.49	1598	1.53
2100	1398	1.25	1433	1.31	1466	1.38	1497	1.45	1529	1.51	1561	1.56	1594	1.61	1626	1.65
2200	1431	1.38	1465	1.45	1497	1.52	1528	1.58	1560	1.64	1591	1.69	1623	1.73	1656	1.77
2300	1466	1.52	1498	1.59	1529	1.66	1560	1.72	1591	1.77	1623	1.82	1654	1.86	1686	1.90
2400	1500	1.67	1532	1.74	1563	1.80	1593	1.86	1624	1.91	1655	1.96	1686	2.00	1718	2.04

BLOWER DATA

DRIVE KIT SPECIFICATIONS

Model No.	Blower Motor Choice (HP)				Drive Kit No.	RPM Range
	Nominal	Maximum	Nominal	Maximum		
036	1	1.15	1.5	1.7	Z01	678 - 1035
					Z04	964 - 1471
048	1	1.15	1.5	1.7	Z02	803 - 1226
					¹ Z05	1098 - 1490
060	1	1.15	1.5	1.7	Z03	906 - 1383
					¹ Z06	1262 - 1634

NOTE - Using total air volume and system static pressure requirements determine from blower performance tables rpm and motor hp required. Maximum usable hp of motors furnished are shown. In Canada, nominal motor hp is also maximum usable motor hp. If motors of comparable hp are used, be sure to keep within the service factor limitations outlined on the motor nameplate.

¹ 1.5 hp motor is required with Z05 and Z06 drive kits.

POWER EXHAUST FAN PERFORMANCE

Return Air System Static Pressure - in. w.g.	Air Volume Exhausted cfm
0.00	1865
0.05	1785
0.10	1710
0.15	1630
0.20	1545
0.25	1450
0.30	1350
0.35	1240

OPTIONS / ACCESSORIES AIR RESISTANCE - in. w.g.

Air Volume cfm	Wet Indoor Coil		Electric Heat	Economizer	
	036-048	060		Downflow	Horizontal
900	0.01	---	0.02	0.04	0.05
1000	0.01	---	0.04	0.04	0.05
1100	0.02	---	0.05	0.04	0.06
1200	0.02	---	0.06	0.05	0.06
1300	0.02	---	0.08	0.05	0.07
1400	0.03	---	0.09	0.06	0.07
1500	0.03	---	0.10	0.07	0.08
1600	0.03	0.04	0.12	0.08	0.09
1700	0.04	0.05	0.13	0.08	0.10
1800	0.04	0.05	0.15	0.09	0.11
1900	0.04	0.06	0.16	0.10	0.12
2000	0.05	0.06	0.17	0.12	0.13
2100	---	0.07	0.19	0.13	0.14
2200	---	0.08	0.20	0.14	0.15
2300	---	0.08	0.21	0.15	0.17
2400	---	0.09	0.23	0.17	0.18

CEILING DIFFUSERS AIR RESISTANCE (in. w.g.)

Air Volume cfm	RTD9-65 Step-Down Diffuser			FD9-65 Flush Diffuser
	2 Ends Open	1 Side & 2 Ends Open	All Ends & Sides Open	
800	0.15	0.13	0.11	0.11
1000	0.19	0.16	0.14	0.14
1200	0.25	0.20	0.17	0.17
1400	0.33	0.26	0.20	0.20
1600	0.43	0.32	0.20	0.24
1800	0.56	0.40	0.30	0.30
2000	0.73	0.50	0.36	0.36
2200	0.95	0.63	0.44	0.44

CEILING DIFFUSER AIR THROW DATA

Air Volume - cfm	¹ Effective Throw - ft.	
	Model No.	RTD9-65
800	10 - 17	14 - 18
1000	10 - 17	15 - 20
1200	11 - 18	16 - 22
1400	12 - 19	17 - 24
1600	12 - 20	18 - 25
1800	13 - 21	20 - 28
2000	14 - 23	21 - 29
2200	16 - 25	22 - 30

¹ Effective throw based on terminal velocities of 75 ft. per minute.

ELECTRICAL DATA

ZCA036S4

¹ Voltage - 60hz		208/230V - 1 Ph	208/230V - 3 Ph		460V - 3 Ph		575V - 3 Ph	
Compressor	Rated Load Amps	15.3	8.7		4		3.6	
	Locked Rotor Amps	70	70		31		27	
Outdoor Fan Motor	Full Load Amps	1	1		0.6		0.45	
Power Exhaust (1) 0.5 HP	Full Load Amps	1.5	1.5		0.6		0.6	
Indoor Blower Motor	Horsepower	1.5	1	1.5	1	1.5	1	1.5
	Full Load Amps	11	4.6	6.6	2.1	3	1.7	2.4
² Maximum Overcurrent Protection	Unit Only	45	25	25	15	15	15	15
	With (1) 0.5 HP Power Exhaust	45	25	25	15	15	15	15
³ Minimum Circuit Ampacity	Unit Only	32	17	19	8	9	7	8
	With (1) 0.5 HP Power Exhaust	33	18	20	9	10	8	8

ELECTRIC HEAT DATA

Electric Heat Voltage			208V	240V	208V	240V	208V	240V	480V	480V	600V	600V
² Maximum Overcurrent Protection	Unit+ Electric Heat	5 kW	45	45	25	25	25	25	15	15	15	15
		7.5 kW	50	60	30	30	30	35	15	20	15	15
		10 kW	60	70	35	40	35	40	20	20	15	20
		15 kW	90	100	45	60	50	60	30	30	25	25
³ Minimum Circuit Ampacity	Unit+ Electric Heat	5 kW	37	40	19	21	22	24	11	12	9	10
		7.5 kW	48	53	26	29	28	31	14	16	12	13
		10 kW	59	66	32	36	35	39	18	19	15	16
		15 kW	82	92	45	51	48	54	26	27	21	22
² Maximum Overcurrent Protection	Unit+ Electric Heat and (1) 0.5 HP Power Exhaust	5 kW	45	45	25	25	25	30	15	15	15	15
		7.5 kW	50	60	30	35	30	35	15	20	15	15
		10 kW	70	70	35	40	40	45	20	20	15	20
		15 kW	90	100	50	60	50	60	30	30	25	25
³ Minimum Circuit Ampacity	Unit+ Electric Heat and (1) 0.5 HP Power Exhaust	5 kW	39	42	21	23	24	26	11	13	9	10
		7.5 kW	50	55	28	31	30	33	15	16	12	13
		10 kW	61	68	34	38	37	41	19	20	15	16
		15 kW	84	94	47	53	50	56	26	28	21	22

ELECTRIC HEAT ACCESSORIES

Unit Fuse Block	Unit Only	10A26	10A27	10A27	10A29	10A29	10A29	10A29
	Unit + Power Exhaust	10A26	10A27	10A27	10A29	10A29	10A29	10A29

NOTE - All units have a minimum Short Circuit Current Rating (SCCR) of 5000 amps.

¹ Extremes of operating range are plus and minus 10% of line voltage.

² HACR type breaker or fuse.

³ Refer to National or Canadian Electrical Code manual to determine wire, fuse and disconnect size requirements.

ELECTRICAL DATA

4 TON

ZCA048S4

¹ Voltage - 60hz		208/230V - 1 Ph	208/230V - 3 Ph		460V - 3 Ph		575V - 3 Ph	
Compressor	Rated Load Amps	20	11		5.5		4.7	
	Locked Rotor Amps	99	86		37		34	
Outdoor Fan Motor	Full Load Amps	1.7	1.7		0.9		0.7	
Power Exhaust (1) 0.5 HP	Full Load Amps	1.5	1.5		0.6		0.6	
Indoor Blower Motor	Horsepower	1.5	1	1.5	1	1.5	1	1.5
	Full Load Amps	11	4.6	6.6	2.1	3	1.7	2.4
² Maximum Overcurrent Protection	Unit Only	50	30	30	15	15	15	15
	With (1) 0.5 HP Power Exhaust	50	30	30	15	15	15	15
³ Minimum Circuit Ampacity	Unit Only	38	21	23	10	11	9	9
	With (1) 0.5 HP Power Exhaust	40	22	24	11	12	9	10

ELECTRIC HEAT DATA

Electric Heat Voltage			208V	240V	208V	240V	208V	240V	480V	480V	600V	600V
² Maximum Overcurrent Protection	Unit+ Electric Heat	5 kW	50	50	30	30	30	30	15	15	15	15
		7.5 kW	50	60	30	30	30	35	15	20	15	15
		10 kW	60	70	35	40	35	40	20	20	15	20
		15 kW	90	100	45	60	50	60	30	30	25	25
		22.5 kW	125	150	70	80	70	80	40	40	30	35
³ Minimum Circuit Ampacity	Unit+ Electric Heat	5 kW	38	40	21	21	23	24	11	12	9	10
		7.5 kW	48	53	26	29	28	31	14	16	12	13
		10 kW	59	66	32	36	35	39	18	19	15	16
		15 kW	82	92	45	51	48	54	26	27	21	22
		22.5 kW	116	131	65	74	67	76	37	38	30	31
² Maximum Overcurrent Protection	Unit+ Electric Heat and (1) 0.5 HP Power Exhaust	5 kW	50	50	30	30	30	30	15	15	15	15
		7.5 kW	50	60	30	35	30	35	15	20	15	15
		10 kW	70	70	35	40	40	45	20	20	15	20
		15 kW	90	100	50	60	50	60	30	30	25	25
		22.5 kW	125	150	70	80	70	80	40	40	30	35
³ Minimum Circuit Ampacity	Unit+ Electric Heat and (1) 0.5 HP Power Exhaust	5 kW	40	42	22	23	24	26	11	13	9	10
		7.5 kW	50	55	28	31	30	33	15	16	12	13
		10 kW	61	68	34	38	37	41	19	20	15	16
		15 kW	84	94	47	53	50	56	26	28	21	22
		22.5 kW	118	133	67	76	69	78	38	39	30	31

ELECTRIC HEAT ACCESSORIES

Unit Fuse Block	Unit Only	10A26	10A27	10A27	10A29	10A29	10A29	10A29
	Unit + Power Exhaust	10A26	10A27	10A27	10A29	10A29	10A29	10A29

NOTE - All units have a minimum Short Circuit Current Rating (SCCR) of 5000 amps.

¹ Extremes of operating range are plus and minus 10% of line voltage.

² HACR type breaker or fuse.

³ Refer to National or Canadian Electrical Code manual to determine wire, fuse and disconnect size requirements.

ELECTRICAL DATA**5 TON****ZCA060S4**

¹ Voltage - 60hz		208/230V - 1 Ph	208/230V - 3 Ph		460V - 3 Ph		575V - 3 Ph	
Compressor	Rated Load Amps	22.1	13.5		8		5	
	Locked Rotor Amps	125	109		59		40	
Outdoor Fan Motor	Full Load Amps	1.7	1.7		1		0.9	
Power Exhaust (1) 0.5 HP	Full Load Amps	1.5	1.5		0.6		0.6	
Indoor Blower Motor	Horsepower	1.5	1	1.5	1	1.5	1	1.5
	Full Load Amps	11	4.6	6.6	2.1	3	1.7	2.4
² Maximum Overcurrent Protection	Unit Only	60	35	35	20	20	15	15
	With (1) 0.5 HP Power Exhaust	60	35	40	20	20	15	15
³ Minimum Circuit Ampacity	Unit Only	41	24	26	14	14	9	10
	With (1) 0.5 HP Power Exhaust	42	25	27	14	15	10	11

ELECTRIC HEAT DATA

Electric Heat Voltage			208V	240V	208V	240V	208V	240V	480V	480V	600V	600V
² Maximum Overcurrent Protection	Unit+ Electric Heat	5 kW	60	60	35	35	35	35	20	20	15	15
		7.5 kW	60	60	35	35	35	35	20	20	15	15
		10 kW	60	70	35	40	35	40	20	20	15	20
		15 kW	90	100	45	60	50	60	30	30	25	25
		22.5 kW	125	150	70	80	70	80	40	40	30	35
³ Minimum Circuit Ampacity	Unit+ Electric Heat	5 kW	41	41	24	24	26	26	14	14	9	10
		7.5 kW	48	53	26	29	28	31	14	16	12	13
		10 kW	59	66	32	36	35	39	18	19	15	16
		15 kW	82	92	45	51	48	54	26	27	21	22
		22.5 kW	116	131	65	74	67	76	37	38	30	31
² Maximum Overcurrent Protection	Unit+ Electric Heat and (1) 0.5 HP Power Exhaust	5 kW	60	60	35	35	40	40	20	20	15	15
		7.5 kW	60	60	35	35	40	40	20	20	15	15
		10 kW	70	70	35	40	40	45	20	20	15	20
		15 kW	90	100	50	60	50	60	30	30	25	25
		22.5 kW	125	150	70	80	70	80	40	40	30	35
³ Minimum Circuit Ampacity	Unit+ Electric Heat and (1) 0.5 HP Power Exhaust	5 kW	42	42	25	25	27	27	14	15	10	11
		7.5 kW	50	55	28	31	30	33	15	16	12	13
		10 kW	61	68	34	38	37	41	19	20	15	16
		15 kW	84	94	47	53	50	56	26	28	21	22
		22.5 kW	118	133	67	76	69	78	38	39	30	31

ELECTRIC HEAT ACCESSORIES

Unit Fuse Block	Unit Only	10A26	10A28	10A28	10A29	10A29	10A29	10A29
	Unit + Power Exhaust	10A26	10A28	10A28	10A29	10A29	10A29	10A29

NOTE - All units have a minimum Short Circuit Current Rating (SCCR) of 5000 amps.

¹ Extremes of operating range are plus and minus 10% of line voltage.² HACR type breaker or fuse.³ Refer to National or Canadian Electrical Code manual to determine wire, fuse and disconnect size requirements.

ELECTRIC HEAT CAPACITIES

Input Voltage	5 kW			7.5 kW			10 kW			15 kW			22.5 kW		
	No of Stages	kW input	Btuh Output	No of Stages	kW input	Btuh Output	No of Stages	kW input	Btuh Output	No of Stages	kW input	Btuh Output	No of Stages	kW input	Btuh Output
208	1	3.8	12,800	1	5.6	19,200	1	7.5	25,600	1	11.2	38,400	1	16.9	57,700
220	1	4.2	14,300	1	6.3	21,500	1	8.4	28,700	1	12.6	43,000	1	18.9	64,500
230	1	4.6	15,700	1	6.9	23,500	1	9.2	31,400	1	13.8	47,000	1	20.7	70,700
240	1	5.0	17,100	1	7.5	25,600	1	10.0	34,200	1	15.0	51,200	1	22.5	76,800
440	1	4.2	14,300	1	6.3	21,500	1	8.4	28,700	1	12.6	43,000	1	18.9	64,500
460	1	4.6	15,700	1	6.9	23,500	1	9.2	31,400	1	13.8	47,000	1	20.7	70,700
480	1	5.0	17,100	1	7.5	25,600	1	10.0	34,200	1	15.0	51,200	1	22.5	76,800
550	1	4.2	14,300	1	6.3	21,500	1	8.4	28,700	1	12.6	43,000	1	18.9	64,500
575	1	4.6	15,700	1	6.9	23,500	1	9.2	31,400	1	13.8	47,000	1	20.7	70,700
600	1	5.0	17,100	1	7.5	25,600	1	10.0	34,200	1	15.0	51,200	1	22.5	76,800

UNIT CLEARANCES - INCHES (MM)

UNIT WITH DOWNFLOW ECONOMIZER

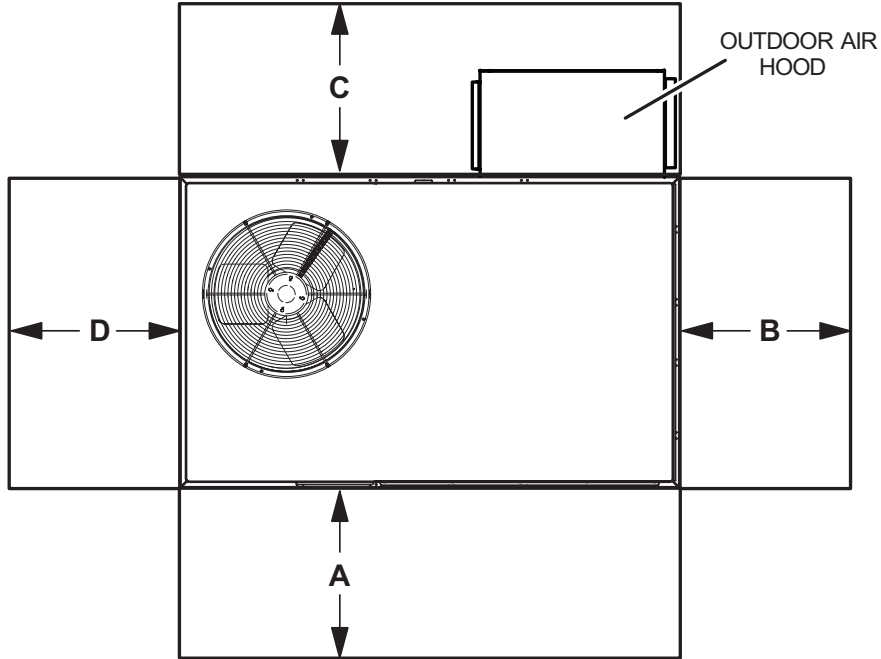

UNIT WITH HORIZONTAL ECONOMIZER

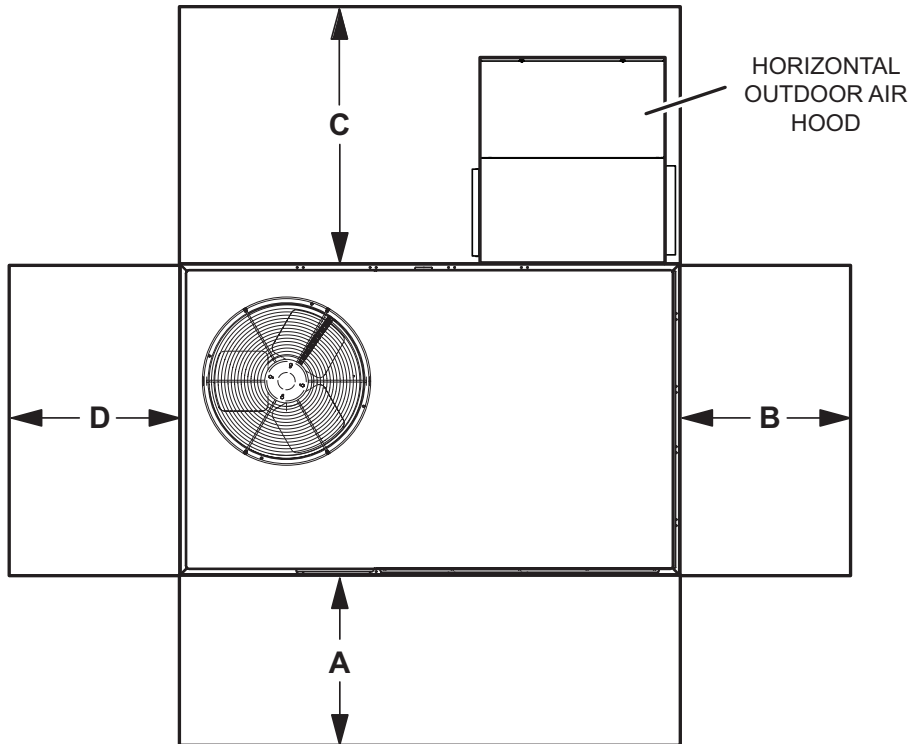

¹ Unit Clearance	A		B		C Downflow		C Horizontal		D		Top Clearance
	in.	mm	in.	mm	in.	mm	in.	mm	in.	mm	
Service Clearance	36	914	36	914	36	914	60	1524	36	914	Unobstructed
Minimum Operation Clearance	36	914	36	914	36	914	60	1524	36	914	

NOTE - Entire perimeter of unit base requires support when elevated above the mounting surface.

¹ Service Clearance - Required for removal of serviceable parts.

Minimum Operation Clearance - Required clearance for proper unit operation.

OUTDOOR SOUND DATA

Unit Model No.	Octave Band Linear Sound Power Levels dB, re 10 ⁻¹² Watts - Center Frequency - Hz							¹ Sound Rating Number (SRN) (dBA)
	125	250	500	1000	2000	4000	8000	
036	81	78	77	72	68	66	61	77
048	84	80	79	74	70	67	63	80
060	86	82	82	78	74	68	65	83

¹ Sound Rating Number according to ANSI/AHRI Standard 270-2008. "SRN" is the overall A-Weighted Sound Power Level, (LWA), dB (100 Hz to 10,000 Hz).

WEIGHT DATA

Model Number	Net				Shipping			
	Base		Max.		Base		Max.	
	lbs.	kg	lbs.	kg	lbs.	kg	lbs.	kg
036S	451	205	502	228	456	207	507	230
048S	465	211	516	234	470	213	521	236
060S	497	225	550	249	502	228	555	252

Base Unit - The unit with NO OPTIONS.

Max. Unit - The unit with ALL OPTIONS Installed. (Economizer, etc.)

OPTIONS / ACCESSORIES

		Shipping Weights	
		lbs.	kg
ECONOMIZER			
Economizer			
Economizer, Includes Outdoor Air Hood and Barometric Relief Dampers with Hood	Downflow - Z1ECON30A-1	65	29
	Horizontal - Z1ECON16A-1	92	42
OUTDOOR AIR			
Outdoor Air Dampers			
Motorized	Z1DAMP21A-1	30	14
Manual	Z1DAMP11A-1	23	10
POWER EXHAUST			
Standard Static	Downflow	54	24
	Horizontal	41	19
ELECTRIC HEAT			
	5 kW - Z1EH0050AN1	25	11
	7.5 kW - Z1EH0075AN1	26	12
	10 kW - Z1EH0100AN1	27	12
	15 kW - Z1EH0150AN1	27	12
	22.5 kW - Z1EH0225AN1	29	13
ROOF CURBS - DOWNFLOW			
Clip Curb			
8 in. height	Z1CURB40A-1	80	36
14 in. height	Z1CURB41A-1	95	43
18 in. height	Z1CURB42A-1	110	50
24 in. height	Z1CURB43A-1	125	57
Standard			
14 in. height	Z1CURB10A-1	106	48
CEILING DIFFUSERS			
Step-Down	RTD9-65-R	67	30
Flush	FD9-65-R	37	17

DIMENSIONS - INCHES (MM)

Model No.	CORNER WEIGHTS																CENTER OF GRAVITY							
	AA				BB				CC				DD				EE				FF			
	Base		Max.		Base		Max.		Base		Max.		Base		Max.		Base		Max.		Base		Max.	
	lbs.	kg	lbs.	kg	lbs.	kg	lbs.	kg	lbs.	kg	lbs.	kg	lbs.	kg	lbs.	kg	in.	mm	in.	mm	in.	mm	in.	mm
036	116	53	132	60	107	49	135	61	109	50	119	54	118	54	116	53	39.5	1003	37.5	953	23.25	591	25	635
048	120	54	135	61	110	50	139	63	113	51	122	55	122	55	119	54	39.5	1003	37.5	953	23.25	591	25	635
060	128	58	144	65	118	54	148	67	121	55	130	59	131	59	127	58	39.5	1003	37.5	953	23.25	591	25	635

Base Unit - The unit with NO OPTIONS.

Max. Unit - The unit with ALL OPTIONS Installed. (Economizer, largest blower motor, etc.).

BOTTOM POWER ENTRY

Holes required for Optional Bottom Power Entry Kit

	Threaded Conduit Fittings (Provided in Kit)	Wire Use	Hole Diameter Required in Unit Base (Max.)
A	1/2	ACC	7/8 (23)
B	1/2	24V	7/8 (23)
C	3/4	POWER	1-1/8 (29)

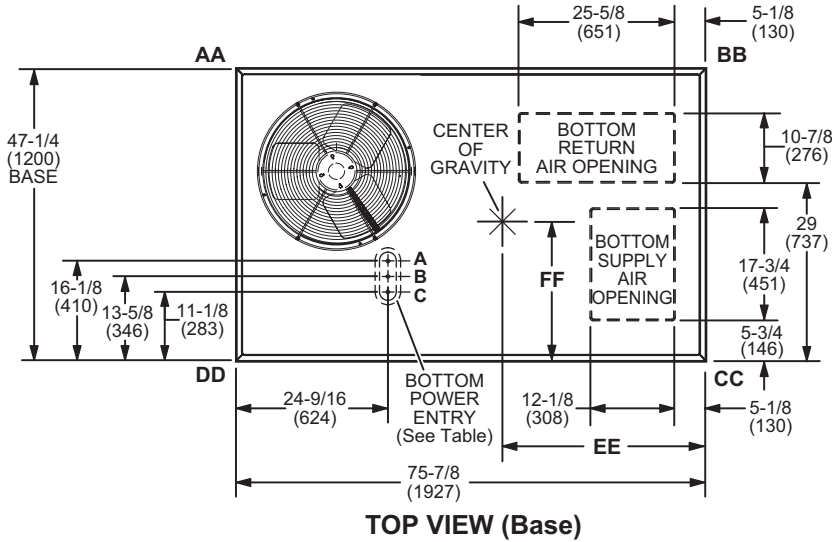

TOP VIEW (Base)

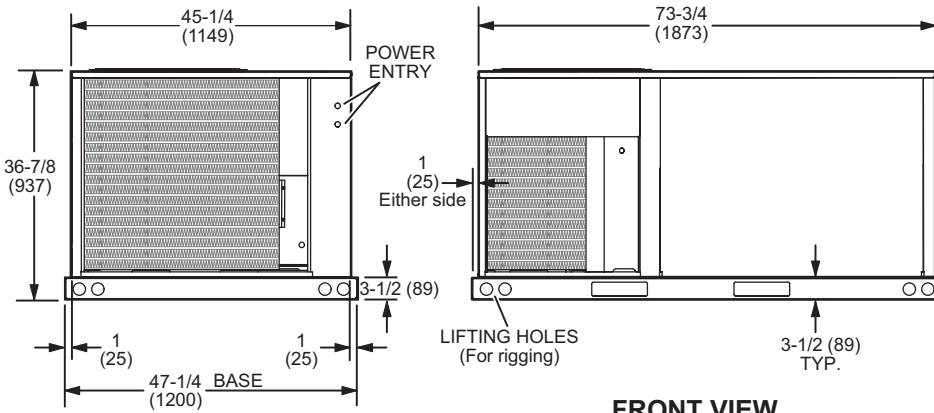

FRONT VIEW

END VIEW

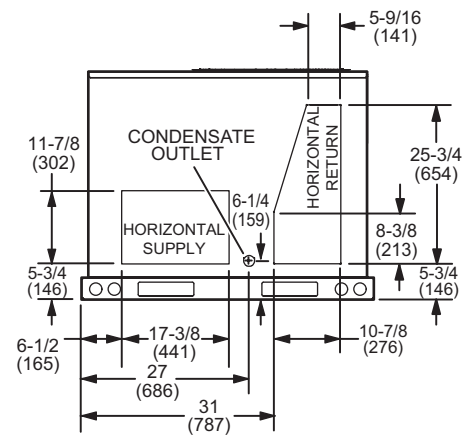

END VIEW

ACCESSORY DIMENSIONS - INCHES (MM)

OUTDOOR AIR HOOD DETAIL FOR OPTIONAL ECONOMIZER (Downflow Applications)

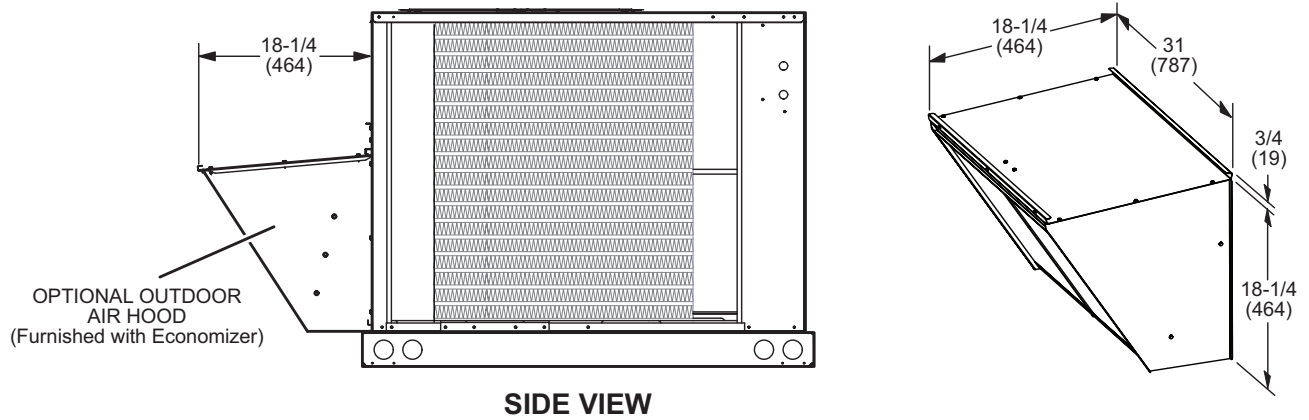

OUTDOOR AIR DAMPER HOOD DETAIL FOR OPTIONAL MANUAL OR MOTORIZED OUTDOOR AIR DAMPERS (Downflow or Horizontal Applications)

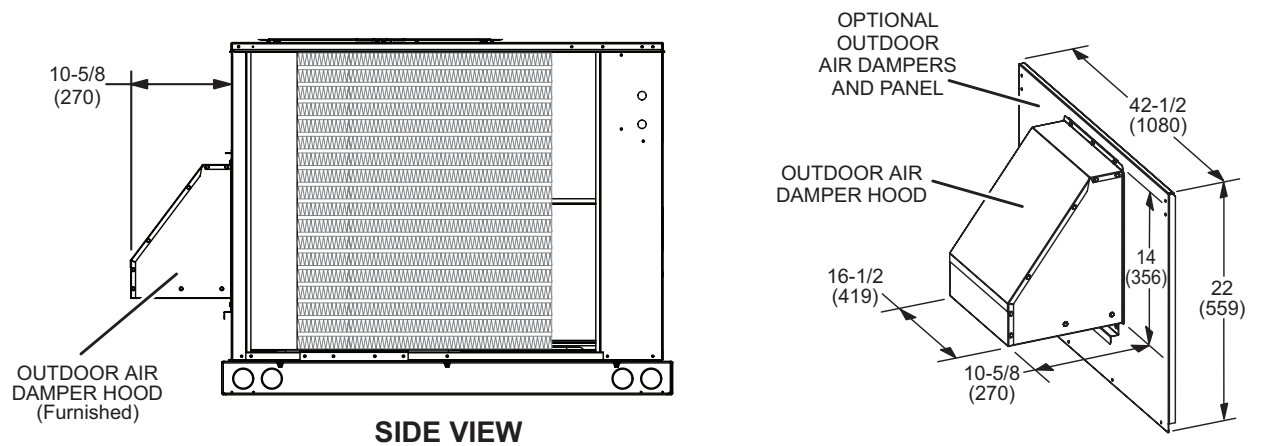

ACCESSORY DIMENSIONS - INCHES (MM)

**OUTDOOR AIR HOOD DETAIL WITH OPTIONAL ECONOMIZER AND BAROMETRIC RELIEF DAMPERS
(Horizontal Applications)**

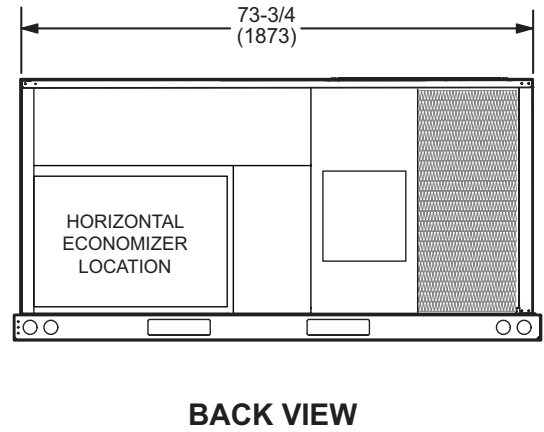
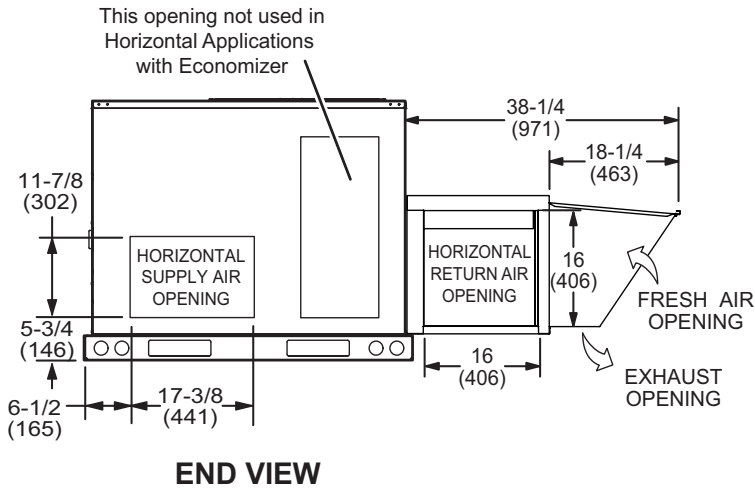
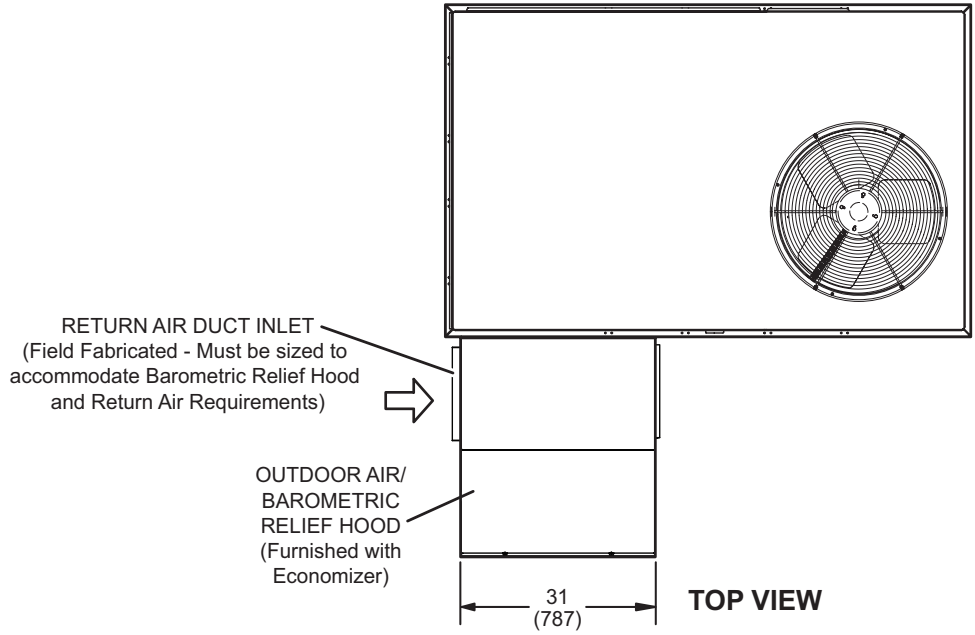

Note - Return Air Duct and Transition must be supported.

ACCESSORY DIMENSIONS - INCHES (MM)

CLIP CURB - DOUBLE DUCT OPENING

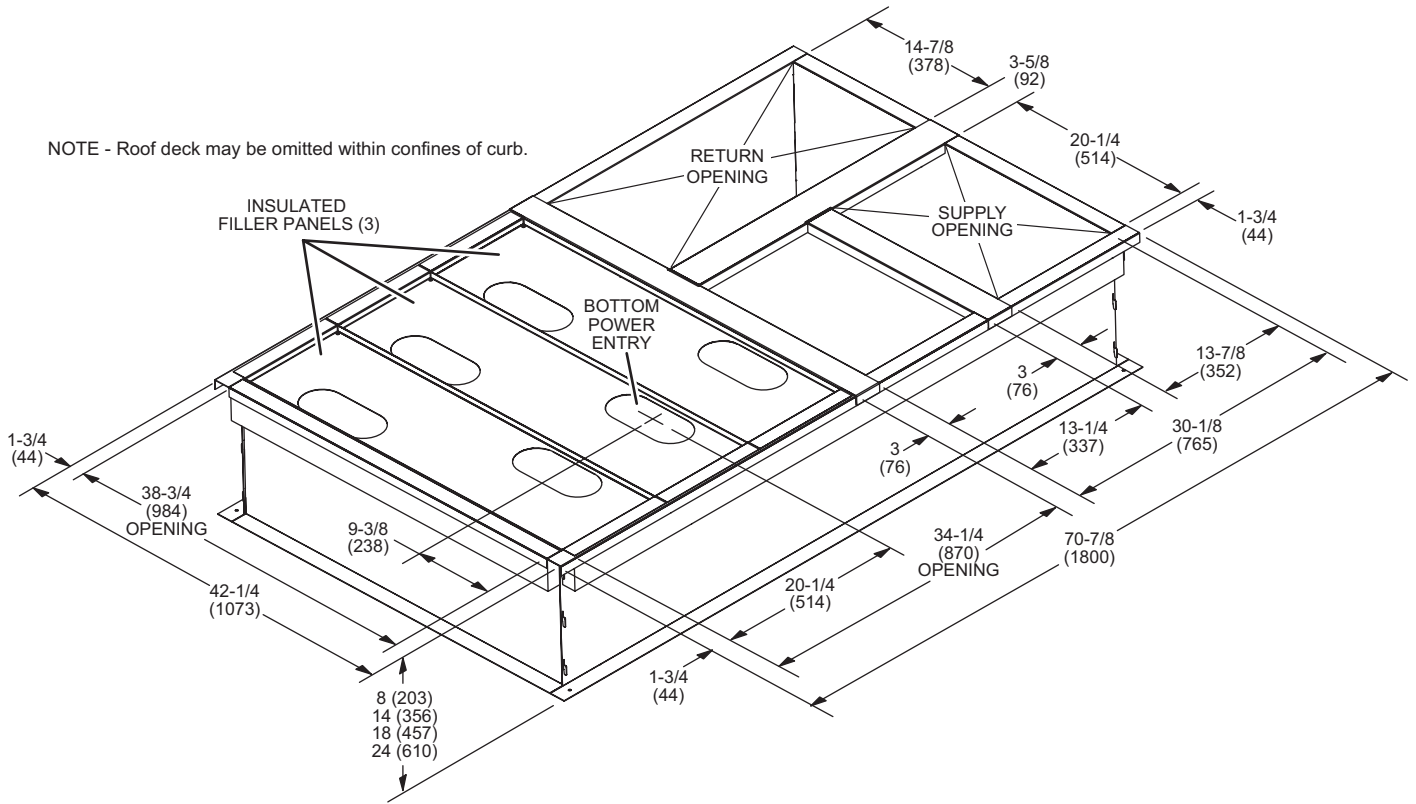

TYPICAL FLASHING DETAIL FOR ROOF CURB

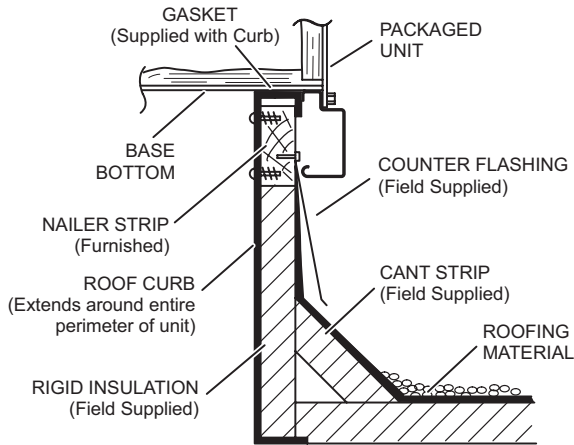

DETAIL ROOF CURB

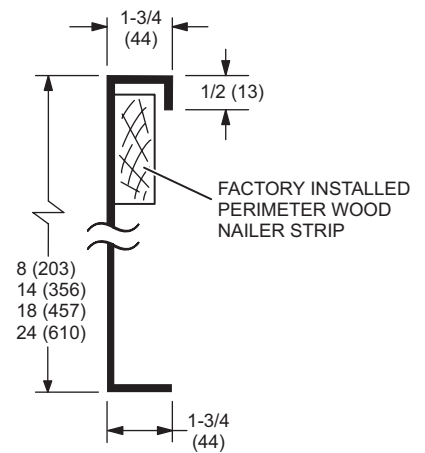

ACCESSORY DIMENSIONS - INCHES (MM)

STANDARD ROOF CURBS - DOUBLE DUCT OPENING

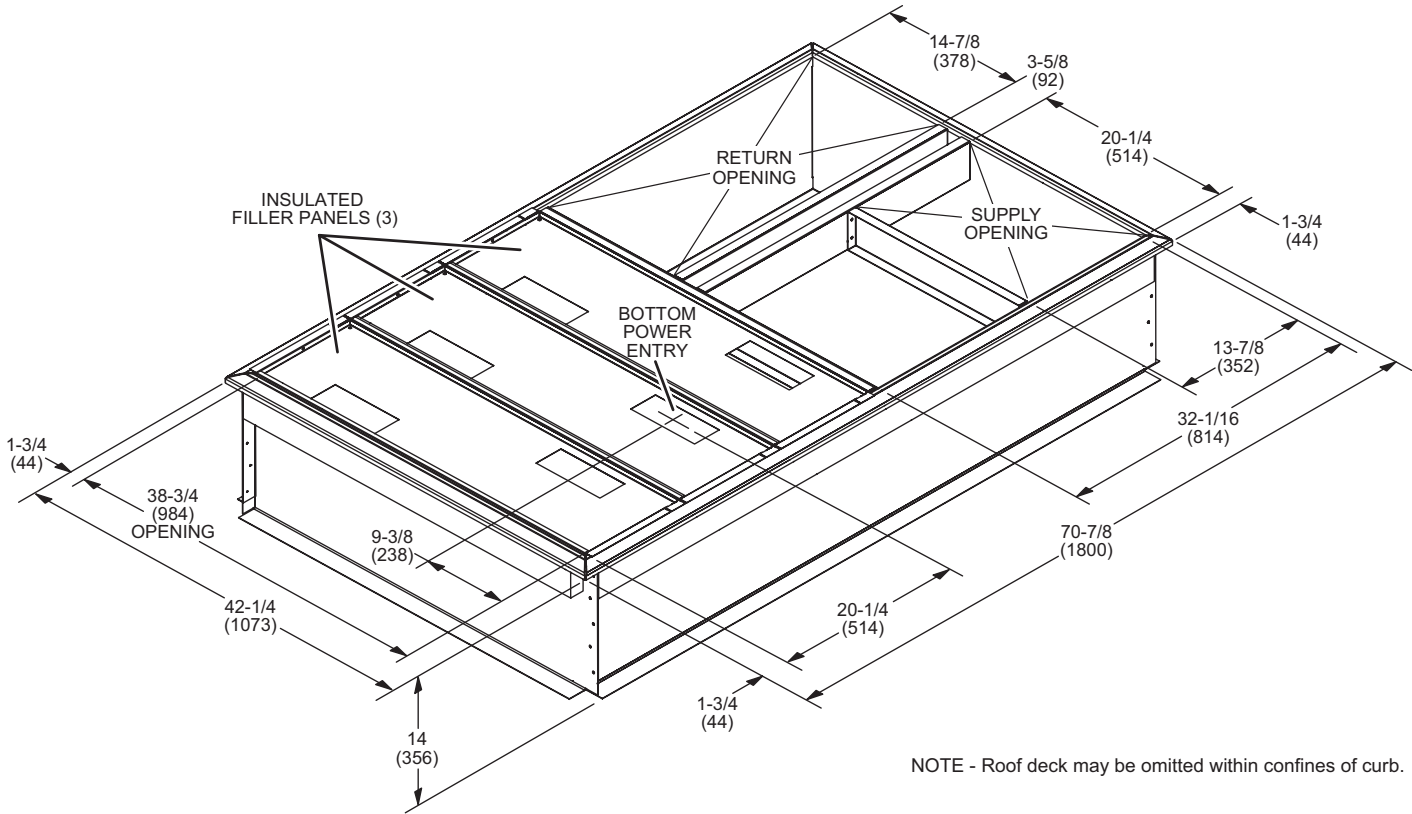

TYPICAL FLASHING DETAIL FOR ROOF CURB

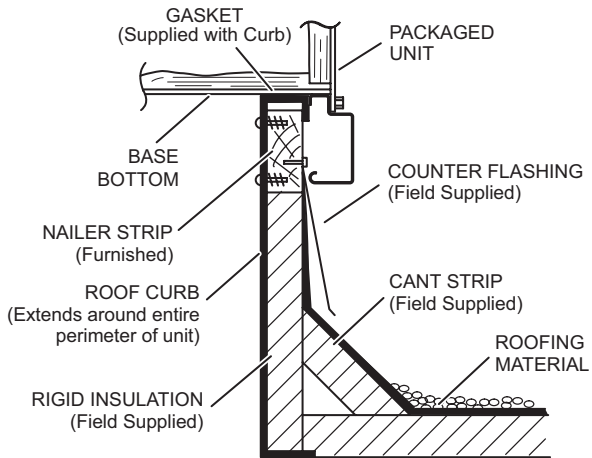

DETAIL ROOF CURB

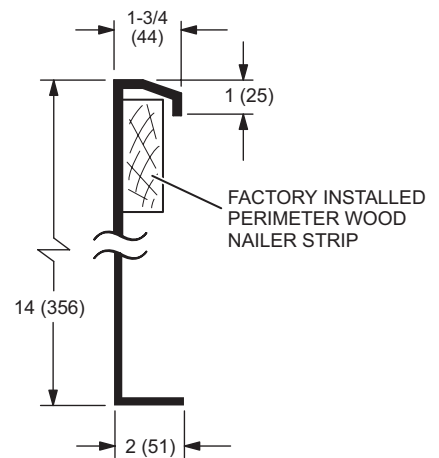

ACCESSORY DIMENSIONS - INCHES (MM)

COMBINATION CEILING SUPPLY AND RETURN DIFFUSERS

STEP-DOWN CEILING DIFFUSER

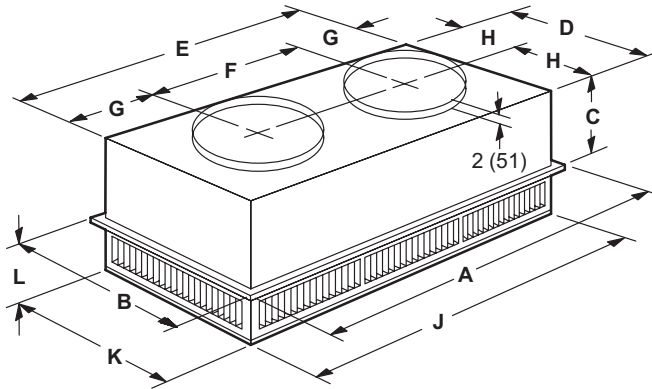

FLUSH CEILING DIFFUSER

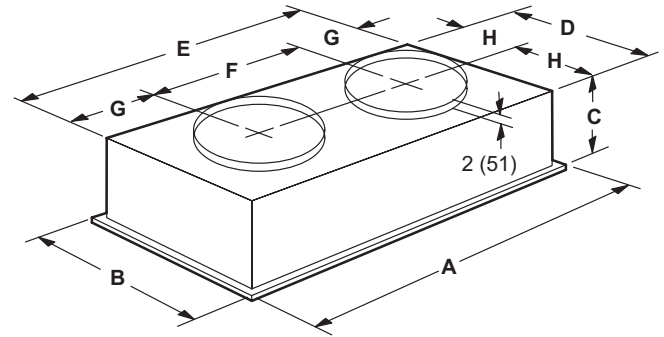

Model Number		RTD9-65
A	in.	47-5/8
	mm	1159
B	in.	23-5/8
	mm	600
C	in.	11-3/8
	mm	289
D	in.	21-1/2
	mm	546
E	in.	45-1/2
	mm	1156
F	in.	22-1/2
	mm	572
G	in.	11-1/2
	mm	292
H	in.	10-3/4
	mm	273
J	in.	45-1/2
	mm	1156
K	in.	21-1/2
	mm	546
L	in.	7-1/8
	mm	181
Duct Size	in.	18 round
	mm	457 round

Model Number		FD9-65
A	in.	47-5/8
	mm	1159
B	in.	23-5/8
	mm	600
C	in.	13-1/2
	mm	343
D	in.	21
	mm	533
E	in.	45
	mm	1143
F	in.	22-1/2
	mm	572
G	in.	11-1/4
	mm	286
H	in.	10-1/2
	mm	267
Duct Size	in.	18 round
	mm	457 round

REVISIONS

Sections	Description of Change
Options/Accessories	Revised crankcase heater usage for 048 models.



Visit us at www.allied-commercial.com

For the latest technical information, visit us at www.allied-commercial.com

Contact us at 1-800-738-4000

NOTE - Due to Allied Commercial ongoing commitment to quality, Specifications, Ratings and Dimensions subject to change without notice and without incurring liability. Improper installation, adjustment, alteration, service or maintenance can cause property damage or personal injury. Installation and service must be performed by a qualified installer and servicing agency.