

## NON-CONDENSING CONCENTRIC VENT

Fully modulating, gas fired, tankless water heater with sealed combustion and power vented flue. Supplies hot water to domestic hot water systems (directly or indirectly) and can be used with water storage tanks, recirculation systems, and/or combined domestic & heating applications.

### FEATURES:

#### CONCENTRIC VENT DESIGN

#### FIELD CONVERTIBLE FROM NATURAL GAS TO PROPANE

#### COMPLIES WITH SCAQMD RULE 1146.2 AND OTHER AIR QUALITY MANAGEMENT DISTRICTS WITH SIMILAR NOx EMISSION REQUIREMENTS OF 14 NG/J OR 20 PPM

#### MAXIMUM FLOW RATES UP TO 10.0 GPM

#### COPPER HEAT EXCHANGER

- 25x better heat transfer than stainless steel thus stabilizing outgoing water temperature quicker and reducing pressure drop across the heat exchanger

#### INDOOR MODELS ONLY

#### ATI-510C CAN BE USED IN BOTH RESIDENTIAL AND COMMERCIAL APPLICATIONS

- Easy-Link up to 4 units (no additional parts or accessories needed)
- Multi-link up to 20 units

#### COMPLIES WITH LEAD FREE STANDARDS

### SAFETY FEATURES:

- Built-in Freeze Protection
- Manual Reset Hi-Limit (Up to 194°F)
- Overheat Cutoff Fuse
- Inlet and Outlet Thermistors for Constant Temperature Monitoring
- Air Fuel Ratio Rod
- Flame Sensor

### VENTING AND COMBUSTION

- Direct vent APNC35 concentric vent system
- Vertical or Horizontal Vent Termination Installation
- 43' Max Length, 4 Elbows max (87° elbows = 5' equivalent length)
- Power Direct Vent
- Electronic Ignition - No Pilot Light

### OPTIONAL ACCESSORIES

- Isolation Valve Kit (9007604005)
- Remote Control (9009069005)
- Product Preserver (9008871005)
- Multi-Unit Controller (9008300005)

### WARRANTY

- 15-year limited warranty on heat exchanger in residential applications
- 6-year limited warranty on heat exchanger in commercial applications
- 5-year limited warranty on all parts

### INDOOR MODELS

ATI-110C, ATI-310C, ATI-510C



(510C models only)



ANSI Z21.10.3

Model Number	Type	Gas Consumption Input		Inlet Gas Pressure*		Energy Factor (EF)	Maximum GPM**	Hot/Cold Connections	Gas Connection	Dimensions in Inches			Unit Weight (lbs)
		Minimum BTU/H	Maximum BTU/H	Minimum in. W.C.	Maximum in. W.C.					Height	Width	Depth	
<b>Indoor Models</b>													
<b>ATI-110C-N</b>	Natural	15,000	140,000	4.0	10.5	0.82	6.6	3/4" NPT	3/4" NPT	20-1/2	13-3/4	10-1/2	51
<b>ATI-310C-N</b>	Natural	15,000	190,000	4.0	10.5	0.82	8	3/4" NPT	3/4" NPT	20-1/2	13-3/4	10-1/2	51
<b>ATI-510C-N***</b>	Natural	15,000	199,000	4.0	10.5	0.82	10	3/4" NPT	3/4" NPT	20-1/2	13-3/4	10-1/2	51

15-150 psi water pressure. 40 psi or above recommended for maximum flow.

\*For Propane, minimum inlet gas pressure is 8.0 in. W.C. and maximum inlet gas pressure is 14.0 in. W.C.

\*\*Current numbers based on factory testing; 0.5 gpm required for activation; 0.4 gpm required for continuous fire after initial ignition.

\*\*\*Suitable for commercial applications.

Certified from sea level to 10,100 ft. elevations.

### INDOOR MODEL DIMENSIONS CLEARANCES: TOP 12", BOTTOM 12", FRONT 4", BACK .5", SIDES 3"

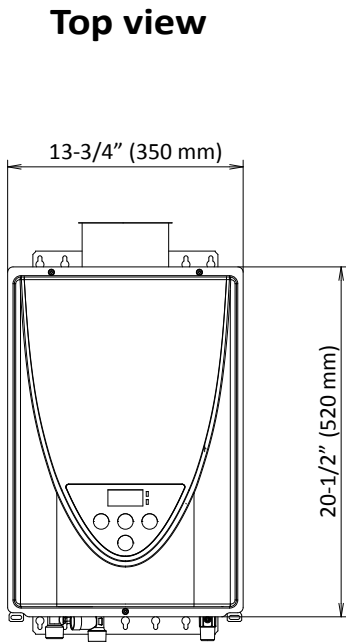
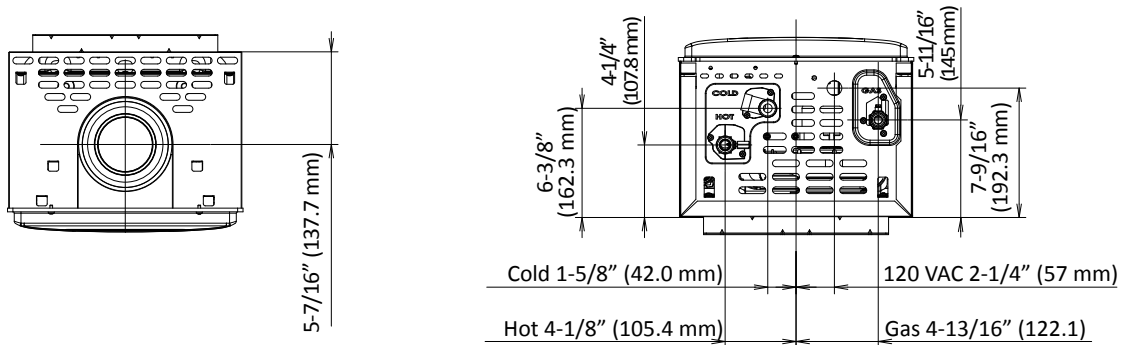

**Front view**

**Side view**

## 110C MODEL

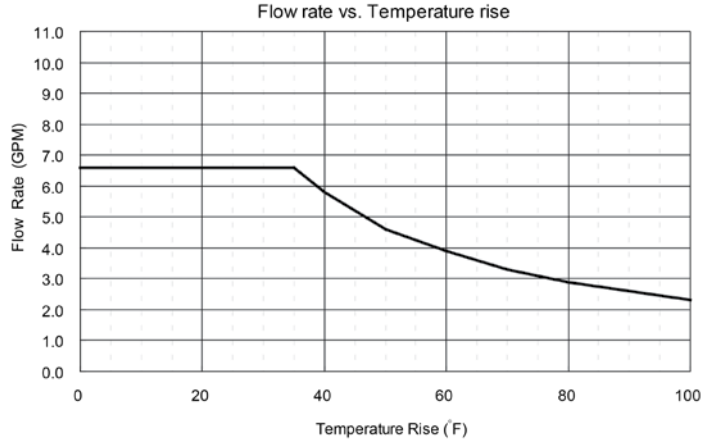
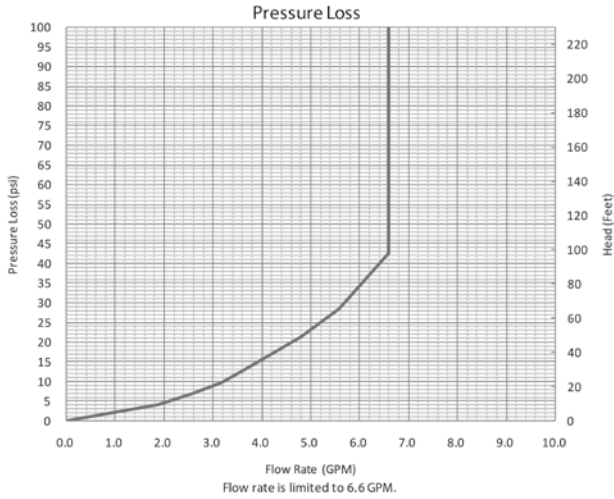

## 310C MODEL

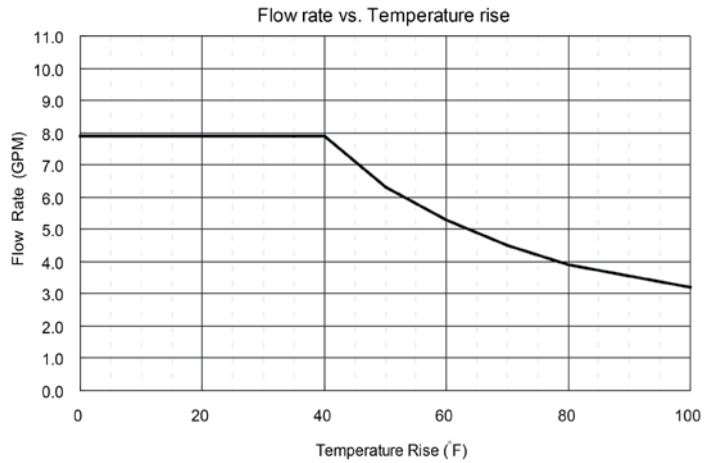
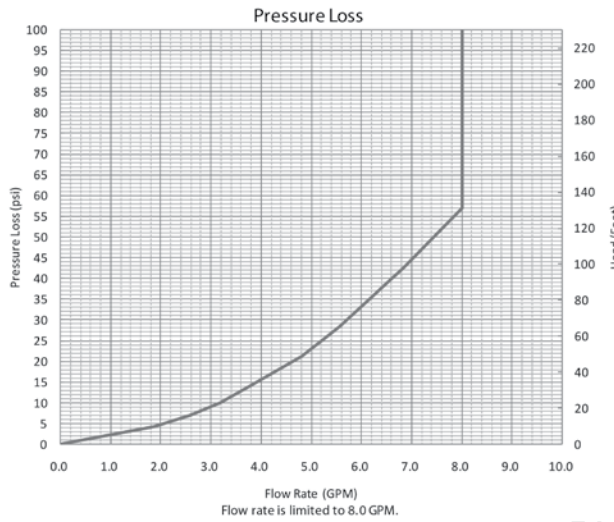

## 510C MODEL

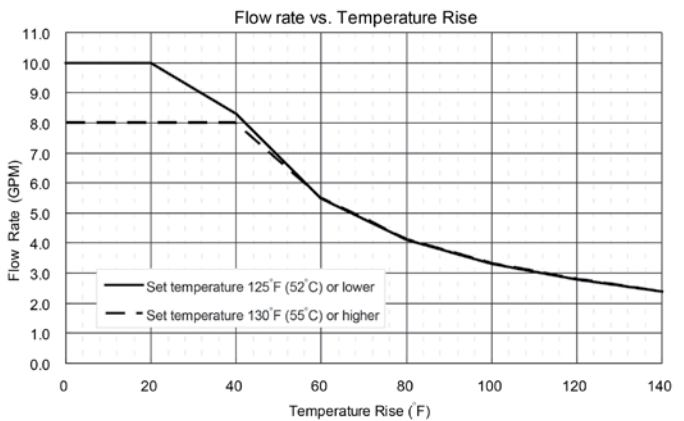
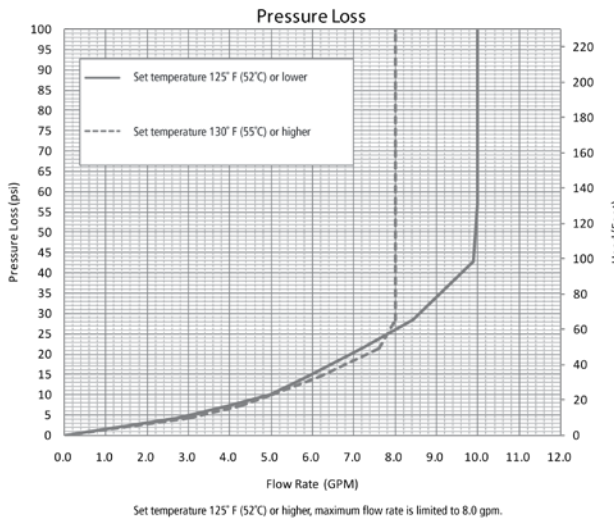



## Residential Gas Water Heaters

### SUGGESTED SPECIFICATIONS FOR THE ATI-510C-N

The fully modulating, on-demand, non-condensing gas fired tankless water heater shall be A. O. Smith Tankless Water Heater model ATI-510C-N, having a maximum input rating of 199,000 Btu/h and available in natural gas (NG). For use with propane (LP) gas, the heater shall be field converted using the factory supplied conversion kit. The conversion kit shall be supplied with the heater. The heater shall have  $\frac{3}{4}$  in. male NPT water and gas connections. The inlet gas supply pressures shall be 4.0 in. WC (min.) up to 10.5 in. WC (max) for NG and 8.0 in. WC (min.) up to 14 in. WC (max.) for LP. The heater shall incorporate an integrated temperature controller that will provide diagnostic information, fault history, and heater set temperature. The heater shall operate using 120 V / 60 Hz power source. The heater will incorporate a factory installed power cord.

The indoor heater shall be vented with a 3"/5" direct vent APNC35 concentric vent with a length not to exceed 43 ft. (equivalent), terminating horizontally or vertically with no more than four 87° elbows.

The water heater shall use a commercial grade copper alloy, fin tube heat exchanger with quick release brass or bronze waterways. The heater shall be controlled by an onboard solid-state printed circuit board which uses the following factory installed components: thermistors to monitor water temperature; a flow sensor to measure flow rate; a flame sensor to monitor combustion; and an air-fuel ratio rod to measure and adjust air input in order to maintain optimal combustion efficiency. The heater also consists of inline fusing and surge absorbers for electrical surge protection, an electronic spark igniter, aluminized stainless steel burners, hi-limit switch to monitor water temperature, modulating gas valve, overheat cutoff fuse, and dual freeze protection that incorporates heating blocks and the ability to automatically fire the heater to protect the heat exchanger.

The heater can manifold to Easy-Link up to 4 heaters to provide additional capacity. The Easy-Link controls shall be built onto the onboard solid-state printed circuit board and does not require external controls. The linking control wire shall be supplied with the heater. A Multi-Unit controller, 9008300005, can manifold 5-20 heaters. The Easy-Link and Multi-Unit Controller shall modulate the system for the most efficient performance. The Easy-Link and Multi-Unit Controller shall rotate the priority heater every 12 hours of operation time or 100 starts for balanced duty/cycle operation.

The heater models are design certified by CSA according to ANSI Z21.10.3, approved for sale in the United States, has a minimum energy factor of 0.82, meets the energy efficiency requirements of the U. S. Department of Energy and ASHRAE 90.1, complies with SCAQMD Rule 1146.2 and other air quality districts with similar requirements for low NO<sub>x</sub> emissions of 14 ng/J or 20 ppm, and shall be certified to NSF 5 Standards.