

# INSTALLATION INSTRUCTIONS

## Gas Changeover Kit

Natural to LP/Propane (68W77) and LP/Propane to Natural (70W88)  
For Modulating Gas Products  
97/98(A\*MV, NF\*V, G\*M)

### ⚠ WARNING

This conversion kit is to be installed by a licensed professional service technician (or equivalent) or other qualified agency in accordance with the manufacturer's instructions, all codes and requirements of the authority having jurisdiction in the U.S.A., and the requirements of the CSA-B149 installation codes in Canada. If the information in these instructions is not followed exactly, a fire, an explosion, or production of carbon monoxide may result, causing property damage, personal injury or loss of life. The qualified agency performing this work assumes responsibility for this conversion.

### Shipping and Packing List

Package 1 of 1 contains:

- 1 - Gas Valve
- 12 - Main burner orifices (Nat. 0.0630) or (LP 0.034)
- 1 - Gas converter sticker
- 1 - Nameplate conversion sticker
- 1 - Low gas inlet pressure switch (S145)
- 1 - Gas valve inlet fitting
- 1 - Wire harness

Check the Gas Changeover kit for shipping damage. If you find any damage, immediately contact the last carrier.

### General

#### Application

Use natural to LP/propane gas conversion kit 68W77 to convert modulating gas furnaces from natural gas to regulated LP/propane gas.

Use LP/propane to natural gas conversion kit 70W88 to convert modulating gas furnaces from regulated LP/propane to natural gas.

### ⚠ DANGER

#### DANGER OF EXPLOSION!

There are circumstances in which odorant used with LP/propane gas can lose its scent. In case of a leak, LP/propane gas will settle close to the floor and may be difficult to smell. An LP/propane leak detector should be installed in all LP applications.



**DO NOT** attempt to bleed the gas lines of air. Call your local gas provider. As with any mechanical equipment, personal injury can result from contact with sharp sheet metal edges. Be careful when you handle this equipment.

### ⚠ CAUTION

As with any mechanical equipment, personal injury can result from contact with sharp sheet metal edges. Be careful when you handle this equipment.



\*506615-03\*

Save these instructions for future reference

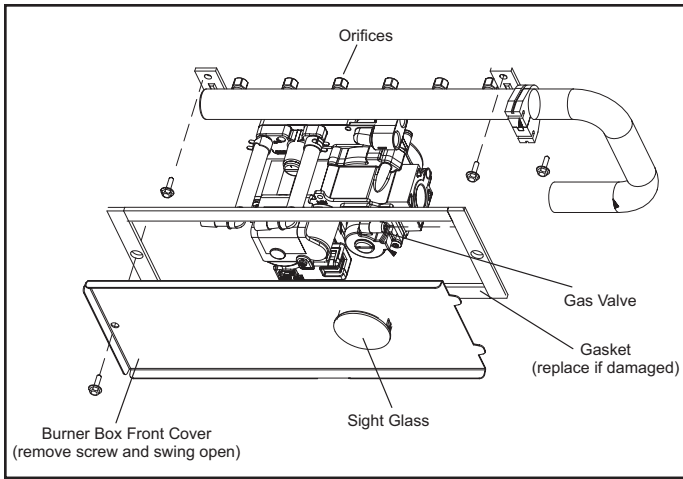

**Figure 1. Gas Valve Manifold Assembly**

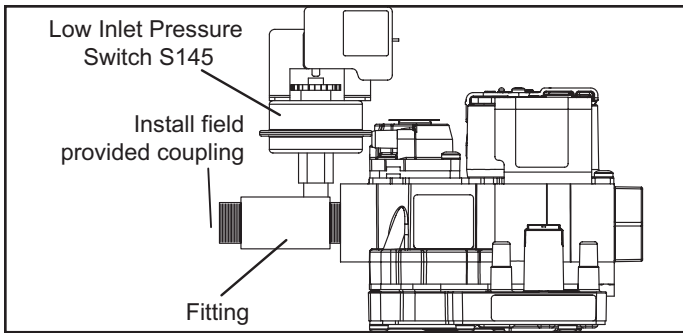

**Figure 2.**

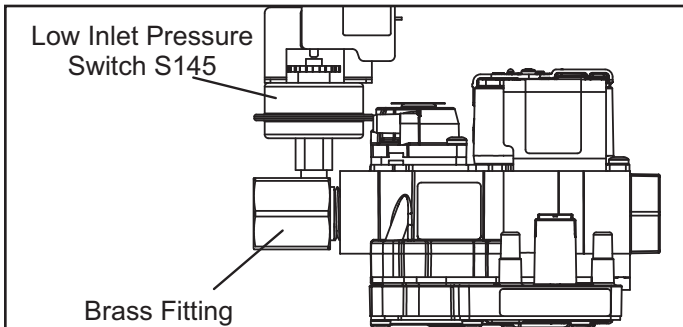

**Figure 3. Gas Valve with Low Inlet Pressure Switch**

1. Set the thermostat to the lowest setting. Shut off the gas supply to the furnace, then disconnect the electrical power.
2. Remove the access panel. Move the automatic gas valve switch to the OFF position. See Figure 5.
3. Remove the screw that secures the burner box front cover to the burner box. Set the front cover and screw aside. If gasket is damaged, replace.
4. Disconnect the gas supply and the two wire plugs at the gas valve. Disconnect the tubing from the gas valve.
5. Remove the screws that secure the manifold to the burner box. Remove the manifold/valve assembly from the unit.

6. Replace the burner orifices with those provided. Torque to 75-90 in-lbs. Do not use thread sealant.
7. Remove the existing gas valve from the gas manifold.
8. Clean the gas manifold threads. Skip the outer three threads, then apply sealant (pipe dope) to a minimum five threads.

**⚠ IMPORTANT**

**DO NOT** use pipe dope or a pipe sealant on gas orifice threads. Compounds used on threaded joints of gas piping must be resistant to the actions of liquified petroleum gases

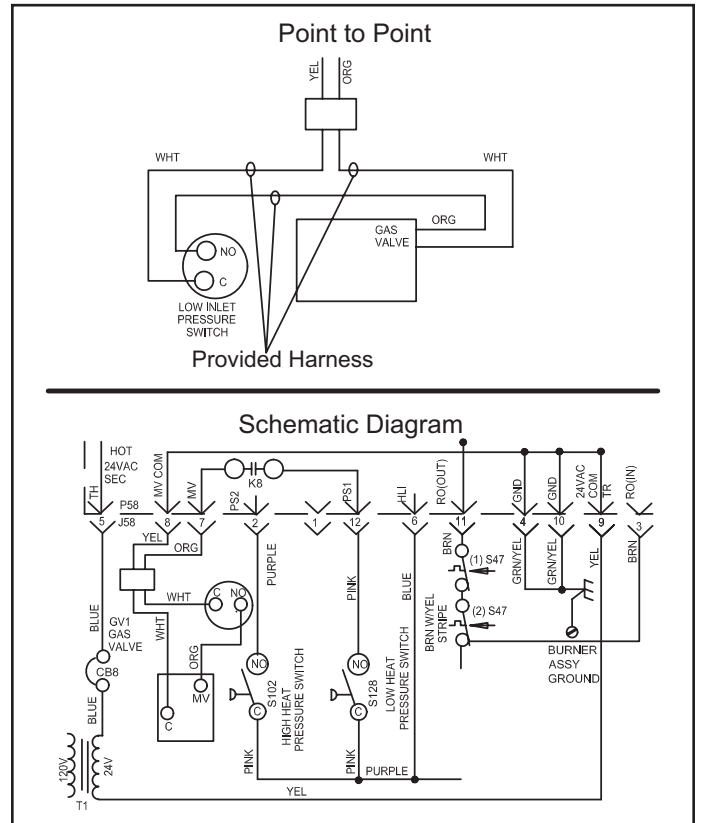

**Figure 4. Low Inlet Pressure Switch (S145) Wiring**

9. Thread the replacement gas valve onto the gas manifold, tightened to a minimum of 350 in. lbs.
10. Re-install the manifold/gas valve assembly and burner box cover.
11. Thread provided fitting to gas valve inlet until hand tight. Using properly sized wrench, tighten fitting 2 to 3 full turns being careful to position the side port to allow clearance for the pressure switch and harness. See Figure 2 or Figure 3.

**NOTE:** Never use channel lock pliers or a pipe wrench on the fitting.

**NOTE:** Some installations may require the pressure

switch and fitting assembly to be positioned differently than shown in Figure 2 or Figure 3.

12. Thread the gas supply to the fitting until hand tight. A field provided coupling may be needed. See Figure 2. Using properly sized wrench to support fitting, tighten supply line into fitting 2 to 3 full turns to achieve leak free joint.

**NOTE:** Do not over tighten. (Maximum 3 full turns past hand tight for 1/2" NPT per ASME B1.20.1-2013).

13. Thread pressure switch (S145) to fitting 2 to 3 turns past hand tight, then wire as shown in Figure 4.
14. Reconnect tubing to gas valve.
15. Restore the electrical power to the unit.
16. Inspect all sides of assembly. Turn on gas supply. **Immediately check the entire fitting surface and assembly joints for gas leaks.**

### ▲ IMPORTANT

Carefully check all piping connections at the valve for gas leaks. **DO NOT** use matches, candles, open flames or other means of ignition to check for gas leaks. Use a soap solution or other preferred means.

17. On the nameplate conversion sticker, mark the appropriate box that corresponds to the unit model number. Affix the sticker next to unit nameplate.
18. Complete the information required on the converter sticker: date, name, and address. Affix sticker to the exterior of the unit in a visible area.
19. Follow the steps given in the start-up and adjustment section.
20. Energize the thermostat several times to ensure the ignition control is operating and that the ignitor glows.
21. Replace the access panel.

### ▲ CAUTION

Some soaps used for leak detection are corrosive to certain metals. Carefully rinse piping thoroughly after leak test has been completed. **DO NOT** use matches, candles, flame or other sources of ignition to check for gas leaks.

## Start-Up & Adjustment

### Before Placing The Unit Into Operation

Smell all around the appliance area for gas. Be sure to smell next to the floor because some gas is heavier than air and will settle on the floor.

Use only your hand to move the gas control switch. Never use tools. If the switch will not move by hand, do not try to repair it. Force or attempted repair may result in a fire or explosion.

## Placing the Unit into Operation

### ▲ IMPORTANT

Follow the lighting instructions provided on the unit. If lighting instructions are not available, refer to the following section.

Units are equipped with an integrated ignition system. **Do not** attempt to manually light burners on this furnace. The integrated ignition control automatically lights the burners each time the thermostat calls for heat.

1. **STOP!** Read the safety information at the beginning of this section.
2. Set the thermostat to its lowest setting.
3. Turn **OFF** all electrical power to the furnace.
4. **Do not** try to light the burners by hand.
5. Remove the unit access panel.
6. Move the switch on the gas valve to **OFF**. Do not force the switch. See Figure 5.

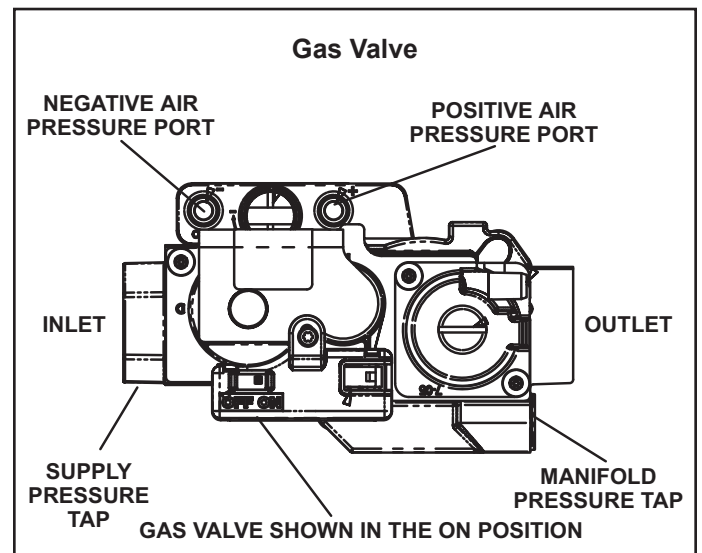

Figure 5.

7. Wait five (5) minutes for any gas to clear out. If you then smell gas, **STOP!** Immediately call your gas supplier from a neighbor's phone. Follow the gas supplier's instructions. If you do not smell gas, go to the next step.
8. Move the switch on the gas valve to **ON**.
9. Replace the unit access panel.
10. Turn on all electrical power to the unit.

- Set the thermostat to desired setting.
- If the furnace will not operate, see section "Turning Gas Off to the Unit" and call your service technician or gas supplier.

### Turning Off Gas to the Unit

- Set the thermostat to its lowest setting.
- Turn off all the electrical power to the unit.
- Remove the access panel.
- Move the switch on the gas valve to OFF. Do not force the switch.

### Gas Pressure Measurement

**NOTE:** To obtain an accurate reading, shut off all other gas appliances connected to meter.

Gas Meter Clocking Chart				
Unit Input	Seconds for One Revolution			
	Natural		LP/Propane	
	1 cu ft Dial	2 cu ft Dial	1 cu ft Dial	2 cu ft Dial
-070	55	110	136	272
-090	41	82	102	204
-110	33	66	82	164
-135	27	54	68	136
Natural - 1000 Btu/cu ft			LP - 2500 Btu/cu ft	

Table 1.

The furnace should operate at least 5 minutes before checking gas flow. Determine time in seconds for two revolutions of gas through the meter. (Two revolutions assures a more accurate time.) Divide by two and compare to time in Table 1. If manifold pressure matches Table 2 and rate is incorrect, check gas orifices for proper size and restriction. Remove temporary gas meter if installed.

**NOTE:** To obtain an accurate reading, shut off all other gas appliances connected to meter.

### Measuring & Adjusting the Manifold Pressure

To correctly measure manifold pressure, the differential pressure between the positive gas manifold and the negative burner box must be considered. Use a pressure test adapter kit to assist in measurement.

- Remove the threaded plug from the outlet side of the gas valve and install a field provided barbed fitting. Connect test gauge "+" connection to barbed fitting to measure manifold pressure.
- Tee into the gas valve regulator vent hose and connect test gauge "-" connection.
- Start unit on low heat (40% rate) and allow 5 minutes for unit to reach steady state.
- While waiting for the unit to stabilize, notice the flame. Flame should be stable and should not lift from burner. Natural gas should burn blue.
- After allowing unit to stabilize for 5 minutes, record manifold pressure and compare to value given in Table 2.
- Repeat steps 3, 4 and 5 on high heat.

**NOTE:** Shut unit off and remove manometer as soon as an accurate reading has been obtained. Take care to replace pressure tap plug.

**NOTE:** During this test procedure, the unit will be overfiring:

- Operate unit only long enough to obtain accurate reading to prevent overheating heat exchanger.
- Attempts to clock gas meter during this procedure will be inaccurate. Measure gas flow rate only during normal unit operation.

### CAUTION

Do not attempt to make adjustments to the gas valve.

### Supply Pressure Measurement

A threaded plug on the inlet side of the gas valve provides access to the supply pressure tap. Remove the threaded plug, install a field provided barbed fitting and connect a manometer to measure supply pressure. Replace the threaded plug after measurements have been taken.

### Proper Combustion

The furnace should operate minimum 15 minutes with correct manifold pressure and gas flow rate before checking combustion. Take combustion sample beyond the flue outlet. The maximum carbon monoxide reading should not exceed 100 ppm. See furnace Unit Information manual for proper CO<sub>2</sub>.

Model Input Size	Manifold Pressure at All Altitudes (in. w.c.)				Supply Line Pressure at All Altitudes (in. w.c.)			
	Low Fire (40% rate)		High Fire (100% rate)		Natural Gas		LP/Propane	
	Natural Gas	LP/Propane	Natural Gas	LP/Propane	Min.	Max.	Min.	Max.
-070	0.4 - 0.6	1.2 - 1.8	3.2 - 3.8	9.5 - 10.5	4.5	10.5	11.0	13.0
-090								
-110								
-135								

**NOTE:** Values given in table are measurements only. The gas valve should not be adjusted.

Table 2. Manifold and Gas Line Pressures