

Item No.:	_____	Qty.:	_____
Model No.:	_____		
Project No.:	_____		



## Standard Series Work Table

Standard Work Table, Backsplash with Stainless Steel Undershef

24"

30"

36"

- |                                       |                                       |                                       |
|---------------------------------------|---------------------------------------|---------------------------------------|
| <input type="checkbox"/> WT24S30-BSX  | <input type="checkbox"/> WT30S30-BSX  | <input type="checkbox"/> WT36S36-BSX  |
| <input type="checkbox"/> WT24S36-BSX  | <input type="checkbox"/> WT30S36-BSX  | <input type="checkbox"/> WT36S48-BSX  |
| <input type="checkbox"/> WT24S48-BSX  | <input type="checkbox"/> WT30S48-BSX  | <input type="checkbox"/> WT36S60-BSX  |
| <input type="checkbox"/> WT24S60-BSX  | <input type="checkbox"/> WT30S60-BSX  | <input type="checkbox"/> WT36S72-BSX  |
| <input type="checkbox"/> WT24S72-BSX  | <input type="checkbox"/> WT30S72-BSX  | <input type="checkbox"/> WT36S84-BSX  |
| <input type="checkbox"/> WT24S84-BSX  | <input type="checkbox"/> WT30S84-BSX  | <input type="checkbox"/> WT36S96-BSX  |
| <input type="checkbox"/> WT24S96-BSX  | <input type="checkbox"/> WT30S96-BSX  | <input type="checkbox"/> WT36S108-BSX |
| <input type="checkbox"/> WT24S108-BSX | <input type="checkbox"/> WT30S108-BSX | <input type="checkbox"/> WT36S120-BSX |
| <input type="checkbox"/> WT24S120-BSX | <input type="checkbox"/> WT30S120-BSX |                                       |

### Features

- 16 Gauge, 300 series stainless steel
- 4" backsplash with 1" return
- Welded construction for consistent metal gauge thickness throughout
- Sound deadened between top and bottom hat channels with double sided tape
- 1-5/8" Stainless steel legs and feet, adjustable up to 1"
- Fully adjustable stainless steel undershef
- Shipped knocked down for reduced shipping costs and supplied with Allen wrench and screws

### Options

- Custom Height (if less than 36")
- Cutout in Top (depending on size and location)
- Overshelves
- Undershelves
- Drawers
- Casters / Feet Upgrade

\* For additional available options, contact Elkay SSP

### Materials

- **Top:** 16 Gauge, 300 series stainless steel, 1-3/4" turned-down edge
- **Legs:** 1-5/8" Diameter heavy gauge stainless steel tubing with stainless steel leg gussets and stainless steel feet, adjustable up to 1"
- **Undershef:** 18 Gauge, 400 series stainless steel, 1-1/2" turned-down edge, fully adjustable

### Flyer Product



**AUTOQUOTES**



In keeping with our policy of continuing product improvement, Elkay SSP reserves the right to change product specifications without notice.

This specification describes an Elkay SSP product with design, quality and functional benefits to the user. When making a comparison of other producers' offerings, be certain these features are not overlooked.



Item No.: \_\_\_\_\_ Qty.: \_\_\_\_\_  
 Model No.: \_\_\_\_\_  
 Project No.: \_\_\_\_\_

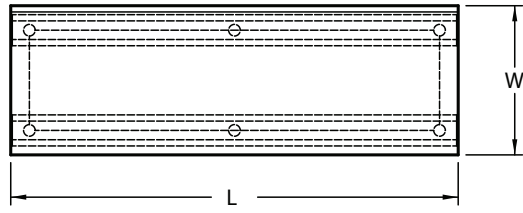

Size of Undershef:  
 Common length = subtract 6" from length  
 24" Width = subtract 6.5" from width  
 30" Width = subtract 7.45" from width  
 36" Width = subtract 10" from width

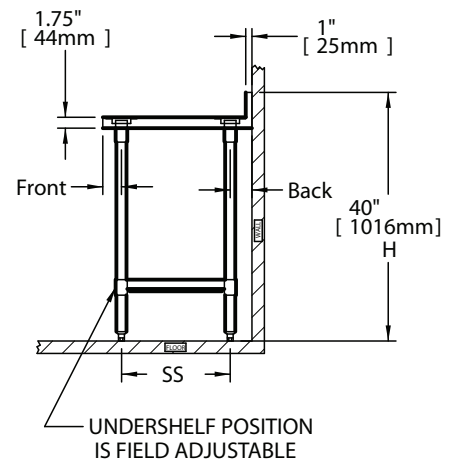
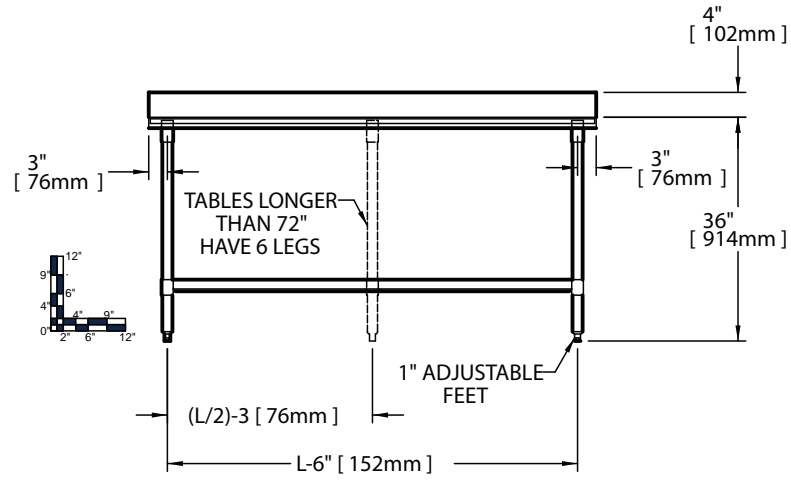

24" Work Table				30" Work Table				36" Work Table				Legs			
Model Number	Overall Size		Weight	Model Number	Overall Size		Weight	Model Number	Overall Size		Weight				
	Length L	Height H			Length L	Height H			Length L	Height H					
	in.	mm	lbs.   kg		in.	mm	lbs.   kg		in.	mm	lbs.   kg				
WT 24 S 30 - BS X	30	762	40   1016	91   41	WT 30 S 30 - BS X	30	762	40   1016	104   47				4		
WT 24 S 36 - BS X	36	914	40   1016	102   46	WT 30 S 36 - BS X	36	914	40   1016	114   52	WT 36 S 36 - BS X	36	914	40   1016	129   59	4
WT 24 S 48 - BS X	48	1219	40   1016	124   56	WT 30 S 48 - BS X	48	1219	40   1016	138   63	WT 36 S 48 - BS X	48	1219	40   1016	157   71	4
WT 24 S 60 - BS X	60	1524	40   1016	151   69	WT 30 S 60 - BS X	60	1524	40   1016	167   76	WT 36 S 60 - BS X	60	1524	40   1016	192   87	4
WT 24 S 72 - BS X	72	1829	40   1016	173   79	WT 30 S 72 - BS X	72	1829	40   1016	192   87	WT 36 S 72 - BS X	72	1829	40   1016	220   100	4
WT 24 S 84 - BS X	84	2134	40   1016	210   95	WT 30 S 84 - BS X	84	2134	40   1016	233   106	WT 36 S 84 - BS X	84	2134	40   1016	265   120	6
WT 24 S 96 - BS X	96	2438	40   1016	233   106	WT 30 S 96 - BS X	96	2438	40   1016	258   117	WT 36 S 96 - BS X	96	2438	40   1016	295   134	6
WT 24 S 108 - BS X	108	2743	40   1016	263   120	WT 30 S 108 - BS X	108	2743	40   1016	291   132	WT 36 S 108 - BS X	108	2743	40   1016	332   151	6
WT 24 S 120 - BS X	120	3048	40   1016	286   130	WT 30 S 120 - BS X	120	3048	40   1016	317   144	WT 36 S 120 - BS X	120	3048	40   1016	362   165	6

\* Custom sizes also available

