

Item No.:	_____	Qty.:	_____
Model No.:	_____		
Project No.:	_____		

## Standard Series Work Table

Standard Work Table, Flat Top with Stainless Steel Crossbracing



24"

30"

36"

- |  |  |  |
|--|--|--|
| <input type="checkbox"/> WT24X30-STSX  | <input type="checkbox"/> WT30X30-STSX  |  |
| <input type="checkbox"/> WT24X36-STSX  | <input type="checkbox"/> WT30X36-STSX  | <input type="checkbox"/> WT36X36-STSX  |
| <input type="checkbox"/> WT24X48-STSX  | <input type="checkbox"/> WT30X48-STSX  | <input type="checkbox"/> WT36X48-STSX  |
| <input type="checkbox"/> WT24X60-STSX  | <input type="checkbox"/> WT30X60-STSX  | <input type="checkbox"/> WT36X60-STSX  |
| <input type="checkbox"/> WT24X72-STSX  | <input type="checkbox"/> WT30X72-STSX  | <input type="checkbox"/> WT36X72-STSX  |
| <input type="checkbox"/> WT24X84-STSX  | <input type="checkbox"/> WT30X84-STSX  | <input type="checkbox"/> WT36X84-STSX  |
| <input type="checkbox"/> WT24X96-STSX  | <input type="checkbox"/> WT30X96-STSX  | <input type="checkbox"/> WT36X96-STSX  |
| <input type="checkbox"/> WT24X108-STSX | <input type="checkbox"/> WT30X108-STSX | <input type="checkbox"/> WT36X108-STSX |
| <input type="checkbox"/> WT24X120-STSX | <input type="checkbox"/> WT30X120-STSX | <input type="checkbox"/> WT36X120-STSX |

### Features

- 16 Gauge, 300 series stainless steel
- Welded construction for consistent metal gauge thickness throughout
- Sound deadened between top and bottom hat channels with double sided tape
- 1-5/8" Stainless steel legs and feet, adjustable up to 1"
- Adjustable stainless steel crossbracing
- Shipped knocked down for reduced shipping costs and supplied with Allen wrench and screw

### Options

- Custom Height (if less than 36")
- Cutout in Top (depending on size and location)
- Overshelves
- Undershelves
- Drawers
- Casters / Feet Upgrade

\* For additional available options, contact Elkay SSP

### Materials

- **Top:** 16 Gauge, 300 series stainless steel, 1-3/4" turned-down edge
- **Legs:** 1-5/8" Diameter heavy gauge stainless steel tubing with stainless steel leg gussets and stainless steel feet adjustable up to 1"
- **Crossbracing:** 1-1/4" Diameter, stainless steel, adjustable

### Flyer Product



**AUTOQUOTES**



In keeping with our policy of continuing product improvement, Elkay SSP reserves the right to change product specifications without notice.

This specification describes an Elkay SSP product with design, quality and functional benefits to the user. When making a comparison of other producers' offerings, be certain these features are not overlooked.



Item No.: \_\_\_\_\_ Qty.: \_\_\_\_\_  
 Model No.: \_\_\_\_\_  
 Project No.: \_\_\_\_\_

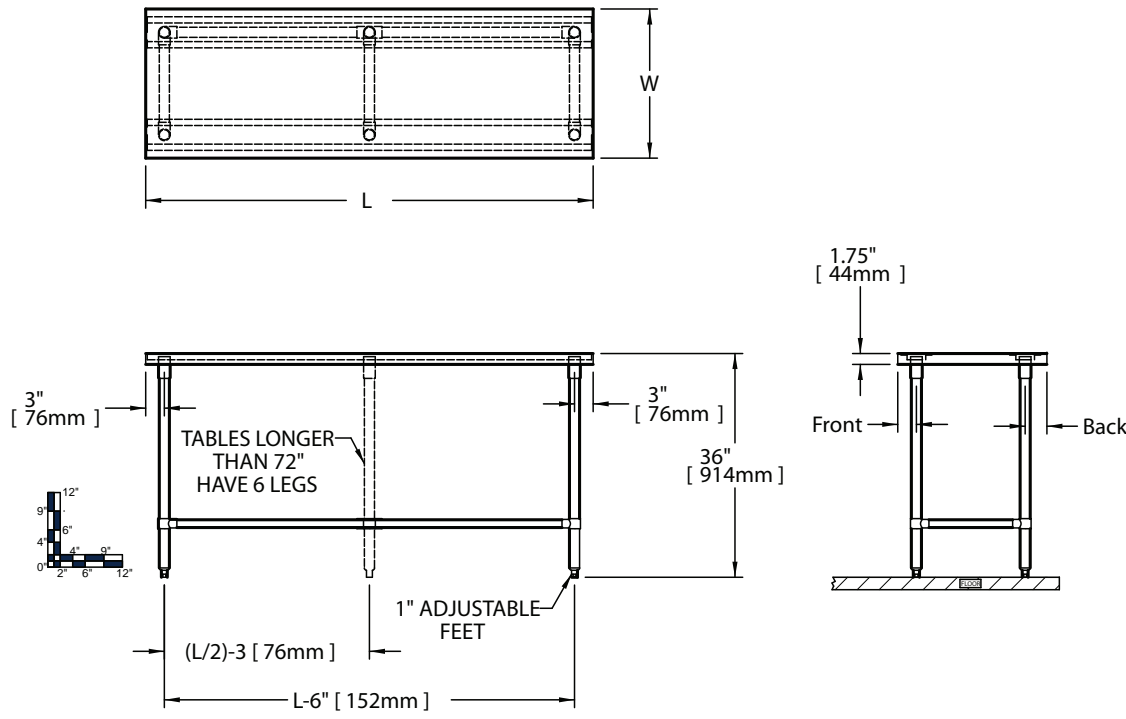

24" Work Table					30" Work Table					36" Work Table					Legs
Model Number	Overall Size		Weight		Model Number	Overall Size		Weight		Model Number	Overall Size		Weight		
	Length L	Height H	lbs.	kg		Length L	Height H	lbs.	kg		Length L	Height H	lbs.	kg	
WT 24 X 30 - STS X	30	36	76	35	WT 30 X 30 - STS X	30	36	86	39					4	
WT 24 X 36 - STS X	36	36	86	39	WT 30 X 36 - STS X	36	36	95	43	WT 36 X 36 - STS X	36	36	108	49	4
WT 24 X 48 - STS X	48	36	103	47	WT 30 X 48 - STS X	48	36	113	51	WT 36 X 48 - STS X	48	36	129	59	4
WT 24 X 60 - STS X	60	36	125	57	WT 30 X 60 - STS X	60	36	137	62	WT 36 X 60 - STS X	60	36	156	71	4
WT 24 X 72 - STS X	72	36	143	65	WT 30 X 72 - STS X	72	36	156	71	WT 36 X 72 - STS X	72	36	178	81	4
WT 24 X 84 - STS X	84	36	176	80	WT 30 X 84 - STS X	84	36	191	87	WT 36 X 84 - STS X	84	36	217	99	6
WT 24 X 96 - STS X	96	36	194	88	WT 30 X 96 - STS X	96	36	211	96	WT 36 X 96 - STS X	96	36	239	109	6
WT 24 X 108 - STS X	108	36	220	100	WT 30 X 108 - STS X	108	36	238	108	WT 36 X 108 - STS X	108	36	270	123	6
WT 24 X 120 - STS X	120	36	239	109	WT 30 X 120 - STS X	120	36	258	117	WT 36 X 120 - STS X	120	36	293	133	6

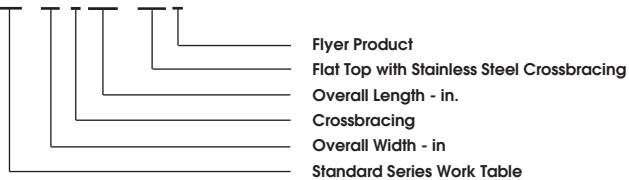

\* Custom sizes also available