

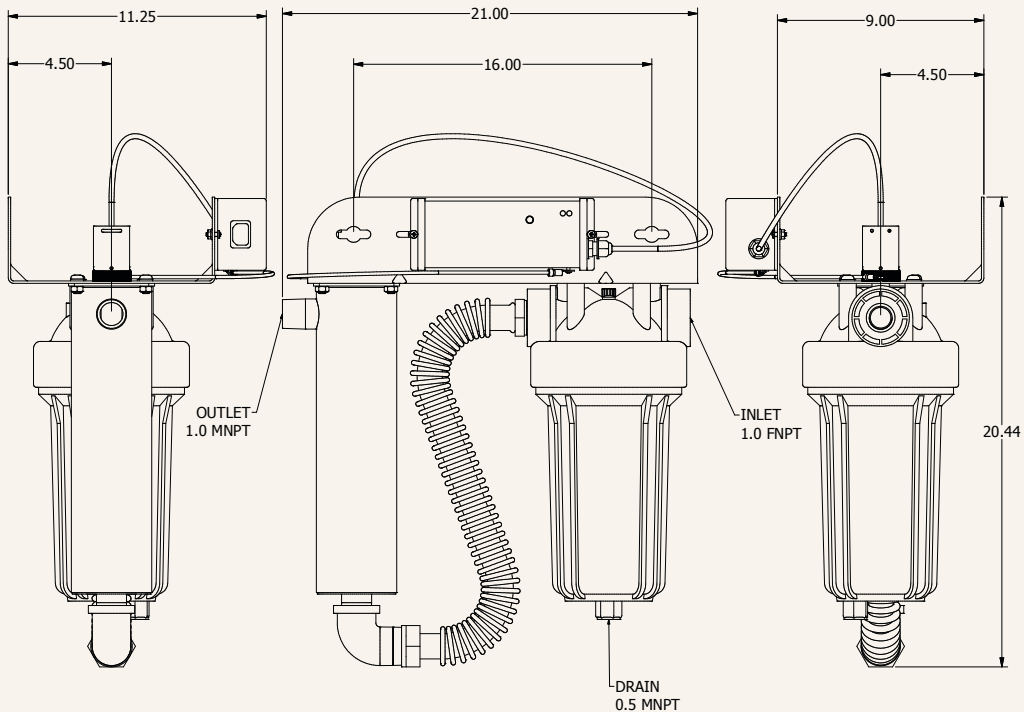

LANCASTER WATER TREATMENT

CLEAR-FLO HALO SHIELD ULTRAVIOLET PURIFIER

CLEAR-FLO HALO SHIELD ULTRAVIOLET LWT – WATER PURIFIER

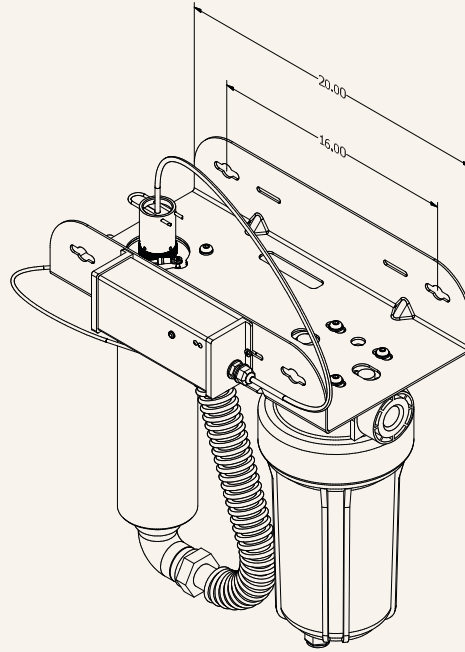

General notes for estimating only. All dimensions are in inches. Weight: 22 Lbs.

Note: Refer to Installation, Operating, and Service Manual for information regarding replacement components. To ensure system performance and warranty coverage, use proprietary Lancaster replacement components.



CLEAR-FLO HALO SHIELD ULTRAVIOLET PURIFIER

LWT-UV SPECIFICATIONS		ULTRAVIOLET WATER PURIFIER
Model Number	7-LWT-UV410-009	
Flowrate ⁽¹⁾	FLUENCE (UV DOSE)	
	US Public Health 16mJ/cm ²	17 GPM
	Industry Standard 30mJ/cm ²	9 GPM
Electrical	NSF/EPA 40mJ/cm ²	7 GPM
	Voltage ⁽²⁾	110 V to 240 V AC 50/60Hz
	Power Consumption	34 W
	Lamp Watts	29 W
Inlet/Outlet Port Size	1.0" FNPT Filter Housing Head Inlet / 1.0" MNPT UV Chamber Outlet	
Max/Min Operating Pressure	120 PSI / 7.25 PSI	
Pressure Drop at 30mJ/cm ² Rated Flow	Approx. 1.5 PSI (New 410-C5-MB Filter Cartridge) + Less than 1 PSI (UV Chamber) = Less than 3 PSI Total	
Ambient Air & Water Temperature	36 to 104°F	
Filter Cartridge Type	5 Micron Nominal, 4.50" OD x 10" Nominal Height, PP Melt-Blown Smooth with DOE	
Filter Housing Material	Reinforced PP Head and Blue Bowl, PP Vent Valve Body, EPDM O-Rings	
Lamp Type	Low Pressure High Output (LPHO)	
Chamber Material	304 SS	
Lamp-On Indicator	Steady "Work" Green LED	
Lamp Life Remaining (Days)	Visual Count Down Display (365 - 0); Manual Reset Function	
Lamp Replacement Reminder	Visual Display (A3) "Fault" Red LED Flashes and Audible Alarm Sounds Intermittently (1 Sec. Beep Every 5 Sec.)	
Lamp Replacement Reminder Delay	Silences Audible Alarm for 7 Days, Repeatable up to 4 Times (28 Days Maximum)	
Lamp Failure Indicator	Lamp Life Remaining (Days) Continues to be Displayed but Stops Counting Down Visual Display (LF) and "Fault" Red LED Flashes and Audible Alarm Sounds Intermittently (1 Sec. Beep Every 1 Sec.) or continuously	
Ballast Total Running Days	Visual Incremental Display (0 - 9999); Cannot Be Reset	
Ballast Failure Indicator	Blank Display	

⁽¹⁾ At flow rates stated, the corresponding fluence (UV dose) levels are theoretically met or exceeded at 95% UVT and EOL (end of lamp life; 1 year).

⁽²⁾ Models are supplied with a 5 FT. power cordset for 120V AC 60 Hz (NEMA 5-15P plug to IEC 60320/C13 connector).

Influent Limitations and Operating Parameters:

Water quality is extremely important for the optimum performance of your UV system. The following levels are recommended for installation:

- Iron: < 0.3 ppm (0.3 mg/L)
- Hardness*: < 7 gpg (120 mg/L)
- Turbidity: < 1 NTU
- Manganese: < 0.05 ppm (0.05 mg/L)
- Tannins: < 0.1 ppm (0.1 mg/L)

UV Transmittance: > 75% (call factory for recommendations on applications where UVT < 75%)

*Where total hardness is less than 7 gpg, the UV unit should operate efficiently provided the quartz sleeve is cleaned periodically. If total hardness exceeds 7 gpg, the water should be softened. If your water chemistry contains levels in excess of those mentioned above, proper pre-treatment is recommended to correct these water problems prior to the installation of your UV disinfection system. These water quality parameters can be tested by your local dealer, or by most private analytical laboratories. **Proper pre-treatment is essential for the UV disinfection system to operate as intended.**