



EASE OF INSTALLATION AND SERVICEABILITY

- Compact Design to Save Space
- Wi-Fi Technology for Remote Monitoring, Management and Recirculation Control.
- Improved Gas Conversion

OPTIONAL ACCESSORIES

Condensate Neutralizer, ScaleCutter, Additional Controllers, Pipe Cover, EZConnect™ Cables, control•r™ Wi-Fi Module, External Recirculation Pump, Wireless Accessories, and many more.

Visit rinnai.us for a complete list of accessories.

HIGH-EFFICIENCY (NON-CONDENSING) TANKLESS WATER HEATER

Installation Type	Internal (Indoor) Residential Applications. Manufactured (Mobile) Home Certified	
Model Numbers	RE199i (REU-VE2737FFD-US) RE180i (REU-VE2432FFD-US) RE160i (REU-VE2125FFD-US) RE140i (REU-VE1720FFD-US)	
Approved Gas Types	Natural and Propane	
Efficiency		UEF: 0.82 (RE199i, RE180i) 0.81 (RE160i, RE140i)
High Altitude Approved	Up to 10,200 ft (3,109 m)	
Water Flow Control	Water Flow Sensor, Electronic Water Control and Bypass Control (RE199/RE180 only)	
Controller	Standard: Integrated Controller Optional: MC-195T-US, RWM101 (control•r™), MCC601, MCC601 (RE199/RE180)	
Certifications	AHRI, ANSI Z21.10.3, CSA 4.3	

Warranty

- Heat Exchanger: 15 years or 12,000 operation hours, whichever occurs first
- All Other Parts and Components: 5 Years
- Reasonable Labor: 1 Year

Safety Devices

Flame Failure - Flame Rod, Boiling Protection, Combustion Fan RPM Check, Over Current - Glass Fuse, Remaining Flame (OHS) and Automatic Frost Protection

Additional Features

- Mobile Home Certified
- Complies with South Coast Air Quality Management District 14 ng/J or 20 ppm NOx Emission Levels
- Ultra Low NOx



CERTIFIED TO ANSI Z21.10.3 — CSA 4.3

TECHNICAL SPECIFICATIONS

SPECIFICATION		RE199i	RE180i	RE160i	RE140i
Dimensions - w, h, d		14.05 in. x 27.3 in. x 11.2 in. (357 mm x 693 mm x 284 mm)			
Minimum Gas Consumption Btu/h		10,400			
Maximum Gas Consumption Btu/h		199,000	180,000	160,000	140,000
Flow Rate ¹ (Min - Max)		0.13 - 9.8 GPM (0.5 - 37 L/min)	0.13 - 8.5 GPM (0.5 - 32 L/min)	0.26 - 6.6 GPM (1.0 - 25 L/min)	0.26 - 5.3 GPM (1.0 - 20 L/min)
Max Flow Rate with Parameter Adjustment		9.8 GPM (37 L/min)	8.5 GPM (32 L/min)	6.6 GPM (25 L/min)	5.3 GPM (20 L/min)
Activation Flow Rate		0.4 GPM (1.5 L/min) ²		0.4 GPM (1.5 L/min)	
Weight		42.1 lb (19.1 kg)		38.5 lb (17.5 kg)	
Sound Level		54 dB			
Electrical	Normal	96 W	87 W	91 W	71 W
	Standby	1 W			
	Freeze Protection	86 W			
	Max Current	4 Amps			
	Fuse	10 Amps			
Temperature		98°F-140°F (37°C-60°C)		120°F-140°F (49°C-60°C)	
By-Pass Flow Control		Bypass Servo Control		Fixed Bypass	
Gas Supply Pressure ³		<ul style="list-style-type: none"> Natural: 4.0 in. w.c. - 10.5 in. w.c. Propane: 8.0 in. w.c. - 13.0 in. w.c. 			
Ignition System		Direct Electronic Ignition			
Electronic Connections		<ul style="list-style-type: none"> Appliance: AC 120 Volts, 60Hz. 			
Water Supply Pressure		<ul style="list-style-type: none"> Minimum: 20 PSI (Recommended 30-80 PSI for max performance) Maximum: 150 PSI 			
Service Connections		<ul style="list-style-type: none"> Gas Supply: 3/4 in. (19 mm) NPT Cold Water Inlet: 3/4 in. (19 mm) NPT Hot Water Outlet: 3/4 in. (19 mm) NPT 			
Clearances		<ul style="list-style-type: none"> Top: 2 in. (51 mm)* Bottom/Ground: 12 in. (305 mm) Front: 0 in.** 		<ul style="list-style-type: none"> Back: 0 in. Sides: 2 in. (51 mm) Vent: 0 in. 	

* 0 in. from vent components

** Clearance for servicing is 24 in. (610 mm) in front of water heater

¹Minimum flow may vary slightly depending on the temperature setting and the inlet water temperature.

²Minimum activation flow is 0.4 GPM (1.5 L/min).

³0.26 GPM activation at set temperature of ≥140°F.

³The maximum gas supply pressure must not exceed the specified value.

WATER FLOW CURVE

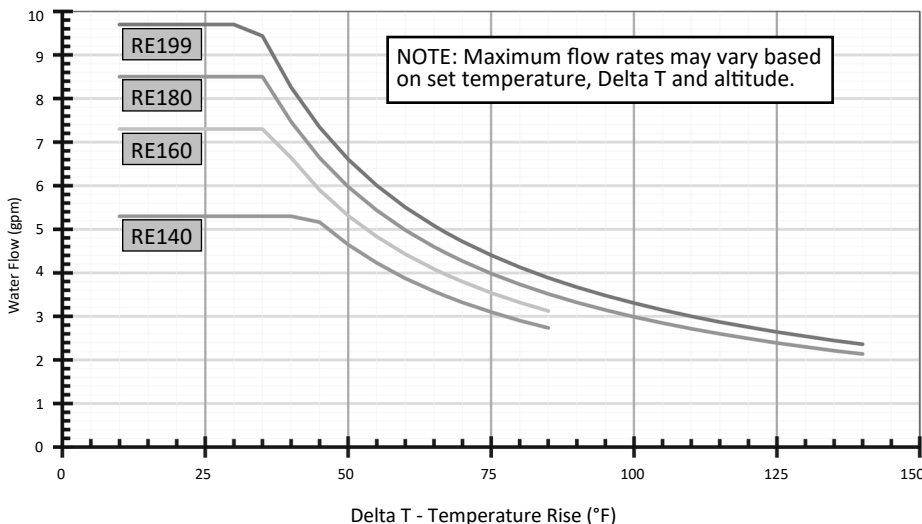

DIMENSIONS

in. (mm)

FRONT

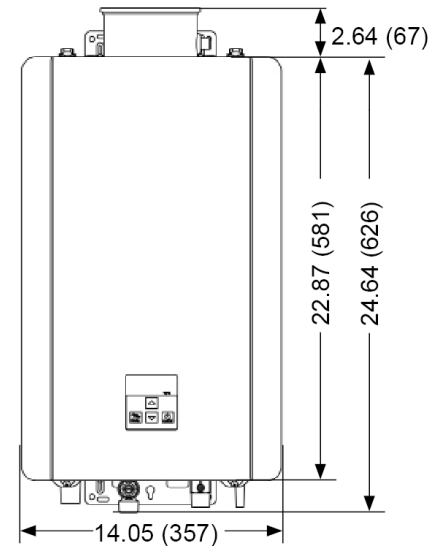

SIDE

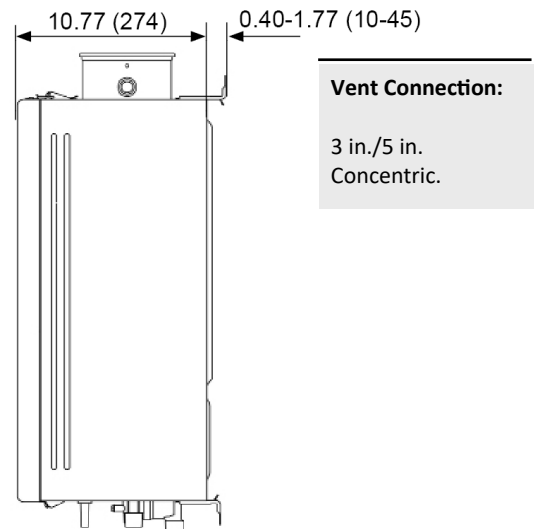

BOTTOM

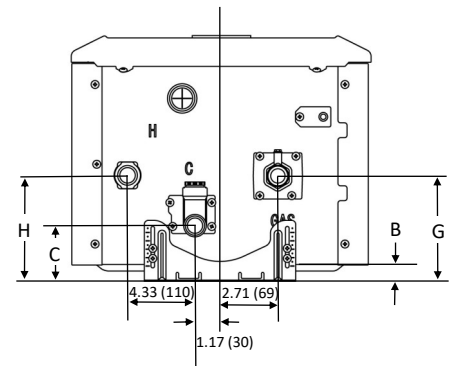

Connection		in.*	mm*	in.**	mm**
COLD	C	2.24	57	3.46	88
HOT	H	4.6	117	5.82	148
GAS	G	4.57	116	5.79	147
Bracket	B	.40	10	1.6	41

*Wall bracket retracted.

**Wall bracket extended.