

INSTALLATION INSTRUCTIONS

Low Global Warming Potential (GWP) Refrigerant Detection System (RDS) Communicating Control Board (RDS Field Kit - Communicating)

This manual must be left with the owner for future reference.

Contents

Certifications.....	3	Additional Applications.....	14
Shipping and Packing List.....	3	<i>Zone HVAC System</i>	14
Overview.....	3	<i>External Alarm</i>	14
Operating Environment Specifications.....	3	Start Up Test Procedure.....	15
Product Features.....	3	<i>Cooling Demand</i>	15
Introduction.....	4	<i>Heating Demand</i>	15
RDS Blower Control Board Dimensions.....	5	Wiring Diagrams.....	16
Installation.....	6	<i>Communicating Thermostat with Indoor and Outdoor Units</i>	16
<i>Sensor Part Number Verification</i>	6	<i>Communicating Indoor Controls and Float Switch</i>	17
<i>Mounting Methods</i>	6	<i>Communicating Thermostat, Communicating Furnace with EIM, and Two-Stage Heat Pump</i>	18
<i>Mounting Location</i>	6	<i>Communicating Thermostat, Communicating Two-Stage Furnace with EIM, and Communicating Outdoor Unit</i>	19
<i>Routing the Sensor Cable</i>	8	<i>Communicating Two-Stage Furnace & Non- Communicating Two-Stage Unit</i>	20
<i>Connecting the RDS Sensor</i>	9	<i>Communicating Zoning with Communicating Thermo- stat, Indoor, and Outdoor Units</i>	21
DIP Switch Settings.....	10	Diagnostic Codes and Troubleshooting.....	22
Modes of Operation.....	10		
<i>Initializing</i>	10		
<i>Normal</i>	10		
<i>Leak Detected</i>	10		
<i>Fault</i>	11		
Diagnostic Codes.....	11		
<i>Red LED Diagnostic Codes</i>	11		
Test Button Functionality.....	12		
<i>Test Button - Additional Functions</i>	13		
Thermostat Compatibility.....	13		
<i>Compatibility Verification</i>	14		



(P) 508639-01

⚠WARNING

Improper installation, adjustment, alteration, service or maintenance can cause property damage, personal injury or loss of life.

Installation and service must be performed by a licensed professional HVAC installer (or equivalent) or a service agency.

⚠WARNING

All systems charged with at least 4 lbs of low-GWP refrigerant are required to have a refrigerant leak detection system installed to prevent the build up of A2L refrigerant in enclosed spaces of the HVAC equipment. A refrigerant detection system may be required for systems that have less than 4 lbs of low-GWP refrigerant. For more information on this, contact Technical Support.

Installing a residential HVAC system with A2L-classified refrigerant without a refrigerant detection system may lead to a fire hazard within the home in the event of a refrigerant leak.

⚠WARNING

The OEM RDS Blower Control Board has been tested with OEM coils only. Do not use a non-OEM refrigerant detection system controller or non-OEM leak sensor with OEM coils. Do not use this RDS Blower Control Board with non-OEM coils or air handlers.

⚠WARNING

Improper installation of the RDS Blower Control Board may lead to unreliable equipment operation and and unreliable refrigerant detection.

In addition to installing the RDS Blower Control Board, considerations must be made regarding sensor mounting location. Please refer to respective air handler, coil, and/or sensor kit installation guides for further details.

⚠CAUTION

Any service personnel installing, decommissioning, or performing maintenance on the unit. It is the responsibility of the licensed installer or service agency to obtain the appropriate training and/or certifications to work on A2L-classified HVAC systems with low GWP refrigerants.

⚠CAUTION

Unit must remain powered except for service.

Certifications

- CSA C22.2 No. 60335-2-40:22; Fourth ed.
- UL 60335-2-40; Fourth ed.

Shipping and Packing List

Qty	Description	Cat. No.
1	Communicating Low GWP Refrigerant Detection System Kit	27A06
2	Mounting Hardware - #6-18 1" Phillips Drive pan head with dry wall anchor	N/A

NOTE: *This kit is sold separately from the refrigerant detection sensor. The refrigerant sensor is included as part of the sensor kit, R-454B-only coil, or R454B-only air handler.*

Overview

Low GWP Refrigerant Detection System, ensures nominal operation of OEM residential HVAC systems equipped with A2L-classified refrigerant low GWP refrigerant. The RDS Blower Control Board connects to the refrigerant detection sensor, the indoor unit, the outdoor unit and the thermostat to control the HVAC system in the event in the event refrigerant is detected by the sensor. The RDS Blower Control Board functions with standard 24VAC or OEM-communicating control interfaces.

Operating Environment Specifications

The Low GWP Refrigerant Detection Kit is designed to withstand the following conditions:

Condition	Temperature Range
Normal Operation	-40°F - 185°F
Shipping/Storage	(40°C - 85°C)
	Functional Range
Humidity	10% to 90% non-condensing at 104°F (40°C)

Product Features

- Detects R-454B refrigerant leaks and helps to prevent a concentration of refrigerant from reaching the lower flammability limit, should a leak occur in the indoor coil.
- Multicolor LED (light-emitting diode) communicates RDS Blower Control Board state
- Test/Reset button (to verify RDS Blower Control Board functionality)
- Composite case with mounting hardware for drywall installation.
- Supports up to two refrigerant detection sensors
- Supports standard 24VAC control split HVAC equipment (Single-Stage, Two-Stage, Variable Speed, Heat Pump, AC, Gas Furnace, Air Handler) See "Thermostat Compatibility" on page 13.
- Compliant with UL-60355-2-40 & CSA
- Compatible with OEM approved sensor
- Required when installing an OEM outdoor unit that use R-454B refrigerant. Some indoor units may already feature a refrigerant detection control functionality and may not require this kit. Contact Technical Support for more information.

Introduction

The OEM Low GWP Refrigerant Detection System ensures safe operation of OEM residential HVAC systems equipped with low GWP refrigerant (R-454B).

The RDS Blower Control Board activates the blower in the event the refrigerant concentration in the cabinet begins to rise. The control will activate the blower if the concentration reach 12% of the lower flammability limit (LFL) whereas the UL standard is 20% of the LFL. Power to ignition sources is also interrupted. The refrigerant concentration in the cabinet and interrupts power to ignition sources in the HVAC system when it detects a refrigerant leak in the indoor coil.

After refrigerant concentrations have been reduced to safe levels, the RDS Blower Control Board allows the HVAC system to resume normal functionality. The HVAC system will operate normally if the RDS Blower Control Board is functioning.

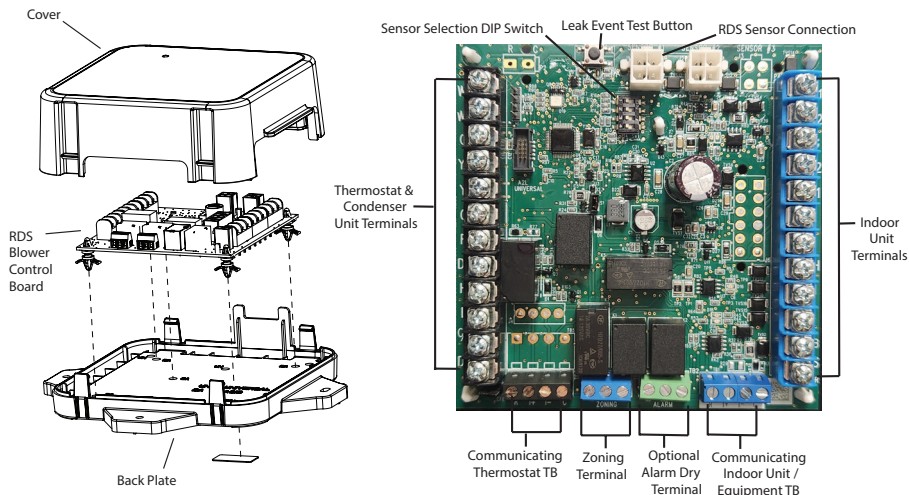

Figure 1. RDS Non-Communicating Blower Control Board

RDS Blower Control Board Dimensions

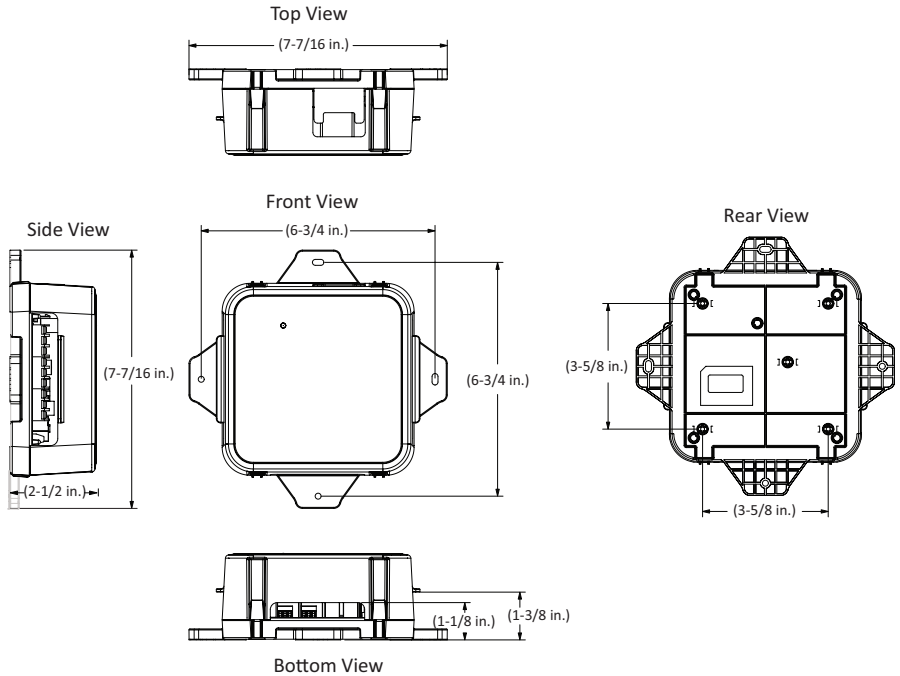

Figure 2. RDS Blower Control Board - Dimensions

Installation

Sensor Part Number Verification

Verify the refrigerant detection system sensor's part number, which is found on the sensor/cable, prior to installation. The part number is 107648-01.

NOTE: *All sensors paired to a single RDS Blower Control Board **must share the same part number** (107648-01) to ensure the RDS Blower Control Board will function properly.*

Mounting Methods

Some mounting surfaces may be difficult to access after the RDS Blower Control Board is installed. OEM suggests wiring the RDS Blower Control Board unit prior to mounting in a confined space.

For drywall/closet installations, use the included drywall hardware. For attic/crawl-space/basement installations, use the included and field-provided hardware.

Mounting Location

The RDS Blower Control Board can be mounted to the indoor unit, plenum, a stud, or joist in an attic, crawlspace, or other unfinished area within 48 inches of the refrigerant sensor cable grommet on the coil or air handler. Drywall anchors and screws are provided for installation in finished areas, such as closets. Mount the RDS Blower Control Board in a clean, dry en-

vironment that is away from dust, water, and other contaminant accumulation.

NOTE: *Mounting the RDS Blower Control Board farther than 48 inches away from the refrigerant sensor may prevent reliable operation due to cable strain and water seepage on cable connections.*

- **Do not** place the RDS Blower Control Board in secondary drain pan
- Use the screws provided to mount the RDS Blower Control Board
- Tighten the screws to a snug fit

NOTE: *Do not over-tighten the screws. Over-tightening the screws may strip the hardware and apply excessive stress on the enclosure.*

Refrigerant Detection System Sensor

The refrigerant detection system sensor must be mounted as specified in its accompanying manual. Mounting the sensor incorrectly or in an improper location may result in refrigerant detection failure.

Condensate Safety Switch (Float Switch)

COMMUNICATING APPLICATIONS

In applications that require a condensate safety switch (float switch), a (field-provided) isolation relay must be installed with the float switch. The relay NO (normally open) contacts must be wired between "R" and "DS" at the

indoor unit control board and the (W914) jumper must be cut. See “Communicating Indoor Controls and Float Switch” on page 16. Do not wire the condensate safety switch or any other field installed safety switches between the indoor unit transformer and the RDS Blower Control Board. The RDS Blower control board must remain powered at all times.

NON-COMMUNICATING APPLICATIONS

In applications that require a condensate safety switch (float switch) the float switch must be wired between the room thermostat and the Refrigerant Detection System. The float switch's normally closed contacts may be wired to interrupt the “R” wire or the “Y” wire between the thermostat and the RDS Blower Control Board. See the Blower Control Board wiring diagrams. This ensures the Blower Control Board is powered continuously and operates normally. Do not wire the condensate safety switch or any other field installed safety switches between the indoor unit transformer and the RDS Blower Control Board. The RDS Blower control board must remain powered at all times.

Refrigerant Detection System Sensors

The OEM Refrigerant Detection System requires an OEM RDS coil sensor located in the indoor coil. See table below.

Indoor Unit Model	RDS Blower Control Board Sensor Catalog Number	Description
<ul style="list-style-type: none"> • 7ECX Upflow • 7EHX Horizontal • 7EDX Downflow "Revision 01" Coils 	26Z69	Coil Sensor Kit
All OEM R-454B Coils & Air Handlers	27V53	Coil Sensor Repair Kit (Replacement Sensor only, without mounting bracket & components provided in the Sensor Kit)

Routing the Sensor Cable

Figure 3 illustrates how to best route the sensor cable from the RDS Blower Control Board to the sensor within the indoor unit for the Upflow, Downflow, and Horizontal orientations. For details on mounting the sensor itself, refer to the respective sensor kit, air handler, or coil installation guide.

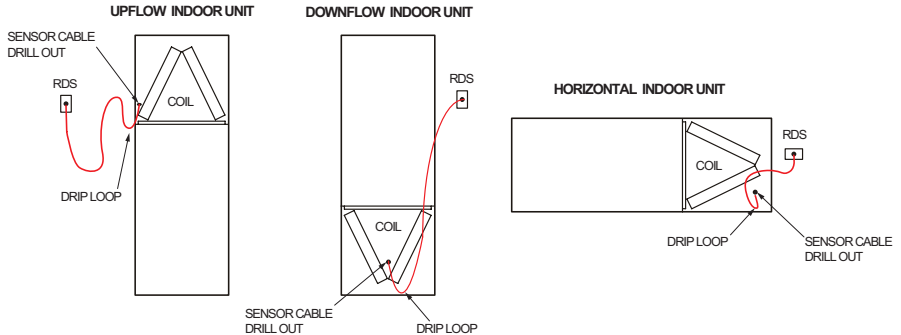

Figure 3. Routing the Sensor Cable

⚠WARNING

Do not strap the RDS Blower Control Board to existing tubing or other electrical cables.

Connecting the RDS Sensor

Ensure the cable is properly seated into the SENSOR 1 plug. The Molex plug clip should lock into the Molex connection point for a secured connection, as shown below in Figure 4. Verify the connection is free of dust, debris, and moisture.

NOTE: *In confined space applications, connect the second sensor to the SENSOR 2 plug.*

Molex Plug Clip

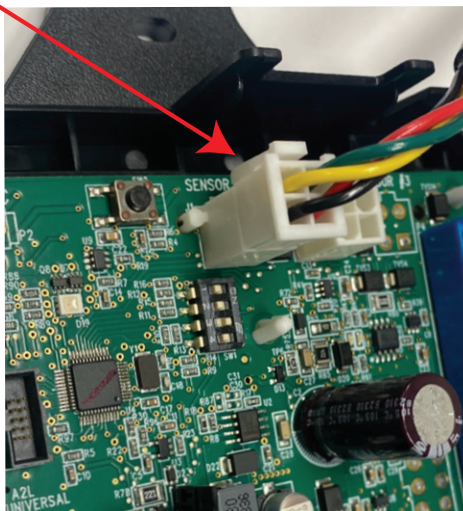

Figure 4. Connecting the RDS Sensor to RDS Blower Control Board

DIP Switch Settings

Adjust the DIP switch settings to the sensor configuration. Failure to do so will cause faults on power-up.

Table 1. DIP Switch Settings

Configuration	Switch 1	Switch 2	Switch 3	Switch 4
One (1) sensor, connected to SENSOR 1 plug	OFF	ON	N/A	N/A
Two (2) sensors, connected to SENSOR 1 plug and SENSOR 2 plug	OFF	OFF	N/A	N/A

In single sensor configurations, the sensor must be connected to the SENSOR 1 plug. Configurations other than the ones shown in Table 1 will cause a service fault.

Each DIP switch corresponds to a sensor position (i.e., DIP switch 1 to sensor 1; DIP switch 2 to sensor 2). The default factory switch positions are set to OFF. The RDS Blower Control Board software reads the OFF position as an active sensor. A sensor should be present for the corresponding sensor connector. Setting the DIP switch to ON disables the sensor position.

NOTE: *Refer to 508467-01 (Installation Instructions for Refrigerant Leak Detection Sensor Kit - Indoor Coils) to determine whether more than one (1) Refrigerant Leak Detector Sensor is required.*

Modes of Operation

The modes of operation for the RDS Blower Control Board are Initializing, Normal, Refrigerant Detected, and Fault.

Initializing

The RDS Blower Control Board is establishing connection with the refrigerant detection sensor and is completing an initial five (5) minute purge sequence.

Normal

The HVAC system is functioning normally. The RDS Blower Control Board has not detected a refrigerant leak.

Refrigerant Detected

When the RDS Blower Control Board detects a refrigerant leak:

1. **Communicating System Applications:**
The RDS Blower Control Board communicates to the communicating thermostat and the communicating thermostat will de-energize the outdoor unit compressor and heat sources, such as gas and/or electric strip heat. No heating or cooling demands will be met. The communicating thermostat will display a E150 "A leak of refrigerant has been detected by the refrigerant detection system"
Non-Communicating System Applications:
The RDS Blower Control Board shuts off the (R) input (24VAC power) to the thermostat, which de-energizes

the outdoor unit compressor and heat sources, such as gas and/or electric strip heat. No heating or cooling demands will be met.

2. The RDS Blower Control Board activates the blower (high speed). The blower purges refrigerant from the cabinet, plenum, and ductwork.
3. After the RDS Blower Control Board determines the refrigerant levels are below the safety threshold, the blower will continue to operate for the remainder of the seven(7) -minute cycle.
4. After the blower sequence is complete, the HVAC system resumes normal operation.

NOTE: *The HVAC system may not maintain a cooling or heating setpoint if a significant leak exists. Any refrigerant leaks that remain unaddressed for an extended time may cause the HVAC system to shut down on a low refrigerant pressure limit condition.*

Fault

When a fault is detected within the RDS Blower Control Board, the indoor unit blower engages and remains engaged at a constant output until the fault is cleared.

Diagnostic Codes

The RDS Blower Control Board is equipped with a multicolor LED within its enclosure. The

LED signals the state of the RDS Blower Control Board.

See Table 2 to review the diagnostic codes.

Table 2. LED Diagnostic Codes

State	LED Diagnostic Code	Action
Initializing	Flashing green ¹	Not Applicable
Monitoring	Solid green with blue flash ²	Not Applicable
Mitigating (Refrigerant Detected)	Flashing blue	Check coil tubes for leak. Repair the issue and restart the equipment.
Fault/Service	Solid blue, interrupted by issue flash code	Refer to Table 7 for troubleshooting steps.

1. A rapid flash indicates the RDS Blower Control Board is in the process of sensor enumeration

2. A blue flash indicates the mitigation process has previously occurred.

Red LED Diagnostic Codes

Red diagnostic codes indicate a specific RDS Blower Control Board issue. Yellow diagnostic codes indicate the sensor's position (if applicable).

Table 3. Red LED Diagnostic Codes

Red Flash	Applies to Individual Sensor(s)	Issue	Action
1	Yes	Sensor indicates fault	Replace the sensor (Cat. # 27V53)
2	No	Spare Code - Unused	Not Applicable
3	Yes	Incompatible sensor type	Replace with a compatible sensor (Cat. # 26Z69)
4	Yes	Sensor communications issue	Check sensor connection. Ensure connection is clean and tight.
5	No	R-input not available	Check for 24VAC power connection to the R terminal inputs on the RDS Blower Control Board. R-inputs must be energized for the RDS Blower Control Board to function.
6	No	Invalid configuration of sensor count	Verify the DIP switch setting is correct and matches the number of sensors being used.

Test Button Functionality

The RDS Blower Control Board is equipped with a Test/Reset button. The Test button can be used to complete several functions, depending on the mode of operation of the RDS Blower Control Board.

Table 4 lists the functions of the Test button during each mode of operation.

Table 4. Test Button Function

Mode of Operation	Press the Test Button to...
Normal	Trigger a refrigerant detection response. Verify all equipment is wired correctly into the RDS Blower Control Board (after installation).
Refrigerant Detected	Reset the RDS Blower Control Board to a normal mode of operation after refrigerant has been detected and purged from the HVAC system.
Fault	Reset the RDS Blower Control Board after troubleshooting and resolving a fault condition. If the fault is not resolved, the RDS Blower Control Board will enter the Fault mode again.

Test Button - Additional Functions

Table 5 lists the additional functions of the Test Button while the RDS Blower Control Board is functioning within the states of Initializing, Monitoring, Refrigerant Detection, Servicing and Fault. Refer to “Table 2. LED Diagnostic Codes” on page 11.

Table 5. Additional Button Functions

State	Press	Action
Initializing	Short	Skips remaining pre-purge after sensors are recognized by the RDS Blower Control Board
Initializing	Long	Reset control
Monitoring	Short	Clear purge-counter if prior mitigation has occurred; Test mitigation
Monitoring	Long	Reset control
Mitigating	Short	If testing mitigation, end test
Servicing	Short	Reevaluate fault condition - if cleared return to monitoring, otherwise update indicator
Servicing	Long	Reset control
Fault	Short	Reevaluate fault condition - if cleared return to monitoring, otherwise update indicator
Fault	Long	Reset control

Thermostat Compatibility

Thermostats that preserve memory settings are compatible with the RDS Blower Control Board. Examples include:

- Battery-powered thermostats
- Analog thermostats
- Smart thermostats
- OEM communicating thermostats (A3)
- Late-model programmable thermostats

NOTE: *Early-generation digital and programmable thermostats may not retain the operation mode and temperature setpoints after a power outage.*

The following scenarios are likely to occur when home occupants are not available to adjust the thermostat setpoints as the system is recovering from refrigerant detection and resuming normal operation:

- Heating could be lost during a cold night
- Cooling could be lost during a hot day
- The thermostat could reset to an incorrect temperature setpoint

Compatibility Verification

Complete the following process to determine whether the thermostat is compatible with the RDS Blower Control Board.

1. Change the thermostat's current setpoint and operating mode.
2. Power cycle the breaker to the furnace.

NOTE: *Wait five (5) minutes before supplying power to the furnace breaker.*

3. Note whether the thermostat maintained its setpoints and operating mode.
 - a. If the thermostat maintained the settings, the thermostat is compatible with the RDS Blower Control Board.
 - b. If the thermostat did not maintain its setpoint and/or operating mode, the thermostat is not compatible with the RDS Blower Control Board. Recommend a compatible thermostat.

Additional Applications

In zoned applications, all dampers will remain open when the RDS Blower Control Board is in Fault or Refrigerant Detected mode. Normal heating and cooling demands are permissible, but the blower will remain engaged until the fault condition is addressed.

Zone HVAC System

If the RDS Blower Control Board is installed in a zone HVAC system, the RDS Blower Control Board will open all zone dampers if refrigerant is detected.

NOTE: *Proper wiring of the zone panel to the RDS Blower Control Board is required for all zone dampers to open.*

After the purge sequence is complete, the zone system will resume normal operation.

External Alarm

(For applications with external alarms wired directly to the RDS Blower Control Board.)

The RDS Blower Control Board triggers the external alarm system when it enters refrigerant Detected mode. For alarm notifications, the RDS Blower Control Board provides a dry relay contact that is rated 3A at 30 VAC/DC.

Start Up Test Procedure

The RDS Blower Control Board is equipped with a Test/Reset button, see “Test Button Functionality” on page 12. “After the RDS Blower Control Board has been mounted and wired, restore power to the HVAC system. The system will then run through a purge sequence for five (5) minutes. After the purge sequence is complete, proceed to testing cooling demand and heating demand.

Cooling Demand

1. Prompt a cooling demand at the thermostat.
2. Press the Test button on the RDS Blower Control Board.
The system then executes a refrigerant detection response.
3. Observe the following sequence:
 - a. The LED indicator flashes the sequence for leak detection (flashing blue).
 - b. The blower powers up.
 - c. The outdoor compressor powers down.
4. Press the Test button to terminate the simulated Refrigerant Detected mode upon test completion.

Heating Demand

1. Prompt a heating demand at the thermostat.
2. Observe the following sequence:
 - a. The LED indicator flashes the sequence for refrigerant detection (flashing blue).
 - b. The blower powers up.
 - c. The gas burners power down.
 - d. The outdoor compressor powers down.
3. Press the Test button to terminate the simulated Refrigerant Detected mode upon test completion.

The installation of the RDS Blower Control Board is complete after both sequences are successfully completed.

Wiring Diagrams

OEM provides wires designated for wiring the sensor cable. Wires required for the RDS installation is field supplied.

The RDS supports OEM and non-OEM split gas furnace installations. Wiring diagrams are provided for several common split furnace system configurations to identify exact wire types and terminal locations.

Communicating Indoor Controls and Float Switch

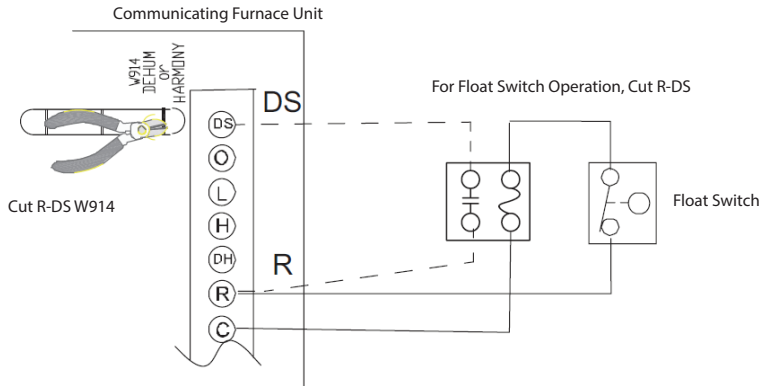

Communicating Thermostat with Indoor and Outdoor Units

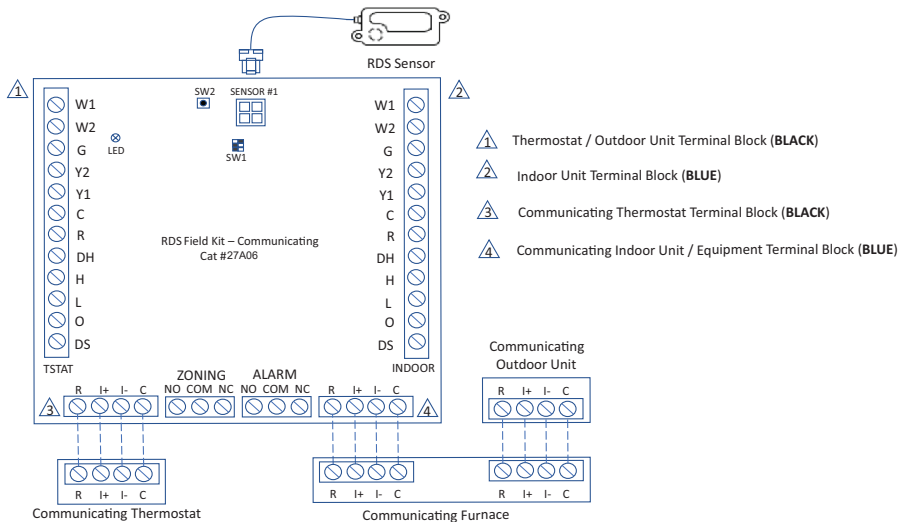

Communicating Thermostat, Communicating Furnace with EIM, and Two-Stage Heat Pump

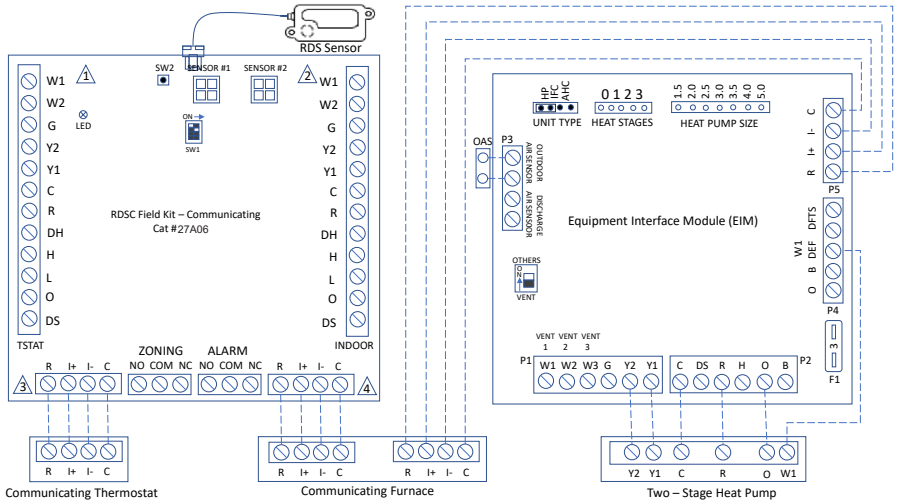

Communicating Thermostat, Non-Communicating Two-Stage Furnace with EIM, and Communicating Outdoor Unit

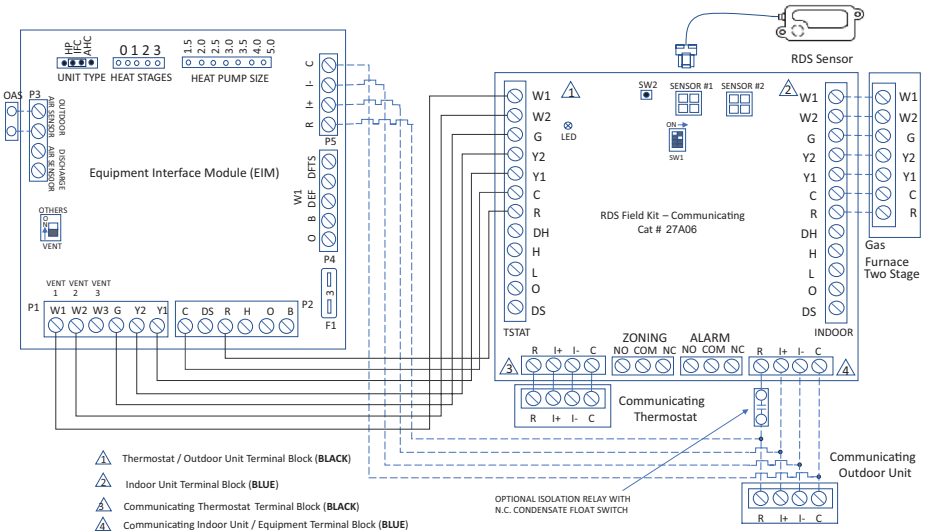

Communicating Two-Stage Furnace & Non-Communicating Two-Stage Unit

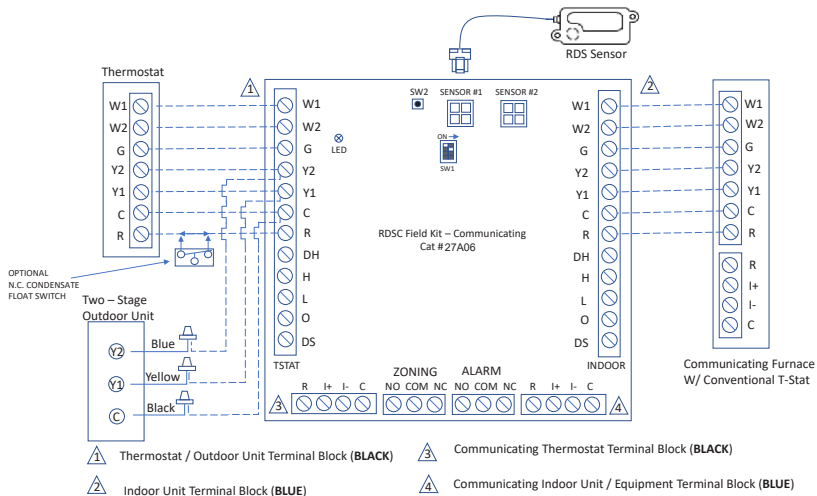

Communicating Zoning with Communicating Thermostat, Indoor, and Outdoor Units

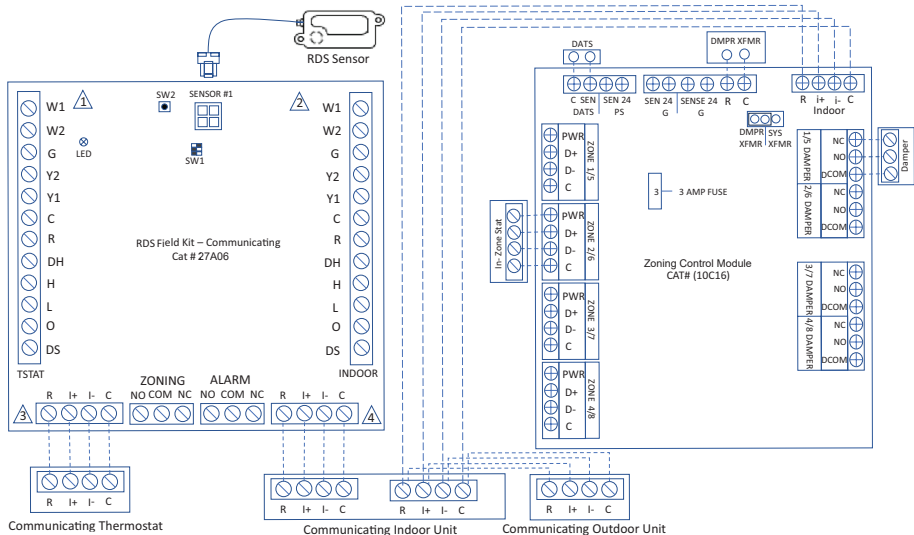

⚠ Thermostat / Outdoor Unit Terminal Block (BLACK)

⚠ Indoor Unit Terminal Block (BLUE)

⚠ Communicating Thermostat Terminal Block (BLACK)

⚠ Communicating Indoor Unit / Equipment Terminal Block (BLUE)

Diagnostic Codes and Troubleshooting

Table 6. LED Diagnostic Codes

State	LED Diagnostic Code	Action Required
Initializing	Flashing green	None
Monitoring	Solid green. If a prior mitigation occurred, a blue flash interrupts the solid green LED.	None
Mitigating (Leak Detected)	Flashing blue	Check coil tubes for leak. Repair the issue and restart the equipment.
Fault/Service	Solid blue, interrupted by issue diagnostic code	Refer to Table 7 for troubleshooting steps.

Table 7. Red LED Diagnostic Codes / Troubleshooting

Red Flash	Applies to Individual Sensor(s)	Issue	Action Required
1	Yes	Sensor indicates fault	Replace the sensor (Cat. # 27V53)
2	No	Spare Code - Unused	Not Applicable
3	Yes	Incompatible sensor type	Replace the sensor (Cat. # 26Z69)
4	Yes	Sensor communications issue	Check sensor connection. Ensure connection is clean and tight.
5	No	R-input not available	Check sensor connections. Ensure connection is clean and tight.
6	No	Invalid configuration of sensor count	Verify the DIP switch setting is correct and matches the number of sensors being used.