

## PRODUCT SUBMITTAL 920

Product: SDR11 Straight Tees

Date: 01 January 2018 (supersedes 01 January 2017)

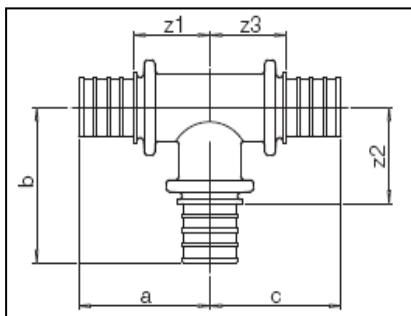
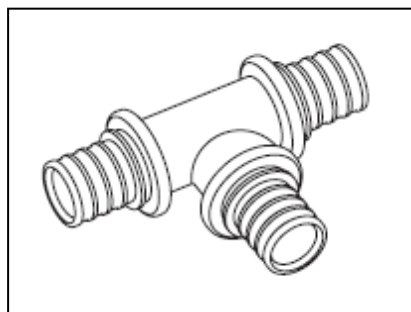

Article No.	Nominal Size mm	A (mm)	B (mm)	C (mm)	Z1	Z2	Z3
169056-001	25 x 2.3	50.00	53.50	50.00	24.50	28.0	24.50
169063-001	32 x 2.9	59.25	64.00	59.25	28.25	33.0	28.25
169072-001	40 x 3.7	67.00	75.00	67.00	35.00	43.00	35.00
169156-001	50 x 4.6	89.30	88.90	89.30	46.50	46.00	46.50
169167-001	63 x 5.8	104.50	107.50	104.50	54.50	57.50	54.50
221946-001	75 x 6.8	116.50	116.50	116.50	66.50	66.50	66.50
221948-001	90 x 8.2	125.50	125.50	125.50	75.50	75.50	75.50
221953-001	110 x 10.0	136.50	136.35	136.50	89.50	86.50	89.50

### TECHNICAL DESCRIPTION

Material	Brass
----------	-------

### FUNCTIONAL DESCRIPTION

SDR11 compression-sleeve fittings are ideal for all heating and snow and ice melting applications, as well as hydronic distribution connections. SDR11 compression-sleeve fittings and sleeves create reliable connections that can be walled in or embedded directly in a thermal mass when wrapped in chloride-free tape or RAUCROSS™ heat shrink tubing to help reduce corrosion caused by the surrounding environment. Check local codes for compliance. Installation is performed with SDR11 compression-sleeve tools. Tapered end of sleeve installs toward fitting. Follow all published installation instructions. Not certified for potable water.

Forgings are produced from solid brass rod (sizes 25 to 63 mm).

For updates to this publication, visit [na.rehau.com/resourcecenter](http://na.rehau.com/resourcecenter)

The information contained herein is believed to be reliable, but no representations, guarantees or warranties of any kind are made as to its accuracy, suitability for particular applications or the results to be obtained therefrom. Before using, the user will determine suitability of the information for user's intended use and shall assume all risk and liability in connection therewith.

© 2018 REHAU