

Please read and save these instructions. Read carefully before attempting to assemble, install, operate or maintain the product described. Protect yourself and others by observing all safety information. Failure to comply with instructions could result in personal injury and/or property damage! Retain instructions for future reference.

Operating Instructions and Parts Manual

Dual Suction Series

SPECIFICATIONS

POWER SUPPLY REQUIREMENTS	120 V, 60 Hz
MOTOR	Single Phase, Dielectric Oil Filled
HORSEPOWER	1/2 HP.....(F50CISDS) 1/3 HP.....(F33CISDS)
CIRCUIT REQUIREMENTS	15 A (minimum)
DIMENSIONS	12 in. high x 7-1/2in. base (ALL MODELS)
ON LEVEL (FACTORY SET)	Approximately 9 in. (ALL MODELS)
OFF LEVEL (FACTORY SET)	Approximately 4 in. (ALL MODELS)

CONSTRUCTION

MOTOR HOUSING	Cast Iron
MOTOR SHAFT	Carbon Steel
IMPELLER	Dual Glass Reinforced Thermoplastic
VOLUTE	Cast Iron
PUMP DISCHARGE	1-1/2 in. NPT

PERFORMANCE (Gal/hr)

Model	HP	Discharge Head (Lift Distance)				
		0 ft	5 ft	10 ft	15 ft	20 ft
F50CISDS	1/2	5200	4400	3500	2500	1200
F33CISDS	1/3	4500	3000	2900	1800	500

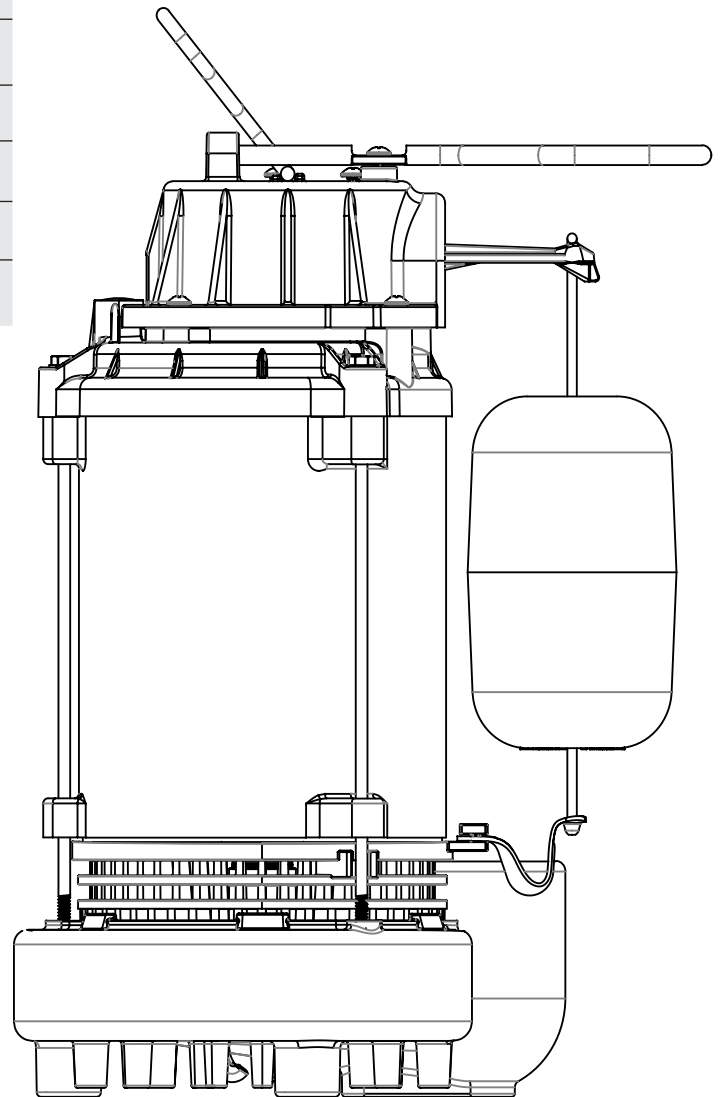

Intended for Indoor Use Only

INSTALLATION MANUAL

DUAL SUCTION SUMP PUMP DESCRIPTION

Sump Pumps are automatic pumps used to remove ground water from sump pits. The most common application is for basement drainage to prevent flooding in residential buildings. Sump pumps are designed to pump clear water only. These pumps are not designed to be used with a portable generator. The top suction (above the impeller) eliminates the risk of airlock and the suction screen filters debris. The bottom suction (below the impeller) passes up to 1/2 in. solids and filters debris through the heavy duty, cast iron, multi-ring strainer base to reduce clogging, and provide ultimate water flow.

Intended for indoor use only. Installation of this pump outdoors, unprotected from the weather, may cause hazardous conditions and will void warranty. Water inside the pump may freeze, limiting its performance and damaging the pump and pipes.

UNPACKING

Inspect this unit before it is used. Occasionally, products are damaged during shipment. If the pump or components are damaged, return the unit to the place of purchase for replacement, or call Customer Support (888-636-6628).

SAFETY SIGNAL WORDS

This manual contains information that is very important to know and understand. This information is provided for SAFETY and to PREVENT EQUIPMENT PROBLEMS. To help recognize this information, observe all safety information labeled danger, warning, caution, and notice.

IMPORTANT SAFETY INFORMATION CONSIGNES DE SÉCURITÉ IMPORTANTES

WARNING

WARNING INDICATES A POTENTIALLY HAZARDOUS SITUATION WHICH, IF NOT AVOIDED, COULD RESULT IN DEATH OR SERIOUS INJURY.

AVERTISSEMENT

LA MENTION AVERTISSEMENT INDIQUE UNE SITUATION POTENTIELLEMENT DANGEREUSE QUI, SI ELLE N'EST PAS ÉVITÉE, RISQUE D'ENTRAÎNER DES LÉSIONS CORPORELLES GRAVES OU MÊME LA MORT.

RISK OF ELECTRIC SHOCK. TO REDUCE THIS RISK, OBSERVE THE FOLLOWING WARNINGS:

RISQUE DE CHOC ÉLECTRIQUE. POUR RÉDUIRE CE RISQUE, TENIR COMPTE DES AVERTISSEMENTS SUIVANTS



MAKE SURE THERE IS A PROPERLY GROUNDED RECEPTACLE AVAILABLE. This pump is supplied with a grounding conductor and grounding-type attachment plug. To reduce the risk of electric shock, be certain that it is connected only to a properly grounded, grounding-type receptacle.

S'ASSURER QU'UNE PRISE DE MISE À LA TERRE EST DISPONIBLE. Cette pompe est fournie avec un conducteur et une fiche de mise à la terre. Pour réduire le risque de choc électrique, s'assurer qu'elle est branchée seulement à une prise de courant correctement mise à la terre.

FOR ADDED SAFETY the receptacle must be protected with a ground fault circuit interrupter (GFCI). All wiring must be performed by a qualified licensed electrician and comply with the National Electric Code and all applicable local codes and ordinances.

POUR PLUS DE SÉCURITÉ, la prise de courant doit être protégée par un disjoncteur de fuite à la terre. Tout le câblage doit être effectué par un électricien qualifié et être conforme au Code électrique national et à tous les codes et règlements locaux applicables.

NEVER REMOVE THE GROUND PRONG from the plug or bypass the grounding wires.

NE JAMAIS RETIRER LE CONNECTEUR DE MISE À LA TERRE de la prise ou contourner les fils de mise à la terre.

MAKE SURE THE POWER SUPPLY HAS A FUSE OR CIRCUIT BREAKER rated to handle the current (amps) noted on the pump nameplate or cord tag.

S'ASSURER QUE L'ALIMENTATION ÉLECTRIQUE EST MUNIE D'UN FUSIBLE OU D'UN DISJONCTEUR d'une valeur nominale appropriée pour supporter l'intensité du courant (ampérage) indiquée sur la plaque signalétique de la pompe.

ALWAYS DISCONNECT THE PUMP from power supply before installing, servicing or making any adjustments.

TOUJOURS METTRE LA POMPE HORS TENSION avant de procéder à l'installation, à l'entretien ou à des réglages.

DO NOT WALK on the floor when water is present until all power is turned off. If the electric panel is in the basement, call an electrician.

NE PAS MARCHER sur un sol mouillé avant que l'alimentation générale ne soit coupée. Si le tableau électrique est en sous-sol, appeler un électricien.

NEVER HANDLE A PUMP or motor with wet hands or when standing on a wet or damp floor while the pump is plugged into the power supply.

NE JAMAIS MANIPULER UNE POMPE ou un moteur de pompe avec les mains mouillées ou debout dans l'eau ou sur une surface humide.

RISK OF ELECTRIC SHOCK. This pump has not been investigated for use in swimming pool and marine areas.

RISQUE DE CHOC ÉLECTRIQUE. Cette pompe n'a pas fait l'objet de vérification pour une utilisation dans les piscines et les aires marines.

DO NOT USE TO PUMP FLAMMABLE OR EXPLOSIVE FLUIDS such as gasoline, fuel oil, kerosene, etc. Do not use in a flammable and/or explosive atmosphere. Pump should only be used to pump clear water. Personal injury and/or property damage will result and void warranty.

NE PAS UTILISER POUR POMPER DES FLUIDES INFLAMMABLES OU EXPLOSIFS tels que l'essence, le mazout, le kérosène, etc. Ne pas utiliser dans un environnement inflammable et/ou explosif. La pompe ne doit être utilisée que pour pomper de l'eau claire. Des blessures corporelles et/ou des dégâts matériels pourraient en résulter.

PUMPS ARE NOT DESIGNED TO TRANSFER WATER INTENDED FOR DRINKING. Do not use the pump for moving water that will be used for potable/drinking water. Pump should only be used in applications for which it is designed.

LES POMPES NE SONT PAS CONÇUES POUR L'ACHEMINEMENT D'EAU DESTINÉE À LA CONSOMMATION. Ne pas utiliser la pompe pour transporter de l'eau qui sera utilisée comme de l'eau potable/destinée à la consommation. La pompe doit être utilisée uniquement dans les applications pour lesquelles elle est conçue.

⚠ WARNING

DO NOT USE AN EXTENSION CORD OR SURGE PROTECTOR. Extension cords and/or surge protectors could present a safety hazard if not sized properly, become damaged or the connection falls into the sump. If receptacle is not within reach of the pump's power cord, contact a qualified licensed electrician to install a new receptacle.

⚠ WARNING

NE PAS UTILISER DE RALLONGE NI DE PROTECTEUR DE SURTENSION. Les rallonges et/ou les protecteurs de surtension peuvent présenter un danger pour la sécurité s'ils ne sont pas correctement calibrés, s'ils sont endommagés ou si le raccordement tombe dans le puisard. Si la prise n'est pas à portée du cordon d'alimentation de la pompe, contacter un électricien qualifié pour installer une nouvelle prise.

⚠ CAUTION

CAUTION INDICATES A POTENTIALLY HAZARDOUS SITUATION WHICH, IF NOT AVOIDED, MAY RESULT IN MINOR OR MODERATE INJURY.

⚠ MISE EN GARDE

LA MENTION MISE EN GARDE INDIQUE UNE SITUATION POTENTIELLEMENT DANGEREUSE QUI, SI ELLE N'EST PAS ÉVITÉE, POURRAIT ENTRAÎNER DES BLESSURES MINEURES OU MODÉRÉES.

TO REDUCE THE RISK OF HAZARDS THAT CAN CAUSE INJURY OR PROPERTY DAMAGE, OBSERVE THE FOLLOWING WARNINGS:

POUR RÉDUIRE LE RISQUE DE DANGERS POUVANT CAUSER DES BLESSURES OU DES DÉGÂTS MATÉRIELS, RESPECTER LES MISES EN GARDE SUIVANTES :



IT IS THE INSTALLER'S RESPONSIBILITY TO MAKE SURE THE PUMPS AUTOMATIC SWITCH IS ABLE TO OPERATE WITHOUT ANY OBSTRUCTIONS WITHIN THE BASIN. It is recommended that the installer test and observe the pump's operation for several cycles after installation.

IL EST DE LA RESPONSABILITÉ DE L'INSTALLATEUR DE S'ASSURER QUE L'INTERRUPTEUR AUTOMATIQUE DE POMPE PEUT FONCTIONNER SANS AUCUN BLOCAGE À L'INTÉRIEUR DU SYSTÈME. Il est recommandé que l'installateur teste et observe le fonctionnement de la pompe pendant plusieurs cycles après l'installation.

INSTALLATION MANUAL

IT IS REQUIRED TO USE RIGID PIPING AND FITTINGS to secure the pump in the basin and reduce pump movement. Pump movement can prevent the switch from operating correctly. Do not use flexible hosing.

IL EST NÉCESSAIRE D'UTILISER DES TUYAUX ET DES RACCORDS RIGIDES pour fixer la pompe dans le système et réduire les mouvements de la pompe. Les mouvements de la pompe peuvent empêcher l'interrupteur de fonctionner correctement. Ne pas utiliser de tuyaux flexibles.

IT IS REQUIRED TO USE A CHECK VALVE with this pump to prevent the back-flow of clear ground water after each pump cycle.

Cette pompe **NÉCESSITE L'UTILISATION D'UNE VANNE DE CONTRÔLE** pour empêcher le reflux d'eau souterraine claire après chaque cycle de pompage.

DO NOT INSTALL OR OPERATE THE PUMP IF IT HAS BEEN DAMAGED IN ANY WAY.

NE PAS INSTALLER OU FAIRE FONCTIONNER LA POMPE SI ELLE A ÉTÉ ENDOMMAGÉE DE QUELQUE MANIÈRE QUE CE SOIT.

DO NOT LIFT OR CARRY THE PUMP BY THE POWER CORD. Use the pump's handle or lift ring.

NE PAS SOULEVER OU PORTER LA POMPE PAR LE CORDON D'ALIMENTATION. Utiliser la poignée ou la bague de levage de la pompe.

AN INDEPENDENT HIGH WATER ALARM OR BACK UP PUMP SHOULD BE USED when risk of property damage from high water levels exists.

UNE ALARME AUTONOME DE NIVEAU D'EAU ÉLEVÉ OU UNE POMPE DE SAUVEGARDE DOIVENT ÊTRE UTILISÉES en cas de risque de dégâts matériels causés par des niveaux d'eau élevés.

WARNING

This product can expose you to chemicals, including DEHP, which is known to the State of California to cause cancer, birth defects and reproductive harm. For more information, go to www.P65Warnings.ca.gov

AVERTISSEMENT

Ce produit peut vous exposer à des produits chimiques, notamment du DOP, reconnus par l'État de Californie comme étant cancérigènes et à l'origine d'anomalies congénitales et de problèmes de l'appareil reproductif. Pour plus de renseignements, visiter le site www.P65Warnings.ca.gov

TYPICAL SUMP INSTALLATION

1. This installation must be in accordance with the National Electric Code and all applicable local codes and ordinances.
2. Clean the basin of all debris.
3. Set the pump on a solid, level surface. Do not place pump directly on clay, earth, gravel, or sand. A brick or block may be installed under the pump to provide a solid base.
4. Verify the float switch (8) has at least 1 inch clearance to the side wall of the basin (9) and is free of any possible obstructions.
5. If optional control device or float is used, follow mounting instructions supplied with device or float.
6. Install discharge plumbing according to local, regional and state codes. Do not reduce the discharge pipe size below that which is provided on the pump.
7. Install a check valve (2) (required) to prevent back-flow.
8. A gate valve or ball valve should be installed above the check valve if required by local, regional or state codes.
9. Connect remaining discharge pipe. Keep sections as short as possible with a minimum number of turns.
10. Secure power supply cord (10) to discharge pipe using cable or zip ties to prevent possible switch entanglement.
11. Connect pump power supply cord to a ground fault circuit interrupter (GFCI) outlet.
12. Fill the basin with water. The pump will start when the water level has reached the switch-on level. Verify the pump is operating normally. If the discharge line is exposed to freezing temperatures, the pipe must be positioned in a downward slope away from the foundation so any remaining water will drain away and not freeze.
13. Secure a basin/tank cover and gasket to the basin to prevent debris from falling into the basin, prevent personal injury, and to contain gases and/or odors.

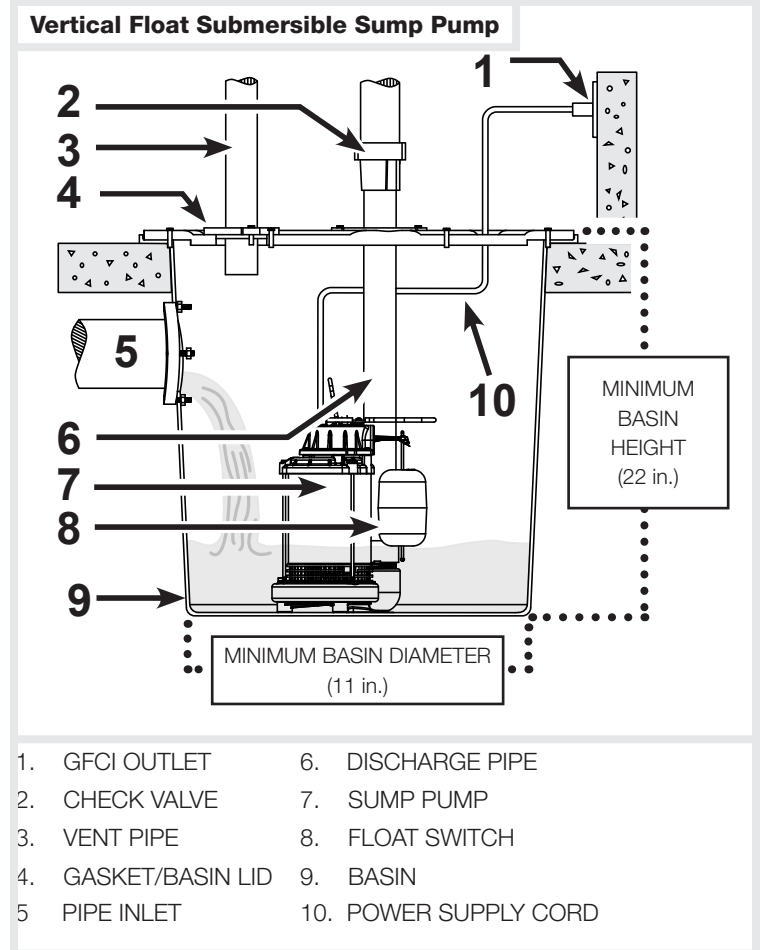

INSTALLATION MANUAL

TROUBLESHOOTING WARNINGS

WARNING

ALWAYS DISCONNECT THE PUMP FROM POWER SUPPLY before installing, servicing or making any adjustments.

AVERTISSEMENT

TOUJOURS METTRE LA POMPE HORS TENSION avant de procéder à l'installation, à l'entretien ou à des réglages.

WARNING

LET PUMP COOL FOR A MINIMUM OF 2 HOURS BEFORE ATTEMPTING TO SERVICE. Submersible pumps contain oil that become pressurized and hot under normal operating conditions.

AVERTISSEMENT

LAISSER REFROIDIR LA POMPE PENDANT AU MOINS 2 HEURES AVANT D'ESSAYER DE LA RÉPARER. Les pompes submersibles contiennent de l'huile qui devient pressurisée et chaude dans des conditions normales de fonctionnement.

1. Submersible pump models have permanently lubricated bearings and require no additional lubrication.
2. Submersible pumps contain dielectric oil for cooling. Dielectric oil can be harmful to the environment. Follow state environmental laws when disposing of pump.
3. The pump motor is equipped with an automatic resetting thermal protector and may restart unexpectedly. Protector tripping is an indication of motor overloading; as a result of operating the pump at low heads, excessively high or low voltage, inadequate wiring, incorrect motor conditions, or at the end of product life.

TROUBLESHOOTING

Symptoms	Possible Cause(s)	Suggested Remedies
Pump will not start or run	<ol style="list-style-type: none">1. Water level too low2. Blown fuse or tripped circuit breaker3. Low supply voltage4. Motor5. Switch6. Inlet clogged7. Switch obstruction	<ol style="list-style-type: none">1. Water must be at the appropriate level to activate switch2. If blown or tripped, determine cause; then either replace with proper sized fuse reset GFCI outlet or circuit breaker3. Contact an electrician4. Replace pump5. Replace pump6. Remove debris7. Remove obstruction to verify free motion of switch
Pump starts and stops too often	<ol style="list-style-type: none">1. Back-flow of water from discharge pipe2. Switch3. Check valve not functioning properly or leaking	<ol style="list-style-type: none">1. Install check valve2. Replace pump3. Remove and examine check valve for proper installation and free operation. Replace check valve if necessary.
Pump shuts off and turns on independently of switch (trips thermal overload protection)	<ol style="list-style-type: none">1. Switch2. Switch obstruction3. Obstruction in discharge pipe4. Low supply voltage	<ol style="list-style-type: none">1. Replace pump2. Remove obstruction to verify free motion of switch3. Remove obstruction in discharge piping4. Contact an electrician.

INSTALLATION MANUAL

TROUBLESHOOTING (CONTINUED)

Symptoms	Possible Cause(s)	Suggested Remedies
Pump trips GFCI	<ol style="list-style-type: none">1. Bad GFCI2. Bad pump	<ol style="list-style-type: none">1. Contact and electrician to replace GFCI2. Replace pump
Pump will not shut off	<ol style="list-style-type: none">1. Switch2. Switch obstructions3. Restricted discharge (obstruction in piping)4. Excessive inflow or pump not properly sized for application	<ol style="list-style-type: none">1. Replace pump2. Remove obstruction to verify free motion of switch3. Remove obstruction from discharge piping4. Recheck all sizing calculations to determine proper pump size
Pump operates but delivers little or no water	<ol style="list-style-type: none">1. Low supply voltage2. Inlet clogged3. Broken impeller4. Pump not properly sized for application5. Check valve stuck closed or installed backwards6. Shut off valve closed	<ol style="list-style-type: none">1. Contact an electrician2. Remove debris3. Replace pump4. Recheck all sizing calculations to determine proper pump size5. Remove and examine check valve for proper installation and free operation6. Open valve

ROUTINE MAINTENANCE

The pump should be inspected 3-4 times per year for pump movement or buildup of debris on the switch or float. Reposition pump if it has moved. Remove any debris that could interfere with the operation of the switch. Lack of proper routine maintenance will void warranty.

- Make sure the pump is plugged in to a working ground fault circuit interrupter (GFCI) outlet and the cord is in good shape. In damp areas, GFCI breakers may trip, effectively shutting off the sump pump. Check your sump pump and reset the GFCI if necessary. Replace pump if it continues to trip a known good GFCI.
- Ensure the pump is standing upright. Vibrations during operation can cause it to fall or tilt onto one side. This can jam the float arm so it can't activate the pump.
- Pour a bucket of water into the pit to make sure the pump starts automatically and the water drains quickly once the pump is on. If the pump doesn't start, have it serviced or replaced.

WARRANTY & SERVICE PARTS SHEET - REPLACEMENT PARTS

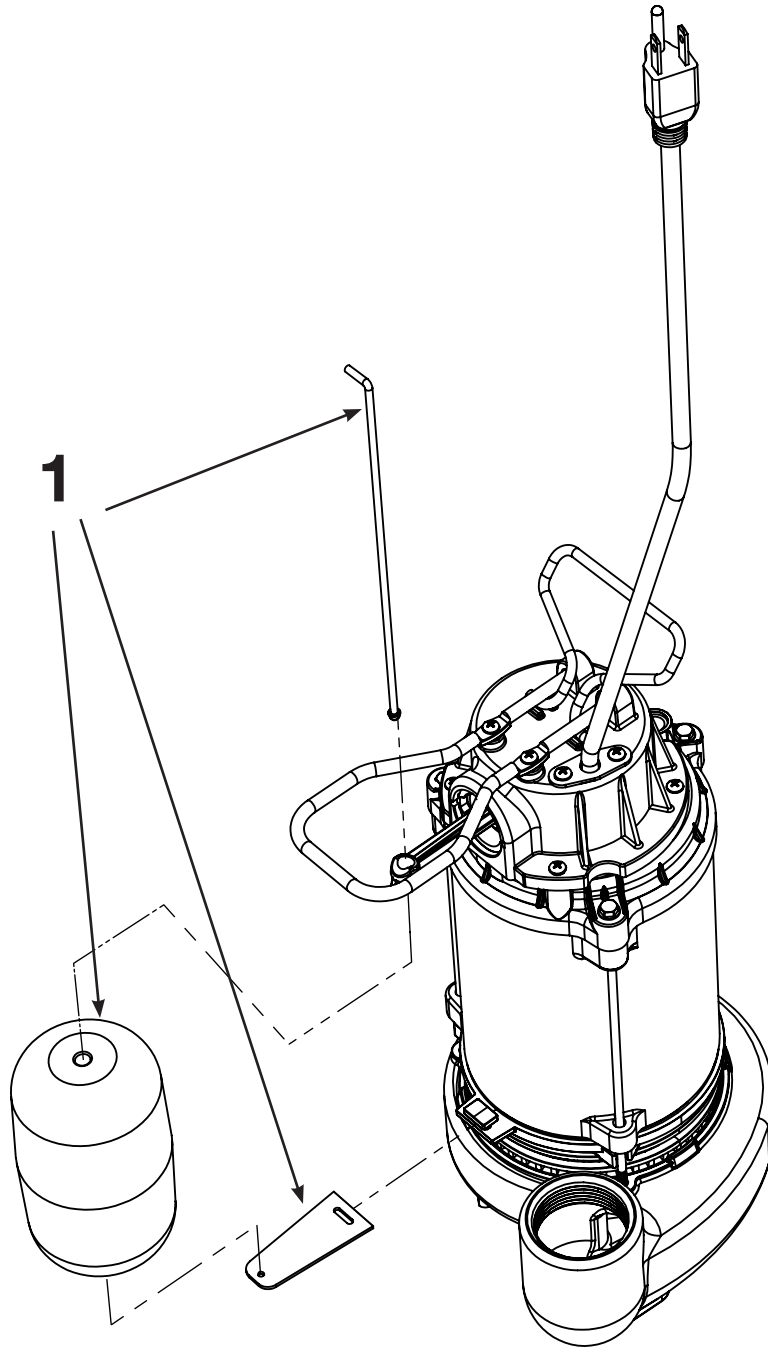

REPAIR KITS

ALL MODELS

REF. NO.	DESCRIPTION	PART NUMBER
1	FLOAT KIT	60038-WYN1

INSTALLATION MANUAL

**FOR REPLACEMENT
PARTS OR CUSTOMER SUPPORT,
CALL 1-888-636-6628**

**ADDRESS PARTS CORRESPONDENCE TO:
BLUE ANGEL PUMPS
101 Production Drive
Harrison, OH 45030 U.S.A.**

Please provide following information:

- Model number
- Serial number on cord tag (not to be removed)
- Part description and number as shown in parts list

Thank you for making Blue Angel a key part of your home maintenance program. If properly installed, maintained and operated in accordance with Blue Angel's written instructions, your pump should provide you with approximately (*) years of service.

Product Warranty	(*) Expected Life
1	3
2	3
3	6
5	6

LIMITED WARRANTY

For five years for F50CISDS and F33CISDS models from the date of purchase, from an authorized dealer, Blue Angel Pumps will repair or replace, at its option for the original purchaser, any part or parts of its Sump Pumps or Water Pumps ("Product") found upon examination by Blue Angel Pumps to be defective in materials or workmanship. Please call Blue Angel Pumps (888-636-6628) for warranty instructions. Be prepared to provide the model number and the serial number when exercising this warranty. All transportation charges on products or parts submitted for repair or replacement must be paid by purchaser. This Limited Warranty is not transferrable. This Limited Warranty does not cover Products which have been damaged as a result of accident, abuse, misuse, neglect, improper installation, improper maintenance, or failure to operate in accordance with BLUE ANGEL PUMPS written instructions.

This Limited Warranty does not cover Products which have been damaged as a result of accident, abuse, misuse, neglect, improper installation, improper maintenance, or failure to operate in accordance with Blue Angel Pumps written instructions.

THIS WARRANTY IS IN LIEU OF ANY AND ALL OTHER WARRANTIES, OBLIGATIONS OR AGREEMENTS, EXPRESSED OR IMPLIED, INCLUDING ANY IMPLIED WARRANTY OF MERCHANTABILITY OR FITNESS FOR ANY PARTICULAR PURPOSE, AND ANY RIGHTS OR REMEDIES AGAINST ANY PERSON OR ENTITY UNDER THE UNIFORM COMMERCIAL CODE OR OTHERWISE WITH RESPECT TO THE SALE OF THE PRODUCT. THE REMEDIES AND OBLIGATIONS STATED IN THIS WARRANTY ARE THE SOLE AND EXCLUSIVE REMEDIES OF AND OBLIGATIONS TO THE OWNER FOR ANY AND ALL MATTERS ARISING WITH RESPECT TO OR IN ANY WAY CONNECTED WITH THE PRODUCT, REGARDLESS OF THE SOURCE OR PROVIDER OF SUCH GOODS. IN NO EVENT, WHETHER AS A RESULT OF BREACH OF CONTRACT, WARRANTY TORT (INCLUDING NEGLIGENCE) OR OTHERWISE, SHALL BLUE ANGEL PUMPS OR ANY AFFILIATE BE LIABLE FOR ANY SPECIAL, INCIDENTAL OR CONSEQUENTIAL DAMAGES.

You **MUST** retain your purchase receipt along with this form. In the event you need to exercise a warranty claim, you **MUST** send a **copy** of the purchase receipt along with the material or correspondence. Please call Blue Angel Pumps (888-636-6628) for return authorization and instructions.

DO NOT MAIL THIS FORM TO Blue Angel Pumps. Use this form only to maintain your records.

MODEL NO. _____ SERIAL NO. _____ INSTALLATION DATE _____

ATTACH YOUR RECEIPT HERE