

VOLTEX® 120V PLUG-IN HYBRID ELECTRIC HEAT PUMP WATER HEATER

The Voltex 120V Plug-In Hybrid Electric heat pump water heater from A. O. Smith makes it easier than ever for consumers to electrify for an energy-efficient option to save money on their utility bills. These models plug into a standard wall outlet for easy installation and provide annual savings up to \$118 on utility bills* compared to a gas water heater. Plus homeowners gain added peace of mind with new leak protection features including leak detection and automatic water shutoff.

HOW DO THEY WORK?

- Absorb ambient heat from the surrounding air to heat water using a compressor
- Self-contained heat pump unit is integrated into the top of the tank
- Backup electric heating elements provide hot water if the heat pump is unable to operate

QUALIFIES FOR MANY FEDERAL, STATE & LOCAL UTILITY REBATES - CHECK HOTWATER.COM

EASY INSTALLATION

- Simply plugs into a standard 120 volt wall outlet (certified for use on a shared circuit)
- Contractor preferred top water connections for easy replacement of a gas water heater
- 450 ft³ space requirement is lower than other heat pump water heaters (plus there are a variety of options for installation in smaller spaces)
- Zero clearance required on sides and back to fit in tighter spaces
- Integrated ducting adapters for easy installation in confined spaces

WHISPER-QUIET OPERATION AT 45 dBA

- No vibration isolation kit required

LEAK PROTECTION TECHNOLOGY

- Smart anode adapts to local water conditions to protect and extend the life of the water heater
- Controls regulate depletion of the anode to extend the life of the anode allowing superior tank protection far longer than standard anode rods
- User is notified when the anode is consumed and needs to be replaced
- Smart sensor leak detection and automatic water shutoff for added peace of mind and enhanced protection

EASY TO CONTROL

- Digital control to easily set outlet water temperature
- No manual mixing valve to adjust or service
- Integrated iCOMM™ smart connectivity through Wi-Fi and Bluetooth
- Monitor and control your water heater through the free A. O. Smith app
- If applicable download the Time of Use schedule of your local electric utility to prioritize heating when the rates are most affordable

LOWER GWP REFRIGERANT

- Utilizes R-513A refrigerant for a smaller carbon footprint
- 56% lower global warming potential** than the standard refrigerant used in other residential heat pump water heaters

HIGH EFFICIENCY HEAT PUMP OPERATION

- Up to 3.2 Uniform Energy Factor (UEF) can reduce the cost of water heating by up to 35%*
- Heat pump can work down to 37°F

10-YEAR LIMITED WARRANTY

- For complete information, consult written warranty or go to hotwater.com



*Comparing 66-gallon Voltex 120V heat pump against pre-2015 similarly-sized standard gas water heater using DOE EF to UEF conversion rates \$0.14 per kWh electricity and \$1.21 per therm of natural gas.

**Comparing R-513A (630 GWP) against the most commonly used refrigerant R-134a (1,430 GWP) from the IPCC's fourth Assessment Report (AR4)



COMMERCIAL-GRADE RESIDENTIAL ELECTRIC WATER HEATERS

Model Number	Nominal Capacity	Rated Storage Volume	UEF	First Hour Rating (gallons)	Dimensions in Inches						Approx Shipping Weight (lbs)	Warranty Term
					A	B	C	D	E	F		
HPTV-50	50	46	3.0	52	67.75	22	39.5	3.75	8	43.5	196	10
HPTV-66	66	68	3.2	76	61.5	26.5	38.25	4	8	46	289	10
HPTV-80	80	82	3.0	93	69	26.5	46.5	4	8	54.5	307	10

Top T&P option not available.

SIZING RECOMMENDATION FOR EQUIVALENT FIRST HOUR RATING

Voltex 120V Plug-In Heat Pump		Gas Water Heater
Model	Nominal Capacity	Nominal Capacity
HPTV-50	50 gal (52 FHR)	30 gal (50-60 FHR)
HPTV-66	66 gal (76 FHR)	40 gal (60-75 FHR)
HPTV-80	80 gal (93 FHR)	50 gal (80-100 FHR)

Voltex AL is recommended to replace a standard electric water heater or for use in new construction.

ADVANCED QUALIFICATIONS

- NEEA Tier 3
- California Title 24 JA13 Qualified
- ASSE 1082
- CTA-2045 (AC)
- OpenADR 2.0b VEN
- HUD Compliant

OTHER FEATURES:

- Environmentally-friendly, non-CFC foam insulation
- Durable, enhanced-flow brass drain valve
- CSA certified and ASME rated temperature & pressure relief valve

OPERATING REQUIREMENTS:

- Requires provision for non-acidic condensate draining; if a suitable drain is not available a condensate pump is required
- 120 VAC 60Hz single phase 15 amp shared circuit

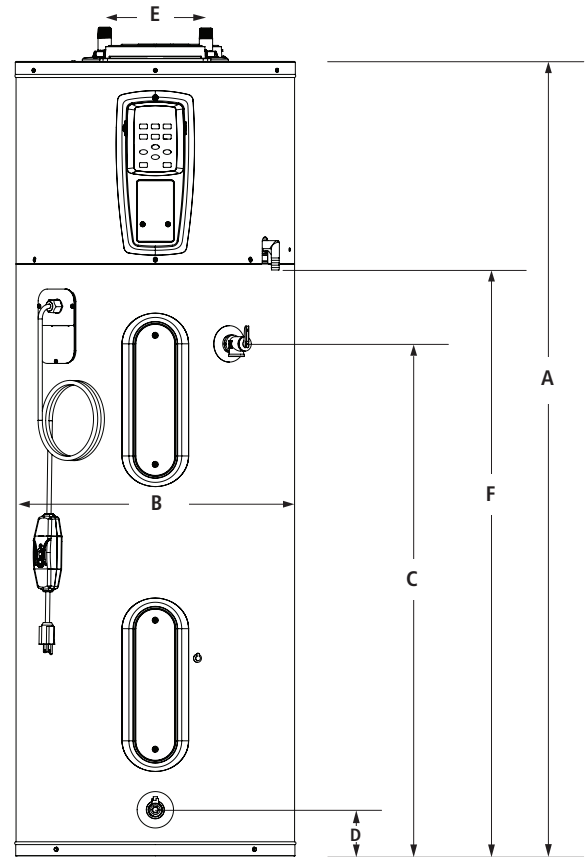

iCOMM™ SMART CONNECTIVITY

Download the free A. O. Smith app to get started.

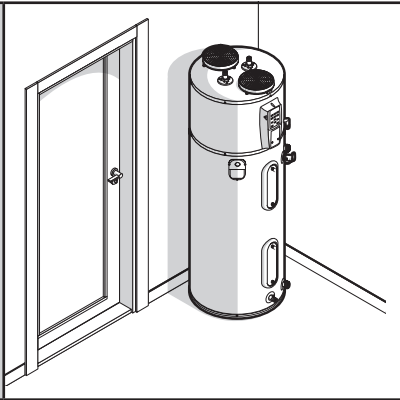
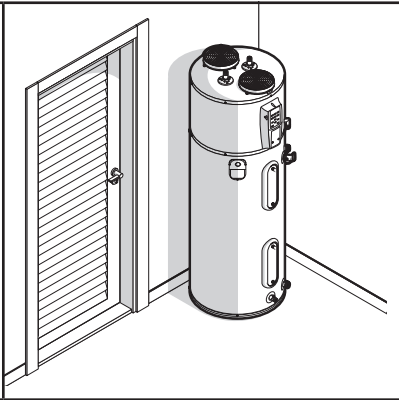

Apple logo and Apple App Store Logo are trademarks of Apple Inc.
Google Play and the Google Play logo are trademarks of Google LLC.

450 FT³ ENCLOSED ROOM SIZE IS 35% SMALLER THAN OTHER MANUFACTURERS REQUIRE

			
Configuration	Enclosed Room	Fully Louvered Door	Upper and Lower Louvers in Door ^{1,2}
Minimum Space (FT³)	450	84	84
Space Example L x W x H (FT)	6 x 7.5 x 10	3 x 2.8 x 10	3 x 2.8 x 10

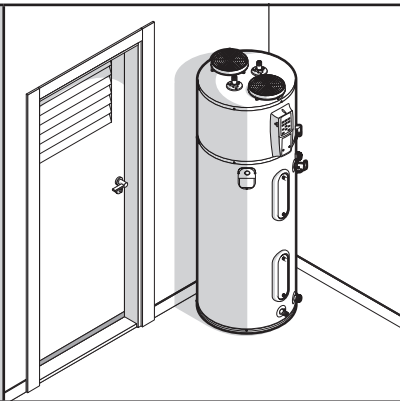
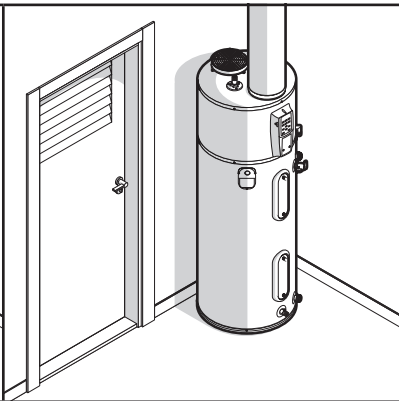
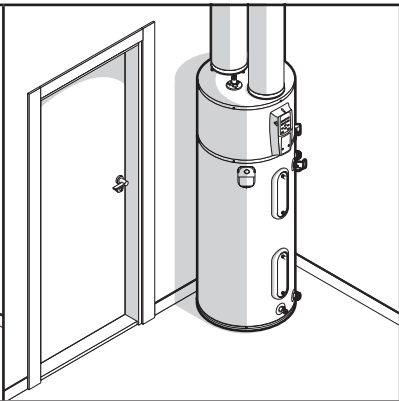
			
Configuration	Upper Louver and Undercut Door ^{1,3,4}	Inlet OR Outlet Ducting and a Single Louver OR Undercut Door ^{1,3,4,5}	Inlet AND Outlet Ducting ⁵
Minimum Space (FT³)	84	No minimum space requirement	No minimum space requirement
Space Example L x W x H (FT)	6 x 7.5 x 10		

¹Minimum louver size is 130 in² free area each.

²When two louvers are installed, install one louver at the top of the heater and the other close to the floor.

³Undercut door should have a minimum of 0.75" clearance. (minimum 18 in² air gap)

⁴When one louver is installed, install the louver in a location close to the top of the heater.

⁵This heater supports multiple duct diameters as well as rigid and flex ducting options. See manual for more information.

For Technical Information, call 800-527-1953. A. O. Smith Corporation reserves the right to make product changes or improvements without prior notice.