

AngleMix™ DL Thermostatic mixing valves, dual listed

© Copyright 2024 Caleffi

520 Series

Function



ASSE 1017
ASSE 1070
NSF/ANSI/CAN 372

The Caleffi AngleMix™ DL 520 series thermostatic mixing valve is used in systems producing domestic hot water and easily mounts to the top of water heaters. In addition to point of distribution applications, the DL model is factory set for point of use applications, limiting the maximum mixed outlet temperature to prevent scalding water temperatures. The mixed temperature outlet is inline with the hot water inlet, facilitating trouble-free connection and reducing space required for installation. The AngleMix DL maintains the desired output temperature of the mixed water supplied at a constant set value compensating for both temperature and pressure fluctuations of the incoming hot and cold water. The mixing valve closes its inlet ports tight, eliminating temperature creep in recirculation loops. The angle style body design offers improved fluid dynamics for better performance and reduces installation labor and materials, eliminating a piping elbow in typical installations.

The AngleMix DL complies with both ASSE 1070/ASME A112.1070/CSA B125.70 and ASSE 1017 and CSA B125.3. The DL model is factory configured with an adjustment knob limiting mixed outlet temperature to 120 °F maximum. The device can be converted to ASSE 1017 function by removing the rotation limiting screw. In addition, it is certified for compliance with NSF/ANSI/CAN 372, low lead/lead free laws and use according to U.S. and Canadian plumbing codes. AngleMix DL listed and certified by ICC-ES, listing certificates detailed on page 2.

Product range

520__AC series: Adjustable three-way thermostatic mixing valve with mixed outlet temperature gauge, angle body with inlet port check valves.....
connections 1/2", 3/4" press, NPT male, sweat union.
PEX crimp and expansion

Technical specification

Materials

Valve body: DZR low-lead* brass
Shutter, seats and slide guides: PSU
Springs: stainless steel
Seals: peroxide-cured EPDM
Adjustment knob: ABS

* Meets the "lead free" requirement of Section 1417 of the Safe Drinking Water Act (SDWA). This product has a weighted average lead content of less than 0.25% for its wetted surfaces contacted with consumable water.

Flow coefficient: $C_v=2.0$ ($K_v=1.7$)

Minimum flow rate for stable operation with balanced supply pressure conditions:

0.5 gpm (2 l/min)

Maximum flow rate for temperature stability:

9 gpm (34 l/min)

Performance

Suitable fluids: water
Setting range: 95–150 ° F (35–65 ° C)
Factory-setting: limited to 120 ° F (50 ° C)
Tolerance: ± 3 ° F (± 2 ° C)

Mixed outlet temperature gauge: 2" diameter

Dual-scale 32 ° F to 210 ° F (0 ° C to 100 ° C)

Accuracy: 1% full-scale

Max. working pressure (static): 150 psi (10 bar)

Max. working pressure (dynamic): 75 psi (5 bar)

Max. hot water inlet temperature:

195 ° F (90 ° C)

Max. inlet pressure ratio (H/C or C/H) for optimal performance: 2:1

Certifications:

1. ASSE 1017, CSA B125.3, UPC, IPC, IRC and NPC for use in accordance with U.S. and Canadian plumbing codes. Certified and listed by ICC-ES, File PMG 1357.
2. ASSE 1070/ASME A112.1070/CSA B125.70 and CSA B125.3. Certified and listed by ICC-ES, PMG File 1358.
3. NSF/ANSI /CAN 372, Drinking Water System Components-Lead Content Reduction of Lead in Drinking Water Act, California Health and Safety Code 116875 S.3874, Reduction of Lead in Drinking Water Act, certified by ICC-ES, file PMG-1360.
4. PEX crimp fittings certified to ASTM F 1807.
5. PEX expansion fittings certified to ASTM F 1960.

In ASSE 1017 mode

Minimum temperature difference between hot water inlet and mixed water outlet for stable operation with balanced supply pressure conditions:

9 ° F (5 ° C)

Recommended minimum temperature difference between hot water inlet and mixed water outlet for optimal performance:

18 ° F (10 ° C)

Required minimum temperature difference between hot water inlet and mixed water outlet for thermal shut-off function:

18 ° F (10 ° C)

In ASSE 1070 mode

Recommended minimum temperature difference between hot water inlet and mixed water outlet for optimal performance:

27 ° F (15 ° C)

Required minimum temperature difference between hot water inlet and mixed water outlet for thermal shut-off function:

27 ° F (15 ° C)



SAFETY INSTRUCTION

This safety alert symbol will be used in this manual to draw attention to safety related instructions. When used, the safety symbol means **ATTENTION! BECOME ALERT! YOUR SAFETY IS INVOLVED! FAILURE TO FOLLOW THESE INSTRUCTIONS MAY RESULT IN A SAFETY HAZARD.**



WARNING: This product can expose you to chemicals including lead, which is known to the State of California to cause cancer and birth defects or other reproductive harm. For more information go to www.P65Warnings.ca.gov.



CAUTION: All work must be preformed by qualified personnel trained in the proper application, installation, and maintenance of systems in accordance with all applicable codes and ordinances.



CAUTION: If the thermostatic mixing valve is not installed, commissioned and maintained properly, according to the instructions contained in this manual, it may not operate correctly and may endanger the user.



CAUTION: Make sure that all the connecting pipework is water tight.

CAUTION: If installed in an ASSE 1070 application, check valves shall be used.



CAUTION: When making the water connections, make sure that the pipework connecting the AngleMix DL thermostatic mixing valve is not mechanically overstressed. Over time this could cause breakages, with consequent water losses which, in turn, could cause harm to property and/or people.



CAUTION: Water temperatures higher than 100 °F (38 °C) can be dangerous. During the installation, commissioning and maintenance of the AngleMix DL thermostatic mixing valve, take the necessary precautions to ensure that such temperatures do not endanger people.



CAUTION: To prevent any damage which will cause the electronic mixing valve to not operate correctly, treat highly aggressive water before entering the thermostatic mixing valve. Be sure water hardness is less than 10 grains.



WARNING: The outer surface of the device, especially in polymer type components, must not come into contact with any chemical substance, either on purpose or accidentally. The system fluid and any chemical additives used within the water piping system – whether for washing or as protection – must be compatible with the materials used to make the device and with the function it performs.

Calfeffi shall not be liable for damages resulting from stress corrosion, misapplication or misuse of its products.

LEAVE THIS MANUAL WITH THE USER.



CONSIGNE DE SÉCURITÉ

Ce symbole d'avertissement servira dans ce manuel à attirer l'attention sur la sécurité concernant instructions. Lorsqu'il est utilisé, ce symbole signifie.

ATTENTION! DEVEZ-VOUS AVOIR ! VOTRE SÉCURITÉ EST EN JEU ! NE PAS SUIVRE CES INSTRUCTIONS PEUT PROVOQUER UN RISQUE DE SÉCURITÉ.



AVERTISSEMENT: Ce produit peut vous exposer à des produits chimiques comme le plomb, qui est connu dans l'État de Californie pour causer le cancer, dommages à la naissance ou autre. Pour plus d'informations rendez-vous www.P65Warnings.ca.gov.



ATTENTION: Tous les travaux doivent être effectués par du personnel qualifié formé à la bonne application, installation et maintenance des systèmes conformément aux codes et règlements locaux.



ATTENTION: Si le réducteur de pression, thermostatique réglable, n'est pas installé, mis en service et entretenu correctement, selon les instructions contenues dans ce manuel, il peut ne pas fonctionner correctement et peut mettre en danger l'utilisateur.



ATTENTION: S'assurer que tous les raccordements sont étanches.
ATTENTION: S'il est installé dans un pays de ASSE 1070 application, vérifiez les robinets doivent être utilisés.



ATTENTION: Lorsque vous effectuez les raccordements d'eau, assurez-vous que la tuyauterie reliant le AngleMix DL thermostatique réglable n'est pas mécaniquement des overstressed. Au fil du temps, ceci pourrait causer des ruptures, avec pour conséquence des pertes en eau qui, à leur tour, peuvent causer des dommages à la propriété et/ou les gens.



ATTENTION: Les températures de l'eau supérieure à 100 °F (38 °C) peut être dangereux. Au cours de l'installation, mise en service et l'entretien de le réducteur de pression, le AngleMix DL thermostatique réglable, prendre les précautions nécessaires afin de s'assurer que de tels températures ne compromettent pas les gens.



ATTENTION: Pour prévenir tout dommage qui provoque le mitigeur électronique à ne pas fonctionner correctement, le traitement de l'eau très agressive avant d'entrer dans la thermostatique réglable. Assurez-vous que la dureté de l'eau est inférieure à 10 grains.



AVERTISSEMENT: La surface extérieure de l'appareil, en particulier les composants de type polymère, ne doit pas entrer en contact avec des substances chimiques, que ce soit volontairement ou accidentellement. Le produit et les additifs chimiques utilisés dans les canalisations d'eau - que ce soit pour le lavage ou la protection - doivent être compatibles avec les matériaux utilisés pour la fabrication de l'appareil et avec la fonction qu'il remplit.

Caleffi ne pourra être tenue responsable des dommages résultant de la corrosion, d'une mauvaise utilisation ou une mauvaise utilisation des produits.

LAISSEZ CE MANUEL AVEC L'UTILISATEUR

Operating principle

The thermostatic mixing valve mixes the hot and cold water at the inlets to maintain constant mixed water at the desired set temperature. A thermostatic sensor (1) is fully immersed in the mixed water outlet passage (2) which, as it expands or contracts, continuously establishes the correct proportion of hot and cold water entering the valve. The regulation of these flows is by means of a piston (3) sliding in a cylinder between the hot and cold water passages. This controls the passage of hot (4) or cold (5) water at the inlet. If the inlet temperature or pressure changes, the internal element automatically reacts to restore the set temperature at the outlet. The AngleMix DL 520_AC series point of distribution mixing valve is an angled configuration for easy installation to most water heaters for direct mounting to the top pipe connections. The AngleMix DL 520_AC series point of use mixing valve with inlet check valves and stop limited 120 °F maximum temperature setting easily mounts under sinks or tubs. It can also be used as a point of distribution valve, in ASSE 1017 mode, by removing the stop limit screw, allowing adjustment up to 150 °F. Posi-Stop™ union seals (6) on all three union tailpiece connections.

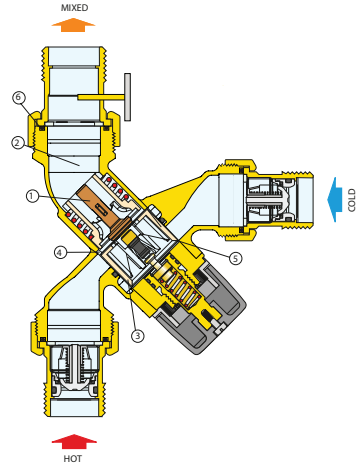

Flow curve

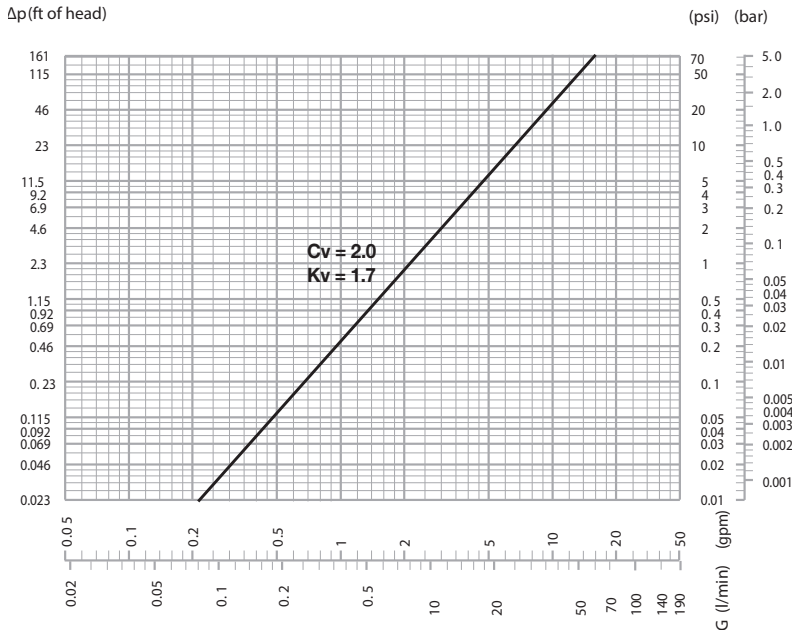

Use



Caleffi AngleMix DL 520_AC series thermostatic mixing valves are engineered for installation at either the point of distribution to regulate the temperature of the domestic hot water distributed within the downstream network, or at point of use for scald protection. The AngleMix DL 520_AC series mixing valve includes inlet tailpieces which have check valves, to meet the requirements of ASSE 1070. As a safety precaution, it is advisable to limit the maximum mixed water temperature at 120 °F when scald protection devices are not implemented at each fixture.

Construction details

Thermal shut-off

In the event of accidental cold water supply failure, the valve will quickly close the hot inlet port to prevent the delivery of unsafe hot water. This is only guaranteed when there is a minimum temperature difference between the inlet hot water and the mixed temperature water delivery of 18 °F (27 °F for point of use applications- in ASSE 1070 mode).

Body shape

The angle body configuration has improved fluid dynamics for better performance, and reduces installation labor and materials because the hot inlet port is in line with the mixed outlet port, eliminating a piping elbow as required for standard mixing valves. The cold inlet comes in the side.

Anti-scale materials

The materials used in constructing the mixing valve are designed to eliminate seizing due to limescale deposits. All functional parts have been made using a special anti-scale material with low friction coefficient, ensuring long life performance.

Certification

1. ASSE 1017 and CSA B125.3; and ASSE 1070/ASME A112.1070/CSA B125.70 and CSA B125.3. Certified by ICC-ES, file PMG-1357 and PMG-1358.

2. DZR low-lead brass body is in compliance to NSF/ANSI/CAN 372 as certified by ICC-ES, file PMG 1360.



Installation



Before installing a Caleffi AngleMix DL 520 series three-way thermostatic mixing valve, the system must be inspected to ensure that its operating conditions are within the range of the mixing valve, checking, for example, the supply temperature, supply pressure, etc.

Systems where the 520 series thermostatic mixing valve will be installed must be drained and cleaned out to remove any dirt or debris which may have accumulated during installation.

The installation of appropriately sized filters at the inlet from the main water supply is always advisable.

Caleffi AngleMix DL 520 series thermostatic mixing valves must be installed by qualified personnel in accordance with the diagrams in this brochure, taking into account all current applicable standards.

Caleffi AngleMix DL 520 series thermostatic mixing valves can be installed in any position, either vertical or horizontal, or upside down.

The following are shown on the thermostatic mixing valve body:

- Hot water inlet, color red and marked "HOT".
- Cold water inlet, color blue and marked "COLD".
- Mixed water outlet, marked "MIX".

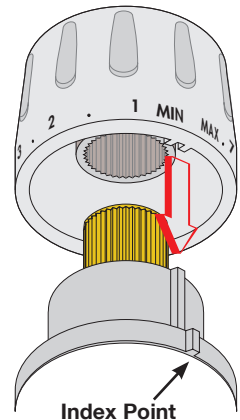

Locking the setting for AngleMix DL 520_AC, dual ASSE 1017 and ASSE 1070 models

Position the handle to the number required with respect to the index point. Unscrew the head screw, pull off the handle and reposition it so that the handle fits into the internal slot of the knob. Tighten the head screw.

Converting the AngleMix DL (ASSE 1070) to AngleMix (ASSE 1017)

AngleMix DL 520_AC models are factory-configured with an adjustment limiting set screw, restricting the set temperature to 120 °F meeting ASSE 1070 requirements for scald protection. However, users have the flexibility to convert the valve to an ASSE 1017 style by backing out the limiting set screw, thereby enabling unrestricted adjustment up to 150 °F.

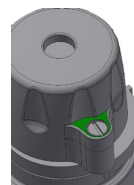

ASSE 1017
(screw up)



ASSE 1070
(screw down)

Check valve

In systems with thermostatic mixing valves, check valves should be installed to prevent undesired backflow. Per ASSE 1070 standard, check valves are required on the hot and cold water supply inlets. As a convenience for easier installations, the Caleffi 520 AngleMix DL thermostatic mixing valves include integral check valves in the hot and cold inlet tailpieces. If the check valves are removed from the tailpieces, ASSE 1070 compliance is voided and the product is not guaranteed to meet performance.

NOTE TO INSTALLER: DO NOT TEST FIT OR INSTALL CHECK VALVES BEFORE SOLDERING. IF INSTALLED, REMOVAL WILL REQUIRE DAMAGING THE CHECK VALVE AND IT WILL NO LONGER BE USABLE.

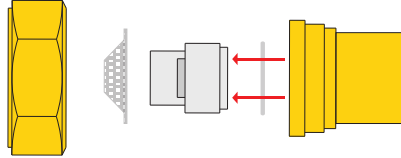

Dimensions

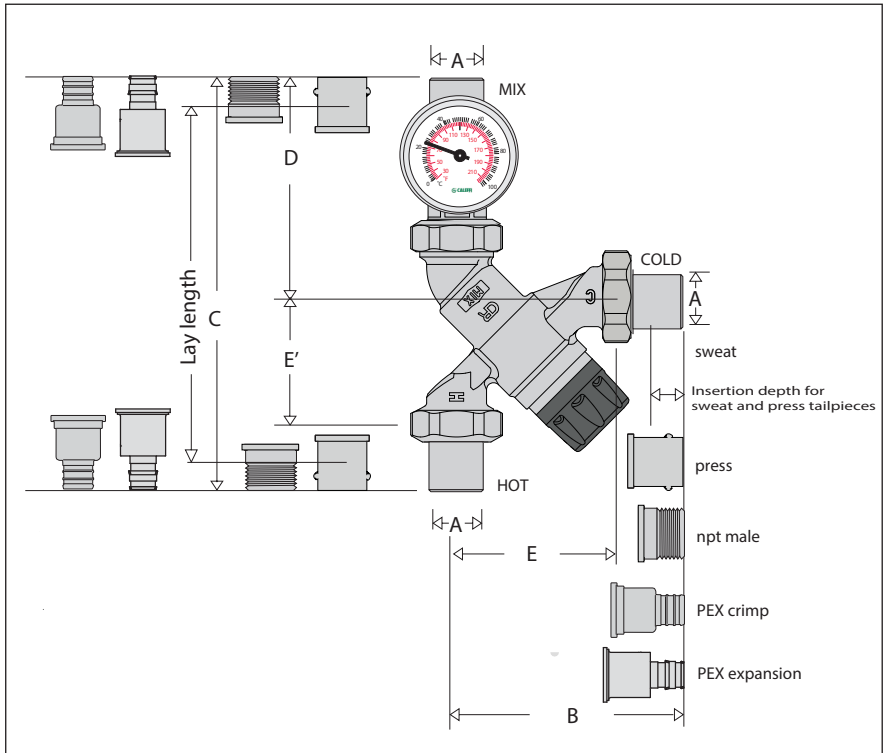

Code	A	B	C	D	E	E'	LL*	Insertion depth	Wt. (lb.)	Cv (Kv)
520410AC	1/2" NPT male	4 1/4"	8 1/4"	4 5/8"	2 1/16"	2 1/16"			1.8	2.0 (1.7)
520414AC	1/2" PEX crimp	4 3/8"	8 9/16"	4 13/16"					1.7	
520415AC	1/2" PEX exp	4 3/8"	8 5/8"	4 7/8"					1.7	
520416AC	1/2" press	4 5/8"	4 1/4"	4 3/16"			6 1/2"	7/8"	1.9	
520419AC	1/2" sweat	4 1/8"	6 3/4"	3 3/16"			5 11/16"	1/2"	1.8	
520510AC	3/4" NPT male	4 3/16"	7 13/16"	4 3/16"					2.1	
520514AC	3/4" PEX crimp	4 3/8"	8 9/16"	4 13/16"					1.9	
520515AC	3/4" PEX exp	4 5/8"	9 1/16"	5 1/16"					1.9	
520516AC	3/4" press	4 11/16"	8 11/16"	4 1/2"			6 3/4"	1 5/16"	2.1	
520519AC	3/4" sweat	4 1/4"	6 15/16"	3 5/16"			5 5/8"	5/8"	2.1	

*Lay length for press tailpieces (hot inlet to mix outlet).

AngleMix DL models with Inlet port check valves included as standard.

Commissioning

The Caleffi AngleMix DL 520 series thermostatic mixing valve must be commissioned in accordance with current standards by qualified personnel using temperature measuring equipment. Caleffi AngleMix DL 520 series come standard with an integral outlet port temperature gauge which provides a time-saving temperature setting process to get close to the desired temperature. Use of a digital thermometer is recommended for confirming the final setting of the mixed water temperature. After installation, the valve must be tested and commissioned in accordance with instructions given below, taking into account current applicable standards.

- 1) Ensure that the system is clean and free from dirt or debris before commissioning the thermostatic mixer.
- 2) It is recommended that the temperature is set using a suitable calibrated digital thermometer. The valve must be commissioned by measuring the temperature of the mixed water emerging at the point of use.
- 3) The maximum outlet temperature from the valve must be set accounting for fluctuations due to simultaneous use. It is essential for these conditions to be stabilized before commissioning.
- 4) Adjust the temperature using the adjusting knob on the valve. For safety reasons, it is advisable to limit the maximum mixed water temperature to 120 °F in domestic hot water systems where anti-scald valves are not located at each fixture.
- 5) The temperature may be adjusted using the control knob.
 - a) Adjust the temperature of the mixed water to the desired value.
 - b) Measure and record the temperature at the cold and hot water inlets.
 - c) Measure and record the temperature of the water delivered from the tap at the lowest and highest flow rates.
 - d) Run a test of the thermal shut-off function. Close the cold water inlet shut-off valve and check the mixed water delivery. The delivery flow rate should quickly drop to zero.
 - e) Measure and record the maximum mixed water temperature. The temperature may not exceed the values permitted in any applicable legislation or code of practice.
 - f) Restore the cold water inlet supply and measure the water delivery temperature after it has stabilized. The final temperature measured in this test may not exceed the permitted values by ± 3 °F (± 2 °C).

In case of change to temperature setting, repeat tests in accordance with points d, e, f. All the above information should be recorded in the commissioning report and updated in the maintenance report whenever the valve is worked on.

Temperature setting and locking

The control knob permits temperature setting between minimum and maximum in one turn (360°). It also has a tamper-proof system to lock the temperature at the set value. The temperature is set to the required value by means of the knob with the graduated scale, on the top of the valve.

Pos.	Min.	1	2	3	4	5	6	7	Max.
T (°F)	95	105	115	120	125	132	140	145	150
T (°C)	35	40	45	48	52	56	60	63	65

with: $T_{HOT} = 158$ °F (70 °C), $T_{cold} = 59$ °F (15 °C), $P = 43$ psi (3 bar)

Gray shading indicates temperature value positions for the AngleMix DL models, limited to 120 °F per ASSE 1070, with setting locking screw in place.

Application diagrams, Point of Distribution

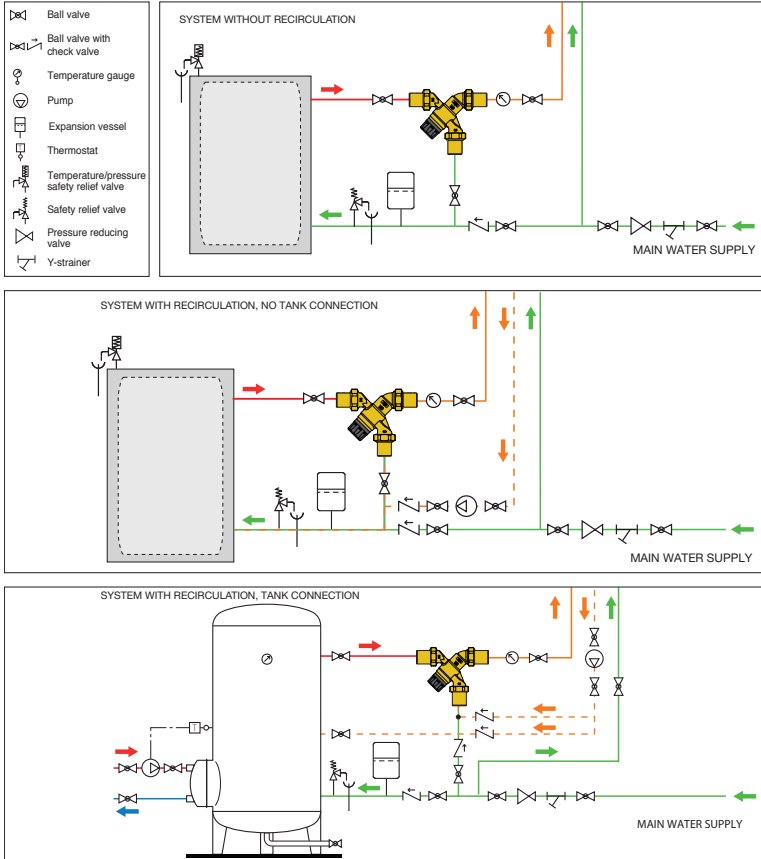

Application diagrams, Point of Use

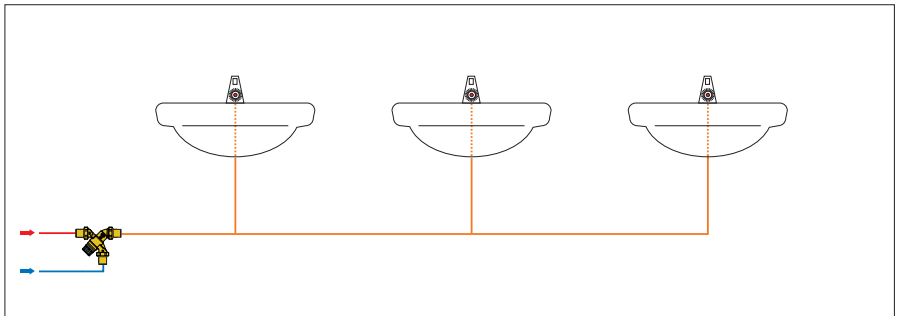
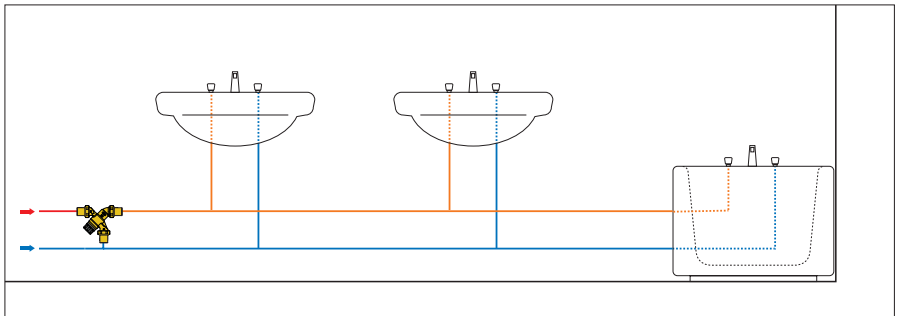
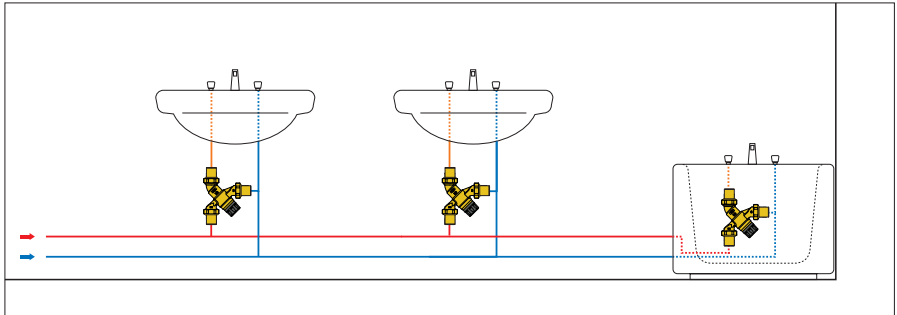

Application diagrams, Point of Use

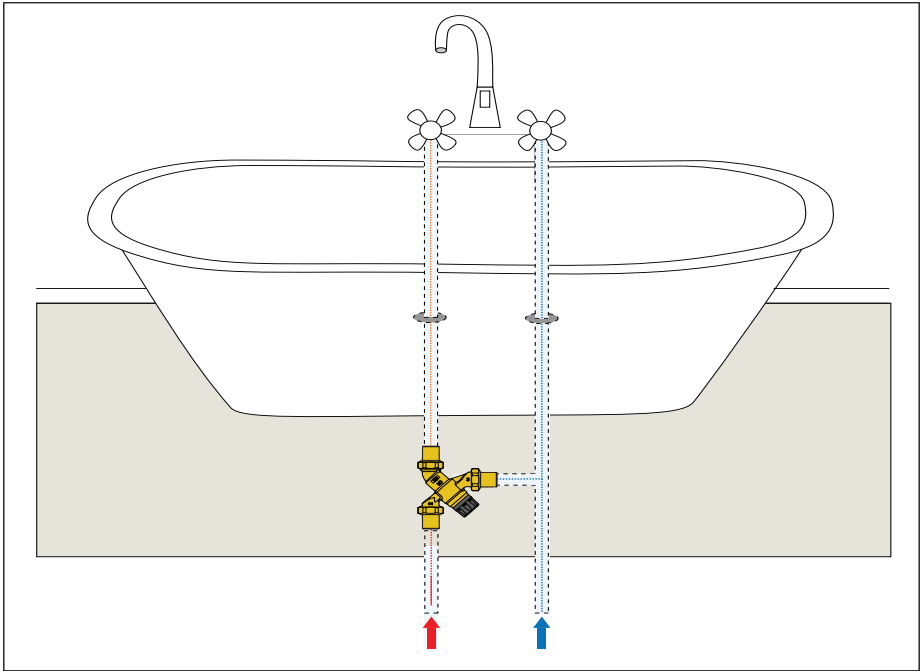

Troubleshooting

Under normal operating conditions the Caleffi AngleMix DL 520 series thermostatic mixing valve will provide a very high level of performance. However, in some circumstances, where the following maintenance schedule is not followed problems may arise.

Recommended maintenance schedule:

Tests should be conducted regularly to monitor the thermostatic mixing valve performance, as deterioration of performance could indicate that the valve and/or the system require maintenance. If, during these tests, the temperature of the mixed water has changed significantly in comparison with the previous test, the details given in the installation and commissioning sections should be checked and maintenance conducted.

The following should be checked regularly to ensure that the optimum performance levels of the valve are maintained. Check every 12 months at least, or more often if necessary.

- 1) Check and clean the system filters.
- 2) Check that any check valves positioned upstream of the Caleffi thermostatic mixing valve are operating correctly, without problems caused by impurities.
- 3) Limescale can be removed from internal components of the thermostatic mixing valve by immersion in a suitable de-scaling fluid.
- 4) When the components which can be maintained have been checked, commission the valve.

Common troubleshooting symptoms:

Symptoms	Cause	Corrective action
Hot water at the cold taps	a) Operation of check valve is hindered; Check valve is not sealing correctly. b) Check valves not installed.	- Replace faulty check valve.
Fluctuating mixed water temperature	a) Erratic supply temperatures at the inlets of the mixing valve. b) Flow through the valve is less than it's minimum flow rate. c) Incorrect commissioning of the valve.	- Restore inlet conditions within the limits of the recirculation circuit.
Erratic flow of water from the valve	a) Flow through the valve is less than it's minimum flow rate. b) Fluctuations in the supply pressures/temperatures. c) Adverse effect created by other draw off points on the system.	- Stabilize inlet supply conditions.
No flow of water from the valve	a) In-line filters or strainers blocked. b) Insufficient supply pressures. c) Debris obstructing valve operation.	- Clean filters or strainers. - Restore inlet supplies. - Clean debris or scale from the valve.
Valve shut-off function not performed when tested	a) Mixing valve not properly installed per instructions. b) Minimum temperature difference not reached. c) Valve mechanism blocked by dirt.	- Re-install per instructions. - Increase hot water temperature. - Remove dirt/limescale from the valve.

NOTES

LEAVE THIS MANUAL WITH THE USER.

Laissez ce manuel à la disposition de l'utilisateur.

04-2024

 **CALEFFI**
Hydronic Solutions
Caleffi North America, Inc.
3883 West Milwaukee Road
Milwaukee, WI 53208
T: 414.238.2360 F: 414.238.2366

**For Technical Support call 1-414-338-6338, or
email techsupport.us@caleffi.com**