

Heat Pump Water Heater

SERVICE MANUAL

CAUTION

BEFORE SERVICING THE UNIT, READ THE SAFETY PRECAUTIONS IN THIS MANUAL.

MODEL : APHWC501M(R5TT50F-SA1), APHWC801M(R5TT80F-SA1)



Any reproduction, duplication, distribution (including by way of email, facsimile or other electronic means), publication, modification, copying or transmission of this Service Manual is **STRICTLY PROHIBITED** unless you have obtained the prior written consent of the LG Electronics entity from which you received this Service Manual. The material covered by this prohibition includes, without limitation, any text, graphics or logos in this Service Manual.

Copyright © 2023 LG Electronics Inc. All rights reserved. Only training and service purposes.



SAFETY PRECAUTIONS

To prevent injury to the user or other people and property damage, the following instructions must be followed.









- Incorrect operation due to ignoring instruction will cause harm or damage. The seriousness is classified by the following indications.



 WARNING This symbol indicates the possibility of death or serious injury.
 CAUTION This symbol indicates the possibility of injury or damage to properties only.







- Meanings of symbols used in this manual are as shown below.

	Be sure not to do.
	Be sure to follow the instruction.
	Dangerous Voltage.





Cautions in Repair







 WARNING	
	Do not turn on the breaker or power under condition that front panel, rear panel, top cover, or control box cover is removed or opened. Otherwise, it may cause fire, electric shock, explosion or death.
	Be sure to disconnect the power to unit before disassembling the equipment for a repair .Internal components and circuit boards are at main potential when the equipment is connected to the power. This high voltage is extremely dangerous and may cause death or severe injury if come in contact with it.
	Do not touch the discharging refrigerant gas during the repair work. The discharging refrigerant gas. The refrigerant gas can cause frostbite.
	Release the refrigerant gas completely at a well-ventilated place first. Otherwise, when the pipe is disconnected, refrigerant gas or refrigerating machine oil discharges and it can cause injury.
	When the refrigerant gas leaks during work, perform ventilation. If the refrigerant gas comes in contact with a fire, poisonous gas generates. A case of leakage of the refrigerant and the closed room full with gas is dangerous because a shortage of oxygen occurs. Be sure to perform ventilation.
	When removing the front panel or cabinet, execute short-circuit and discharge between high voltage capacitor terminals. If discharge is not executed, an electric shock is caused by high voltage resulting in a death or injury.
	Do not use a defective or underrated circuit breaker. Use the correctly rated breaker and fuse. Otherwise there is a risk of fire or electric shock.
	Install the panel and the cover of control box securely. Otherwise there is risk of fire or electric shock due to dust, water etc.

 WARNING	
	Wiring connections must be secured tightly and the cable should be routed properly so that there is no force pulling the cable from the connection terminals. Improper or loose connections can cause heat generation or fire.
	Do not touch, operate, or repair the product with wet hands. Otherwise there is risk of electric shock or fire.

 CAUTION	
	Do not turn on the breaker when the front panel and cabinet are removed.
	Be sure to ground the water heater with an earthing conductor connected to the earthing terminal.
	Conduct repair works after checking that the refrigerating cycle section has cooled down sufficiently. Otherwise, working on the unit, the hot refrigerating cycle section can cause burns.
	Do not tilt the unit while removing panels. Otherwise, the water inside the unit can spill and wet floor.
	Do not use the welder in a well-ventilated place. Using the welder in an enclosed room can cause oxygen deficiency.
	Be sure to turn off power switch before connecting or disconnecting connector, or parts damage may be occur.

Inspections after Repair

 WARNING	
	Check to see if the power cable is not dirty or loose. If the cable is dusty or loose it can cause an electrical shock or fire.
	Do not use a joined power cable or extension cable, or share the same power outlet with other electrical appliances. otherwise, it can cause an electrical shock, excessive heat generation or fire.
	Do not insert hands or other objects through the air inlet or outlet while the product is operating. There are sharp and moving parts that could cause personal injury.
	Do not block the inlet or outlet of air flow. It may cause product failure.

 CAUTION	
	Check to see if the parts are mounted correctly and wires are connected. Improper installation and connections can cause an electric shock or an injury.
	Check whether the installation platform or frame has corroded. Corroded installation platform or frame can cause the unit to fall, resulting in injury.
	Be sure to check whether the earth wire is correctly connected.
	After the work has finished, be sure to do an insulation test to check whether the resistance is 2[Mohm] or more between the charge section and the non-charge metal section (Earth position). If the resistance value is low, a disaster such as a leak or electric shock is caused at user's side.
	Check the drainage of the indoor unit after the repair. If drainage is faulty the water may enter the room and wet floor.

NOMENCLATURE

Factory Model Name

Model	No.										
	1	2	3	4	5	6	7	8	9	10	11
Water Heater	R	5	T	T	5	0	F	-	S	A	1

No.	Signification
1, 2	Heat Pump Water Heater for R134a
3	Classification - T : Packaged
4	Compressor Type - T : Inverter Heating Only
5,6	Water Tank Capacity - e.g. 50gal → "50"
7	Water Tank Capacity - F : Frontier
8	Outdoor Unit Platform - "-" : Packaged(No Outdoor Unit)
9	Look/Color - S : Frontier Silver
10	Function - A : Smart Function + Hybrid Mode
11	Serial No. - LG Model Development Serial No.

Buyer Model Name

Refrigerant	Series	No								
		1	2	3	4	5	6	7	8	9
R134A	1	A	P	H	W	C	5	0	1	M

No.	Signification
1	Refrigerant - A: R134A
2	Component - P : Packaged
3	Product Category - H: Heating
4	Product Type - W : Tank Water
5	Product Grade - C : Standard Efficiency
6, 7	Nominal Capacity - e.g. 50gal → "50"
8	Generation
9	Features - M : Mid Temp. Water

PRODUCT SPECIFICATIONS

Model			APHWC501M	APHWC801M
Capacity	Volume(Nominal)	Gal	58	80
		L	220	303
	Volume(Rated)	Gal	53	72
		L	201	273
	UEF(Draw Pattern Medium)	-	-	-
	UEF(Draw Pattern High)	-	3.93	3.90
	FHR	Gal	76	94
	Annual Energy Consumption	kWh	1262	1272
Power Input	Upper Element Wattage(208V / 240V)	kW	3.8 / 5.0	3.8 / 5.0
	Lower Element Wattage(208V / 240V)	kW	3.8 / 5.0	3.8 / 5.0
Energy Star		-	Yes	Yes
Power Supply		Ø, V, Hz	1Ø,208/240V,60Hz	1Ø,208/240V,60Hz
Available Voltage Range		V	176~276	176~276
Air Flow Rate	Rated	CFM	155.4	155.4
Sound Pressure Level	Auto	dB(A)	42	42
	Turbo/Heat Pump	dB(A)	45	45
Dimensions	Net(W x H x D)	in.	22-27/32 x 63-31/32 x 22-29/32	22-27/32 x 79-1/16 x 22-29/32
	Shipping(W x H x D)	in.	29-1/16 x 69-7/8 x 27-5/32	29-1/16 x 84-31/32 x 27-5/32
Weight	Net	lb.	220	262
	Shipping	lb.	260	304
Operation Range	Heating	°F DB	23 ~ 120	23 ~ 120
Exterior Color		-	Luxury Silver	Luxury Silver
Compressor	Type	-	Twin Rotary	Twin Rotary
	Model	-	EST092MBA	EST092MBA
	Motor Type	-	BLDC	BLDC
	Locked Rotor Ampere(LRA)	A	N/A(Inverter)	N/A(Inverter)
	Oil Type	-	POE PVE	POE PVE
	Oil Charge	cc	220	220
	Rated Load Ampere(208V / 240V)	A	3.3 / 3.1	3.3 / 3.1

Model			APHWC501M	APHWC801M
Fan	Type	-	Propeller Fan	Propeller Fan
	Motor Type	-	BLDC	BLDC
	Motor Output	-	43	43
	Full Load Ampere(FLA)	-	0.22	0.22
Heat Ex changer(Evaporator)	Quantity	-	1	1
	Rows	-	3	3
	Columns	-	15	15
	FPI	-	21	21
Design Pressure(System)	High Side	psi	290	290
	Low Side	psi	130.5	130.5
Max Working Pressure(Water Tank)		psi	150	150
Minimum Circuit Ampacity		A	30.1	30.1
Maxium Circuit Breaker	Heat Pump & Heater	A	30	30
Wiring Connections	Power Supply Cable(included Earth)	AWG x cores	10 x 3C	10 x 3C
Drain Hose Size	I.D	in.	3/4, 1/2	3/4, 1/2
Refrigerant	Type	-	R134a	R134a
	Pre Charge	oz.	23	26
	Additional Charge	oz./ft.	-	-
	Control	-	Electronic Ex pansion Valve	Electronic Ex pansion Valve
Defrost Method		-	Reverse Cycle	Reverse Cycle
Anode		-	Sacrificial	Sacrificial
Foam Insulation		inch	1.6 ~ 2.4	1.6 ~ 2.4
T&P Relief Valve		-	Yes	Yes
Water Connection Location		-	Side	Side
Water Connection Size		inch	3/4	3/4
Digital Display		-	Yes	Yes
Wi-Fi		-	Yes	Yes

PIPING DIAGRAM

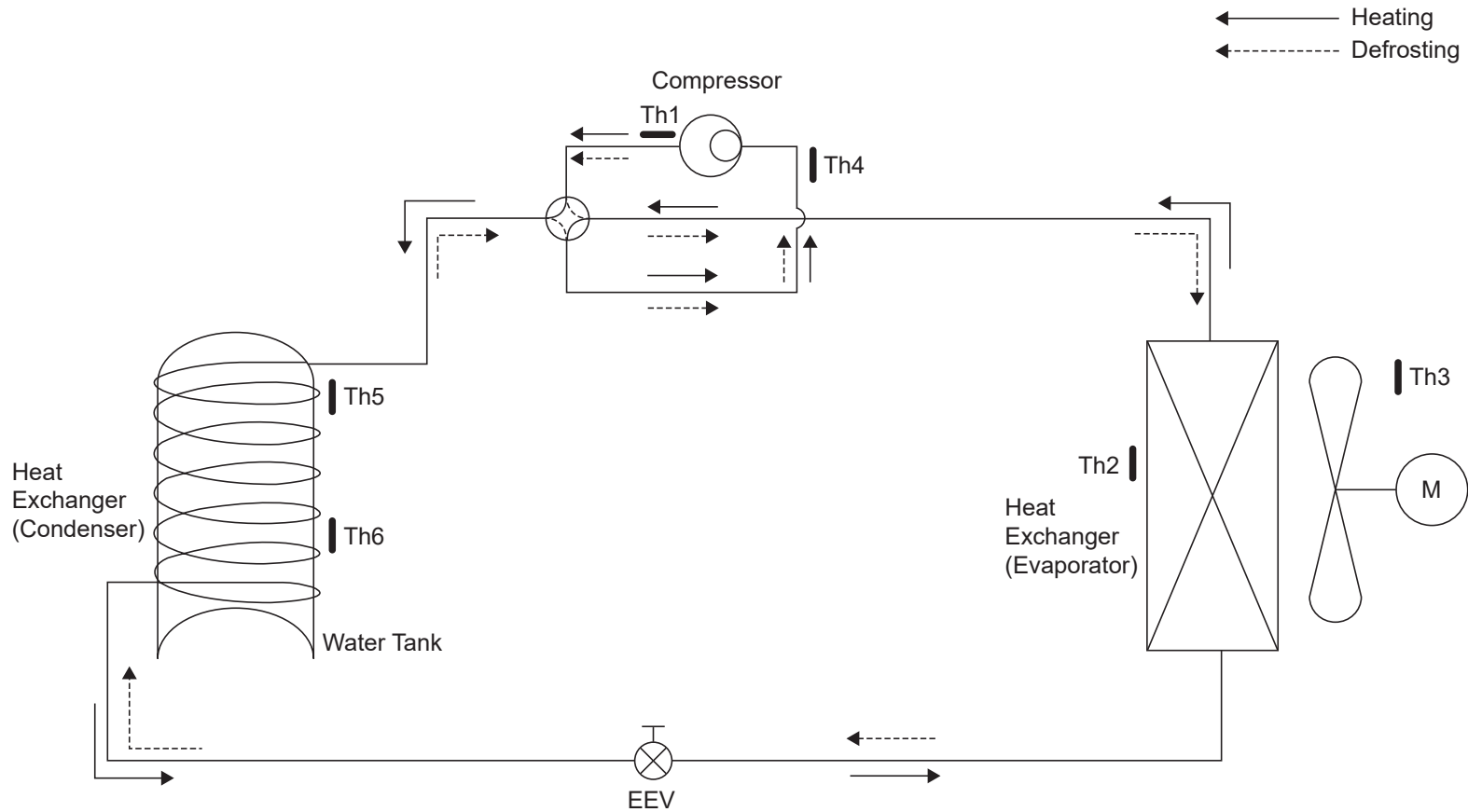

LOC	Description	PCB Connector
Th1	Thermistor for discharge pipe temperature	CN_TH2
Th2	Thermistor for evaporating temperature	CN_TEMP_AIR
Th3	Thermistor for indoor air temperature	CN_TEMP_AIR
Th4	Thermistor for suction pipe temperature	CN_TH1
Th5	Thermistor for upper water tank temperature	CN_TANK_D
Th6	Thermistor for lower water tank temperature	CN_TANK_U

*EEV : Electronic Expansion Valve.

WIRING DIAGRAM

APHWC501M / APHWC801M

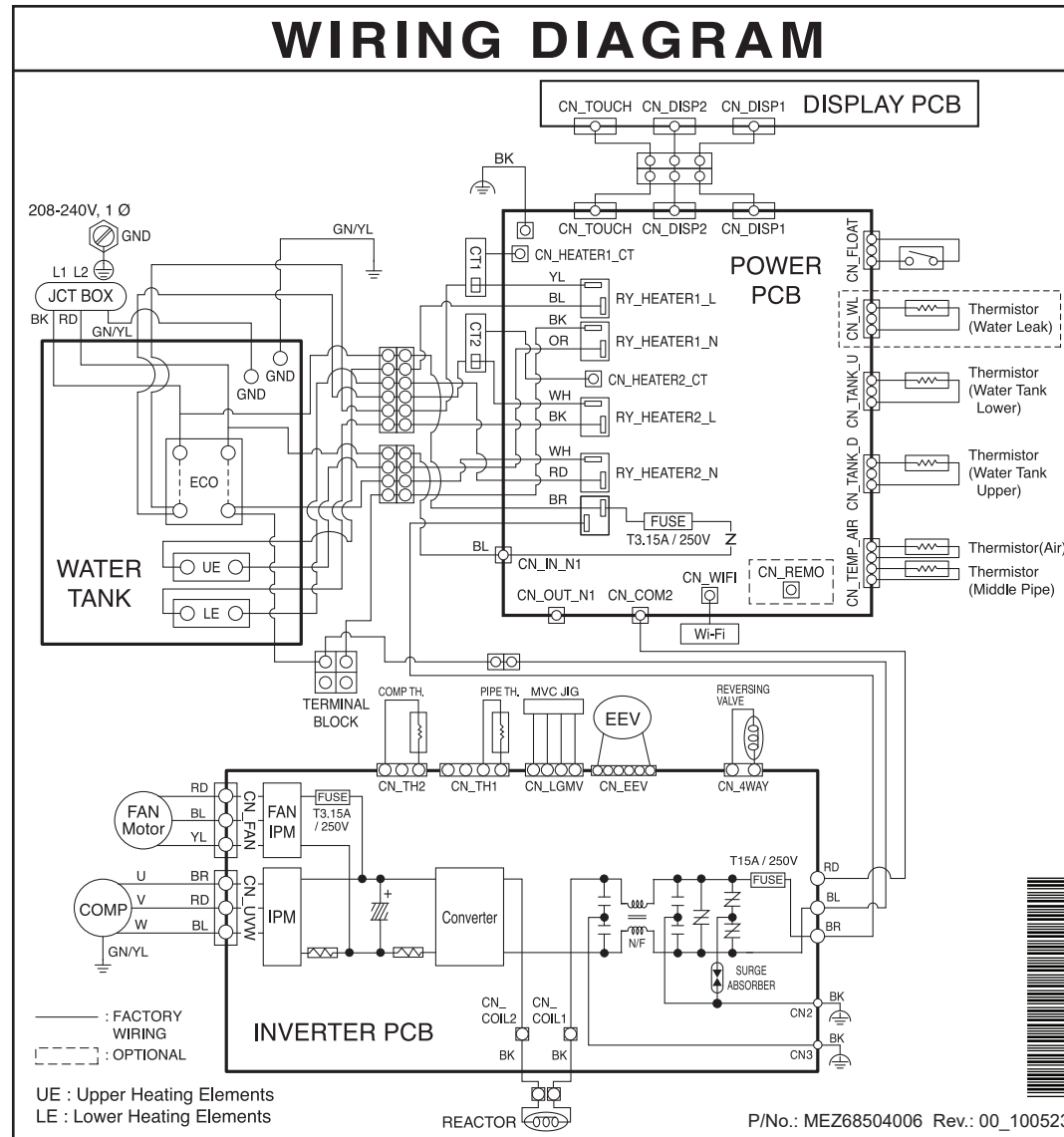

APHWC501M / APHWC801M

POWER PCB

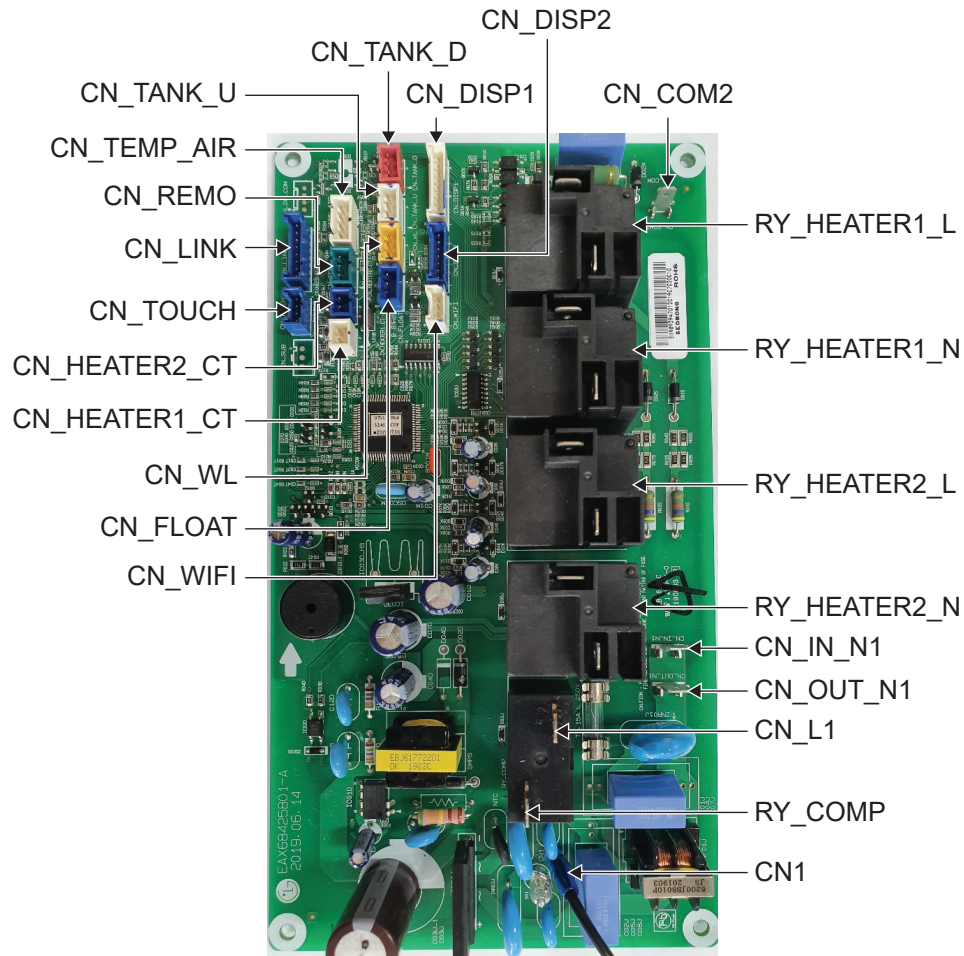

INVERTER PCB

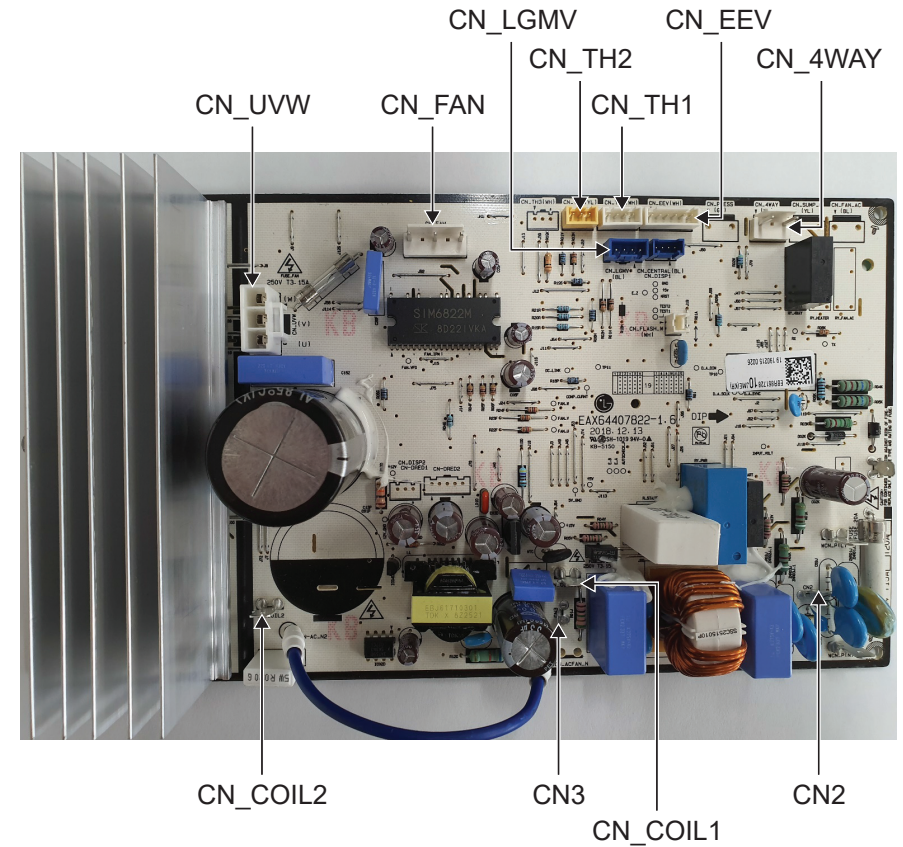

EXPLODED VIEW

MODEL:

Customer Model	APHWC501M
	APHWC801M

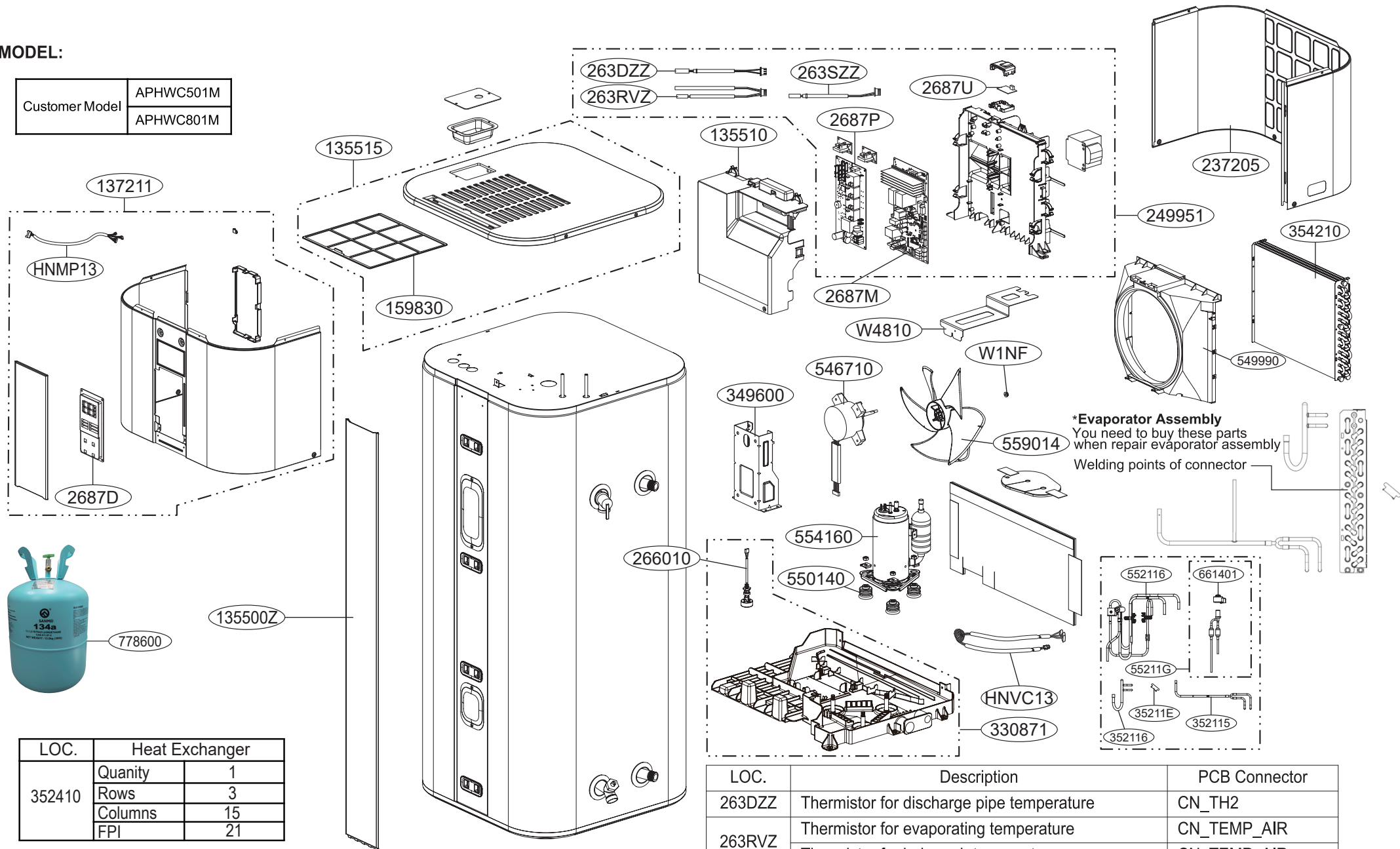

***Evaporator Assembly**
 You need to buy these parts
 when repair evaporator assembly
 Welding points of connector

LOC.	Heat Exchanger	
352410	Quantity	1
	Rows	3
	Columns	15
	FPI	21

LOC.	Description	PCB Connector
263DZZ	Thermistor for discharge pipe temperature	CN_TH2
263RVZ	Thermistor for evaporating temperature	CN_TEMP_AIR
	Thermistor for indoor air temperature	CN_TEMP_AIR
263SZZ	Thermistor for suction pipe temperature	CN_TH1

DISASSEMBLY

Before the following disassembly, disconnect all power to the heater and shut off the water supply to the heater.

1. Top cover and Front panel

- Remove the 6 screws that fasten the top cover. (See Figure 1)
- Remove the top cover.
- Remove the front décor. (There are 4 hooks.)
- Remove the 4 screws that fasten the front panel. (See Figure 2)
- Lift the front panel out. (Lift right side first.)
- Disconnect the connector between the front panel and control box.
- Re-install the components by referring to the removal procedure, above.

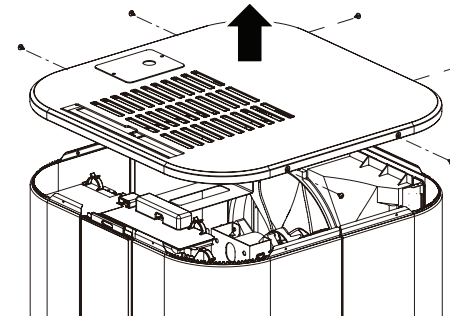

(Figure 1)

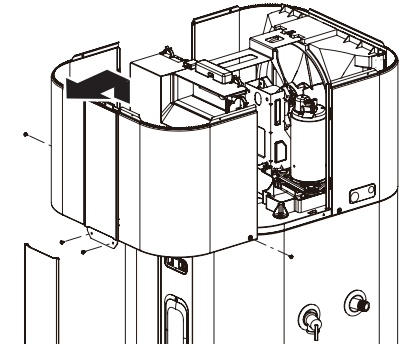

(Figure 2)

2. Rear panel

- Remove the top cover and front panel. (Refer to section 1)
- Remove the 2 screws that fasten the rear panel at both sides.
- Remove the 2 screws that fasten the rear panel at back.
- Lift the rear panel out. (See Figure 3)
- Re-install the components by referring to the removal procedure, above.

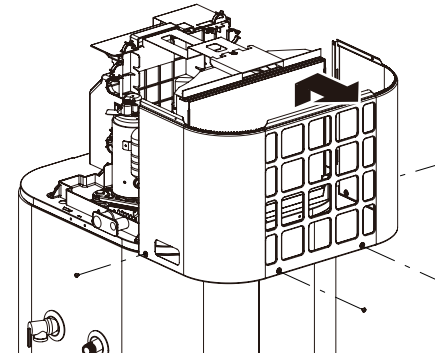

(Figure 3)

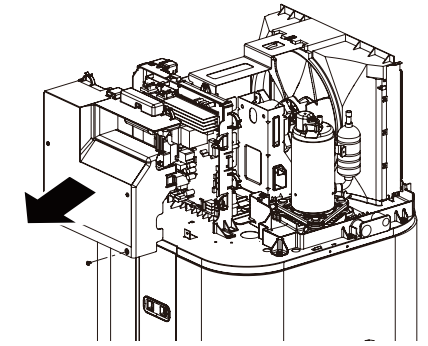

(Figure 4)

3. Control box

- Remove the top cover and front panel. (Refer to section 1)
- Remove the 1 screw that fasten the control box cover.
- Remove the control box cover. (There are 3 hooks.) (See Figure 4)
- Re-install the components by referring to the removal procedure, above.

4. Motor and Fan

- Remove the top cover, front panel, and rear panel. (Refer to section 1, 2)
- Remove the 2 screws that fasten the bracket. (See Figure 5)
- Remove the bracket.
- Remove the 4 screws that fasten the motor bracket.
- Lift out the motor bracket, motor, and fan. (See Figure 6)
- Remove the 2 screws and the nut that secure the motor and fan.
- Separate the motor bracket, motor, and fan.
- Re-install the components by referring to the removal procedure, above.

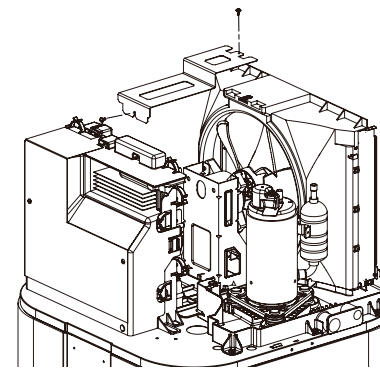

(Figure 5)

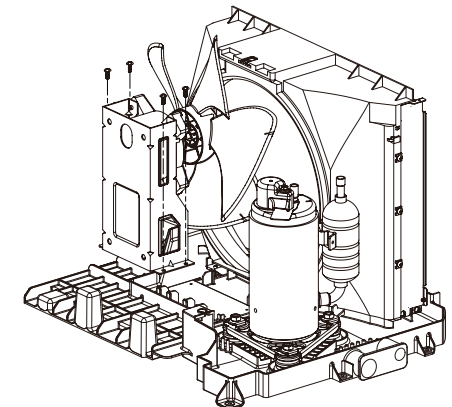

(Figure 6)

5. Shroud

- Remove the fan. (Refer to section 4)
- Remove the 6 screws that fasten the shroud.
- Remove the shroud. (See Figure 7)
- Re-install the components by referring to the removal procedure, above.

6. Heating Elements

- Drain the water heater to a level just below the element to be replaced.
- Remove the front décor. (There is 4 hooks.)
- Remove 2 screws that fasten the element cover.
- Remove the element cover. (See Figure 8)
- Mark, then disconnect the wires from the element by removing the 2 screws.
- Using socket wrench, remove the element.
- Re-install the components by referring to the removal procedure, above.

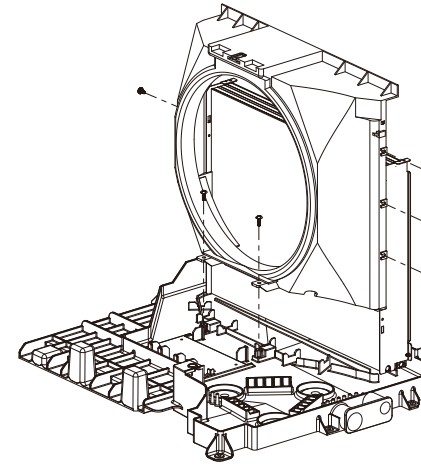

(Figure 7)

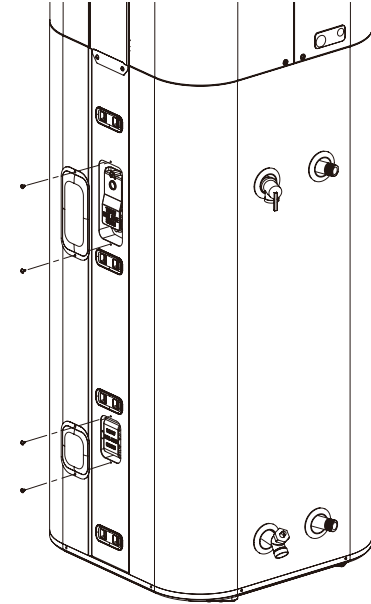

(Figure 8)

7. ECO

- Drain the water heater to a level just below the upper element
- Remove the front decor. (There is 4 hooks.)
- Remove 2 screws that fasten the upper element cover. (See Figure 8)
- Remove the upper element cover.
- Mark, then disconnect the wires from the ECO by removing the 4 screws.
- Remove 2 nuts that fasten the ECO.
- Remove the ECO.
- Re-install the components by referring to the removal procedure, above.

