

# INSTALLATION INSTRUCTIONS

## Gas Changeover Kit

Natural to Regulated LP/Propane (Kit #11K50)

For A80, 80G1, A93, A95, 92G1, 95G1 and 96G1 Units

This manual must be left with the homeowner for future reference.

### ▲ WARNING

In the U.S., this conversion kit is to be installed by a licensed professional service technician (or equivalent) or other qualified agency in accordance with the manufacturer's instructions and all codes and requirements of the authority having jurisdiction. If the information in these instructions is not followed exactly, a fire, an explosion, or production of carbon monoxide may result, causing property damage, personal injury or loss of life. The qualified agency is responsible for the proper installation of the kit. The installation is not proper and complete until the operation of the converted furnace is checked as specified in the furnace manufacturer's instructions supplied with the kit.

### Shipping and Packing List

Package 1 of 1 contains:

- 12 -Main burner orifices (0.034)
- 1 - Gas converter sticker
- 1 - Nameplate conversion sticker
- 1 - Bag assembly containing:
  - 1- Gas valve regulator spring
  - 1- Low gas inlet pressure switch
  - 1- Gas valve inlet brass fitting
  - 1- Wiring harness

Check the kit for shipping damage. If you find any damage, immediately contact the last carrier.

### Application

Use natural to LP/Propane gas conversion kit 11K50 to convert units from natural gas to LP/Propane.

### Installation

#### ▲ CAUTION

As with any mechanical equipment, personal injury can result from contact with sharp sheet metal edges. Be careful when you handle this equipment.

#### ▲ CAUTION

Gas valve conversion kit MUST be installed BEFORE the unit is fired using LP/propane gas. Unit damage WILL OCCUR if the unit is fired using LP/propane gas with the original natural gas orifices.

1. Set the thermostat to the lowest setting. If the gas supply line has been connected, shut off the gas supply to the furnace, then disconnect the electrical power.

Manufactured By  
**Allied Air Enterprises LLC**  
A Lennox International, Inc. Company  
215 Metropolitan Drive  
West Columbia, SC 29170



(P) 507369-03

Save these instructions for future reference

2. Remove the heating compartment access panel. Turn the automatic gas valve switch to the OFF position. See Figure 2 and Figure 3.
3. Disconnect the gas supply and the two wires at the gas valve.
4. Remove the burner box cover (if equipped). Remove the four manifold securing screws. Slide the manifold/gas valve assembly out of the burner box.
5. Replace the burner orifices with the provided gas orifices. Torque to approximately 35 in-lbs. Do not use sealant on orifices. Figure 4 and Figure 5 show manifold/gas valve assembly.

**▲ IMPORTANT**

DO NOT use pipe dope or any pipe sealant on gas orifice threads.

6. Replace the gas valve regulator spring with the provided regulator spring. See Figure 6.
7. A80 and 80G1 units with Nox inserts being converted from natural to LP /Propane.
  - a. Remove the burner box assembly from the vestibule panel.
  - b. Remove the screws which secure each of the NOx inserts to the clamshell. Remove the NOx inserts and reinstall the screws. See Figure 1.
  - c. Re-install burner box assembly.

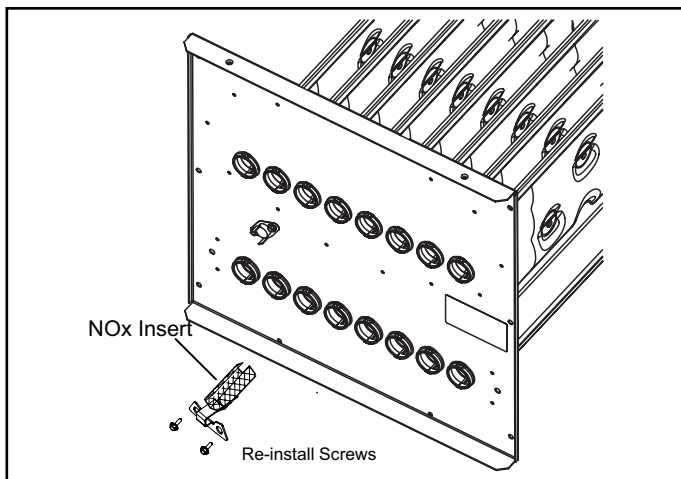

**Figure 1. NOx Inserts**

8. Re-install the manifold/valve assembly.
9. Thread provided brass fitting to gas valve inlet until hand tight. Using properly sized wrench, tighten fitting 2 to 3 full turns being careful to position the side port to allow clearance for the pressure switch and harness. See Figure 2.

**NOTE:** Never use channel lock pliers or a pipe wrench on the brass fitting.

**NOTE:** Some installations may require the pressure switch and fitting assembly to be positioned differently than shown in Figure 2.

10. Thread the gas supply to the brass fitting until hand tight. Using properly sized wrench to support brass fitting, tighten supply line into fitting 2 to 3 full turns to achieve leak free joint.

**NOTE:** Do not over tighten. (Maximum 3 full turns past hand tight for 1/2" NPT per ASME B1.20.1-2013)

11. Thread pressure switch to brass fitting 2 to 3 turns past hand tight, then wire as shown in Figure 7.
12. Restore the electrical power to the unit.
13. Inspect all sides of assembly. Turn on gas supply. **Immediately check the entire fitting surface and assembly joints for gas leaks.**
14. Affix nameplate conversion sticker next to unit nameplate.
15. Complete the information required on the gas converter sticker: date, name, and address. Affix sticker to the exterior of the unit in a visible area.
16. Follow the steps given in the start-up and adjustment section.

**▲ IMPORTANT**

Carefully check all piping connection for gas leaks. DO NOT use matches, candles, open flames or other means of ignition to check for gas leaks. Use a soap solution or other preferred means.

**▲ CAUTION**

Some soaps used for leak detection are corrosive to certain metals. Carefully rinse piping thoroughly after leak test has been completed. Do not use matches, candles, flame or other sources of ignition to check for gas leaks.

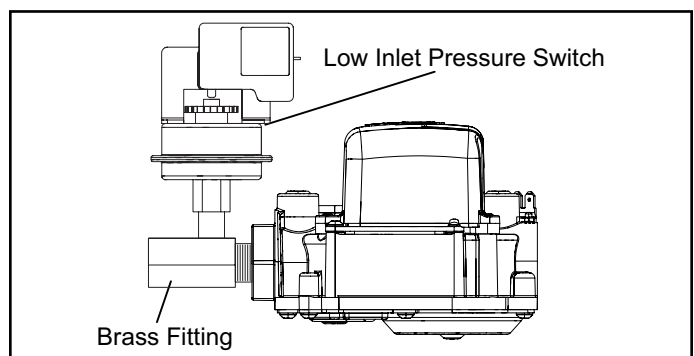

**Figure 2. Gas Valve with Low Inlet Pressure Switch Location**

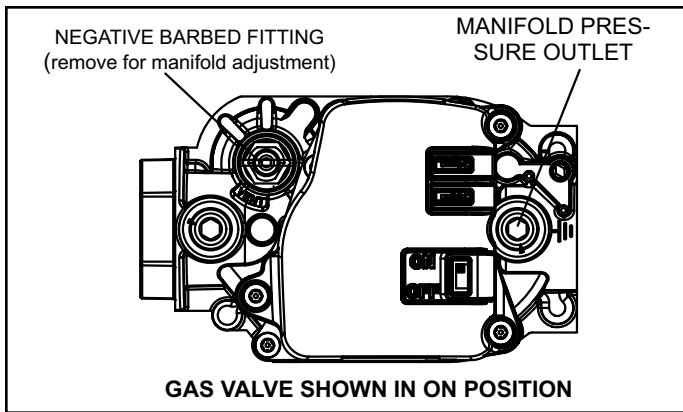

Figure 3. Gas Valve

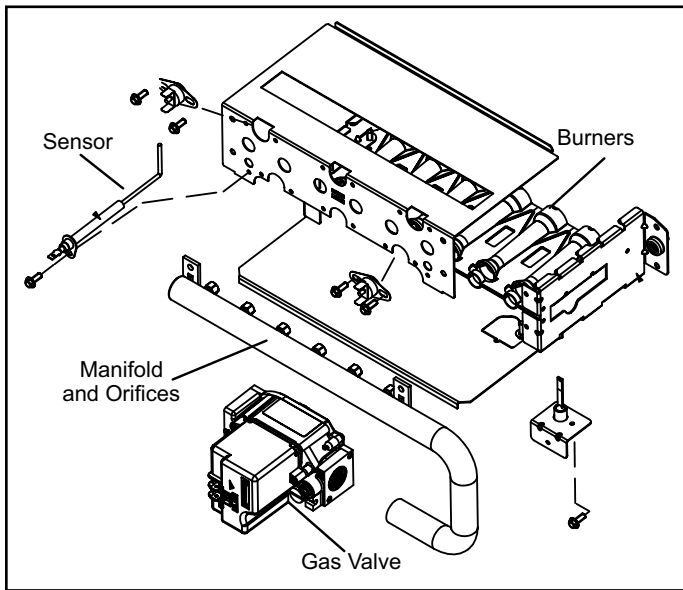

Figure 4. Manifold Gas Valve Assembly (A93, A95, 92G1, 95G1 & 96G1)

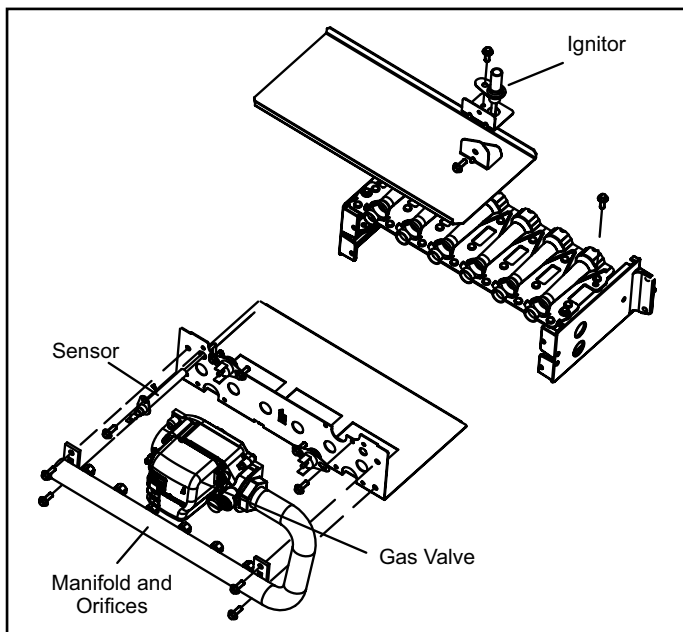

Figure 5. Manifold Gas Valve Assembly (A80 & 80G1)

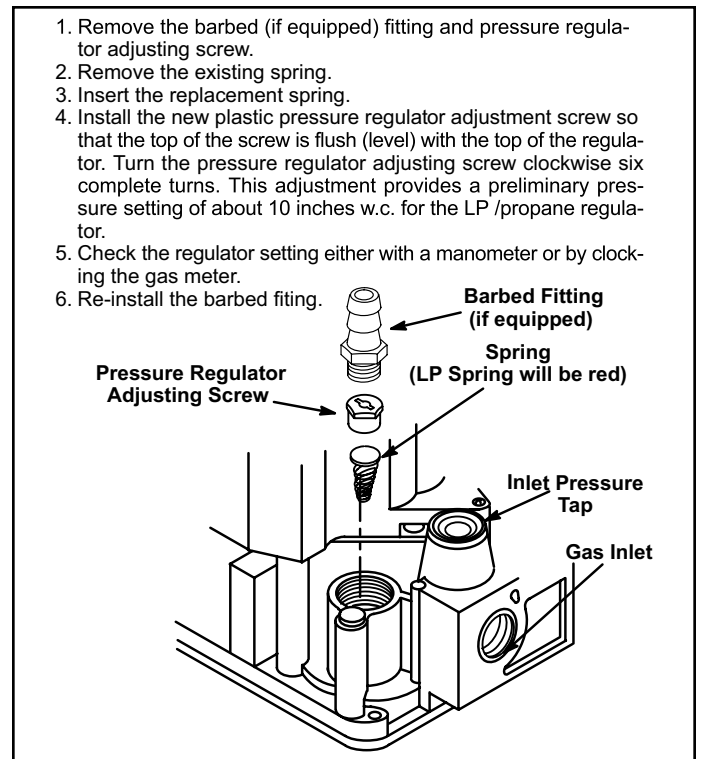

Figure 6. Conversion of Gas Valve

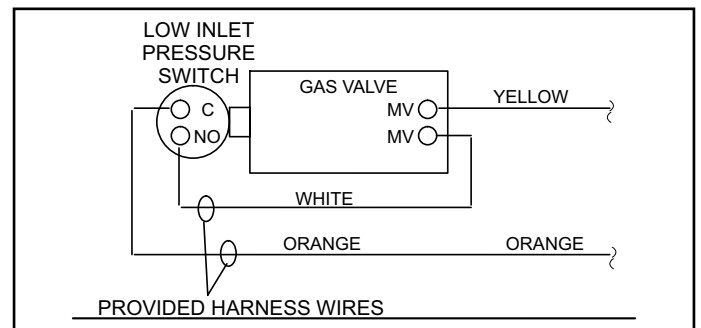

Figure 7. Low Inlet Pressure Switch Wiring Point-to-Point Wiring Diagram

### Start-Up & Adjustment

**BEFORE LIGHTING** - Smell all around the appliance area for gas. Be sure to smell next to the floor because LP/ Propane gas is heavier than air and will settle on the floor.

Use only your hand to move the gas control switch. Never use tools. If the switch will not move by hand, do not try to repair it. Force or attempted repair may result in a fire or explosion.

## Placing the Unit into Operation

### ▲ IMPORTANT

Follow the lighting instructions provided on the unit. If lighting instructions are not available, refer to the following section.

Units are equipped with a hot surface ignition system. The ignition system automatically lights the burners each time the thermostat calls for heat.

- STOP!** Read the safety information at the beginning of this section.
- Set the thermostat to its lowest setting.
- Turn off all electrical power to the furnace.
- Do not try to light the burners by hand.
- Remove the unit access panel.
- Move gas valve switch to **OFF**. See Figure 3.
- Wait five (5) minutes for any gas to clear out. If you then smell gas, **STOP!** Immediately call your gas supplier from a neighbor's phone. Follow the gas supplier's instructions. If you do not smell gas, go to the next step.
- Move gas valve switch to **ON**. See Figure 3.
- Replace the unit access panel.
- Turn on all electrical power to the unit.
- Set the thermostat to desired setting.
- If the furnace will not operate, see the section "Turning Gas Off to the Unit" and call your the gas supplier.

## Gas Pressure Measurement Gas Flow (Approximate)

Capacity	Seconds for One Revolution			
	Natural		LP	
	1 cu ft Dial	2 cu ft Dial	1 cu ft Dial	2 cu ft Dial
-045	80	160	200	400
-070	55	110	136	272
-090	41	82	102	204
-110	33	66	82	164
-135	27	54	68	136
Natural - 1000 btu/cu ft			LP - 2500 btu/cu ft	

**Table 1. Gas Meter Clocking Chart**

Furnace should operate at least 5 minutes before checking gas flow. Determine time in seconds for **two** revolutions of gas through the meter. (Two revolutions assures a more accurate time.) **Divide by two** and compare to time in Table 1. If manifold pressure matches Table 2 and rate is incorrect, check gas orifices for proper size and restriction. Remove temporary gas meter if installed.

## Supply Pressure Measurement

When testing supply gas pressure, use the 1/8" N.P.T. supply line tap located on the gas valve to facilitate test gauge connection. See Figure 2. Check gas line pressure with unit firing at maximum rate. Low pressure may result in erratic operation or underfire. High pressure can result in permanent damage to gas valve or overfire.

On multiple unit installations, each unit should be checked separately, with and without units operating. Supply pressure must fall within range listed in Table 2.

**NOTE:** To obtain accurate reading, shut off all other gas appliances connected to meter.

## Manifold Pressure Measurement

- Connect test gauge to manifold pressure tap (Figure 2) on gas valve.
- Start unit and allow 5 minutes for unit to reach steady state.
- After allowing unit to stabilize for 5 minutes, record manifold pressure and compare to value given in Table 2.
- If necessary, make adjustments. Figure 2 shows location of adjustment screw.

Capacity	Manifold Pressure in. w.g. 0 - 7500 ft.	Supply Line Pressure in. w.g.	
		Min	Max
All Models	10.0	11.0	13.0

**Table 2.**

## Proper Combustion

Furnace should operate minimum 15 minutes with correct manifold pressure and gas flow rate before checking combustion. Take combustion sample beyond the flue outlet and compare to Table 3.

**NOTE:** Shut unit off and remove manometer as soon as the supply pressure, manifold pressure and combustion sample have been obtained. Take care to remove barbed fitting and replace threaded plug.

Model	CO <sub>2</sub> % for LP
All A93, A95, 92G1, 95G1 & 96G1 Units	8.4 - 9.6
All A80 & 80G1 Units	7.5 - 9.0
The carbon monoxide reading should not exceed 100 ppm.	

**Table 3.**

## Turning Off Gas to the Unit

- Set the thermostat to its lowest setting.
- Turn off all the electrical power to the unit.
- Remove the access panel.
- Move the switch on the gas valve to **OFF**. Do not force the switch.