

INSTALLATION INSTRUCTIONS

Gas Changeover Kit

Natural to Regulated LP/Propane (Kit #11K48)

For Two-Stage Gas Products

80(A,G2,NF*S,G*M,B*G) 92/93/95/96/97(A,G2,NF*S,G*T,B*G)

This manual must be left with the homeowner for future reference.



This is a safety alert symbol and should never be ignored. When you see this symbol on labels or in manuals, be alert to the potential for personal injury or death.

▲ WARNING

In the U.S., this conversion kit is to be installed by a licensed professional service technician (or equivalent) or other qualified agency in accordance with the manufacturer's instructions and all codes and requirements of the authority having jurisdiction. If the information in these instructions is not followed exactly, a fire, an explosion, or production of carbon monoxide may result, causing property damage, personal injury or loss of life. The qualified agency is responsible for the proper installation of the kit. The installation is not proper and complete until the operation of the converted furnace is checked as specified in the furnace manufacturer's instructions supplied with the kit.

Shipping and Packing List

Package 1 of 1 contains the following:

- 2 - White Rodgers LP/Propane regulator springs (77W89)
- 2 - Resideo LP/Propane regulator springs (23Y44)
- 12 -Main burner orifices (0.034)
- 1 - Gas converter sticker
- 1 - Nameplate conversion sticker
- 1 - Low gas inlet pressure switch
- 1 - Gas valve inlet fitting
- 1 - Wire harness

Application

Use natural to LP gas conversion kit 11K48 to convert two-stage gas furnaces from natural gas to regulated LP/Propane.

Installation

▲ CAUTION

As with any mechanical equipment, personal injury can result from contact with sharp sheet metal edges. Be careful when you handle this equipment.

1. Set the thermostat to the lowest setting. Shut off the gas supply to the furnace, then turn off the electrical power at the unit disconnect switch.

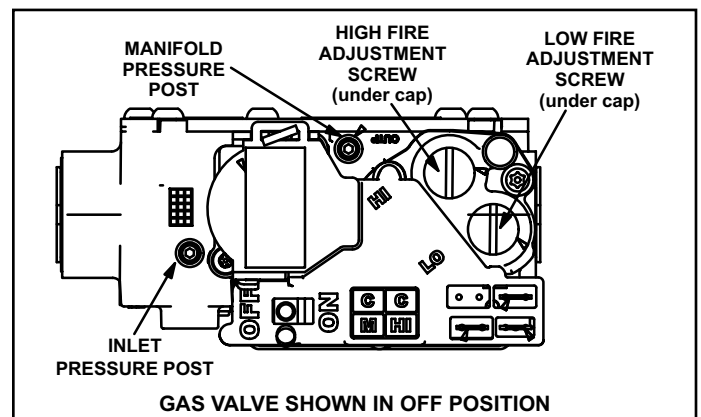

Figure 1. White Rodgers Gas Valve



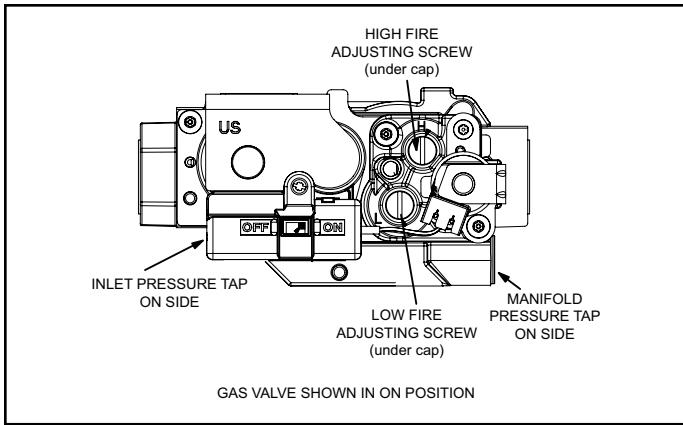

Figure 2. Resideo Two-Stage Gas Valve

2. Remove the access panel. Move the automatic gas valve switch to OFF. See Figure 1 or Figure 2.
3. Disconnect the gas supply from the gas valve. Disconnect the wiring harness at the gas valve.
4. Remove the screw that secures the burner box front cover and remove front cover. See Figure 3 or Figure 4.
5. Remove the four manifold securing screws. Remove the manifold/gas valve assembly. Replace the burner orifices with those provided. Torque to 75-90 in-lbs. Do not use thread sealant. See Figure 3 or Figure 4.

NOTE: LP/Propane orifices will be labeled (LP .034).

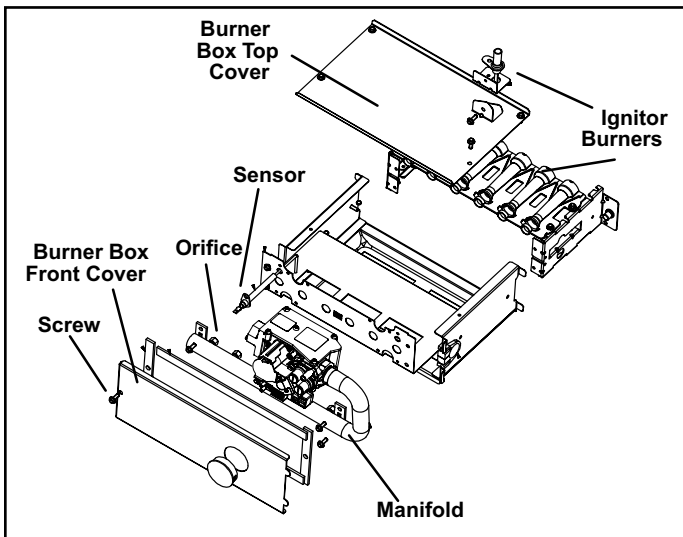

Figure 3. 80% Two-Stage Burner Box

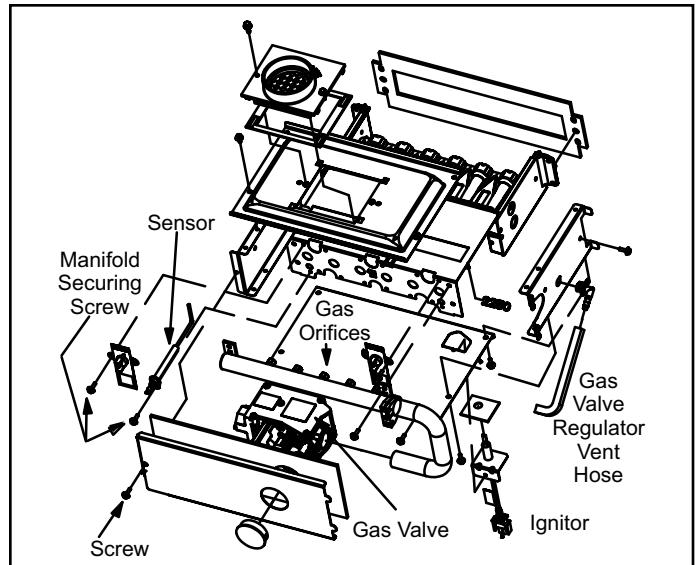

Figure 4. 90% Two-Stage Burner Box

▲ IMPORTANT

DO NOT use pipe dope or any pipe sealant on gas orifice threads.

6. Gas Valve Conversion
 - a. Remove both high fire and low fire springs from the gas valve. See Figure 5 or Figure 6.
 - b. Replace both high fire and low fire springs with the provided LP springs color-coded white.
 - c. Install the high fire adjustment screw and adjust approximately 12 turns.
 - d. Install the low fire adjustment screw and adjust approximately 8 turns.
 - e. Install both regulator screw covers.

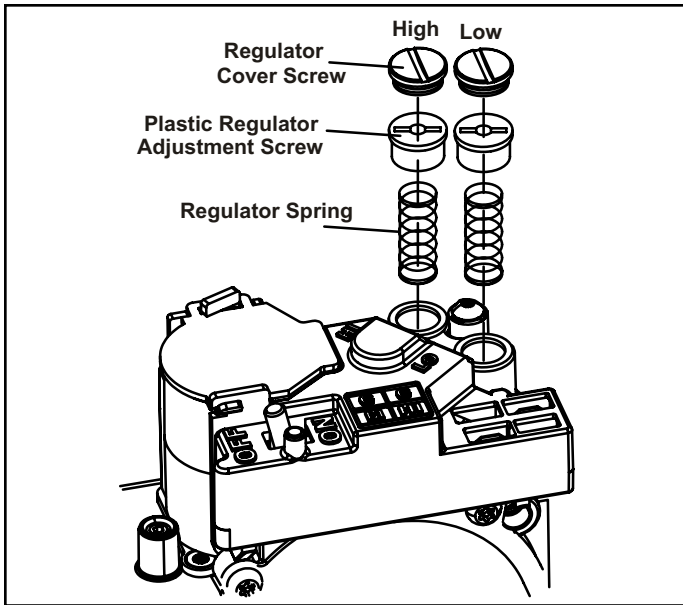

Figure 5. Remove Springs from White Rodgers Gas Valve

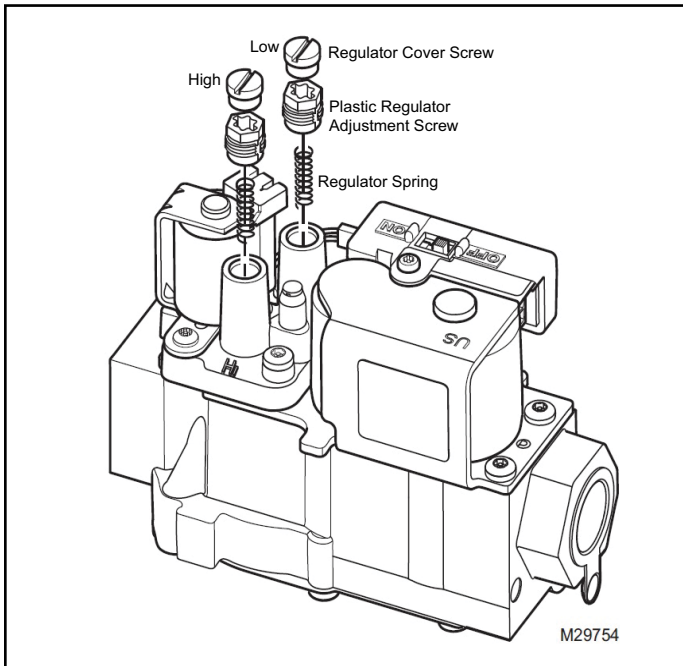

Figure 6. Remove Springs from Resideo Gas Valve

7. 80% two-stage units with Nox inserts being converted from natural to LP/Propane.
 - a. Remove the burner box assembly from the vestibule panel.
 - b. Remove the screws which secures each of the NOx inserts to the clamshell. Remove the NOx inserts and reinstall the screws. See Figure 7.
 - c. Re-install burner box assembly.
8. Re-install the manifold/valve assembly.

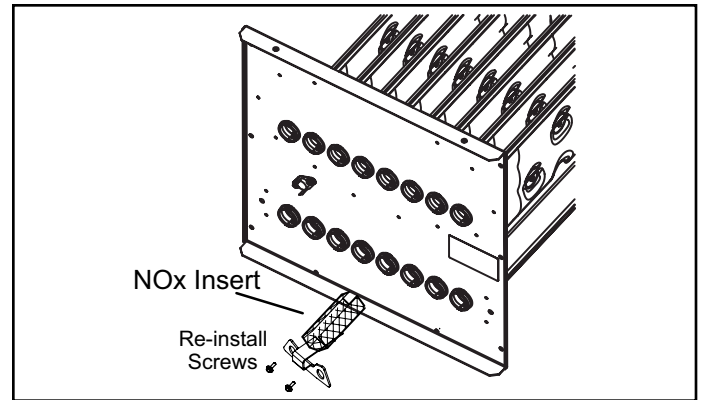

Figure 7. NOx Inserts

9. Thread provided fitting to gas valve inlet until hand tight. Using properly sized wrench, tighten fitting 2 to 3 full turns being careful to position the side port to allow clearance for the pressure switch and harness. See Figure 8 through Figure 11.

NOTE: Never use channel lock pliers or a pipe wrench on the fitting.

NOTE: Some installations may require the pressure switch and fitting assembly to be positioned differently than shown in Figure 8 through Figure 11.

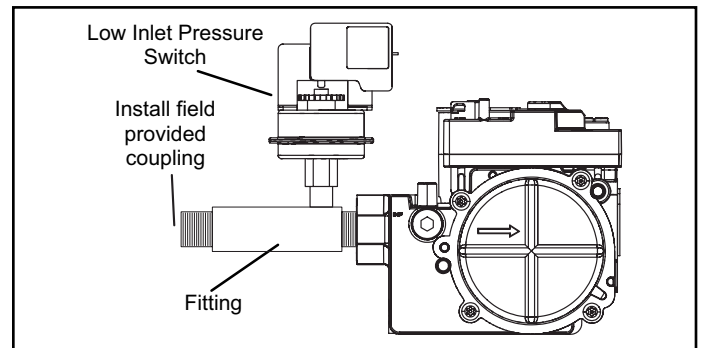

Figure 8. Thread Gas Supply (White Rodgers Gas Valve)

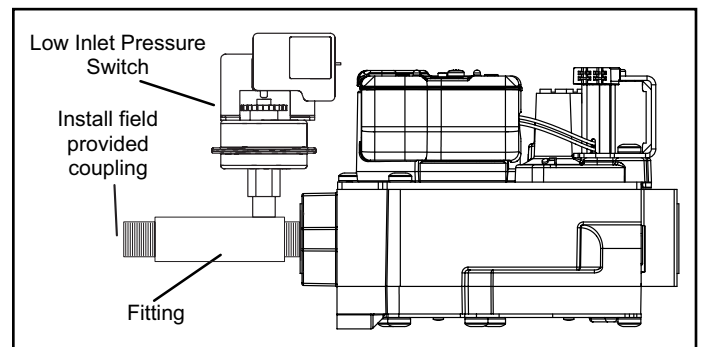

Figure 9. Thread Gas Supply (Resideo Gas Valve)

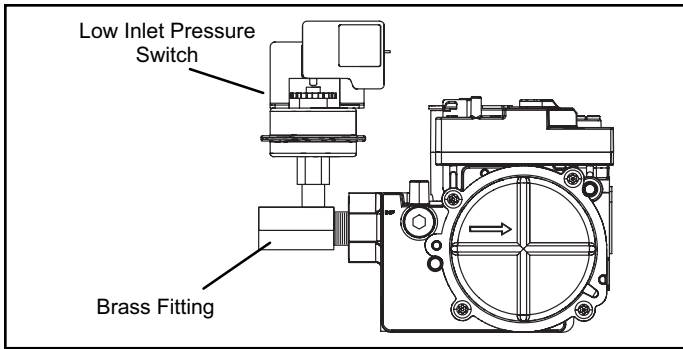

Figure 10. Gas Valve with Low Inlet Pressure Switch (White Rodgers Gas Valve)

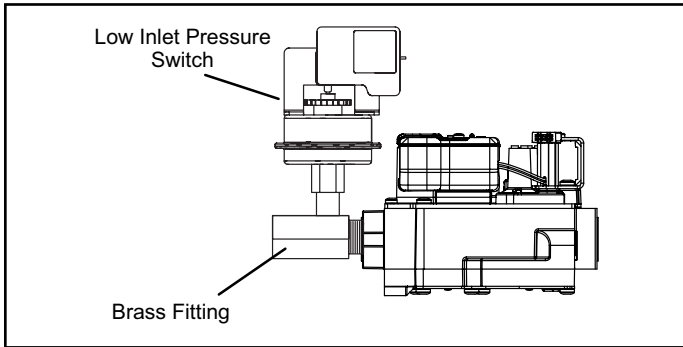

Figure 11. Gas Valve with Low Inlet Pressure Switch (Resideo Gas Valve)

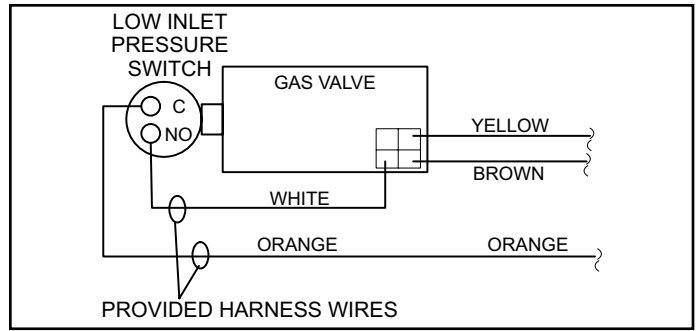

Figure 12. Low Inlet Pressure Switch Point-to-Point Wiring Diagram (White Rodgers Gas Valve)

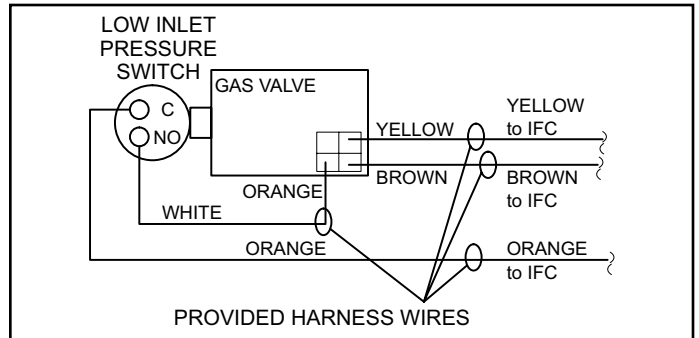

Figure 13. Low Inlet Pressure Switch Point-to-Point Wiring Diagram (Resideo Gas Valve)

10. Thread the gas supply to the fitting until hand tight. A field provided coupling may be needed. See Figure 8 or Figure 9. Using properly sized wrench to support fitting, tighten supply line into fitting 2 to 3 full turns to achieve leak free joint.

NOTE: Do not over tighten. (Maximum 3 full turns past hand tight for 1/2" NPT per ASME B1.20.1-2013)

11. Install pressure switch

For White Rodgers gas valves:

a. Thread pressure switch to fitting 2 to 3 turns past hand tight, then wire as shown in Figure 12.

For Resideo gas valves:

b. Connect the low inlet pressure switch in series between the adapter harness and the unit harness (IFC). Wire as shown in Figure 13.

- i. Connect yellow wire from gas valve adapter harness to yellow wire of unit harness (IFC).
- ii. Connect brown wire from gas valve adapter harness to brown wire of unit harness (IFC).
- iii. Connect orange wire from gas valve adapter harness to white wire of conversion kit harness.
- iv. Connect orange wire of conversion kit harness to orange wire of unit harness (IFC).

12. Restore the electrical power to the unit.

13. Inspect all sides of assembly. Turn on gas supply. Immediately check the entire fitting surface and assembly joints for gas leaks.

14. Affix nameplate conversion sticker next to unit nameplate.

15. Complete the information required on the gas converter sticker: date, name, and address. Affix sticker to the exterior of the unit in a visible area.

16. Follow the steps given in the start-up and adjustment section.

▲ IMPORTANT

Carefully check all piping connection for gas leaks. DO NOT use matches, candles, open flames or other means of ignition to check for gas leaks. Use a soap solution or other preferred means.

▲ CAUTION

Some soaps used for leak detection are corrosive to certain metals. Carefully rinse piping thoroughly after leak test has been completed. Do not use matches, candles, flame or other sources of ignition to check for gas leaks.

Start-Up & Adjustment

BEFORE PLACING THE UNIT INTO OPERATION

Smell all around the appliance area for gas. Be sure to smell next to the floor because LP/Propane gas is heavier than air and will settle on the floor.

Use only your hand to move the gas control switch. Never use tools. If the switch will not move by hand, do not try to repair it. Force or attempted repair may result in a fire or explosion.

A - Placing the Unit into Operation

▲ IMPORTANT

Follow the lighting instructions provided on the unit. If lighting instructions are not available, refer to the following section.

Units are equipped with a two-stage integrated ignition system. The integrated ignition control automatically lights the burners each time the thermostat calls for heat.

1. **STOP!** Read the safety information at the beginning of this section.
2. Set the thermostat to its lowest setting.
3. Turn off all electrical power to the furnace.
4. Do not try to light the burners by hand.
5. Remove the unit access panel.
6. Move the switch on the gas valve to OFF. Do not force the switch. See Figure 1 or Figure 2.
7. Wait five (5) minutes for any gas to clear out. If you then smell gas, STOP! Immediately call your gas supplier from a neighbor's phone. Follow the gas supplier's instructions. If you do not smell gas, go to the next step.
8. Move the switch on the gas valve to ON.
9. Replace the unit compartment access panel.
10. Turn on all electrical power to the unit.
11. Set the thermostat to desired setting.
12. If the furnace will not operate, see section E- "Turning Gas Off to the Unit" and call the gas supplier.

Gas Pressure Measurement

A - Supply Pressure Measurement

An inlet pressure post located on the gas valve provides access to the supply pressure. See Figure 1 or Figure 2. Back out the 3/32 hex screw one turn, connect a piece of 5/16 tubing and connect to a manometer to measure supply pressure. Check the unit on high fire. On multiple unit installations, check the unit separately and with the

other units operating. See Table 1 for supply line pressure. Following the supply pressure check, turn off unit, remove manometer and tighten post hex screw.

B - Measuring & Adjusting the Manifold Pressure

90% Two-Stage Models

A manifold pressure post located on the gas valve provides access to the manifold pressure. See Figure 1 or Figure 2. Back out the 3/32 hex screw one turn, connect a piece of 5/16 tubing and connect to a manometer to measure manifold pressure. To correctly measure manifold pressure, the differential pressure between the positive gas manifold and the negative burner box must be considered. Furnace should operate at least 5 minutes before checking manifold pressure.

1. Connect the test gauge positive side "+" to manifold pressure tap on gas valve as noted above.
2. Tee into the gas valve regulator vent hose and connect to test gauge negative "-".
3. Ignite unit on low fire and let run for 5 minutes to allow for steady state conditions.
4. After allowing unit to stabilize for 5 minutes, record low fire manifold pressure and compare to value given in Table 1. If necessary, make adjustment. Figure 1 shows location of low fire adjustment screw.
5. Repeat on high fire and compare to value given in Table 1. If necessary, make adjustment. Figure 1 and Figure 2 show location of high fire adjustment screw.

80% Two-Stage Models

A manifold pressure post located on the gas valve provides access to the manifold pressure. See Figure 1 or Figure 2. Back out the 3/32 hex screw one turn, connect a piece of 5/16 tubing and connect to a manometer to measure manifold pressure.

1. Connect test gauge to manifold pressure post (Figure 1) on gas valve.
2. Ignite unit on low fire and let run for 5 minutes to allow for steady state conditions.
3. After allowing unit to stabilize for 5 minutes, record manifold pressure and compare to value given in Table 1.
4. If necessary, make adjustments. Figure 1 and Figure 2 show location of high fire and low fire adjustment screws.
5. Repeat steps 2, 3 and 4 on high fire. See values in Table 1.

Manifold Pressure in w.g.		Gas Line Pressure in w.g.	
Low Fire	High Fire	Minimum	Maximum
4.5	10.0	11.0	13.0

Table 1. Manifold and Gas Line Pressure

C - Gas Flow (Approximate)

NOTE: To obtain accurate reading, shut off all other gas appliances connected to meter.

Furnace should operate at least 5 minutes before checking gas flow. Determine time in seconds for two revolutions of gas through the meter. (Two revolutions assures a more accurate time.) Divide by two and compare to time in Table 2. If manifold pressure matches Table 1 and rate is incorrect, check gas orifices for proper size and restriction. Remove temporary gas meter if installed.

Unit Capacity	Seconds for One Revolution	
	LP	
	1 cu ft Dial	2 cu ft Dial
-045	200	400
-070	136	272
-090	102	204
-110	82	164
-135	68	136
2500 btu/cu ft		

Table 2. Gas Meter Clocking Chart

D- Proper Combustion

Furnace should operate minimum 15 minutes with correct manifold pressure and gas flow rate before checking combustion. Take combustion sample beyond the flue outlet. See Table 3 through Table 5 .

NOTE: Shut unit off and remove manometer as soon as supply line pressure, manifold pressure and combustion sample have been obtained. Take care to replace pressure tap plug.

Unit Capacity	CO ₂ % for LP	
	Low Fire	High Fire
-045	6.4 - 7.4	8.8 - 9.8
-070	6.3 - 7.3	8.7 - 9.8
-090	6.8 - 7.8	8.9 - 9.9
-110	7.1 - 8.1	9.3 - 10.3
-135	7.1 - 8.2	9.1 - 10.1
The carbon monoxide reading should not exceed 100 ppm.		

Table 3. 90% Two-Stage Upflow / Horizontal Furnaces

Unit Capacity	CO ₂ % for LP	
	Low Fire	High Fire
-045	6.6 - 7.6	9.1 - 10.1
-070	6.5 - 7.5	8.6 - 9.6
-090	6.9 - 7.9	9.1 - 10.1
-110	7.3 - 8.3	9.5 - 10.5
The carbon monoxide reading should not exceed 100 ppm.		

Table 4. 90% Two-Stage Downflow Furnaces

All Models	Firing Rate	CO ₂ % for Nat	CO ₂ % for LP
Upflow/ Horizontal	High Fire	6.8 - 7.4	7.5 - 9.0
	Low Fire	4.2 - 5.7	5.0 - 6.0
Downflow	High Fire	6.0 - 7.4	6.9 - 8.4
	Low Fire	4.8 - 6.0	5.7 - 7.0
The carbon monoxide reading should not exceed 100 ppm.			

Table 5. 80% Two-Stage Furnaces

E - Turning Off Gas to the Unit

1. Set the thermostat to its lowest setting.
2. Turn off all the electrical power to the unit.
3. Remove the unit access panel.
4. Move the switch on the gas valve to OFF. Do not force the switch.