

PROPANE CONVERSION PARTS KIT# P-702

⚠ DANGER

Check the rating plate of the boiler / water heater to ensure it is configured for the fuel you are using.

Failure to perform the proper fuel conversion when required can result in an immediate hazard.

Operating any IBC boiler / water heater using a fuel other than the fuel listed on its rating plate is prohibited. If these instructions are not followed exactly, a dangerous situation can result, leading to fire, explosion or production of carbon monoxide, which may cause property damage, personal injury, or loss of life.

⚠ NOTE

These instructions are to be closely followed, and referenced to the details in the boiler / water heater's current certified Installation and Operating Instruction Manual.

The above listed modulating boilers / water heaters are factory fire-tested to operate with natural gas, or propane as ordered. The rating plate will be marked to indicate which fuel the particular boiler / water heater has been set up with. Firing a boiler / water heater with a fuel other than what is listed on the rating plate is prohibited unless the following conversion procedure is completed by a qualified technician.

The boiler / water heater will automatically de-rate the maximum input at a rate of approximately 2% per 1,000' above sea level. The gas valves zero governor will ensure that the gas:air mixture is not affected at altitude.

Important Note: If converting from Propane to Natural Gas - Order Propane to Natural Gas Conversion Kit, IBC Part# P-703 from your authorized IBC Distributor.

MODEL NUMBER	NATURAL GAS TO PROPANE	PROPANE TO NATURAL GAS
DC 33-124 / HC 33-124	P-702	P-703
DC 33-160 / HC 33-160	P-702	P-703

Table 1: Fuel Conversion Kits

WARNING

This conversion kit shall be installed by a qualified service agency in accordance with the manufacturer's instructions and all applicable codes and requirements of the authority having jurisdiction. If the information in these instructions is not followed exactly, a fire, an explosion or production of carbon monoxide may result causing property damage, personal injury or loss of life. The qualified service agency is responsible for the proper installation of this kit. The installation is not proper and complete until the operation of the converted appliance is checked as specified in the manufacturer's instructions supplied with the kit.

INCLUDED WITH CONVERSION KIT (IBC PART# P-702)

- 1 x Orifice, Marked 580 – IBC Part # 180-096
- 1 x Back Flow Insert, LP – IBC Part # 180-184
- 1 x O-Ring – IBC Part # 150-175
- 1 x Rating Plate Fuel Overlay - IBC Part # 80-142
- 1 x Gas Valve Conversion Label - IBC Part # 80-107B
- 1 x Installer Identifier Label - IBC Part # 80-150A
- 1 x Instruction Sheet - IBC Part # 120-189



PROPANE CONVERSION PARTS KIT# P-702

Refer to the details in the boiler / water heater’s current Installation and Operation Manual, section 3.3 - “COMMISSIONING”, 3.4 “FUEL CONVERSION”

⚠ CAUTION

The gas supply shall be shut off prior to disconnecting the electrical power, before proceeding with the conversion.

⚠ DANGER

A combustion test must be done by a qualified, trained and licensed gas fitter in order to complete any fuel conversion.

Making adjustments to the IBC gas valve without a properly calibrated gas combustion analyzer and by persons who are not trained and experienced in its use is forbidden. Failure to use an analyzer can result in an immediate hazard.

The Low Fire (Zero-offset) valve adjustment cap on the gas valve has been factory set. **This cap must not be tampered with. The Zero-offset screw is not to be adjusted in the field.** Consult factory if considering field adjustment of the Low Fire (zero offset) adjustment.

The High Fire (Gas:Air) ratio adjustment screw will have to be adjusted to attain optimum combustion results whenever fuel conversion is undertaken, however, **no mixture adjustment shall be performed unless done by a qualified technician using properly functioning and calibrated combustion analyzing equipment.** The following procedure must be carried out by a qualified technician:

CO ₂ VALUE (%) AT HIGH FIRE WITH THE FRONT COVER OPEN		
	NATURAL GAS	PROPANE
Max. CO ₂ value	10.1%	11.5%
Min. CO ₂ value	9.1%	9.8%
CO ₂ VALUE (%) AT LOW FIRE WITH THE FRONT COVER OPEN		
Max. CO ₂ value	= value at Max	= value at Max – 0.3%
Min. CO ₂ value	9.1%	9.5%

Table 2: CO₂ Values and High and Low Fire



Back Flow Insert

Fuel Conversion Instructions

The following procedure must be carried out by a qualified technician.

1. Ensure you are installing the correct fuel conversion kit for your boiler / water heater. Compare the boiler / water heater model number with the Kit# found in table #1. Ensure you have the correct Orifice by checking the Orifice number with the Chart on page 3.
2. Ensure the fuel conversion instructions supplied with the fuel conversion kit are read, understood and followed carefully.
3. The gas supply shall be shut off prior to disconnecting the electrical power, and before proceeding with the conversion. Ensure that the gas supply is turned off at the gas shut off valve.
4. Disconnect the nut at the gas valve outlet and remove the O-ring and Orifice. Disconnect the 2 electrical connections on the fan. Remove the 2 nuts at the fan outlet connecting the fan to the heat exchanger and carefully remove the fan from the boiler. Remove the Back Flow Insert installed up into the heat exchanger.

Units produced before June 2018 only (date code xxxxx-1806k-xxxx (2018/ June) or earlier): Remove the translucent Back Flow Flapper from the Back Flow Insert. Attach the new black Back Flow Flapper onto the Back Flow Insert. Store the translucent Back Flow Flapper inside the boiler cabinet for future use.

Reinstall the Back Flow Insert into the heat exchanger (ensure that the red silicone rubber is facing away from the heat exchanger, see picture in Side Bar). Re-install the fan with the fan gasket and tighten the 2 nuts at the fan outlet.

5. Insert the correct orifice into the O-ring and re-install into the nut at the gas valve outlet (top of the gas valve) and tighten the nut.
6. Restore gas supply by opening the gas control valve, and using an approved leak detection solution, soap test all joints.
7. Carefully follow the procedures on page 3, Combustion Testing and Adjustment
8. Place the conversion labels associated with the new fuel onto the boiler / water heater at the positions indicated page 4 of this Instruction Document.

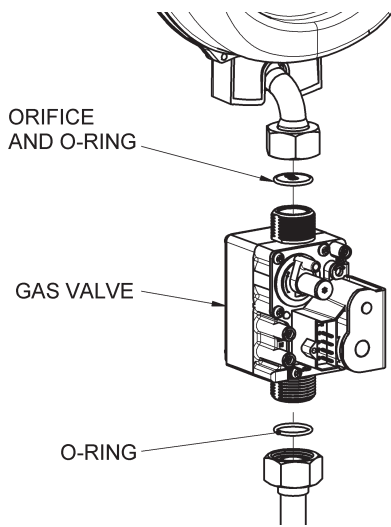

Gas Valve Assembly

PROPANE CONVERSION PARTS KIT# P-702

MODEL NUMBER	HIGH FIRE INPUT
NATURAL GAS OR PROPANE	
DC/HC 33-124	124 MBH
DC/HC 33-160	160 MBH

Table 3: Rated input of a converted boiler / water heater

Clocking the Meter (Natural Gas)

1. Turn off all other appliances and pilots
2. Turn on the boiler / water heater and set the boiler / water heater to high fire. Ensure the boiler / water heater has a large load to heat so that the boiler / water heater will not shut off.
3. With a Stop-Watch, record the number of seconds for the smallest dial to make 1 full revolution.
4. $CFH = (3600 \times \text{Dial Size}) / \text{Seconds}$
5. $CFH \times 1000$ (check local Btu content) = Input Btu's

NOTE:

- For 2 PSI meters multiply CFH x 1.097
- For Metric meters multiply CFH x 35.3
- For 2 PSI metric meters multiply CFH x 1.097 x 35.3
- For Altitude deduct 2% per 1,000' of altitude from the Input Btu's

PROPANE ORIFICE CHART	
MODEL NUMBER	ORIFICE SIZE
DC/HC 33-124	580
DC/HC 33-160	580

Combustion Testing and Adjustment

To verify the proper operation of the gas valve in the field, the following procedure can be carried out by a qualified technician (*diagrams on this page*).

Normal ignition system sequence of operation: The boiler / water heater control, upon a call for heat or DHW, will turn on the combustion fan for a 5 second pre-purge, then energize the spark electrode and gas valve for a 5 second trial for ignition. If the burner does not light and prove flame, the process is repeated until the burner lights and flame is detected or after 4 trials for ignition the boiler / water heater will lock out and will need to be manually reset by pressing the Reset button

1. Turn off the boiler / water heater's gas shut off valve. With a small (1/8" or 3 mm) flat screwdriver, open the inlet gas supply pressure test port by turning its center-screw 1 full turn counterclockwise. Attach a manometer to the pressure test port and turn on gas to appliance. Static manometer reading should be ideally 7" w.c., for Natural Gas and 11" w.c. for Propane. Minimum and maximum static pressure should be between 7" and 14" w.c. Monitor pressure throughout the commissioning procedure. Pressure may drop up to 1" to 2" w.c. at high fire. Outlet Pressure (Manifold Pressure) should be between -0.04" w.c. and 0.00" w.c. with a target of -0.02" w.c. **NOTE:** The outlet pressure should only be measured with an accurate digital manometer. Consult factory before considering field adjustment.
2. Allow the boiler / water heater to ignite / run against a large load, to maintain high fire. Enter the High Fire Manual Mode by pressing both the Service and Plus buttons together twice. "H" will be showing in the service display. **NOTE:** Do not make any adjustments if an "h" is showing in the service display. Allow the boiler / water heater to operate at High Fire for 3 minutes to stabilize.
3. With a combustion analyzer probe in the flue gas test port, turn the High Fire (Gas : Air Ratio Adjustment) screw (*see diagrams on this page*) to achieve results. This screw offers very fine adjustment, and may require several turns. **NOTE:** Clock the gas meter to confirm full maximum rating plate input. Check the measured results with Table 3 - High Fire.
4. Switch the boiler / water heater to low fire by pressing both the Service button and Minus buttons at the same time. The boiler / water heater will drop to low fire. Compare the readings with Table 11 - Low Fire.
5. Switch off the boiler / water heater by pressing the On/Off button. Turn off the gas at the boiler / water heater's gas shut off valve. Remove the flue gas analyzer from the test port and reinstall the test port cap. Remove the gas pressure manometer from the gas valve and close the test port. Turn on the gas at the boiler / water heater's gas shut off valve. Ensure there are no gas leaks and reinstall the front cover. Turn on the boiler / water heater by pressing the On/Off button.

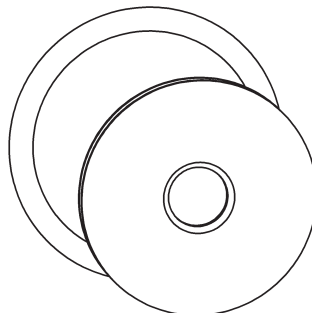

Orifice and O-ring

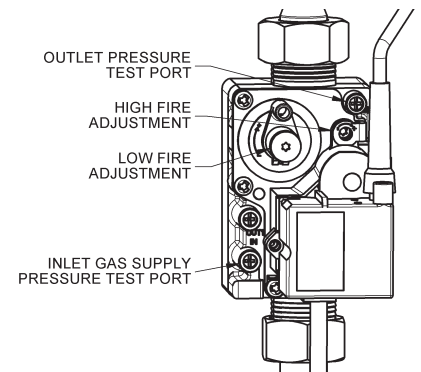

Gas Valve Adjust

PROPANE CONVERSION PARTS KIT# P-702

NOTE

The Installer must fill in the information and affix the included fuel conversion labels to the boiler / water heater in the positions indicated after the conversion is completed

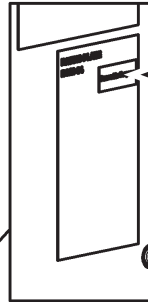
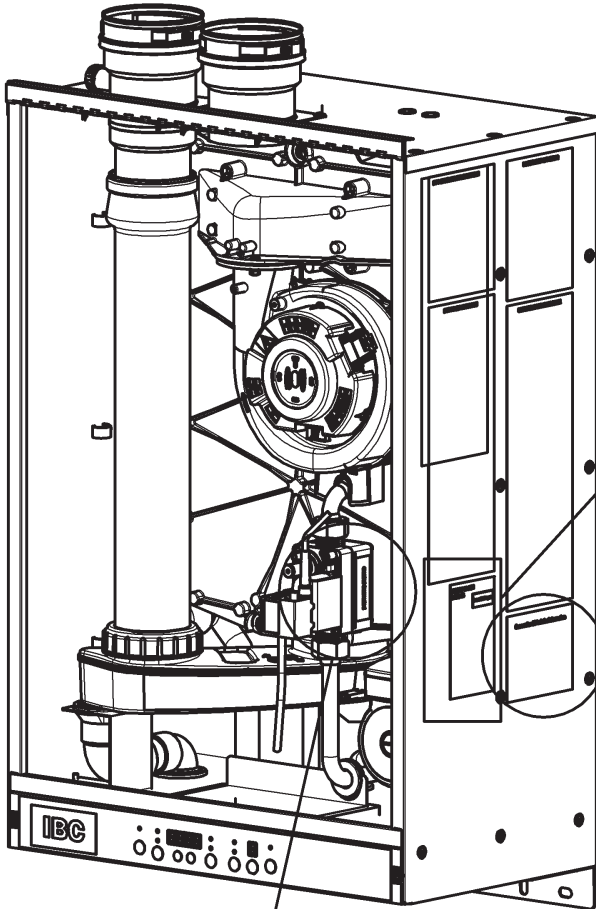

Rating Plate Overlay for DC / HC 33-124 & DC / HC 33-160

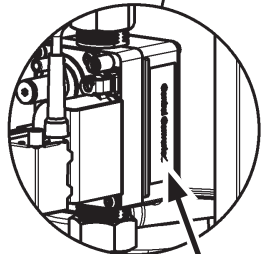
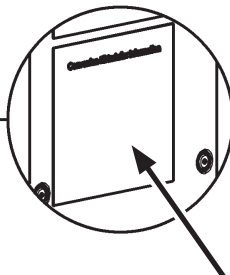

This control has been converted for use with:
 Cette commande a été convertie pour fonctionner au gaz:

Natural Gas Gaz naturel
 Propane Propane

80-107B R1

Gas Valve Conversion Label

<p>IBC Better Boilers</p> <p>THIS BOILER / WATER HEATER HAS BEEN CONVERTED FROM NATURAL GAS TO PROPANE CETTE CHAUDIÈRE / CHAUFFE-EAU A ÉTÉ CONVERTI À PARTIR DU GAZ NATUREL AU PROPANE</p>	
<p>DC / HC SERIES BOILER / WATER HEATER DC / HC SERIE CHAUDIÈRE / CHAUFFE-EAU</p>	
This boiler / water heater was converted on day/month/year Cette chaudière / chauffe-eau a été convertie le année/mois/jour	Fuel / Carburant Propane
Kit No. _____ Trousse No. _____	Inlet Pressure / Pression d'entrée 14" W.C. / po C.E. max. 5" W.C. / po C.E. min.
Installation Company _____ Entreprise d'installation _____ Address/Adresse _____	Manifold Pressure / Pression du collecteur - 0.02" W.C. / po C.E. (Low fire, door off / Faible feu, porte hors)
Input / Entrée Unchanged / Inchangé	
Installer accepts the responsibility that this conversion has been properly made. Installer accepte l'entière responsabilité de la qualité de la conversion.	
Upon completion of the fuel conversion, affix this completed label to the right side of the boiler, beside the rating plate. À la fin de la conversion de carburant, apposer cette étiquette complétée sur le côté droit de la chaudière, à côté de la plaque signalétique.	
80-150A	

Label 80-150A to be filled in by installer